

# Air 8

---

User Guide V1.0



VOID

©2018 Void Acoustics Research Ltd.

Version 1.0

This user guide is subject to change without notice.  
For the latest online version, visit: [www.voidacoustics.com](http://www.voidacoustics.com)

Void Acoustics and the Void logo are registered trademarks of Void Acoustics Research Ltd. in the United Kingdom, USA and other countries; all other Void trademarks are the property of Void Acoustics Research Ltd.

# Contents

---

<b>1</b>	<b>Safety and regulations</b>	<b>4</b>
1.1	Important safety instructions	4
1.2	Limitations	4
1.3	EC declaration of conformity	4
1.4	WEEE directive	4
<b>2</b>	<b>Limited warranty</b>	<b>5</b>
<b>3</b>	<b>Unpacking and Checking</b>	<b>6</b>
<b>4</b>	<b>About</b>	<b>7</b>
4.1	Welcome	7
4.2	Air 8 overview	7
4.3	Key features	7
4.4	Air 8 specifications	8
4.5	Air 8 dimensions	9
<b>5</b>	<b>Cabling and wiring</b>	<b>10</b>
5.1	Electrical safety	10
5.2	Cable consideration for fixed installations	10
5.3	Air 8 wiring diagram	10
5.4	Bias V3/V9 speakON™ wiring	11
5.5	Bias VQ speakON™ wiring	11
5.6	Bias D1/Q2 Phoenix wiring	12
5.7	Bias Q5 speakON™ wiring	12
<b>6</b>	<b>System design</b>	<b>13</b>
6.1	System design principles	13
6.2	Loudspeaker placement and positioning	14
<b>7</b>	<b>Mounting</b>	<b>17</b>
7.1	Installation safety	17
7.2	Bracket mounting	18
<b>8</b>	<b>Service</b>	<b>20</b>
8.1	Return authorisation	20
8.2	Shipping and packing considerations	20
<b>9</b>	<b>Appendix</b>	<b>21</b>

# 1 Safety and regulations

## 1.1 Important safety instructions



The lightning flash with an arrowhead symbol within an equilateral triangle is intended to alert the user to the presence of uninsulated "dangerous voltage" within the product's enclosure that may be of sufficient magnitude to constitute a risk of electric shock to persons.



The exclamation point within an equilateral triangle is intended to alert the user of the presence of important operating and maintenance (servicing) instructions in the literature accompanying the appliance.

### Safety instructions - read this first

1. Read these instructions.
2. Keep these instructions.
3. Heed all warnings.
4. Follow all instructions.
5. Do not use this apparatus near water.
6. Clean only with a dry cloth.
7. Do not block any ventilation openings. Install in accordance with the manufacturer's instructions.
8. Do not install near any heat source such as radiators, heat registers, stoves, or other such apparatus that produce heat.
9. Do not defeat the safety purpose of the grounding-type plug. A grounding type plug has two blades and a third grounding prong. The third prong is provided for your safety. If the provided plug does not fit into your outlet, consult an electrician for replacement of the obsolete outlet.
10. Protect power cords from being walked on or pinched particularly at plugs, convenience receptacles, and the point where they exit the apparatus.
11. Only use attachments and accessories specified by Void Acoustics.
12. Only use with the cart, stand, tripod, bracket, or table specified by the manufacturer, or sold with the apparatus. When a cart is used, use caution when moving the cart/apparatus combination to avoid injury from tip-over.
13. Unplug the apparatus during lightning storms or when unused for long periods of time.
14. Refer all servicing to qualified service personnel. Servicing is required when the apparatus has been damaged in any way, such as when the power-supply cord or plug is damaged, liquid has been spilled or objects have fallen into the apparatus, the apparatus has been exposed to rain or moisture, does not operate normally, or has been dropped.
15. Since the mains power supply cord attachment plug is used to disconnect the device, the plug should always be easily accessible.
16. Void loudspeakers can produce sound levels capable of causing permanent hearing damage from prolonged exposure. The higher the sound level, the less exposure needed to cause such damage. Avoid prolonged exposure to the high sound levels from the loudspeaker.

## 1.2 Limitations

This guide is provided to help familiarise the user with the loudspeaker system and its accessories. It is not intended to provide comprehensive electrical, fire, mechanical and noise training and is not a substitute for industry-approved training. Nor does this guide absolve the user of their obligation to comply with all relevant safety legislation and codes of practice.

While every care has been taken in creating this guide, safety is user-dependent and Void Acoustics Research Ltd cannot guarantee complete safety whenever the system is rigged and operated.

## 1.3 EC declaration of conformity

### Manufacturer:

Void Acoustics Research Ltd,  
Unit 15 Dawkins Road Ind Est,  
Poole, Dorset,  
BH15 4JY,  
United Kingdom.



We declare the under our sole responsibility the following product models: Air Motion, Tri Motion, Airten, Air Stream, Air Vantage, Air 8

are intended to be used as loudspeakers and are in conformity with the following EC Directives, including all amendments, and with national legislation implementing these directives:

- BS EN 60065:2002
- BS EN 55103-1/-2

March 2016

Alex Skan  
Technical Director

## 1.4 WEEE directive

If the time arises to throw away your product, please recycle all the components possible.



This symbol indicates that when the end-user wishes to discard this product, it must be sent to separate collection facilities for recovery and recycling. By separating this product from other household-type waste, the volume of waste sent to incinerators or land-fills will be reduced and natural resources will thus be conserved.

The Waste Electrical and Electronic Equipment Directive (WEEE Directive) aims to minimise the impact of electrical and electronic goods on the environment. Void Acoustics Research Ltd complies with the Directive 2002/96/EC and 2003/108/EC of the European Parliament on waste electrical and electronic equipment (WEEE) in order to reduce the amount of WEEE that is being disposed of in land-fill sites. All of our products are marked with the WEEE symbol; this indicates that this product must NOT be disposed of with other waste. Instead it is the user's responsibility to dispose of their waste electrical and electronic equipment by handing it over to an approved reprocessor, or by returning it to Void Acoustics Research Ltd for reprocessing. For more information about where you can send your waste equipment for recycling, please contact Void Acoustics Research Ltd or one of your local distributors.

## 2 Limited warranty

---

### Limited warranty

#### The warranty

For a period of three (3) years from the date of delivery to the original purchaser (as shown on the original invoice or sales receipt; a copy of this may be required as proof of warranty dates), Void Acoustics Research Ltd (hereinafter "Void") warrants to the Original Owner (person or company who originally purchased the product brand new from either Void or a Void Authorised Dealer/Distributor) of each new Air Series product (provided it was purchased at an Authorised Void Dealer) that it is free of defects in materials and workmanship and that each product will meet or exceed all factory published specifications for each respective model. Void agrees to repair or replace (at its discretion) all defective parts at no charge for labour or materials; subject to following provisions:

#### Warranty violations

Void shall take no responsibility for repair or replacement as specified under this warranty, if the damaged product has been subject to misuse, accident, neglect or failure to comply with normal maintenance procedures; or if the serial number has been defaced, altered or removed. Nor will Void accept responsibility for, or resulting from, improper alterations or unauthorised parts or repairs. This warranty does not cover any damage to speakers or any other consequential damage resulting from breach of any written or implied warranty.

#### Void warranty provisions

Void will remedy any defect, regardless of the reason for failure (except as excluded) by repair, or replacement. Void will remedy the defect and ship the product within a reasonable time after receipt of the defective product at a Void Authorised Service Centre.

#### To obtain warranty service

If a Void product requires service, the Owner must contact Void or an Authorised Void Service Centre to receive an R.A.N. (Return Authorisation Number) and instructions on how to return the product to the Void Authorised Service Centre, or to Void.

Void (or its Authorised Service Centre) will initiate corrective repairs upon receipt of the returned product. Please save the original carton and all the packing materials in case shipping is required. All products being returned to the factory or service centre for repairs must be shipped prepaid.

If the repairs made by Void or the Void Authorised Service Centre are not satisfactory, the Owner is instructed to give written notice to Void. If the defect or malfunction remains after a reasonable number of attempts by Void to remedy the defect or malfunction, the Original Owner shall then have the option to elect either a refund or replacement of said Void product free of charge. The refund shall be an amount equal to but not greater than the actual purchase price, not including any taxes, interest, insurance, closing costs and other finance charges (minus reasonable depreciation on the product). If a refund is necessary, the Original Owner must make the defective or malfunctioning product available to Void free and clear of all liens or other restrictions.

#### Equipment modifications

Technical and design specifications are subject to change without notice.

Void reserves the right to modify or change equipment (in whole or part) at any time prior to delivery thereof, in order to include therein electrical or mechanical improvements deemed appropriate by Void, but without incurring any liability to modify or change any equipment previously delivered, or to supply new equipment in accordance with any earlier specifications.

#### Disclaimer of consequential and incidental damages

You, the Original Owner, are not entitled to recover from Void any incidental damages resulting from any defect in the Void product.

This includes any damage to another product or products resulting from such a defect.

#### Warranty alterations

No person has the authority to enlarge, amend, or modify this Warranty. This Warranty is not extended by the length of time which the Original Owner is deprived of the use of product. Repairs and replacement parts provided pursuant to the Warranty shall carry only the non-expired portion of the Warranty.

**This Statement of Warranty supersedes all others contained in this user guide.**

## 3 Unpacking and checking

---

All Void Acoustics products are carefully manufactured and thoroughly tested before being despatched. Your dealer will ensure that your Void products are in pristine condition before being forwarded to you but mistakes and accidents can happen.

Before signing for your delivery:

- Inspect your shipment for any signs of contamination, abuse or transit damage as soon as you receive it
- Check your Void Acoustics delivery fully against your order
- If your shipment is incomplete or any of its contents are found to be damaged; inform the shipping company and inform your dealer.

When you are removing your Air 8 loudspeaker from its original packaging:

- Air 8 loudspeakers come double boxed and are stapled shut; take care when unboxing and removing the staples to avoid injury or damage to the loudspeaker
- If you need to place the Air 8 loudspeaker on a flat surface ensure you use a lint free product to protect the finish
- When you have removed the Air 8 loudspeaker from the packaging inspect it to ensure there is no damage and keep all original packaging in case it needs to be returned for any reason.

See section 2 for warranty conditions and see section 8 if your product needs servicing.

# 4 About

---

## 4.1 Welcome

Many thanks for purchasing this Void Acoustics Air 8. We truly appreciate your support. At Void, we design, manufacture and distribute advanced professional audio systems for the installed and live sound market sectors. Like all Void products, our highly skilled and experienced engineers have successfully combined pioneering technologies with ground-breaking design aesthetics, to bring you superior sound quality and visual innovation. In buying this product, you are now part of the Void family and we hope using it brings you years of satisfaction. This guide will help you both use this product safely and ensure it performs to its full capability

## 4.1 Air 8 overview

The Air 8 is an interior designer's dream come true and a sound purist's heaven. Highly refined in-house designed components, combined in a modern work of art. This installation-friendly package provides impressive efficiency for its compact, stylish form.

## 4.3 Key features

- Passive 8" two-way surface mount loudspeaker
- Linear frequency and phase characteristics
- High-power internal crossover for ease of setup
- Low resonance fibreglass composite construction
- Supplied Air 8 wall bracket
- Optimised dispersion provides greater direct to reflected sound
- Phoenix Connector with Link Out

# 4 About

## 4.4 Air 8 specifications

Configuration	1 x 8" : 1 x 1" Coax
Frequency response	70 Hz - 20 kHz $\pm 3$ dB
Maximum output <sup>1</sup>	119 dB cont, 121 dB peak
Sensitivity <sup>2</sup>	95 dB 1W/1m
Impedance	8 $\Omega$
Power handling <sup>3</sup>	300 W AES
Dispersion	90°H x 90°V
Crossover point	2 kHz passive
Connectors	Phoenix
Construction	Fibreglass
Mounting	Air 8 wall bracket (supplied)
Height	420 mm (16.5")
Width	299 mm (11.8")
Depth	171 mm (6.7")
Weight	6.2 kg (13.7 lbs)
Colour	Custom colours available upon request

<sup>1</sup> Calculated <sup>2</sup> Measured in half space <sup>3</sup> AES2 - 1984 compliant

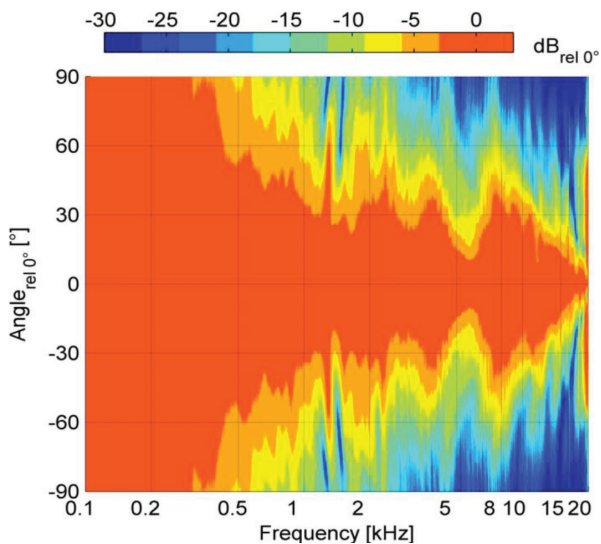

Figure 4.1: Horizontal directivity isobars

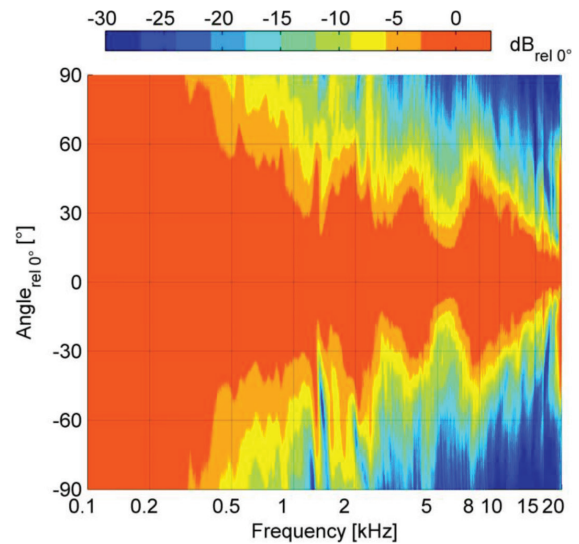

Figure 4.2: Vertical directivity isobars



# 4 About

## 4.5 Air 8 dimensions

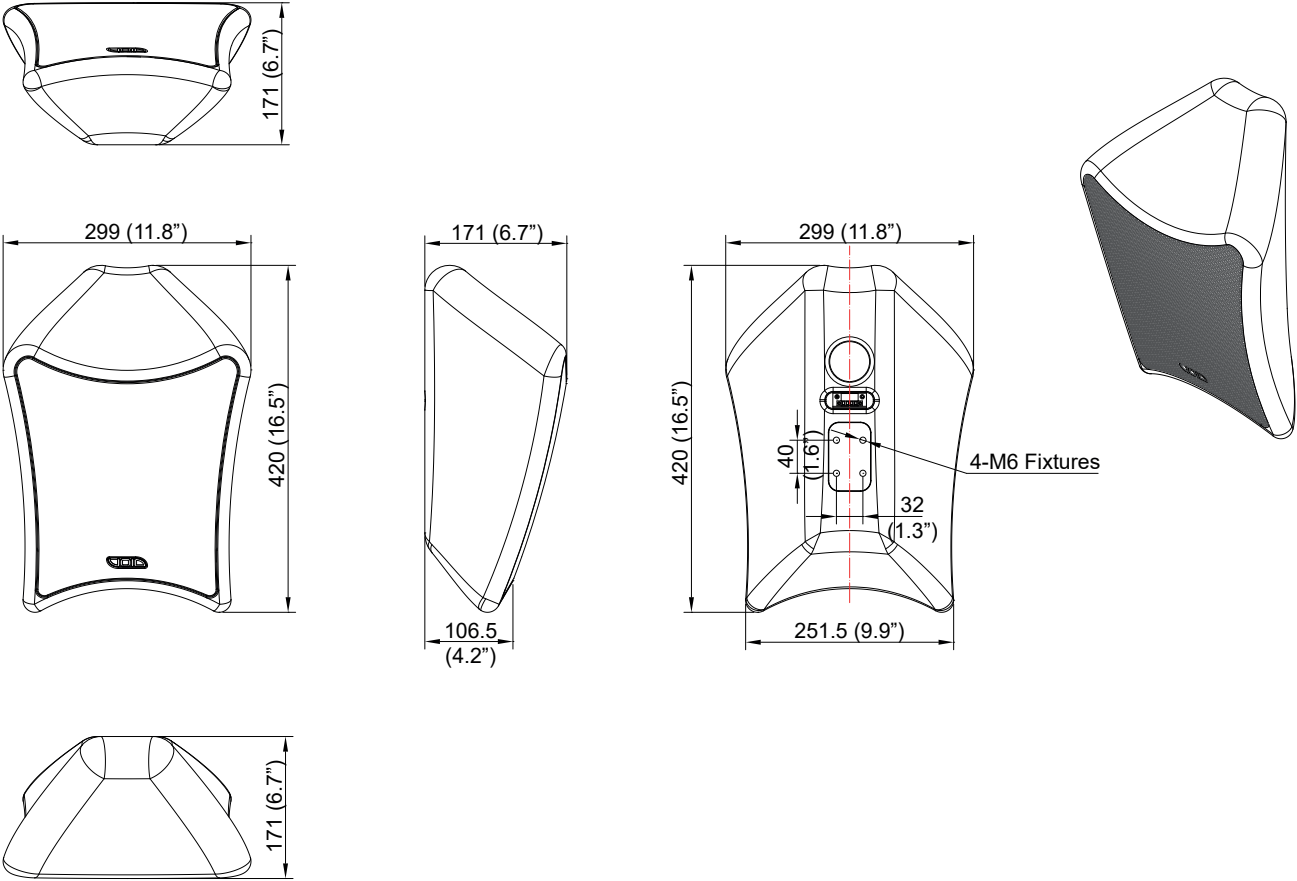

Figure 4.3: Dimensions

# 5 Cabling and wiring

## 5.1 Electrical safety



To avoid electrical hazards please note the following:

- Do not access the inside of any electrical equipment. Refer servicing to Void-approved service agents.

## 5.2 Cable considerations for fixed installations

We recommend specifying installation-grade Low Smoke Zero Halogen (LSZH) cables for permanent installations. The cables should use Oxygen Free Copper (OFC) of grade C11000 or above. Cables for permanent installations should be compliant with the following standards:

- IEC 60332.1 Fire retardancy of a single cable
- IEC 60332.3C Fire retardancy of bunched cables
- IEC 60754.1 Amount of Halogen Gas Emissions
- IEC 60754.2 Degree of acidity of released gases
- IEC 61034.2 Measurement of smoke density.

We suggest using the following maximum copper cable lengths to keep level losses below 0.6 dB.

Metric mm <sup>2</sup>	Imperial AWG	8 Ω load	4 Ω load	2 Ω load
2.50 mm <sup>2</sup>	13 AWG	36 m	18 m	9 m
4.00 mm <sup>2</sup>	11 AWG	60 m	30 m	15 m

## 5.3 Air 8 wiring diagram

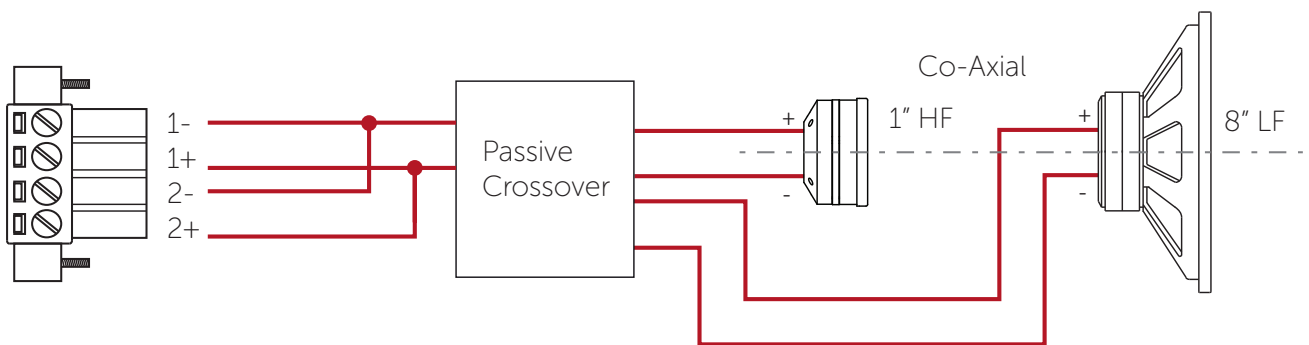

Figure 5.1: Wiring diagram

	Phoenix pins 1+/1-	Phoenix pins 2+/2-
In	12" LF	Link/out

# 5 Cabling and wiring

## 5.4 Bias V3/V9 speakON™ wiring

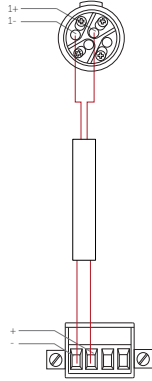
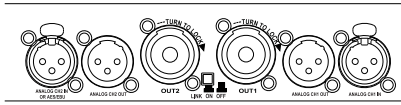

Figure 5.2: Bias V3

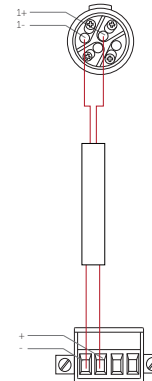
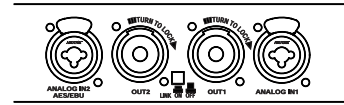

Figure 5.3: Bias V9

Bias V3/V9	Out 1
Output	LF (8") and HF (1")
Max parallel units	4 (2 Ω load to amplifier)

## 5.5 Bias VQ speakON™ wiring

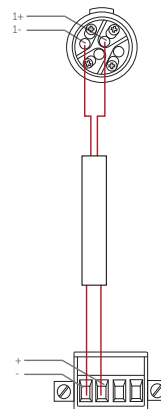
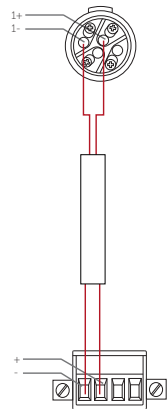
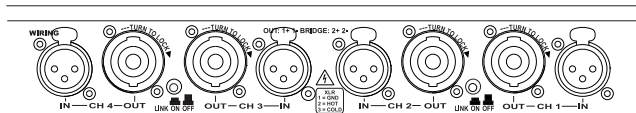

Figure 5.4: Bias VQ

Bias VQ	Out 1	Out 3
Output	LF (8") and HF (1")	LF (8") and HF (1")
Max quantity per channel	2 (4 Ω load to amplifier)	2 (4 Ω load to amplifier)

# 5 Cabling and wiring

## 5.6 Bias D1/Q2 Phoenix wiring

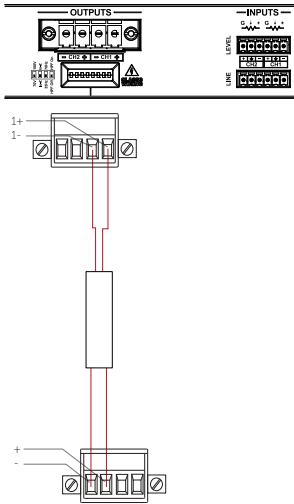

Figure 5.5: Bias D1

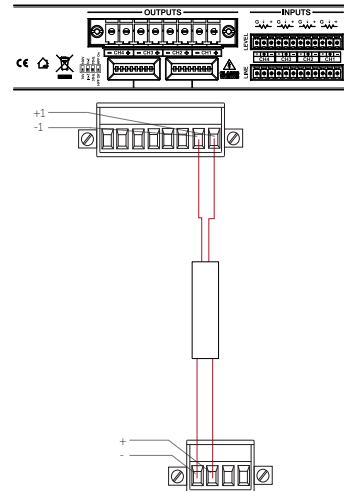

Figure 5.6: Bias Q2

Bias D1/Q2	Out 1
Output	LF (8") and HF (1")
Max parallel units	4 (2 $\Omega$ load to amplifier)

## 5.7 Bias Q5 speakON™ wiring

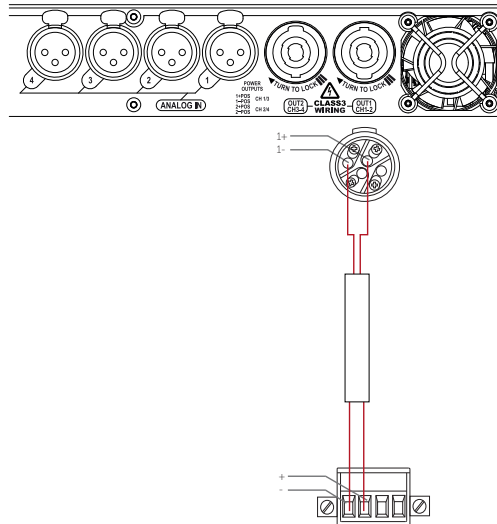

Figure 5.7: Bias Q5

Bias Q5	Out 1
Output	LF (8") and HF (1")
Max quantity per channel	4 (2 $\Omega$ load to amplifier)

# 6 System design

---

## 6.1 System design principles

Air 8 loudspeakers can be arrayed as a single pair facing forward to provide a wide stereo image.



Figure 6.1: Air 8 loudspeakers single pair arrangement

For applications requiring wide horizontal coverage, use two Air 8 loudspeakers in pairs, angled at about 40°.

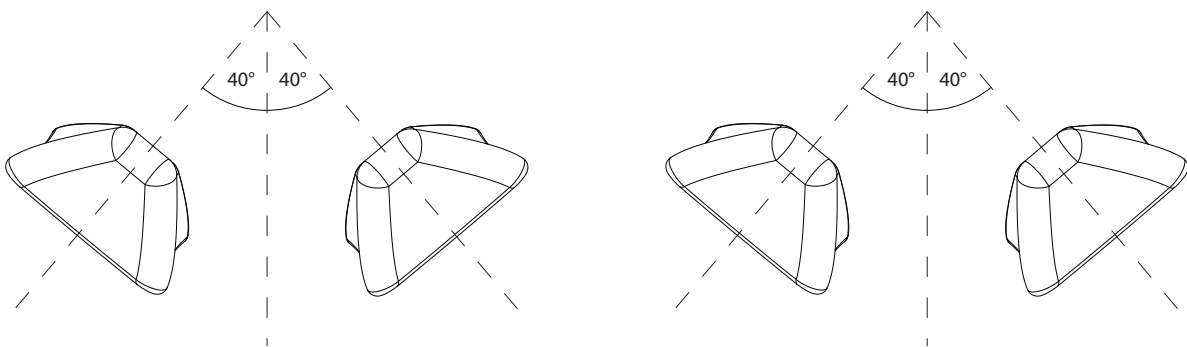

Figure 6.2: Air 8 loudspeaker dual pair arrangement

For permanent installation, it is recommended to fly Air 8 loudspeakers for more even coverage. This also allows co-located low frequency enclosures in a single block, increasing sensitivity and providing more consistent bass coverage.



Figure 6.3: Air 8 permanent installation

# 6 System design

## 6.2 Loudspeaker placement and positioning

When deploying Air 8 loudspeakers, it is important to consider the speakers' vertical position to maximise coverage in the vertical axis. Horizontal loudspeaker dispersion figures dictate the coverage of the loudspeaker, left to right, to the -3 dB points. The same can be said for the vertical dispersion figure, but when applied to a listening area, this figure dictates the audience area coverage front to back.

Vertical dispersion is often overlooked or not assessed properly, resulting in inefficiently deployed loudspeaker systems that require more fill loudspeakers than are necessary to achieve required coverage. Following are some basic guidelines when considering the vertical position of your Air 8 loudspeaker.

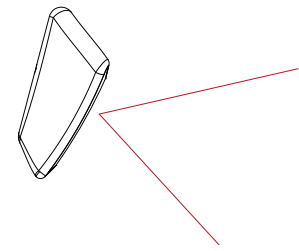

Figure 6.4a: Vertical dispersion (side view)

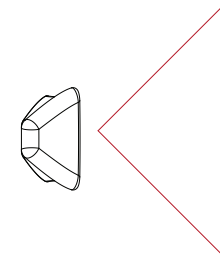

Figure 6.4b: Horizontal dispersion (top view)

With optimum vertical positioning and aiming applied the loudspeaker system can be used at maximum efficiency. With a point source loudspeaker in this configuration the speaker is placed 2m-4m from the ground, aimed half way to two thirds of the way back from the audience area, as shown in figure 6.5. The applied aiming reduces unwanted reflections from the ceiling and directs the highest energy concentration to the audience area requiring it most. This is the most desirable position for the loudspeakers in this example.

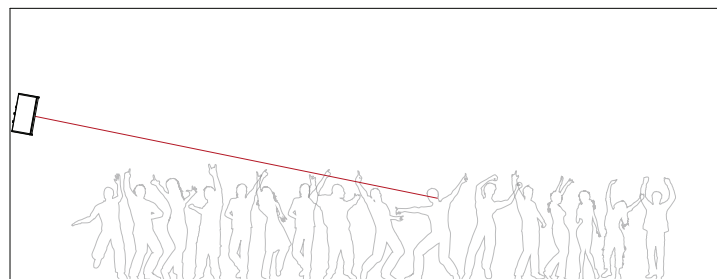

Figure 6.5: Correct loudspeaker placement



# 6 System design

---

A multi-point loudspeaker system in a club/bar environment can be very pleasing for the listener. However, it's important that the processes applied to previous examples are still implemented. In figure 6.6 you can see the loudspeakers have been positioned and aimed optimally. When deploying a multi-point loudspeaker system, extra consideration must be taken to counter unwanted room effects. Careful positioning and aiming of loudspeakers will minimise room effects, while maintaining even coverage throughout the audience area.

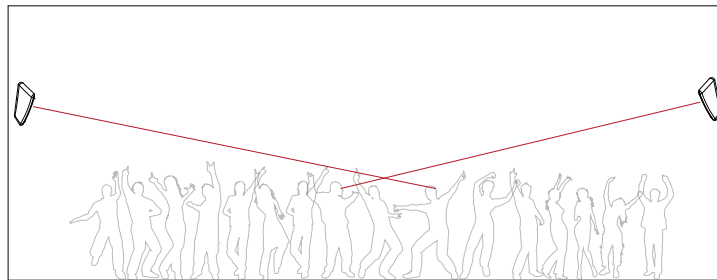

Figure 6.6: Multi point loudspeaker arrangement

In the horizontal plane rotate the Air 8 loudspeakers toward the audience area at an angle such that the centre line of the dispersion from each loudspeaker meets about two thirds of the way towards the rear of the audience area. This will help provide a wider coverage and result in more of the power being used usefully.

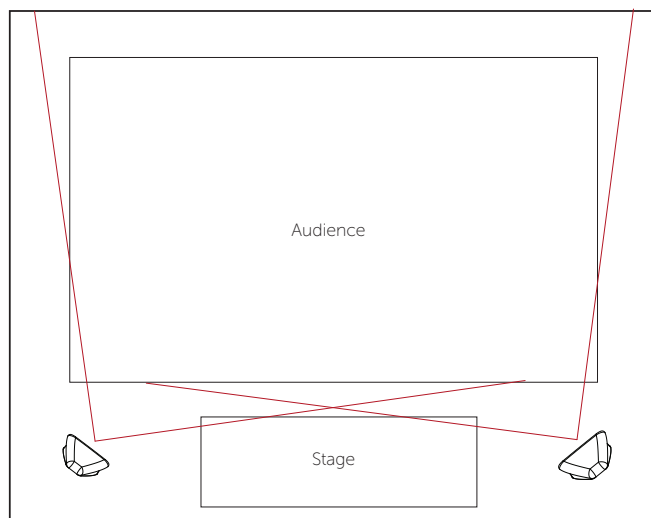

Figure 6.7: Correct horizontal dispersion

## 6 System design

---

Avoid directing the Air 8 loudspeaker straight forward. This will result in a proportion of the power being directed towards the walls, creating possible reflective issues, as well as causing a gap in coverage at the centre of the audience area.

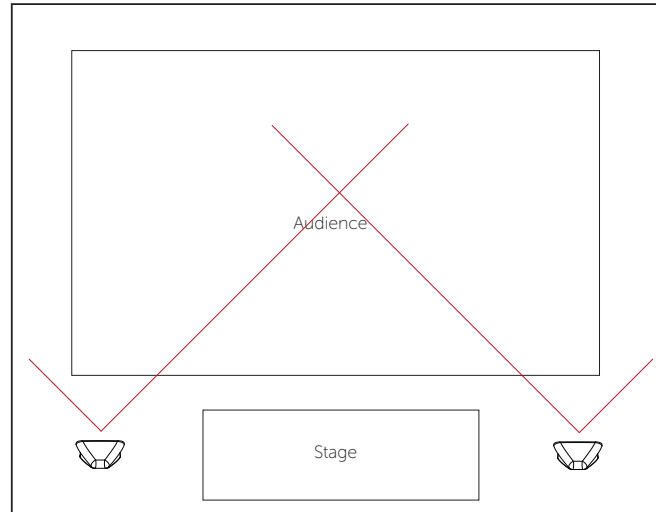

Figure 6.8: Incorrect horizontal dispersion

In figure 6.9 the loudspeakers vertical positioning is too low for the audience area. Mid and high range frequencies are absorbed by the first two rows of people, resulting in poor coverage and potential acoustic issues from room reflections.

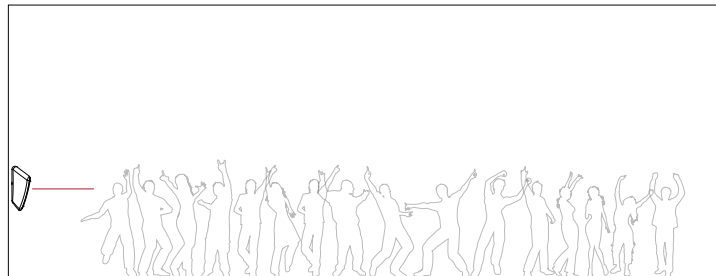

Figure 6.9: Incorrect loudspeaker placement

Figure 6.10 shows the loudspeaker vertical position is optimal for the audience area but the user hasn't applied an aiming angle. In this case, a large portion of energy is directed at the ceiling that could result in reduced intelligibility and unwanted room acoustic characteristics. The shallow angle of attack will also induce refraction issues on a hot dance floor, leading to reduced HF penetration at mid and far distances, again reducing intelligibility and coherence.

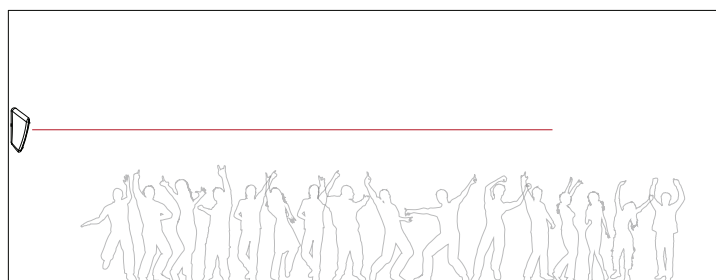

Figure 6.10: Incorrect loudspeaker placement



# 7 Mounting

---

## Tools required

- 4 mm Allen key

### 7.1 Installation safety



To avoid mechanical hazards, please note the following:

- Safety regulations vary in different regions. Full compliance with those regulations must be your priority
- Rigging must only be undertaken by fully-qualified and experienced riggers who understand local regulations
- This may include consulting a structural engineer before installation of wall brackets
- Remember that all personnel have a duty of care to themselves, to their assistants, to the venue staff and to the public
- Before lifting any part of the system above head height, check the whole rig for loose tools or other items that may fall and cause injury
- Do not use a telephone (even if hands-free) while rigging. Always concentrate fully on the rigging operation
- Do not rig equipment that is worn, damaged, corroded, mishandled or over-stressed in any way
- Use only Void-approved mounting equipment and accessories

## 7.2 Bracket mounting

---

Parts required:

- Air 8 bracket (supplied)
- 4 mm Allen key

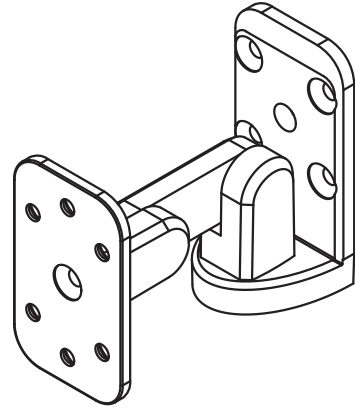

Figure 7.1: Air 8 bracket

Step 1:  
Remove all four M6 bolts from the rear of the loudspeaker.

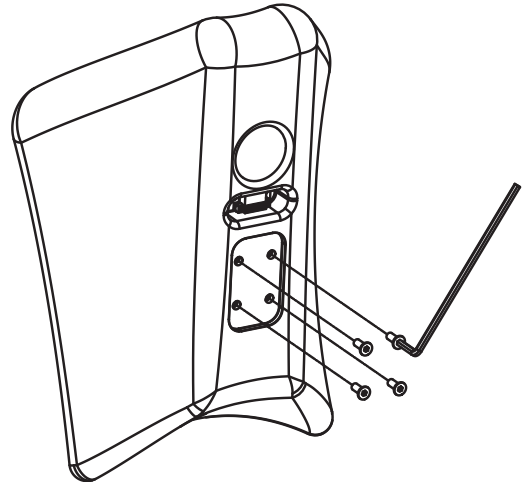

Figure 7.2: Bolt removal

Step 2:  
Lift the loudspeaker into position and attach all four M6 bolts.



All four bolts must be fitted when securing the bracket to the wall. Take care when mounting the bracket to the wall, making sure to use the correct fixing and that the wall can take the load, for example do not attach the bracket to a stud wall.

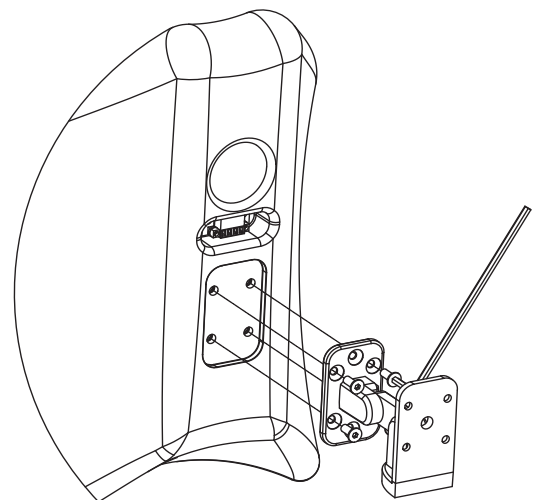

Figure 7.3: Fixing bracket

## 7.2 Bracket mounting

---

Step 3:  
With the lifting gear in place adjust the angle of the bracket using the bolt on the bracket assembly.

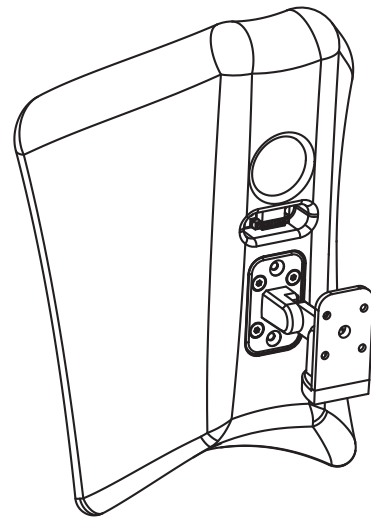

Figure 7.16: Loudspeaker positioning

# 8 Service

---

Void Air 8 loudspeakers should only be serviced by a fully-trained technician.



No user serviceable parts inside. Refer servicing to your dealer.

## 8.1 Return authorisation

Before returning your faulty product for repair, please remember to get an R.A.N. (Return Authorisation Number) from the Void dealer who supplied the system to you. Your dealer will handle the necessary paperwork and repair. Failure to go through this return authorisation procedure could delay the repair of your product.

Note that your dealer will need to see a copy of your sales receipt as proof of purchase so please have this to hand when applying for return authorisation.

## 8.2 Shipping and packing considerations

- When sending a Void Air 8 loudspeaker to an authorised service centre, please write a detailed description of the fault and list any other equipment used in conjunction with the faulty product.
- Accessories will not be required. Do not send the instruction manual, cables or any other hardware unless your dealer asks you to.
- Pack your unit in the original factory packaging if possible. Include a note of the fault description with the product. Do not send it separately.
- Ensure safe transportation of your unit to the authorised service centre.

# 9 Appendix

---

## Architectural specifications

The loudspeaker shall be a passive two-way system consisting of one high power 8" (203.2 mm) direct radiating reflex loaded low frequency (LF) transducer and a 1" (25 mm) diameter co-axially-mounted neodymium high frequency (HF) compression transducer mounted in a fibreglass, smooth cellulose enclosure.

The low frequency transducer shall be constructed on a cast aluminium frame, with a treated paper cone, 50.8 mm (2") voice coil, wound with copper wires on a high quality voice coil former, for high power handling and long-term reliability. The high frequency transducer shall be bolted through the rear of the magnet structure belonging to the LF transducer to form a co-axial drive unit. The sound will project through a machined waveguide that exits in the centre of the low frequency transducer to use the 203.2 mm (8") baffle diameter to achieve pattern control and low distortion.

Performance specifications for typical production unit shall be as follows: the usable on-axis bandwidth shall be 70 Hz to 20 kHz ( $\pm 3$  dB) and shall average 90° directivity pattern for both horizontal and vertical axis (-6 dB down from on-axis level) from 1 kHz to 10 kHz; maximum SPL of 119 dB continuous, 121 dB peak measured at 1 m using IEC268-5 pink noise. Power handling shall be 300 W AES at a rated impedance of 8  $\Omega$ ; crossover point at 2 kHz using a 4th order filter (24 dB per octave).

The wiring connection shall be via a single, removable, lockable wiring connector with four screw-down terminals (one pair for input and one pair for loop-out to another loudspeaker) to provide secure wiring and to allow for pre-wiring of the connector before the installation. This connector should then screw lock to the enclosure to ensure secure attachment.

The enclosure shall be of a moulded fibreglass reinforced plastic construction with a smooth cellulose finish and shall include integral threaded inserts for the fitment of wall and ceiling mounting hardware of any RAL colour with external dimensions of (H) 420 mm x (W) 299 mm x (D) 171 mm (16.5" x 11.8" x 6.7"). Weight shall be 6.2 kg (13.7 lbs).

The loudspeaker shall be the Void Acoustics Air 8.





## North America

---

Void Acoustics North America  
503-854-7134  
sales.usa@voidacoustics.com

## Head Office

---

Void Acoustics Research Ltd  
Unit 15 Dawkins Road Industrial Estate  
Poole  
Dorset  
BH15 4JY  
England

+44 (0) 1202 666 006  
info@voidacoustics.com

Registered in England & Wales No. 07533536

[www.voidacoustics.com](http://www.voidacoustics.com)

