



Lake[®] PROCESSING CARD **MY8-LAKE**

Owner's Manual
Bedienungsanleitung
Mode d'emploi
Manual de instrucciones
Manuale di istruzioni
Руководство пользователя
使用说明书
取扱説明書

EN

DE

FR

ES

IT

RU

ZH

JA

English

Deutsch

Français

Español

Italiano

Русский

中文

日本語

FCC INFORMATION (U.S.A.)

1. IMPORTANT NOTICE: DO NOT MODIFY THIS UNIT!

This product, when installed as indicated in the instructions contained in this manual, meets FCC requirements. Modifications not expressly approved by Yamaha may void your authority, granted by the FCC, to use the product.

2. IMPORTANT:

When connecting this product to accessories and/or another product use only high quality shielded cables. Cable/s supplied with this product MUST be used. Follow all installation instructions. Failure to follow instructions could void your FCC authorization to use this product in the USA.

3. NOTE:

This product has been tested and found to comply with the requirements listed in FCC Regulations, Part 15 for Class "B" digital devices. Compliance with these requirements provides a reasonable level of assurance that your use of this product in a residential environment will not result in harmful interference with other electronic devices. This equipment generates/uses radio frequencies and, if not installed and used according to the instructions found in the users manual, may cause interference harmful to the operation of other electronic devices. Compliance

with FCC regulations does not guarantee that interference will not occur in all installations. If this product is found to be the source of interference, which can be determined by turning the unit "OFF" and "ON", please try to eliminate the problem by using one of the following measures:

Relocate either this product or the device that is being affected by the interference.

Utilize power outlets that are on different branch (circuit breaker or fuse) circuits or install AC line filter/s.

In the case of radio or TV interference, relocate/reorient the antenna. If the antenna lead-in is 300 ohm ribbon lead, change the lead-in to co-axial type cable.

If these corrective measures do not produce satisfactory results, please contact the local retailer authorized to distribute this type of product. If you can not locate the appropriate retailer, please contact Yamaha Corporation of America, Electronic Service Division, 6600 Orangethorpe Ave, Buena Park, CA90620

The above statements apply ONLY to those products distributed by Yamaha Corporation of America or its subsidiaries.

* This applies only to products distributed by YAMAHA CORPORATION OF AMERICA.

(class B)

COMPLIANCE INFORMATION STATEMENT (DECLARATION OF CONFORMITY PROCEDURE)

Responsible Party : Yamaha Corporation of America

Address : 6600 Orangethorpe Ave., Buena Park, Calif. 90620

Telephone : 714-522-9011

Type of Equipment : LAKE PROCESSING CARD

Model Name : MY8-LAKE

This device complies with Part 15 of the FCC Rules.

Operation is subject to the following two conditions:

- 1) this device may not cause harmful interference, and
 - 2) this device must accept any interference received including interference that may cause undesired operation.
- See user manual instructions if interference to radio reception is suspected.

* This applies only to products distributed by YAMAHA CORPORATION OF AMERICA.

(FCC DoC)

This device complies with Part 15 of the FCC Rules. Operation is subject to the following two conditions:

- (1) this device may not cause harmful interference, and
- (2) this device must accept any interference received, including interference that may cause undesired operation.

CANADA

This Class B digital apparatus complies with Canadian ICES-003.

Cet appareil numérique de la classe B est conforme à la norme NMB-003 du Canada.

* This applies only to products distributed by Yamaha Canada Music Ltd.

* Ceci ne s'applique qu'aux produits distribués par Yamaha Canada Musique Ltée.

(class B)

이 기기는 가정용(B급) 전자파적합기기로서 주로 가정에서 사용하는 것을 목적으로 하며, 모든 지역에서 사용할 수 있습니다.

(class b korea)

Contents

PRECAUTIONS.....	4
Introduction	5
Welcome	5
Features	5
Installation	5
Included Accessories	5
USB Flash Drive Contents.....	6
Part Names and Functions	7
Configuration and Module	8
Mesa Configuration Signal Flow (System EQ)	8
Contour Configuration Signal Flow (Crossover).....	9
Contour/Mesa Configuration Signal Flow.....	10
Frames and Modules	10
System Examples	11
System EQ (Mesa)	11
Crossover (Contour).....	11
Quick Start Guide	12
Installation and Cable Connection.....	12
Lake Controller Software Installation.....	12
Console (Host Device) Settings	12
Starting the Lake Controller	13
Placing Modules	13
I/O Configuration.....	14
Levels Screen	16
PEQ & GEQ Overlays.....	18
HPF/LPF Screen (Mesa mode only).....	19
Storing Modules and Systems	20
Changing the MY8-LAKE Frame Configuration	21
XOVER Screen (Contour mode only)	22
Contour Levels Screen.....	22
Appendix	24
Problems and Warnings.....	24
Troubleshooting	25
Specifications.....	30

PRECAUTIONS

PLEASE READ CAREFULLY BEFORE PROCEEDING

*** Please keep this manual in a safe place for future reference.**



WARNING

Always follow the basic precautions listed below to avoid the possibility of serious injury or even death from electrical shock, short-circuiting, damages, fire or other hazards. These precautions include, but are not limited to, the following:

- Do not install the card in any Yamaha products not specified by Yamaha for use with the card to avoid possible electrical shock, fire, or equipment damage.
- Do not attempt to disassemble or modify the card. Do not apply excessive force to card connectors or other card components. Mishandling of the card may lead to shock, fire hazard, or equipment failure.
- Be sure to disconnect the power cable of the host device before installing the card and connecting/disconnecting the cables (in order to eliminate shock hazard, undesired noise, and avoid equipment damage).
- Turn off all peripheral devices connected to the host device before installation, and unplug all related cables (in order to eliminate shock hazard, undesired noise, and avoid equipment damage).



CAUTION

Always follow the basic precautions listed below to avoid the possibility of physical injury to you or others, or damage to the device or other property. These precautions include, but are not limited to, the following:

- Be sure to properly ground the host device to prevent electrical shock and/or malfunction.
- Do not touch the metallic leads (pins) of the circuit board when handling the card. The pins are sharp and may cause hand cuts.
- Wear a pair of heavy gloves during installation to avoid scratching or cutting your hands on sharp edges.

- Avoid touching exposed connectors and metal parts to minimize the possibility of bad connections.
- Drain all static electricity from your clothing and body before handling the card. Static electricity can damage the card. Touch an exposed metal part of the host device or other grounded object beforehand.
- Do not drop the card or subject it to physical shock as this can result in breakage and/or malfunction.
- Do not drop screws or other small parts inside the card. If power is applied while screws or similar metal objects are loose inside the unit the card may malfunction or be damaged. If you cannot retrieve dropped objects yourself, refer the problem to qualified Yamaha service personnel.

Yamaha cannot be held responsible for damage caused by improper use or modifications to the device, or data that is lost or destroyed.

- The illustrations as shown in this manual are for instructional purposes only, and may be different from the ones on your equipment.
- Lake is a registered trademark of Lab.gruppen AB.
- Windows is a registered trademark of Microsoft® Corporation in the United States and other countries.
- The company names and product names in this manual are the trademarks or registered trademarks of their respective companies.

European models

Purchaser/User Information specified in EN55103-1 and EN55103-2.

Conforms to Environments: E1, E2, E3 and E4

Introduction

Welcome

Thank you for choosing the Yamaha MY8-LAKE Lake[®] Processing card. The MY8-LAKE is a DSP expansion Mini-YGDAI card for use with compatible Yamaha professional audio devices. The card allows audio processing via insert to the host device or AES/EBU connection, enabling you to take advantage of the built-in advanced Lake[®] Processing technology for system equalization (EQ) and loudspeaker crossover processing. Lake Processing technology contains digital audio signal processing including EQ, levels, delay, limiters and crossovers along with advanced control capabilities via the Lake Controller software.

To take advantage of the powerful features and to ensure years of trouble-free use, please read this manual in conjunction with the Lake Controller Operation Manual (included in the Lake Controller software), before using the card.

Features

- Configurable as an 8 x 8 system EQ (Mesa mode) or as a 4 x 12 crossover (Contour mode) or as a hybrid configuration (Contour/Mesa) featuring 4 x 4 system EQ and 2 x 6 crossover.
- Input EQ in both Mesa and Contour modes features Lake Mesa EQ™ (asymmetric filtering) and Ideal Graphic EQ™ with Raised Cosine Equalization technology for accurate and faster EQ control.
- Classic and linear phase crossovers are available when configured in Contour mode.

- Supports up to twelve audio processing output channels (dependent on configuration) featuring independent gain and delay along with RMS and peak limiters featuring Lake LimiterMax™ technology.
- Eight internal host inputs/outputs and eight AES inputs/outputs.
- Network connectivity allows Lake Controller software on Windows PC to control and monitor the processing as well as other Lake devices.

Installation

Refer to the owner's manual supplied with the host device for installation details. The screws on the left and right sides of the card also ground (earth) the device, so be sure to tighten them securely.

NOTICE

Before installing the card in a host device, verify that the device is compatible with the card, and that the maximum number of Yamaha and third-party expansion cards simultaneously installed is not exceeded. Refer to the owner's manual supplied with the audio device, and/or the Yamaha Pro Audio web site at:

<http://www.yamahaproaudio.com/>

Included Accessories

- **MY8-LAKE Owner's manual** (this document)

This manual illustrates how to install the card, make the settings of a host device, and set up the Lake Controller software. For details about the Lake Controller software, refer to the Lake Controller Operation Manual.

- **USB Flash Drive** (see contents on next page)

USB Flash Drive Contents

- **Lake Controller Software Installer**

This software installer provides the Lake Controller software (for Windows), which is necessary for use of the MY8-LAKE card, along with the associated documentation and firmware update utilities.

Documentation is available from the Windows Start Menu after software is installed.

For the latest information about the system requirements, refer to the Lake website: <http://www.lakeprocessing.com>

- **Lake Controller Operation Manual (English only)**

This PDF document is included as part of the Lake Controller software installer, and provides detailed information on the Lake Controller software used to control the audio processing and routing.

- **Lake Network Configuration Guide (English only)**

This PDF document is included as part of the Lake Controller software installer, and provides detailed network configuration information, such as IP address settings and connection of multiple PCs.

- **MY8-LAKE Owner's Manual**

A color PDF version of this manual is included in the USB flash drive. Read this owner's manual thoroughly to help you understand how to install and use the software and hardware associated with the MY8-LAKE card.

- **Release Notes**

This PDF document is included in the Lake Controller software installer, and contains the latest release notes and important supplementary information.

NOTE

- To verify that the included USB flash drive contains the latest version of the Lake Controller software, and to locate supporting documentation, refer to the Lake website: <http://www.lakeprocessing.com>
- To view PDF files, you will need to install Adobe Reader on your computer. You can download the latest Adobe Reader at the following website: <http://www.adobe.com>

Part Names and Functions

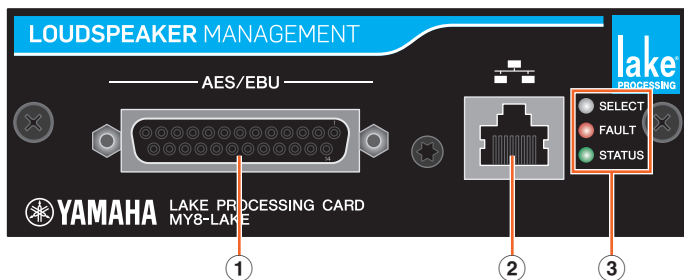

① AES/EBU connector

This is a D-sub 25-pin connector that inputs and outputs eight digital audio signals in AES/EBU format.

Supported sampling frequencies are 44.1, 48, 88.2, and 96 kHz.

② NETWORK connector

This is a RJ-45 connector (100 Mbps) that connects to a PC (Lake Controller).

③ LED indicators

- **SELECT:** The white LED is lit (static) to confirm device selection from within the Lake Controller software; it flashes when the Lake Controller is communicating with the device, and is off when neither selection nor communication is occurring.
- **FAULT:** The red LED is either lit (static) or flashes to warn that a serious problem is occurring. A fault can include an internal error, a slipping digital clock, module output clipping, or a problem on the card interface.
For additional information about LED indications and their meaning, refer to the section "Problems and Warnings" in the chapter "Appendix."
- **STATUS:** The green LED flashes to indicate that the MY8-LAKE card is correctly booted and operational; it is lit (static) when the digital input clock is locked.

Configuration and Module

Mesa Configuration Signal Flow (System EQ)

The MY8-LAKE defaults to an 8x8 system EQ configuration referred to as Mesa mode. This configuration provides eight discrete channels of audio processing as shown in the diagram below.

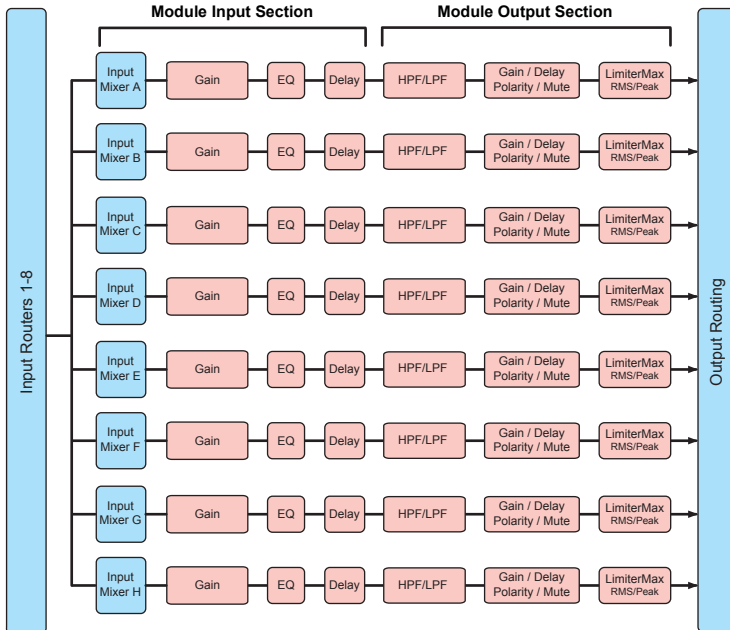

NOTE

- Each module is equipped with an Input Mixer, which allows the input signals to be mixed together.
- The Output Router provides the ability to directly route any input sources and Input Router outputs as well as module outputs to any output destinations.

Contour Configuration Signal Flow (Crossover)

In Contour mode (crossover), the MY8-LAKE provides 4x12 crossover modules as shown in the diagram below.

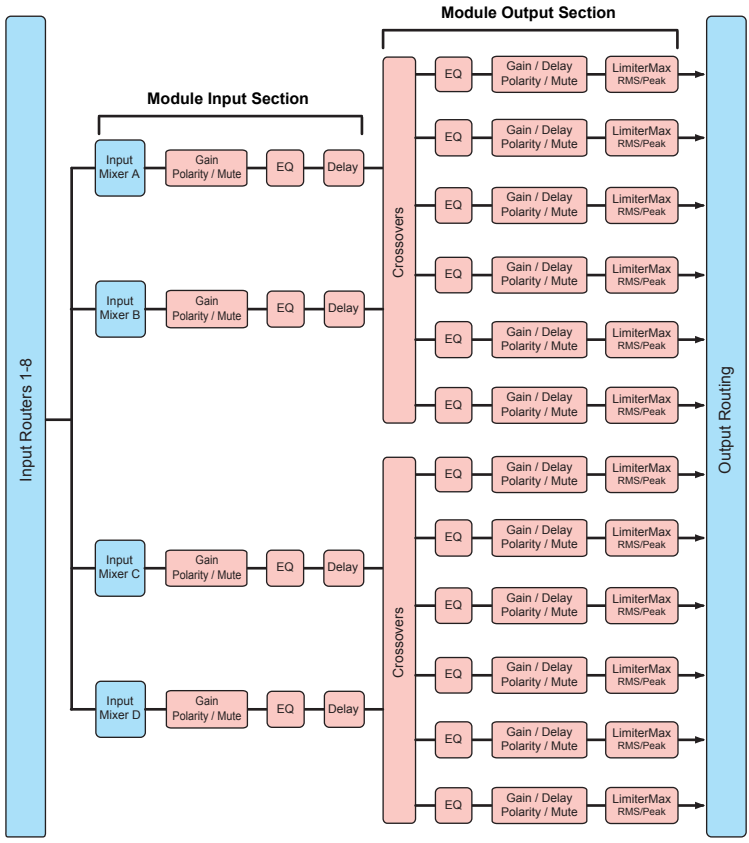

Contour/Mesa Configuration Signal Flow

In hybrid mode (Contour/Mesa), the MY8-LAKE provides 2x6 crossover modules and 4x4 system EQ modules as shown in the diagram below.

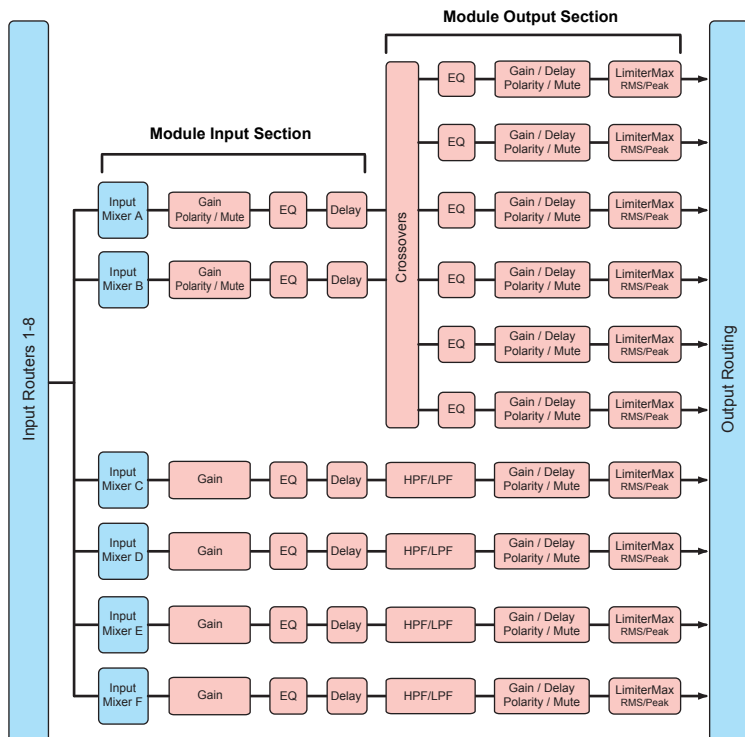

Frames and Modules

The term "Frame" is used to represent a physical Lake device (e.g., the MY8-LAKE card). The MY8-LAKE frame can contain two to eight audio processing units referred to as "Modules."

In Mesa mode (default) the MY8-LAKE Frame contains eight modules, labeled as modules A – H. Each Mesa module provides a single channel of EQ, levels and dynamics processing and only uses the module type of "Mesa EQ."

In Contour mode the MY8-LAKE Frame contains up to four modules labeled A – D; in Contour/Mesa mode there are up to six modules labeled A – F. The number of modules available in a Contour or Contour/Mesa mode is dependent on the Contour module types in use.

Contour modules can be configured in many different ways, such as 2-, 3-, 4-, 5-, and 6-way Classic Crossovers (Bessel, Butterworth, Linkwitz-Riley), 2-, 3-, and 4-way Linear Phase Crossovers, or as full bandwidth Auxiliary Outputs. For a Contour module example, refer to the section "XOVER Screen" later in the Quick Start Guide.

System Examples

The MY8-LAKE card can be used in a variety of ways; this chapter describes two typical scenarios.

System EQ (Mesa)

System EQ can be applied in Mesa mode; this is the default configuration for the MY8-LAKE card. Mesa mode provides eight channels of discrete audio processing that can be assigned to the host channel Insert Ins from the Insert Outs, without the use of any physical cabling—thanks to the card solution. This configuration provides powerful Lake EQ and dynamics processing for use as system EQ (in front-of-house mixes, for example), or as individual input channel EQ (in vocal processing, for example). If three cards are installed, this powerful, versatile EQ can be used in up to 24 mixes, which supports any scale of monitor system equalization. The Mesa modules can also be used for subsystem aligning and tuning, replacing the host console's Matrix section with an Input Mixer of each module.

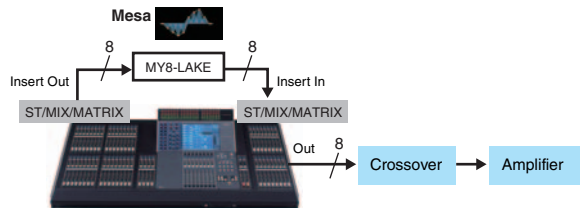

Crossover (Contour)

Crossover can be applied in the Contour mode for Lake. The MY8-LAKE provides a 4x12 crossover configuration; the processed channel signals can be routed internally back to the host device (up to 8 channels), and/or output via the AES/EBU D-sub 25-pin connector (up to 8 channels). In this system example, the stereo main mix signals from the host are routed to the MY8-LAKE for crossover, EQ, levels and dynamics processing. The processed signals are sent back to the available channels on the host and/or the AES/EBU connector, then to the power amplifiers or powered speakers.

The output signals contain only the relevant frequencies (post-crossover) for each amplifier and speaker. This scenario removes the need for separate outboard crossover and EQ processing, reducing the amount of external hardware and racks required to achieve the same result as traditional active speaker crossover systems.

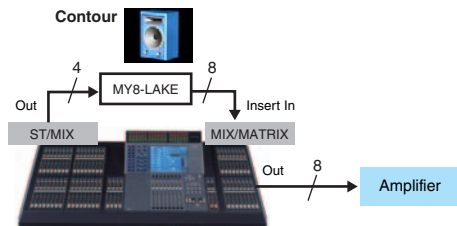

Quick Start Guide

Installation and Cable Connection

The first thing you should do is to install the card in your host device. For detailed installation instructions, refer to the owner's manual supplied with your host device.

- 1. Install the MY8-LAKE into an appropriate slot on your host device while the power is turned off, and tighten the two screws of the card to ensure a secure connection.**
- 2. Connect a Cat5/Cat6 Ethernet cable between the MY8-LAKE and the Windows PC that will be used for the Lake Controller.**

NOTE

- When using multiple PCs, Lake devices, or wireless access points, a network switch is required.
- The default IP Address Config on the MY8-LAKE is Auto - Zero Conf (169.254.x.x); if connectivity problems are encountered, try setting the network adapter of the PC to the same subnet range or to another fixed IP address such as 192.168.0.x.
- If Dante audio networking coexists on the same network for the other Lake devices, additional network configuration will be required.
- For further details about configuring the Lake Controller network, refer to the Lake Controller Operation Manual and Lake Network Configuration Guide.
- To prevent electromagnetic interference, use an STP (shielded twisted pair) Ethernet cable.

Lake Controller Software Installation

To enable full functionality and operation of the MY8-LAKE, the Lake Controller software must be installed in your Windows PC.

- 1. Insert the included USB flash drive into your Windows PC.**
- 2. Follow the on-screen prompts to install the software.**

We recommend that you check online for the most recent version of the Lake Controller.

Console (Host Device) Settings

Before using the MY8-LAKE, the I/O patchings on the console (host device) must be executed according to the specific mode, as described in the following examples.

CAUTION

Make sure to mute or move the faders all the way down when making the console settings to avoid undesired sound.

Mesa mode: For typical applications for system EQ or input EQ, you will normally insert the Lake Processing into insert points of any input or output channels on the console. On the INSERT screen of the console, patch the corresponding channels of the SLOT for the MY8-LAKE card to the Insert Outs and Ins of the desired channels on the console, and make sure the INSERT buttons are ON.

Contour mode: For typical applications for crossover processing, the output ports of the desired ST L/R or MIX channels should be patched to the corresponding channels of the SLOT for the MY8-LAKE

card. The post-crossover signals can be routed back to the host or out to the AES/ EBU connector. In case of routing back to the host, patch the corresponding channels of the SLOT to the Insert In of any empty output channels. If any input channels are available instead, you can also patch to the input ports and directly output the signals via Direct Out.

NOTE

For details about the console settings, refer to the owner's manual supplied with your host device.

Starting the Lake Controller

To start the Lake Controller with an online MY8-LAKE card connected for the first time, follow the steps below.

1. **Double-tap (click) the Lake Controller icon on the Windows desktop.**
2. **If the Select Network Adapter dialog appears, select the relevant network adapter for the MY8-LAKE connection from the list and tap [Select Adapter].**

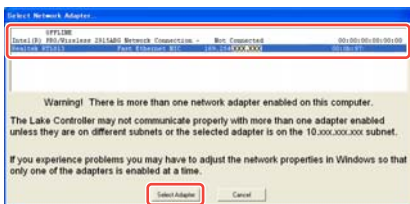

3. **Tap [No] if prompted to recall the last system configuration.**

NOTE

- After a proper network configuration and a valid Network connection are established, your MY8-LAKE card is now online and can be controlled using the Lake Controller software.
- Ensure that the Lake Controller is allowed full access through the Windows firewall.

Placing Modules

The default configuration for the MY8-LAKE is eight Mesa EQ modules, providing a total of eight discrete module inputs and outputs. For instructions on changing the configuration, refer to “Changing the MY8-LAKE Frame Configuration” on page 21.

1. **Tap the [Modules] button from the main Home screen to call up the module scroll bar.**

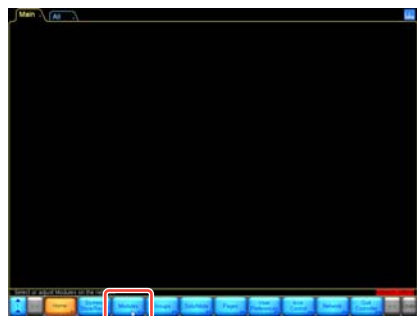

Modules button

- Drag the module scroll bar to the left (or tap the button at the bottom right) to reveal the eight modules of the MY8-LAKE Frame as shown below.

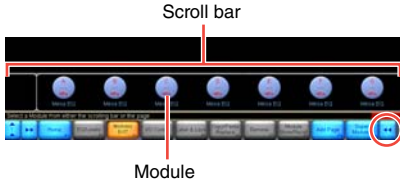

- Tap on one of the eight module icons, then drag the resulting cursor (of blank circles) to the main work area and tap again.

The icons will move from the scroll bar as shown below.



The existing data will be read from the hardware to synchronize the Controller with the MY8-LAKE. The Frame is now online and ready for control and adjustment.

I/O Configuration

This section describes how to configure the input and output routings for a module.

- Tap a module icon in the work area to select it.



Additional functions are activated on the button bar at the bottom of the screen when a module is selected.



I/O Config button

- Tap the [I/O Config] button at the bottom of the screen.

The I/O Config screen (Simplified view) will be displayed by default for the MY8-LAKE card.

The left side of the screen provides summary information regarding the Digital Clock and Input Configuration, as well as selection options for the Analog Output Reference of the host device, Routing Mode and the Operation Mode of the card. Tapping on a magnifying glass icon or on the summary text will open a pop-up screen with additional data; the right side of the screen provides interactive signal flow diagrams.



6. Toggle between the [Host Out Ch] button and the [AES CH] button to select a module input source.

The selected input source will be highlighted in orange.



All modules can be displayed by tapping and holding up/down to scroll.

7. Tap an [Input Mixer] magnifying glass icon.

The Input Mixer screen will be displayed. You can adjust the input level, and route or disconnect input signals to any module by using the ON/OFF buttons and fader controls.

8. Tap the blue arrow at the bottom-right of the screen to close the Input Mixer.

NOTE

- For host devices unrecognized by the MY8-AE96 (such as DIO8), you will need to change the emulation mode of the card to MY8-AT by tapping the [Operation Mode] magnifying glass icon at the bottom left of the screen and reboot the host device.
- The digital clock and input configuration summary can be found at the top left of the screen.

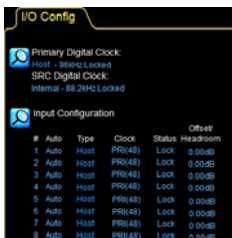

Advanced I/O Configuration (Classic view)

The default output configuration (Simplified view) is routed to the Host inputs (i.e., Host return) and to the AES output from each module. If you want to change the output configuration, you will need to change the view to “Classic view” by following the steps below.

1. Tap the [Routing Mode] magnifying glass icon at the bottom left of the I/O Config screen, then select the “Classic view” from the pop-up menu.

In the Classic view, by default the Mesa Module Outputs A – H are routed simultaneously to both the “Host” returns 1 – 8 and to “AES” channels 1 – 8 just as in the Simplified view.

2. Tap one of the blue boxes in the module’s input mixer block diagram.



The Input Mixer screen will be displayed. You can adjust the input level, and route or disconnect input signals to any module by using the ON/OFF buttons and fader controls.

3. Tap any of the magnifying glass icons on the far right of the screen.



The Output Configuration screen will be displayed allowing you to route any

available audio source to any available output destination.



The orange numbered blocks show which module output is routed to which of the currently selected “Destination” outputs. The currently displayed audio “Source” defaults to show the number of “Module Outputs” channels listed on the left and the visible audio “Destination” defaults to display the “Host” returns. The currently displayed view can be changed by tapping the appropriate left or right arrows beneath the “Source” and “Destination” labels.

NOTE

Tap an orange numbered button to disconnect that source/destination routing only (turns blue); tap a blue numbered button to patch the source to the destination. The Disconnect All button  can be used to disconnect all outputs for the displayed source/destination matrix.

4. Make any changes as required, then tap the blue arrow at the bottom right of the screen to close the Output Configuration screen.

NOTE

You can also close the screen by pressing <Esc>, then pressing <F1> to return to the Home screen.

Levels Screen

The Levels screen provides access to controls for gain, delay, LimiterMax, input mixer, mutes and polarity adjustments. This section describes various example scenarios to highlight key functionality.

1. Tap the [Home] button, then tap a module icon.

If a submenu is not selected, tapping a module icon provides a shortcut to the EQ, Levels and HPF/LPF or XOVER screens for the selected module.

2. Tap the [Levels] tab at the top left of the screen (if not already selected) then tap the red [Output MUTED] button to unmute the Mesa module output.

NOTE

Mesa EQ modules do not have a separate module input mute. Input Router and Input Mixer mutes and connectivity can be reviewed by tapping the associated magnifying glass icon shown below.

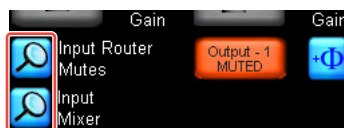

3. Check any associated mute and level settings in the MY8-LAKE host device.

Assuming there is an audio signal passing from the host device into the module, the screen will look similar to that shown below after the input has been unmuted.

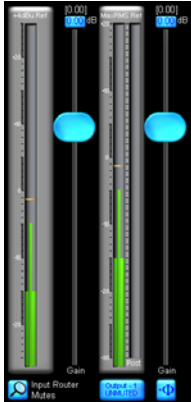

NOTE

The Levels screen always displays active RMS & Peak metering for the input and output channels on the selected module. The fader positions and associated values change as each level type is selected (Gain, Delay, LimiterMax etc.).

4. Tap the [LimiterMax] button to display a submenu containing additional options for RMS and peak limiter controls.



NOTE

- The MaxRMS Level, MaxRMS Corner, MaxRMS Attack, MaxRMS Release and MaxPeak Level controls can be used to set independent peak and RMS output limiters as required for your application.
- These limiter levels are specified in dB units. Yamaha presets for Installation series loudspeakers are tuned assuming 26 dB amp gain, and the "Analog Output Reference" in the I/O Config screen is set to +24 dBu by default for the MY8-LAKE (which is the case for most of Yamaha consoles). However, the limiter levels should be adjusted according to the specific output devices, amplifiers and your particular applications. For use with +18 dBu maximum output devices such as

DM2000, for example, you will need to change the setting of the Analog Output Reference.

5. Tap the [LimiterMax EXIT] button to return to the top level menu.
6. To change polarity, tap the [Enable Polarity] button, then tap a polarity button  (located to the right of the associated channel's mute button).
7. To label a channel, tap the [Label Channel] button, then tap a channel label button. Enter a new name, then tap [OK] (or press <Enter>).



NOTE

- The mute status text is removed from the mute button and mute functionality is temporarily disabled.
- The channel number is appended automatically and does not need to be included in the text label.

8. Tap the [Label Channel] button again to exit channel labeling and enable mute functionality again.

NOTE

The Meter Options submenu includes various other metering options and functionality, some requiring Designer Mode activation before the functions are displayed. For further information on Designer Mode and more detailed Levels screen functionality, refer to the Lake Controller Operation Manual.

PEQ & GEQ Overlays

The Lake Controller software provides powerful EQ overlays that allow layering of EQ using parametric EQ (PEQ) and fixed-band graphic EQ style controls (GEQ).

1. Tap the [Home] button, then tap a module icon.
2. Tap the [EQ] tab at the top of the screen (if not already selected), then tap the [PEQ1] tab.

The EQ tab expands to show the HPF/LPF, PEQ and GEQ tabs.

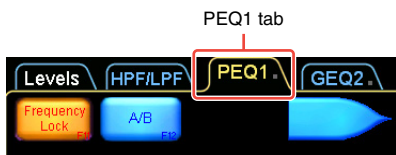

3. Select a Mesa EQ filter by tapping the icon highlighted in orange as illustrated below.



The cursor changes to the same shape for confirmation.

4. Drag the cursor and tap again anywhere on the EQ graph in the main section of the screen.
 - Two filter edit boxes appear at the top of the screen, two corresponding filter points appear on the 0 dB line in the middle of the screen, and a graphical filter editing tool appears at the bottom of the screen.
 - The Mesa EQ filter is a unique filter that allows separate control of both

sides of the filter allowing for fast asymmetrical filter creation.

5. Tap and drag one of the red “X” filter points up or down to boost/cut.

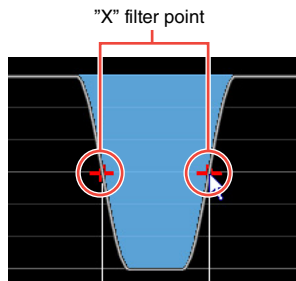

6. Use the filter edit tool at the bottom of the screen to adjust the slopes.

Drag left or right in the numbered zones to adjust the filter as described below.

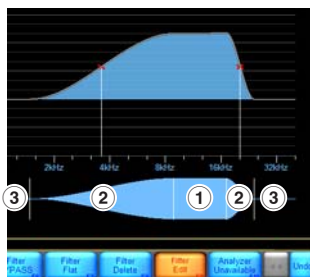

- ① The overall center frequency of the Mesa EQ filter
- ② The center frequency of the each side
- ③ The slope steepness of the each side

7. Tap the [Filter Edit] button to adjust filter gain, frequency center point and slope.

8. Tap any of the blue boxes that appear at the top left of the screen to manually enter specific values if needed.



9. If the [Frequency Lock] button at the top left of the screen is orange, tap the button to disable this function.

NOTE

Frequency Lock is enabled by default and restricts filter selection and frequency adjustment by tapping and dragging on the red 'X' filter points. When enabled, this feature avoids accidental EQ adjustments requiring selection of PEQ filters by tapping on the associated filter box at the top of the screen, and frequency adjustment is only permitted using the EQ filter edit tool described in step 6. For GEQ, this feature forces the user to select a GEQ filter by dragging the EQ selection tool at the bottom of the screen.

10. Tap on the [GEQ2] tab at the top of the screen.

NOTE

The EQ curve from the PEQ1 is visible on GEQ2; the EQ overlays stack on top of each other having a compounding effect on the resulting EQ.

11. Tap on the associated filter point 'X' to select a GEQ2 filter that overlaps the PEQ1 Mesa filter frequency range.

12. Drag the filter point up or down to boost/cut.

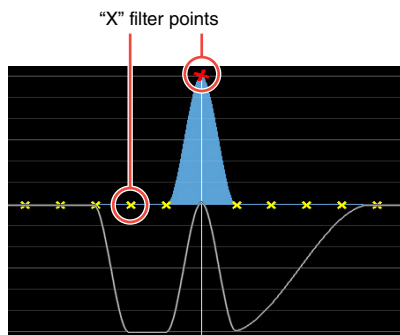

The GEQ filter affects the overall EQ curve indicated by the white line (i.e. the sum of all filters on all PEQ/GEQ overlays that affect the selected module).

HPF/LPF Screen (Mesa mode only)

The HPF/LPF screen provides control of high- and low-pass filters that affect the overall EQ on the selected module. Follow the steps below to set and adjust HPF or LPF filters on a Mesa module.

- 1. Tap the [Home] button, then tap a module icon.**
- 2. Tap the [EQ] tab at the top of the screen (if necessary), then tap the [HPF/LPF] tab.**
- 3. Tap the [HPF Enable] and the [LPF Enable] buttons (so that they turn orange).**



- Tap the HPF filter box at the top left of the screen to select the HPF filter. (The LPF filter box is shown at the top right of the screen when enabled.)

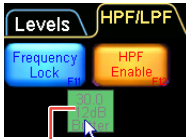

Filter box

- Adjust the HPF frequency center point by dragging the green HPF adjustment tool to the left or right.



HPF adjustment tool

- Tap the [HPF Select] button, then select a desired type of filter from the scroll bar that appears.

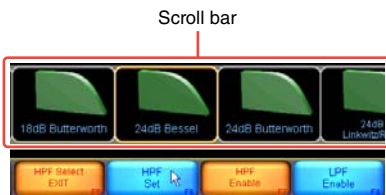

- Tap the [HPF Set] button and tap [Yes] after reading the warning dialog.

NOTE

To view the overall EQ response including the HPF/LPF and PEQ/GEQ filters, tap the [HPF/LPF Functions] button, then tap the [EQ Preferences] button, and finally tap [Full Response]. The white line changes to include the effect of all EQ filters from all PEQ and GEQ overlays that affect the selected module as shown below.

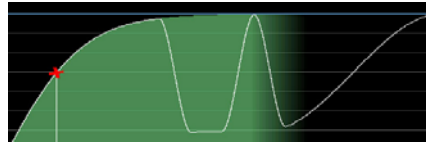

Storing Modules and Systems

Before we move to the next section, store the existing configuration as an individual module file and as a System file.

- Tap the [Home] button, then tap the [Modules] button.
- Select a module icon in the work area, then tap the [Module Store/Recall] button.

NOTE

A module must be selected before the Module Store/Recall function is activated.

- Tap the [New Store] button, then enter a module filename, and then tap [OK] (or press <Enter>).



This stores all module information (levels, x-over and EQ settings) from the selected module as a new module file for future recall. You can recall the file and overwrite a different module.

4. Tap the [Home] button, then tap the [System Store/Recall] button.
5. Tap the [Store System] button, then enter a system name, and finally tap [OK] (or press <Enter>).

This stores all data (frame and module data) in your current system before proceeding to change the device configuration. Input and output routing settings as well as input mixer settings are part of frame data. We recommend you get into a habit of regularly saving your work to minimize the risk of data loss.

NOTE

For further information about storing of Module files, Base Configuration files, System and Sub-System files, refer to the Lake Controller Operation Manual.

Changing the MY8-LAKE Frame Configuration

To review the functionality of the MY8-LAKE card in loudspeaker processor (Contour) mode, the MY8-LAKE Frame configuration must be changed from the default Mesa mode to Contour mode.

1. Tap the [Home] button, then tap the [Modules] button.

2. Make sure that a module is selected, then tap the [I/O Config] button, and finally the [Frame Config] button.



3. Tap the [Contour Reset] button, then tap [Yes] after reading the important warning dialog.



The screen changes to show the module scroll bar and the reconfigured modules will appear on the scroll bar after a few seconds. The Frame can be configured using any of the three available reset options shown above as required.

4. Select one of the MY8-LAKE Contour modules from the module scroll bar and place it in the main work area.

The default 4 x Classic 2-Way Crossover modules appear as shown below.

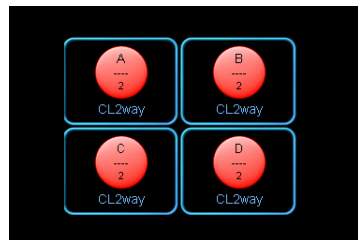

XOVER Screen (Contour mode only)

The XOVER screen is available only on Contour modules when the MY8-LAKE card is configured either in Contour mode or the hybrid Contour/Mesa mode. This section explains features specific to Contour modules. When using loudspeaker presets module files recalled from the "LoadLibrary" folder, the XOVER screen may be hidden and unavailable. This guide assumes the use of the default Classic 2-Way module.

5. Select a module icon, and then tap the [EQ/Levels] button.

If the XOVER screen is not displayed, tap the XOVER tab at the top of the screen.

6. Drag the green crossover adjustment tool at the bottom of the screen to the left or right to adjust the center point of the crossover frequency.



Crossover adjustment tool

7. Tap the right-side of the crossover adjustment tool to select the High channel.

The selected channel is shaded in green.

8. Add a parametric EQ filter to the high channel then drag up or down to boost/cut.

EQ changes on the XOVER screen only affect the selected channel, even if the slope of the EQ filter crosses the frequency range of multiple channels.

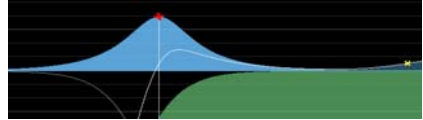

Contour Levels Screen

The Contour Levels screen functions are very similar to those described earlier in the section "Levels Screen" on page 16. This section describes some additional functionality relevant for Contour modules only.

9. Tap the [Levels] tab at the top left of the screen (if not already selected), then tap the red [Input MUTED] button to unmute a default Contour module.



NOTE

- When using Contour loudspeaker preset module files, ensure that the relationship between the module output channel numbers, labels such as Low and High, and the module output to AES or Host routings are carefully verified and adjusted for your particular application prior to allowing any signal to pass to external amplifiers or powered speakers.
- Assuming the routing is correct and there is an audio signal passing from the host device (or via AES inputs if used), the screen will look similar to that

shown below after the module input has been un-muted.

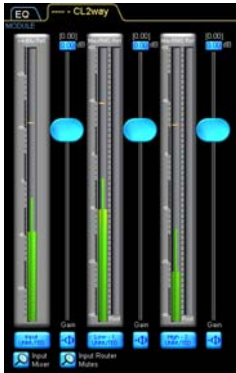

- Contour modules can have between one and six output channels dependent on the module type. The example above shows a 2-way module, with the input channel (far left) and the two output channels (Low & High) to the right.
- For additional information about the Lake Controller, including module grouping, XOVER and HPF/LPF ganging, Designer Mode functionality, and other advanced user options, refer to the Lake Controller Operation Manual.

Appendix

Problems and Warnings

Problems, warnings, and other certain types of information are displayed via the MY8-LAKE panel indicators.

LED	Indicators	Details	Solution
FAULT	Flash	No input source is available.	Refer to “No Sound” in the “Troubleshooting” section.
		The digital clock is slipping.	Ensure the digital clock is locked to a valid source. For details, refer to “Unusual Sound (noise, interruption, or distortion)” in the “Troubleshooting” section, and to the Lake Controller Operation Manual.
		The module output is clipping.	Check the level meters on the module input and output as well as on the console, and reduce the input or output level.
	Lit (static)	An internal error of the card.	Restart the host device. If the problem continues, connect via a NETWORK connector and update the firmware using the Lake Update Utility, and then restart the device.

* If any specific problem should persist, please contact your Yamaha dealer.

Troubleshooting

No Sound	
Is the card recognized correctly by the host device?	In the default setting, the host device will recognize the card as a MY8-AE96 card. For host devices unrecognized by the MY8-AE96 (such as DIO8), you will need to change the emulation mode of the card to MY8-AT by tapping the [Operation Mode] magnifying glass icon at the bottom left of the I/O Config screen in the Lake Controller. For detailed information on the emulation mode settings, refer to the Yamaha Pro Audio website at: http://www.yamahaproaudio.com/
Has the signal been correctly patched to and from the host device?	Check the I/O patching on the console to and from the corresponding MY8-LAKE slot.
Has the signal been connected correctly in the input router and module input mixer?	Verify the input router and input mixer connectivity in the I/O Config screen on the Lake Controller.
Has the signal been correctly routed to the outputs via the Output Configuration screen?	Verify that the module output is correctly connected to the required host return or AES output on the Output Configuration screen on the Lake Controller.
Are all mute points in the MY8-LAKE signal path unmuted?	Check that all Input Router, module Input and module Output Mutes are properly unmuted.
Unusual Sound (noise, interruption, or distortion)	
Is the FAULT LED of the MY8-LAKE illuminated?	A fault could indicate a signal clip or slipping clock.
Is the signal clipping at any point in the signal path?	Check input and output levels on the host device and on the Lake Controller software to ensure that the signal is not clipping at any point during the signal path.
Is the digital clock slipping?	Check the FAULT LED or view "Digital Clock" at top left of the I/O Config screen in the Lake Controller software to check for any digital clocking problems.
Network Control or Communication Problems	
Is the MY8-LAKE card correctly installed and the host device switched on?	Check to ensure that the STATUS LED on the card flashes.
Is the Windows firewall enabled?	Ensure that the Lake Controller is allowed full access through the Windows firewall. Refer to the Lake Controller Operation Manual for further details.
Is the Lake Controller PC connected via a Wireless Access Point?	Connect directly from your Windows PC to the MY8-LAKE card using a Cat5/Cat6 Ethernet cable, and then add a wireless access point once wired connection has proven successful.

Network Control or Communication Problems

Is the IP address on your PC correctly configured?	The default IP Address Config on the MY8-LAKE is Auto - Zero Conf (169.254.x.x); if connectivity problems are encountered, try setting the network adapter of the PC to the same subnet range or use another fixed IP address, such as 192.168.0.x.
Are any Dante-enabled devices present on the network?	Additional network hardware configuration may be required; refer to the Lake Network Configuration Guide.

* If any specific problem should persist, please contact your Yamaha dealer.

Specifications

General Specifications

Sampling Frequency	Mini-YGDAI I/F AES/EBU Input/Output	44.1 kHz, 48 kHz, 88.2 kHz, 96 kHz
	Internal Operating Frequency	96 kHz
Signal Delay	Best case (synchronous 96 kHz to synchronous 96 kHz) from AES input to AES output via module (Contour or Mesa)	0.7185 ms
Power Requirements	maximum 3W	
Temperature range	Operating	0 to 40 °C (32 to 104 °F)
	Storage	-20 to 60 °C (-4 to 140 °F)

I/O Characteristics

Terminal name	Format	Data length	Sampling Frequency	Level	Connector
AES/EBU (In/Out Ch 1-8)	AES/EBU	24 bit	44.1 kHz, 48 kHz, 88.2 kHz, 96 kHz (I/O individually selectable per Ch)	RS422	D-sub 25 pin
NETWORK (Ethernet)	10Base-T/ 100Base-T	-	-	-	RJ-45

Connector Pin Assignment

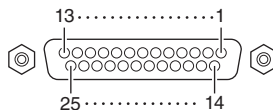

AES/EBU

Signal	Input Ch				Output Ch				Open	GND
	1-2	3-4	5-6	7-8	1-2	3-4	5-6	7-8		
Pin Hot	1	2	3	4	5	6	7	8	9, 11	10, 12, 13, 22, 23, 24, 25
Cold	14	15	16	17	18	19	20	21		

Dimensions

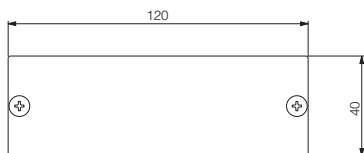
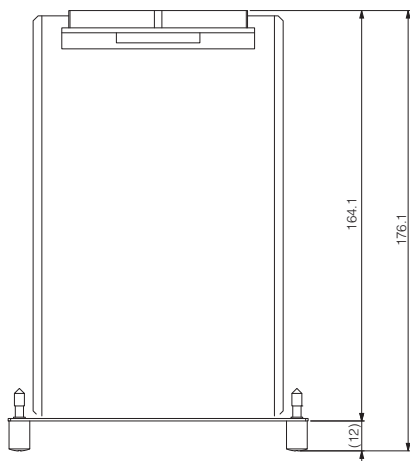

Unit: mm

* Specifications and descriptions in this owner's manual are for information purposes only. Yamaha Corp. reserves the right to change or modify products or specifications at any time without prior notice. Since specifications, equipment or options may not be the same in every locale, please check with your Yamaha dealer.

* Die technischen Daten und Beschreibungen in dieser Bedienungsanleitung dienen nur der Information. Yamaha Corp. behält sich das Recht vor, Produkte oder deren technische Daten jederzeit ohne vorherige Ankündigung zu verändern oder zu modifizieren. Da die technischen Daten, das Gerät selbst oder Sonderzubehör nicht in jedem Land gleich sind, setzen Sie sich im Zweifel bitte mit Ihrem Yamaha-Händler in Verbindung.

- * Les caractéristiques techniques et les descriptions du mode d'emploi ne sont données que pour information. Yamaha Corp. se réserve le droit de changer ou modifier les produits et leurs caractéristiques techniques à tout moment sans aucun avis. Du fait que les caractéristiques techniques, les équipements et les options peuvent différer d'un pays à l'autre, adressez-vous au distributeur Yamaha le plus proche.
- * Las especificaciones y descripciones de este manual del propietario tienen sólo el propósito de servir como información. Yamaha Corp. se reserva el derecho a efectuar cambios o modificaciones en los productos o especificaciones en cualquier momento sin previo aviso. Puesto que las especificaciones, equipos u opciones pueden no ser las mismas en todos los mercados, solicite información a su distribuidor Yamaha.
- * Le specifiche e le descrizioni presenti in questo manuale sono fornite a fini puramente informativi. Yamaha Corp. si riserva il diritto di modificare prodotti o specifiche in qualsiasi momento senza preavviso. Dato che le specifiche, le apparecchiature o le opzioni possono essere diverse da paese a paese, verificarle con il proprio rappresentante Yamaha.
- * Технические характеристики и их описания в данном руководстве пользователя предназначены только для общего сведения. Корпорация Yamaha сохраняет за собой право модифицировать свои изделия и менять их технические характеристики без предварительного уведомления. Поскольку технические характеристики, оборудование и набор возможностей могут зависеть от региона, обращайтесь за информацией к местному представителю корпорации Yamaha.
- * 本使用说明书中的技术规格及介绍仅供参考。YAMAHA公司保留随时更改或修订产品或技术规格的权利, 若确有更改, 恕不事先通知。技术规格、设备或选购件在各个地区可能均会有所不同, 因此如有问题, 请和当地YAMAHA经销商确认。
- * 仕様および外觀は改良のため、予告なく変更することがあります。

Information for Users on Collection and Disposal of Old Equipment



This symbol on the products, packaging, and/or accompanying documents means that used electrical and electronic products should not be mixed with general household waste.
For proper treatment, recovery and recycling of old products, please take them to applicable collection points, in accordance with your national legislation and the Directives 2002/96/EC.
By disposing of these products correctly, you will help to save valuable resources and prevent any potential negative effects on human health and the environment which could otherwise arise from inappropriate waste handling.
For more information about collection and recycling of old products, please contact your local municipality, your waste disposal service or the point of sale where you purchased the items.

[For business users in the European Union]

If you wish to discard electrical and electronic equipment, please contact your dealer or supplier for further information.

[Information on Disposal in other Countries outside the European Union]

This symbol is only valid in the European Union. If you wish to discard these items, please contact your local authorities or dealer and ask for the correct method of disposal.

Verbraucherinformation zur Sammlung und Entsorgung alter Elektrogeräte



Befindet sich dieses Symbol auf den Produkten, der Verpackung und/oder beiliegenden Unterlagen, so sollen benutzte elektrische Geräte nicht mit dem normalen Haushaltsabfall entsorgt werden.

In Übereinstimmung mit Ihren nationalen Bestimmungen und den Richtlinien 2002/96/EC bringen Sie alte Geräte bitte zur fachgerechten Entsorgung, Wiederaufbereitung und Wiederverwendung zu den entsprechenden Sammelstellen.

Durch die fachgerechte Entsorgung der Elektrogeräte helfen Sie, wertvolle Ressourcen zu schützen, und verhindern mögliche negative Auswirkungen auf die menschliche Gesundheit und die Umwelt, die andernfalls durch unsachgerechte Müllentsorgung auftreten könnten.

Für weitere Informationen zum Sammeln und Wiederaufbereiten alter Elektrogeräte kontaktieren Sie bitte Ihre örtliche Stadt- oder Gemeindeverwaltung, Ihren Abfallentsorgungsdienst oder die Verkaufsstelle der Artikel.

[Information für geschäftliche Anwender in der Europäischen Union]

Wenn Sie Elektrogeräte ausrangieren möchten, kontaktieren Sie bitte Ihren Händler oder Zulieferer für weitere Informationen.

[Entsorgungsinformation für Länder außerhalb der Europäischen Union]

Dieses Symbol gilt nur innerhalb der Europäischen Union. Wenn Sie solche Artikel ausrangieren möchten, kontaktieren Sie bitte Ihre örtlichen Behörden oder Ihren Händler und fragen Sie nach der sachgerechten Entsorgungsmethode.

Information concernant la Collecte et le Traitement des déchets d'équipements électriques et électroniques.



Le symbole sur les produits, l'emballage et/ou les documents joints signifie que les produits électriques ou électroniques usagés ne doivent pas être mélangés avec les déchets domestiques habituels.

Pour un traitement, une récupération et un recyclage appropriés des déchets d'équipements électriques et électroniques, veuillez les déposer aux points de collecte prévus à cet effet, conformément à la réglementation nationale et aux Directives 2002/96/EC.

En vous débarrassant correctement des déchets d'équipements électriques et électroniques, vous contribuerez à la sauvegarde de précieuses ressources et à la prévention de potentiels effets négatifs sur la santé humaine qui pourraient advenir lors d'un traitement inapproprié des déchets.

Pour plus d'informations à propos de la collecte et du recyclage des déchets d'équipements électriques et électroniques, veuillez contacter votre municipalité, votre service de traitement des déchets ou le point de vente où vous avez acheté les produits.

[Pour les professionnels dans l'Union Européenne]

Si vous souhaitez vous débarrasser des déchets d'équipements électriques et électroniques veuillez contacter votre vendeur ou fournisseur pour plus d'informations.

[Information sur le traitement dans d'autres pays en dehors de l'Union Européenne]

Ce symbole est seulement valable dans l'Union Européenne. Si vous souhaitez vous débarrasser de déchets d'équipements électriques et électroniques, veuillez contacter les autorités locales ou votre fournisseur et demander la méthode de traitement appropriée.

Información para Usuarios sobre Recolección y Disposición de Equipamiento Viejo



Este símbolo en los productos, embalaje, y/o documentación que se acompaña significa que los productos electrónicos y eléctricos usados no deben ser mezclados con desechos hogareños corrientes.

Para el tratamiento, recuperación y reciclado apropiado de los productos viejos, por favor llévelos a puntos de recolección aplicables, de acuerdo a su legislación nacional y las directivas 2002/96/EC.

Al disponer de estos productos correctamente, ayudará a ahorrar recursos valiosos y a prevenir cualquier potencial efecto negativo sobre la salud humana y el medio ambiente, el cual podría surgir de un inapropiado manejo de los desechos.

Para mayor información sobre recolección y reciclado de productos viejos, por favor contacte a su municipio local, su servicio de gestión de residuos o el punto de venta en el cual usted adquirió los artículos.

[Para usuarios de negocios en la Unión Europea]

Si usted desea deshacerse de equipamiento eléctrico y electrónico, por favor contacte a su vendedor o proveedor para mayor información.

[Información sobre la Disposición en otros países fuera de la Unión Europea]

Este símbolo sólo es válido en la Unión Europea. Si desea deshacerse de estos artículos, por favor contacte a sus autoridades locales y pregunte por el método correcto de disposición.

Informazioni per gli utenti sulla raccolta e lo smaltimento di vecchia attrezzatura



Questo simbolo sui prodotti, sull'imballaggio, e/o sui documenti che li accompagnano significa che i prodotti elettriche e elettroniche non dovrebbero essere mischiati con i rifiuti domestici generici.

Per il trattamento, recupero e riciclaggio appropriati di vecchi prodotti, li porti, prego, ai punti di raccolta appropriati, in accordo con la Sua legislazione nazionale e le direttive 2002/96/CE.

Smaltendo correttamente questi prodotti, Lei aiuterà a salvare risorse preziose e a prevenire alcuni potenziali effetti negativi sulla salute umana e l'ambiente, che altrimenti potrebbero sorgere dal trattamento improprio dei rifiuti.

Per ulteriori informazioni sulla raccolta e il riciclaggio di vecchi prodotti, prego contatti la Sua amministrazione comunale locale, il Suo servizio di smaltimento dei rifiuti o il punto vendita dove Lei ha acquistato gli articoli.

[Per utenti imprenditori dell'Unione europea]

Se Lei desidera disfarsi di attrezzatura elettrica ed elettronica, prego contatti il Suo rivenditore o fornitore per ulteriori informazioni.

[Informazioni sullo smaltimento negli altri Paesi al di fuori dell'Unione europea]

Questo simbolo è valido solamente nell'Unione europea. Se Lei desidera disfarsi di questi articoli, prego contatti la Sue autorità locali o il rivenditore e richieda la corretta modalità di smaltimento.

Important Notice: Guarantee Information for customers in European Economic Area (EEA) and Switzerland

<p>Important Notice: Guarantee Information for customers in EEA* and Switzerland For detailed guarantee information about this Yamaha product, and Pan-EEA* and Switzerland warranty service, please either visit the website address below (Printable file is available at our website) or contact the Yamaha representative office for your country. * EEA: European Economic Area</p>	<p>English</p>
<p>Wichtiger Hinweis: Garantie-Information für Kunden in der EWR* und der Schweiz Für nähere Garantie-Information über dieses Produkt von Yamaha, sowie über den Pan-EEA* und Schweizer Garantieservice, besuchen Sie bitte unsere Website (Druckbare Datei ist verfügbar auf unserer Website), oder wenden Sie sich an den für Ihr Land zuständigen Yamaha-Vertrieb. *EWR: Europäischer Wirtschaftsraum</p>	<p>Deutsch</p>
<p>Remarque importante: Informations de garantie pour les clients de l'EEE* et la Suisse Pour des informations plus détaillées sur la garantie de ce produit Yamaha et sur le service de garantie applicable dans l'ensemble de l'EEE* ainsi qu'en Suisse, consultez notre site Web à l'adresse ci-dessous (le fichier imprimable est disponible sur notre site Web) ou contactez directement Yamaha dans votre pays de résidence. * EEE : Espace Économique Européen</p>	<p>Français</p>
<p>Belangrijke mededeling: Garantie-informatie voor klanten in de EER* en Zwitserland Voor gedetailleerde garantie-informatie over dit Yamaha-product en de garantieservice in heel de EER* en Zwitserland, gaar u naar onze website (Drukbaar bestand is beschikbaar op onze website) of neem u contact op met de vertegenwoordiging van Yamaha in uw land. * EER: Europees Economisch Ruimtegebied</p>	<p>Nederlands</p>
<p>Avviso importante: informazione sobre a garantia para os clientes da AEE* e da Suíça Para una información detallada sobre este producto Yamaha y sobre el soporte de garantía en la zona EEE* y Suiza, visite la dirección web que se incluye más abajo (la versión del archivo para imprimir está disponible en nuestro sitio web) o póngase en contacto con el representante de Yamaha en su país. * EEE: Espacio Económico Europeo</p>	<p>Español</p>
<p>Avviso importante: informazioni sulla garanzia per i clienti residenti nell'EEA* e in Svizzera Per informazioni dettagliate sulla garanzia relativa a questo prodotto Yamaha e l'assistenza in garanzia nel paese EEA* o in Svizzera, potete consultare il nostro sito web (il file stampabile è disponibile in formato stampabile) oppure contattate l'ufficio di rappresentanza locale della Yamaha. * EEA: Area Economica Europea</p>	<p>Italiano</p>
<p>Aviso importante: informações sobre as garantias para clientes da AEE* e da Suíça Para obter uma informação pormenorizada sobre este produto da Yamaha e sobre o serviço de garantia na AEE* e na Suíça, visite o website o site a seguir (o arquivo para impressão está disponível no nosso site) ou entre em contato com o escritório de representação da Yamaha no seu país. * AEE: Área Económica Europeia</p>	<p>Português</p>
<p>Знаете ли ви нашето обещание: Информацията за гаранцията за клиентите в ЕЕА* и Швейцария За подробна информация за гаранцията и услугите за поддръжка на този продукт Yamaha в ЕЕА* и Швейцария, моля, посетете нашия уебсайт (версията за печат е налична в нашия уебсайт) или се свържете с местния представител на Yamaha в страната ви. * ЕЕА: Европейски икономически район</p>	<p>Български</p>
<p>Viktigt meddelande: Garantiuplysninger til kunder i EEO* og Schweiz De kan finde detaljerede garantioplysninger om dette Yamaha-produkt og det fælles garanti-/servicecenter for EEO* og Schweiz ved at besøge det website, der er angivet nedenfor (der findes en fil, som kan udskrives), eller ved at kontakte Yamahas nationale repræsentationskontor i det land, hvor De bor. * EEO: Det Europæiske Økonomiske Område</p>	<p>Dansk</p>
<p>Viktig merknad: Garantiinformasjon for kunder i EEO* og Sveits Detaljerte garantiinformasjon om dette Yamaha-produktet og garantienservice for hele EEO*-området* og Sveits kan fås enten ved å besøke adresserte nettstedet (utskriftsfil finnes på vår nettside) eller kontakte kontaktet i Yamaha-kontoret i landet der du bor. * EEO: Det europeiske økonomiske samarbeidsområdet</p>	<p>Norsk</p>

<p>Tärkeä Ilmoitus: Takuuehdot Euroopan talousalueen (ETA*) ja Sveitsin asiakkaille Tämän Yamaha-tuotteen sekä ETA-alueen ja Sveitsin takuuta koskevat yksityiskohtaiset tiedot saatte alla olevasta nettositeltestä. (Tulostettava tiedosto saatavana suosituksemme.) Voitte myös ottaa yhteyttä paikallisellen Yamahan edustajaan. *ETA: Euroopan talousalue</p>	<p>Suomi</p>
<p>Ważne: Warunki gwarancyjne obowiązujące w EOG* i Szwajcarii Aby dowiedzieć się więcej na temat warunków gwarancyjnych tego produktu firmy Yamaha i serwisu gwarancyjnego w całym EOG* i Szwajcarii, odwiedź naszą stronę internetową lub skontaktujcie się z przedstawicielstwem firmy Yamaha w swoim kraju. * EOG – Europejski Obszar Gospodarczy</p>	<p>Polski</p>
<p>Důležité oznámení: Zánovní informace pro zákazníky v EHS* a ve Švýcarsku Podrobné zánovní informace o tomto produktu Yamaha a zánovním servisu v celém EHS* a ve Švýcarsku naleznete na níže uvedené webové adrese (soubor k tisku je dostupný na našich webových stránkách) nebo se můžete obrátit na zástupce firmy Yamaha ve své zemi. * EHS: Evropský hospodářský prostor</p>	<p>Česky</p>
<p>Fontos figyelmeztetés: Garancia-információk az EGT* területén és Svájcban élő vásárlók számára A jelen Yamaha termékre vonatkozó részletes garancia-információk, valamint az EGT-re és Svájcra kiterjedő garanciális feltételek, érdeklődés esetén megtekinthetők a honlapunkon (a nyomtatandó fájlok itt találhatók), vagy pedig helyben kapcsolatba léphetek az országában működő Yamaha képviselői irodával. * EGT: Európai Gazdasági Térség</p>	<p>Magyar</p>
<p>Ouline märkusi: Garantiteave Euroopa Majanduspiirkonna (EMP)* ja Sveitsi Klientidele Täpsemat teabes saamiseks saate Yamaha toote garantii ning kogu Euroopa Majanduspiirkonnale ja Sveitsi garantiteeninduse kohta, külastage palun veebisaiti alljärgneval aadressil (meie saidil on saadaval printitava faili või pöördeute Teie riigioni Yamaha esinduse poolse). * EMP: Euroopa Majanduspiirkond</p>	<p>Eesti keel</p>
<p>Svargs svarstipulums: garantijas informācija klientiem EEZ* un Šveicā Lai saņemtu detaļāku garantijas informāciju par šo Yamaha produktu, kā arī garantijas apakšpošanu EEZ* un Šveicā, lūdzam apmeklēt mūsu tīmekļa vietni (mūsu tīmekļa vietnē ir pieejams drukājams fails) vai sazināties ar jūsu valsts pārstāvniecību Yamaha parastīveidū. * EEZ: Eiropas Ekonomikas zona</p>	<p>Latviešu</p>
<p>Demosis: Informācija dal garantijas pirkējiem EEE* ir Šveicarpilsoņiem Jei reikia išsamios informacijos apie šį „Yamaha“ produktą ir jo techninę priežiūrą visoje EEE* ir Šveicarpilso, apsilankykite mūsų svetainėje (toliau nurodytą adresą) (svetainėje yra spausdinamas failas) arba kreipkitės į „Yamaha“ atstovą bei savo šalį.</p>	<p>Lietuvių kalba</p>
<p>Dobře zpozornění: Informácie o záruce pro zákazníků v EHP* a Švajčiarsku Podrobné informácie o záruke týkajúcej sa tohto produktu od spoločnosti Yamaha a garancijném servise v EHP* a Švajčiarsku nájdete na našej stránke (naša stránka má k dispozícii súbor na tlač) alebo sa obráťte na zástupcu spoločnosti Yamaha vo svojom krajine. * EHP: Európsky hospodársky priestor</p>	<p>Slovenčina</p>
<p>Pomoebno obavestie: Informácie o garancii za kupcov v EGP* in Švicí Za podrobnejšie informácie o tem Yamahinem izdelku ter garancijnem servisu v celotnem EGP in Švicí, obišite spletno mesto, ki je navedeno spodaj (natisljiva datoteka je na voljo na našem spletnem mestu), ali se obrnite na Yamahinega predstavnika v svoji državi. * EGP: Evropski gospodarski prostor</p>	<p>Slovenshina</p>
<p>Важно Сводбешение: Информация за гаранцията за клиентите в ЕИП* и Швейцария За подробна информация за гаранцията за този продукт на клиента в ЕИП* и Швейцария и гаранционното обслужване в пан-европейската зона на ЕИП* и Швейцария или поддръжката по телефона, моля, посетете нашия уебсайт (файл за печат е наличен на нашия уебсайт) или се свържете с местния представител на Yamaha във вашата страна. *ЕИП: Европейски икономически район</p>	<p>Български език</p>
<p>Notificarea importantă: Informații despre garanție pentru clienții din SEE* și Elveția Pentru informații detaliate privind acest produs Yamaha și serviciile de garanție Pan-SEE* și Elveția, vizitați site-ul în adresa de mai jos (fișierul imprimabil este disponibil pe site-ul nostru) sau contactați biroul reprezentanței Yamaha din țara dumneavoastră. * SEE: Spațiul Economic European</p>	<p>Limba română</p>

<http://europe.yamaha.com/warranty/>

For details of products, please contact your nearest Yamaha representative or the authorized distributor listed below.

Pour plus de détails sur les produits, veuillez-vous adresser à Yamaha ou au distributeur le plus proche de vous figurant dans la liste suivante.

Die Einzelheiten zu Produkten sind bei Ihrer unten aufgeführten Niederlassung und bei Yamaha Vertragshändlern in den jeweiligen Bestimmungsländern erhältlich.

Para detalles sobre productos, contacte su tienda Yamaha más cercana o el distribuidor autorizado que se lista debajo.

NORTH AMERICA

CANADA

Yamaha Canada Music Ltd.
135 Milner Avenue, Scarborough, Ontario,
M1S 3R1, Canada
Tel: 416-298-1311

U.S.A.

Yamaha Corporation of America
6600 Orangehorpe Ave., Buena Park, Calif. 90620,
U.S.A.
Tel: 714-522-9011

CENTRAL & SOUTH AMERICA

MEXICO

Yamaha de México S.A. de C.V.
Cálz. Javier Rojo Gómez #1149,
Col. Guadalupe del Moral
C.P. 09300, México, D.F., México
Tel: 55-5804-0600

BRAZIL

Yamaha Musical do Brasil Ltda.
Rua Joaquim Floriano, 913 + 4º andar, Itaim Bibi,
CEP 04534-013 Sao Paulo, SP, BRAZIL
Tel: 011-3704-1377

ARGENTINA

Yamaha Music Latin America, S.A.
Sucursal de Argentina
Olga Cossetini 1553, Piso 4 Norte
Madero Este-C1107CEK
Buenos Aires, Argentina
Tel: 011-4119-7000

PANAMA AND OTHER LATIN

AMERICAN COUNTRIES/

CARIBBEAN COUNTRIES

Yamaha Music Latin America, S.A.
Torre Banco General, Piso 7, Urbanización Marbella,
Calle 47 y Aquilino de la Guardia,
Ciudad de Panamá, Panamá
Tel: +507-269-5311

EUROPE

THE UNITED KINGDOM/IRELAND

Yamaha Music Europe GmbH (UK)
Sherbourne Drive, Tilbrook, Milton Keynes,
MK7 8BL, England
Tel: 01908-366700

GERMANY

Yamaha Music Europe GmbH
Siemensstraße 22-34, 25462 Rellingen, Germany
Tel: 04101-3030

SWITZERLAND/LIECHTENSTEIN

Yamaha Music Europe GmbH
Branch Switzerland in Zürich
Seefeldstrasse 94, 8008 Zürich, Switzerland
Tel: 044-387-8080

AUSTRIA/BULGARIA

Yamaha Music Europe GmbH Branch Austria
Schleiergasse 20, A-1100 Wien, Austria
Tel: 01-60203900

CZECH REPUBLIC/HUNGARY/

ROMANIA/SLOVAKIA/SLOVENIA

Yamaha Music Europe GmbH
Branch Austria (Central Eastern Europe Office)
Schleiergasse 20, A-1100 Wien, Austria
Tel: 01-602039025

POLAND/LITHUANIA/LATVIA/ESTONIA

Yamaha Music Europe GmbH
Branch Sp.z o.o. Oddział w Polsce
ul. 17 Sycznia 56, PL-02-146 Warszawa, Poland
Tel: 022-500-2925

MALTA

Olimpus Music Ltd.
The Emporium, Level 3, St. Louis Street Msida
MSD06
Tel: 02133-2144

THE NETHERLANDS/ BELGIUM/LUXEMBOURG

Yamaha Music Branch Benelux
Clarissenhof 5-6, 4133 AB Vianen, The Netherlands
Tel: 0347-358 040

FRANCE

Yamaha Music Europe
BP 70-77312 Marne-la-Vallée Cedex 2, France
Tel: 01-64-61-4000

ITALY

Yamaha Music Europe GmbH, Branch Italy
Viale Italia 88, 20020 Lainate (Milano), Italy
Tel: 02-935-771

SPAIN/PORTUGAL

**Yamaha Music Europe GmbH Ibérica, Sucursal
en España**
Ctra. de la Corona km. 17, 200, 28230
Las Rozas (Madrid), Spain
Tel: +34-902-39-8888

GREECE

Philippos Nakas S.A. The Music House
147 Skiathou Street, 112-55 Athens, Greece
Tel: 01-228 2160

SWEDEN/FINLAND/ICELAND

**Yamaha Music Europe GmbH Germany filial
Scandinavien**
J. A. Wettergrens Gata 1, Box 30053
S-400 43 Göteborg, Sweden
Tel: 031 89 34 00

DENMARK

**Yamaha Music Europe GmbH, Tyskland – filial
Denmark**
Generatorvej 6A, DK-2730 Herlev, Denmark
Tel: 44 92 49 00

NORWAY

**Yamaha Music Europe GmbH Germany -
Norwegian Branch**
Grini Næringspark 1, N-1345 Østerås, Norway
Tel: 67 16 77 70

RUSSIA

Yamaha Music (Russia)
Room 37, bld. 7, Kievskaya street, Moscow,
121059, Russia
Tel: 495 626 5005

OTHER EUROPEAN COUNTRIES

Yamaha Music Europe GmbH
Siemensstraße 22-34, 25462 Rellingen, Germany
Tel: +49-4101-3030

AFRICA

Yamaha Corporation,
Asia-Pacific Sales & Marketing Group
Nakazawa-cho 10-1, Naka-ku, Hamamatsu,
Japan 430-8650
Tel: +81-53-460-2303

MIDDLE EAST

TURKEY/CYPRUS

Yamaha Music Europe GmbH
Siemensstraße 22-34, 25462 Rellingen, Germany
Tel: 04101-3030

OTHER COUNTRIES

Yamaha Music GulfFZE
LOB 16-513, P.O.Box 17328, Jubel Ali,
Dubai, United Arab Emirates
Tel: +971-4-881-5868

ASIA

THE PEOPLE'S REPUBLIC OF CHINA

Yamaha Music & Electronics (China) Co., Ltd.
2F, Yunhedasha, 1818 Xinzha-lu, Jingan-qu,
Shanghai, China
Tel: 021-6247-2211

INDIA

Yamaha Music India Pvt. Ltd.
Spazedge building, Ground Floor, Tower A, Sector
47, Gurgaon- Sohna Road, Gurgaon, Haryana, India
Tel: 0124-485-3300

INDONESIA

PT. Yamaha Musik Indonesia (Distributor)
PT. Nusantara
Gedung Yamaha Music Center, Jalan Jend. Gatot
Subroto Kav. 4, Jakarta 12930, Indonesia
Tel: 021-520-2577

KOREA

Yamaha Music Korea Ltd.
8F, 9F, Dongsung Bldg. 158-9 Samsung-Dong,
Kangnam-Gu, Seoul, Korea
Tel: 02-3467-3300

MALAYSIA

Yamaha Music (Malaysia) Sdn., Bhd.
Lot 8, Jalan Perbandaran, 47301 Kelana Jaya,
Petaling Jaya, Selangor, Malaysia
Tel: 03-78030900

SINGAPORE

Yamaha Music (Asia) PRIVATE LIMITED
Blk 202 Hougang Street 21, #02-00,
Singapore 530202, Singapore
Tel: 6747-4374

TAIWAN

Yamaha KHS Music Co., Ltd.
3F, #6, Sec.2, Nan Jing E. Rd. Taipei.
Taiwan 104, R.O.C.
Tel: 02-2511-8688

THAILAND

Siam Music Yamaha Co., Ltd.
4, 6, 15 and 16th floor, Siam Motors Building,
891/1 Rama 1 Road, Wangmai,
Pathumwan, Bangkok 10330, Thailand
Tel: 02-215-2622

OTHER ASIAN COUNTRIES

Yamaha Corporation,
Asia-Pacific Sales & Marketing Group
Nakazawa-cho 10-1, Naka-ku, Hamamatsu,
Japan 430-8650
Tel: +81-53-460-2303

OCEANIA

AUSTRALIA

Yamaha Music Australia Pty. Ltd.
Level 1, 99 Queensbridge Street, Southbank,
Victoria 3006, Australia
Tel: 3-9693-5111

COUNTRIES AND TRUST

TERRITORIES IN PACIFIC OCEAN

Yamaha Corporation,
Asia-Pacific Sales & Marketing Group
Nakazawa-cho 10-1, Naka-ku, Hamamatsu,
Japan 430-8650
Tel: +81-53-460-2303



Yamaha Pro Audio global web site

<http://www.yamahaproaudio.com/>

Yamaha Manual Library

<http://www.yamaha.co.jp/manual/>