



MIXING CONSOLE

MG12XUK

Owner's Manual

PRECAUTIONS **pages 4 to 6**

Quick Start Guide **pages 9 to 11**

Troubleshooting **pages 18 to 20**

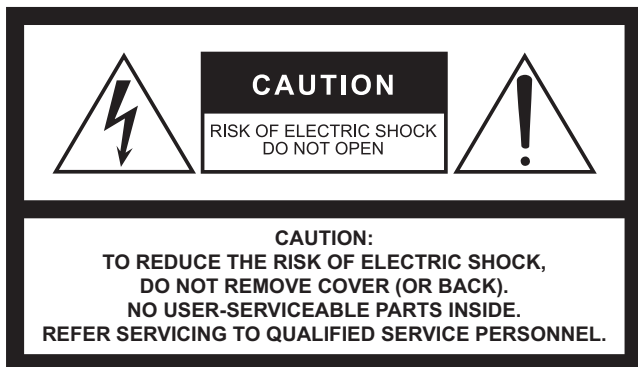

The above warning is located on the rear of the unit.



L'avertissement ci-dessus est situé sur l'arrière de l'unité.

Explanation of Graphical Symbols Explication des symboles



The lightning flash with arrowhead symbol within an equilateral triangle is intended to alert the user to the presence of uninsulated "dangerous voltage" within the product's enclosure that may be of sufficient magnitude to constitute a risk of electric shock to persons. L'éclair avec une flèche à l'intérieur d'un triangle équilatéral est destiné à attirer l'attention de l'utilisateur sur la présence d'une « tension dangereuse » non isolée à l'intérieur de l'appareil, pouvant être suffisamment élevée pour constituer un risque d'électrocution.



The exclamation point within an equilateral triangle is intended to alert the user to the presence of important operating and maintenance (servicing) instructions in the literature accompanying the product.

Le point d'exclamation à l'intérieur d'un triangle équilatéral est destiné à attirer l'attention de l'utilisateur sur la présence d'instructions importantes sur l'emploi ou la maintenance (réparation) de l'appareil dans la documentation fournie.

IMPORTANT SAFETY INSTRUCTIONS

- 1 Read these instructions.
- 2 Keep these instructions.
- 3 Heed all warnings.
- 4 Follow all instructions.
- 5 Do not use this apparatus near water.
- 6 Clean only with dry cloth.
- 7 Do not block any ventilation openings. Install in accordance with the manufacturer's instructions.
- 8 Do not install near any heat sources such as radiators, heat registers, stoves, or other apparatus (including amplifiers) that produce heat.
- 9 Do not defeat the safety purpose of the polarized or grounding-type plug. A polarized plug has two blades with one wider than the other. A grounding type plug has two blades and a third grounding prong. The wide blade or the third prong are provided for your safety. If the provided plug does not fit into your outlet, consult an electrician for replacement of the obsolete outlet.
- 10 Protect the power cord from being walked on or pinched particularly at plugs, convenience receptacles, and the point where they exit from the apparatus.
- 11 Only use attachments/accessories specified by the manufacturer.
- 12 Use only with the cart, stand, tripod, bracket, or table specified by the manufacturer, or sold with the apparatus. When a cart is used, use caution when moving the cart/apparatus combination to avoid injury from tip-over.
- 13 Unplug this apparatus during lightning storms or when unused for long periods of time.
- 14 Refer all servicing to qualified service personnel. Servicing is required when the apparatus has been damaged in any way, such as power-supply cord or plug is damaged, liquid has been spilled or objects have fallen into the apparatus, the apparatus has been exposed to rain or moisture, does not operate normally, or has been dropped.



WARNING
TO REDUCE THE RISK OF FIRE OR ELECTRIC SHOCK, DO NOT EXPOSE THIS APPARATUS TO RAIN OR MOISTURE.

(UL60065_03)

PRÉCAUTIONS CONCERNANT LA SÉCURITÉ

- 1 Lire ces instructions.
- 2 Conserver ces instructions.
- 3 Tenir compte de tous les avertissements.
- 4 Suivre toutes les instructions.
- 5 Ne pas utiliser ce produit à proximité d'eau.
- 6 Nettoyer uniquement avec un chiffon propre et sec.
- 7 Ne pas bloquer les orifices de ventilation. Installer l'appareil conformément aux instructions du fabricant.
- 8 Ne pas installer l'appareil à proximité d'une source de chaleur comme un radiateur, une bouche de chaleur, un poêle ou tout autre appareil (y compris un amplificateur) produisant de la chaleur.
- 9 Ne pas modifier le système de sécurité de la fiche polarisée ou de la fiche de terre. Une fiche polarisée dispose de deux broches dont une est plus large que l'autre. Une fiche de terre dispose de deux broches et d'une troisième pour le raccordement à la terre. Cette broche plus large ou cette troisième broche est destinée à assurer la sécurité de l'utilisateur. Si la fiche équipant l'appareil n'est pas compatible avec les prises de courant disponibles, faire remplacer les prises par un électricien.
- 10 Acheminer les cordons d'alimentation de sorte qu'ils ne soient pas piétinés ni coincés, en faisant tout spécialement attention aux fiches, prises de courant et au point de sortie de l'appareil.
- 11 Utiliser exclusivement les fixations et accessoires spécifiés par le fabricant.
- 12 Utiliser exclusivement le chariot, le stand, le trépied, le support ou la table recommandés par le fabricant ou vendus avec cet appareil. Si l'appareil est posé sur un chariot, déplacer le chariot avec précaution pour éviter tout risque de chute et de blessure.
- 13 Débrancher l'appareil en cas d'orage ou lorsqu'il doit rester hors service pendant une période prolongée.
- 14 Confier toute réparation à un personnel qualifié. Faire réparer l'appareil s'il a subi tout dommage, par exemple si la fiche ou le cordon d'alimentation est endommagé, si du liquide a coulé ou des objets sont tombés à l'intérieur de l'appareil, si l'appareil a été exposé à la pluie ou à de l'humidité, si l'appareil ne fonctionne pas normalement ou est tombé.



AVERTISSEMENT
POUR RÉDUIRE LES RISQUES D'INCENDIE OU DE DÉCHARGE ÉLECTRIQUE, N'EXPOSEZ PAS CET APPAREIL À LA PLUIE OU À L'HUMIDITÉ.

(UL60065_03)

FCC INFORMATION (U.S.A.)

1. IMPORTANT NOTICE: DO NOT MODIFY THIS UNIT!

This product, when installed as indicated in the instructions contained in this manual, meets FCC requirements. Modifications not expressly approved by Yamaha may void your authority, granted by the FCC, to use the product.

2. IMPORTANT:

When connecting this product to accessories and/or another product use only high quality shielded cables. Cable/s supplied with this product MUST be used. Follow all installation instructions. Failure to follow instructions could void your FCC authorization to use this product in the USA.

3. NOTE:

This product has been tested and found to comply with the requirements listed in FCC Regulations, Part 15 for Class "B" digital devices. Compliance with these requirements provides a reasonable level of assurance that your use of this product in a residential environment will not result in harmful interference with other electronic devices. This equipment generates/uses radio frequencies and, if not installed and used according to the instructions found in the users manual, may cause interference harmful to the operation of other electronic devices. Compliance with FCC regulations does not guarantee that interference will not occur in all

installations. If this product is found to be the source of interference, which can be determined by turning the unit "OFF" and "ON", please try to eliminate the problem by using one of the following measures:

Relocate either this product or the device that is being affected by the interference.

Utilize power outlets that are on different branch (circuit breaker or fuse) circuits or install AC line filter/s.

In the case of radio or TV interference, relocate/reorient the antenna. If the antenna lead-in is 300 ohm ribbon lead, change the lead-in to co-axial type cable.

If these corrective measures do not produce satisfactory results, please contact the local retailer authorized to distribute this type of product. If you can not locate the appropriate retailer, please contact Yamaha Corporation of America, Electronic Service Division, 6600 Orangethorpe Ave, Buena Park, CA90620

The above statements apply ONLY to those products distributed by Yamaha Corporation of America or its subsidiaries.

(class B)

COMPLIANCE INFORMATION STATEMENT (DECLARATION OF CONFORMITY PROCEDURE)

Responsible Party : Yamaha Corporation of America
Address : 6600 Orangethorpe Ave., Buena Park, Calif. 90620
Telephone : 714-522-9011
Type of Equipment : Mixing Console
Model Name : MG12XUK

This device complies with Part 15 of the FCC Rules.

Operation is subject to the following two conditions:

- 1) this device may not cause harmful interference, and
- 2) this device must accept any interference received including interference that may cause undesired operation.

See user manual instructions if interference to radio reception is suspected.

(FCC DoC)

Information for users on collection and disposal of old equipment:



This symbol on the products, packaging, and/or accompanying documents means that used electrical and electronic products should not be mixed with general household waste. For proper treatment, recovery and recycling of old products, please take them to applicable collection points, in accordance with your national legislation.

By disposing of these products correctly, you will help to save valuable resources and prevent any potential negative effects on human health and the environment which could otherwise arise from inappropriate waste handling.

For more information about collection and recycling of old products, please contact your local municipality, your waste disposal service or the point of sale where you purchased the items.

For business users in the European Union:

If you wish to discard electrical and electronic equipment, please contact your dealer or supplier for further information.

Information on Disposal in other Countries outside the European Union:

This symbol is only valid in the European Union. If you wish to discard these items, please contact your local authorities or dealer and ask for the correct method of disposal.

(weee_eu_en_02)

PRECAUTIONS

PLEASE READ CAREFULLY BEFORE PROCEEDING

Please keep this manual in a safe place for future reference.



WARNING

Always follow the basic precautions listed below to avoid the possibility of serious injury or even death from electrical shock, short-circuiting, damages, fire or other hazards. These precautions include, but are not limited to, the following:

Power supply/AC power adaptor

- Do not place the power cord near heat sources such as heaters or radiators, and do not excessively bend or otherwise damage the cord, place heavy objects on it, or place it in a position where anyone could walk on, trip over, or roll anything over it.
- Only use the voltage specified as correct for the device. The required voltage is printed on the name plate of the device.
- Use the specified adaptor only. Using the wrong adaptor can result in damage to the device or overheating.
- Check the electric plug periodically and remove any dirt or dust which may have accumulated on it.
- When setting up the device, make sure that the AC outlet you are using is easily accessible. If some trouble or malfunction occurs, immediately turn off the power switch and disconnect the plug from the outlet. Even when the power switch is turned off, as long as the power cord is not unplugged from the wall AC outlet, the device will not be disconnected from the power source.
- Remove the electric plug from the outlet when the device is not to be used for extended periods of time, or during electrical storms.

Do not open

- This device contains no user-serviceable parts. Do not open the device or attempt to disassemble the internal parts or modify them in any way. If it should appear to be malfunctioning, discontinue use immediately and have it inspected by qualified Yamaha service personnel.

Water warning

- Do not expose the device to rain, use it near water or in damp or wet conditions, or place on it any containers (such as vases, bottles or glasses) containing liquids which might spill into any openings. If any liquid such as water seeps into the device, turn off the power immediately and unplug the power cord from the AC outlet. Then have the device inspected by qualified Yamaha service personnel.
- Never insert or remove an electric plug with wet hands.

Hearing loss

- Avoid setting all equalizer controls and faders to their maximum. Depending on the condition of the connected devices, doing so may result in feedback that can cause hearing loss and damage the speakers.

- Do not use headphones for a long period of time at a high or uncomfortable volume level, since this can cause permanent hearing loss. If you experience any hearing loss or ringing in the ears, consult a physician.
- Before connecting the device to other devices, turn off the power for all devices. Also, before turning the power of all devices on or off, make sure that all volume levels are set to the minimum. Failing to do so may result in hearing loss, electric shock, or device damage.
- When turning on the AC power in your audio system, always turn on the power amplifier LAST, to avoid hearing loss and speaker damage. When turning the power off, the power amplifier should be turned off FIRST for the same reason.

Fire warning

- Do not place any burning items or open flames near the device, since they may cause a fire.

If you notice any abnormality

- If any of the following problems occur, immediately turn off the power switch and disconnect the electric plug from the outlet.
 - The power cord or plug becomes frayed or damaged.
 - Unusual smells or smoke are emitted.
 - Unusual object has been dropped into the device.
 - There is a sudden loss of sound during use of the device.
 - Cracks or other visible damage appear on the device. Then have the device inspected or repaired by qualified Yamaha service personnel.
- If this device or the AC power adaptor should be dropped or damaged, immediately turn off the power switch, disconnect the electric plug from the outlet, and have the device inspected by qualified Yamaha service personnel.



CAUTION

Always follow the basic precautions listed below to avoid the possibility of physical injury to you or others, or damage to the device or other property. These precautions include, but are not limited to, the following:

Power supply/AC power adaptor

- Do not cover or wrap the AC power adaptor with a cloth or blanket.
- When removing the electric plug from the device or an outlet, always hold the plug itself and not the cord. Pulling by the cord can damage it.

Location

- Do not place the device in an unstable position where it might accidentally fall over and cause injuries.
- Do not place the device in a location where it may come into contact with corrosive gases or salt air. Doing so may result in malfunction.
- Before moving the device, remove all connected cables.

Maintenance

- Remove the power plug from the AC outlet when cleaning the device.

Handling caution

- Do not rest your weight on the device or place heavy objects on it. Avoid applying excessive force to the buttons, switches or connectors to prevent injuries.
- Avoid pulling the connected cables to prevent injuries or damage to the device.

Yamaha cannot be held responsible for damage caused by improper use or modifications to the device,

NOTICE

To avoid the possibility of malfunction/damage to the product, damage to data, or damage to other property, follow the notices below.

■ Handling and maintenance

- Do not use the device in the vicinity of a TV, radio, AV equipment, mobile phone, or other electric devices. Otherwise, the device, TV, or radio may generate noise.
- Do not expose the device to excessive dust or vibration, or extreme cold or heat (such as in direct sunlight, near a heater, or in a car during the day), in order to prevent the possibility of panel disfiguration, unstable operation, or damage to the internal components.
- Do not place vinyl, plastic or rubber objects on the device, since this might discolor the panel.
- When cleaning the device, use a dry and soft cloth. Do not use paint thinners, solvents, cleaning fluids, or chemical-impregnated wiping cloths.
- Condensation can occur in the device due to rapid, drastic changes in ambient temperature—when the device is moved from one location to another, or air conditioning is turned on or off, for example. Using the device while condensation is present can cause damage. If there is reason to believe that condensation might have occurred, leave the device for several hours without turning on the power until the condensation has completely dried out.
- To avoid generating unwanted noise, make sure there is adequate distance (50cm or more) between the AC adaptor and the device.
- Do not apply oil, grease, or contact cleaner to the knobs. Doing so may cause problems with electrical contact or knob motion.
- Always turn the power off when the device is not in use.
- Even when the power switch is in standby status, electricity is still flowing to the device at the minimum level. When you are not using the device for a long time, make sure you unplug the power cord from the wall AC outlet.

■ Connectors

XLR-type connectors are wired as follows (IEC60268 standard): pin 1: ground, pin 2: hot (+), and pin 3: cold (-).

Information

■ About copyrights

- Copying of the software or reproduction of this manual in whole or in part by any means is expressly forbidden without the written consent of the manufacturer.
- This product incorporates and bundles computer programs and contents in which Steinberg Media Technologies GmbH and Yamaha Corporation own copyrights or with respect to which it has license to use others' copyrights. Such copyrighted materials include, without limitation, all computer software, style files, MIDI files, WAVE data, musical scores and sound recordings. Any unauthorized use of such programs and contents outside of personal use is not permitted under relevant laws. Any violation of copyright has legal consequences. **DON'T MAKE, DISTRIBUTE OR USE ILLEGAL COPIES.**

■ About this manual

- The illustrations as shown in this manual are for instructional purposes only.
- Steinberg Media Technologies GmbH and Yamaha Corporation make no representations or warranties with regard to the use of the software and documentation and cannot be held responsible for the results of the use of this manual and the software.
- iPhone and iPad are trademarks of Apple Inc., registered in the U.S. and other countries.
- IOS is a trademark or registered trademark of Cisco in the U.S. and other countries and is used under license.
- Steinberg and Cubase are registered trademarks of Steinberg Media Technologies GmbH.
- The company names and product names in this manual are the trademarks or registered trademarks of their respective companies.
- Software may be revised and updated without prior notice.

■ About disposal

This product contains recyclable components. When disposing of this product, please contact the appropriate local authorities.

European models

Purchaser/User Information specified in EN55103-2:2009.

Conforms to Environments: E1, E2, E3 and E4

The model number, serial number, power requirements, etc., may be found on or near the name plate, which is at the bottom of the unit. You should note this serial number in the space provided below and retain this manual as a permanent record of your purchase to aid identification in the event of theft.

Model No.

Serial No.

(bottom_en_01)

OBSERVERA!

Apparaten kopplas inte ur växelströmskällan (nätet) så länge som den är ansluten till vägguttaget, även om själva apparaten har stängts av.

ADVARSEL: Netspændingen til dette apparat er IKKE afbrudt, så længe netledningen sidder i en stikkontakt, som er tændt — også selvom der er slukket på apparatets afbryder.

VAROITUS: Laitteen toisiopiiriin kytketty käyttökytin ei irroita koko laitetta verkosta.

(standby)

이 기기는 가정용 (B 급) 전자파적합기기로서 주로 가정에서 사용하는 것을 목적으로 하며, 모든 지역에서 사용할 수 있습니다.

(class b korea)

Thank you and congratulations on your purchase of the Yamaha MG12XUK mixing console. This product is a mixing console for adjusting the balance of multiple sound sources. This manual explains, for users who may not be familiar with mixers, how to mix multiple sound sources during live performances by a band or in other events. Please read this manual thoroughly to get the most out of the product and ensure long-term, trouble-free use. After reading this manual, please keep it available for future reference.

Contents

PRECAUTIONS	4	Technical Specifications	21
Contents	7	General Specifications	21
Main Features	8	Analog Input Characteristics	22
Quick Start Guide	9	Analog Output Characteristics	22
STEP 1 Connecting external devices, such as		Digital Input / Output Characteristics	22
speakers, microphones and instruments	9	Jack and Connector List	23
STEP 2 Getting sound to the speakers	10	Connector Types	23
Controls and Functions	12	Block and Level Diagrams	24
Top panel		Dimensions	25
Channel section	12		
Master section	14		
Internal effect section	15		
Rear panel			
USB section	16		
Applying Effects	17		
Troubleshooting	18		
When No Sound Is Output	18		
Other	20		

Main Features

D-PRE and High-Quality Operational Amplifiers

Mono input channels are equipped with “D-PRE” Class-A discrete microphone preamplifiers. The D-PRE head amplifier features an inverted Darlington circuit used in high-end audio devices. This circuit uses multi-stage amplifying elements to ensure high current and low impedance, for an audio texture with crispness and richness in the low and mid frequencies. Combined with the specially-designed “MG01” operational amp, the overall result is full-bodied reproduction of low frequencies as well as sustained high frequencies. Input channels feature combo jacks, which can accept both XLR and TRS connectors. In addition, PAD circuitry allows line level input, to accommodate a wide variety of instruments.

24 High-Quality Digital Effects

MG12XUK features 24 built-in effects that are based on SPX algorithms used by professionals. In particular, the high-quality reverb and delay expand the spatial quality of the sound with remarkable realism and naturalness.

24-bit/192 kHz USB Audio Interface

MG12XUK features a USB 2.0 audio interface capable of 24-bit/192 kHz sound quality. With the audio interface you can play back music from your computer, or use DAW software such as Cubase AI to record the mixer output. The XU models support USB Audio Class 2.0 so you can use them with USB Audio Class 2.0 compliant tablets and other devices, without the need to install drivers. The USB protocol uses asynchronous data transfer. Audio data is transferred based on a highly precise audio clock signal from the MG, for high quality recording and playback.

MG Rec & Play

The MG Rec & Play software application enables recording to an iPhone/iPad connected to MG12XUK, as well as playback of songs and sounds from an iPhone/iPad. This application can be used for a wide range of purposes, such as recording live gigs, providing background music for entertainment events, or sound effects for parties.

NOTE

iOS applications may not be supported in your area. Please check with your Yamaha dealer.

Cubase AI, Cubasis LE

The MG12XUK comes with the Steinberg DAW software “Cubase AI” and supports the DAW software “Cubasis LE” for iPad.

NOTE

For details on MG Rec & Play, Cubase AI, and Cubasis LE, visit the Yamaha website at:
http://www.yamahaproaudio.com/mg_xu

Accessories (Please check that they are included with your mixing console.)

- AC Adaptor
- Cubase AI Download Information
- Owner’s Manual (this book)

Quick Start Guide

STEP 1 Connecting external devices, such as speakers, microphones and instruments

1. Make sure that all devices to be connected to the unit are turned off.
2. Connect speakers, microphones and instruments referring to the connection example below.

Connection Example

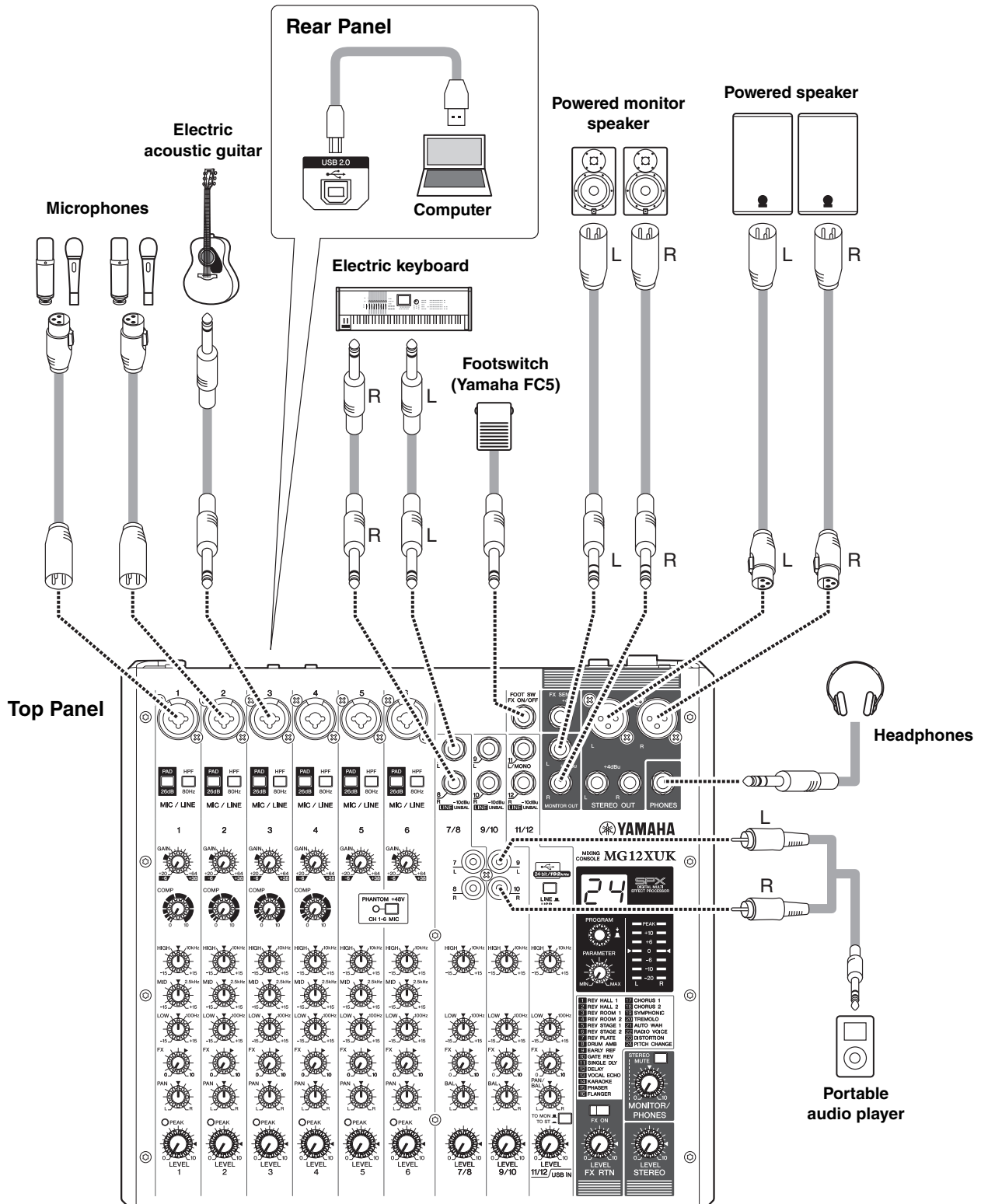

STEP 2 Getting sound to the speakers

1. Make sure that the [⏻ / |] switch at the rear panel is set to the [⏻] position (power off).

2. Connect the supplied AC adaptor.

① Connect the power adaptor with the gap of the plug facing up, aligning it to the [AC ADAPTOR IN] connector.

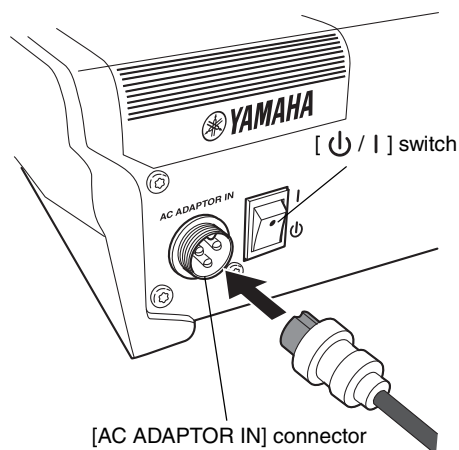

② Turn the fastening ring clockwise to secure the connection.

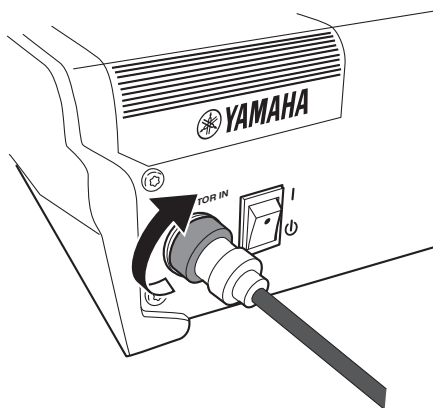

③ Plug the power adaptor into a standard household power outlet.

3. Make sure that all switches on the unit are not engaged (pressed in).

4. Turn all the level control knobs fully to the left (minimum). These include the [GAIN] knobs (white), [LEVEL] knobs (white), and [STEREO LEVEL] knob (red).

5. Set the equalizer knobs (green) to the center “▼” position.

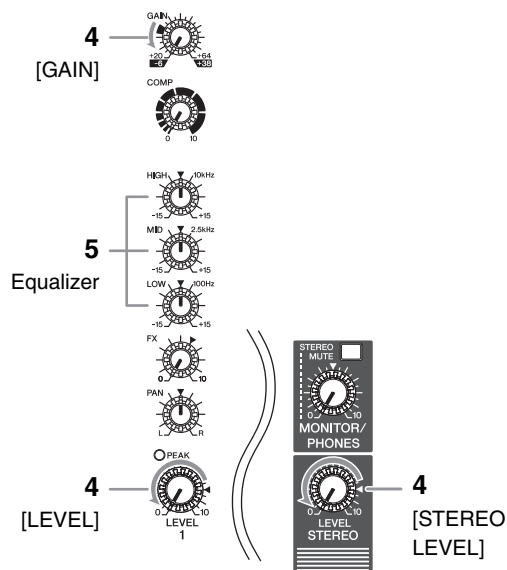

6. If you connect a device with high output level, such as a CD player or an electric keyboard, to one of the channels 1 to 6, turn on (▲) the [PAD] switch of the corresponding channel*.

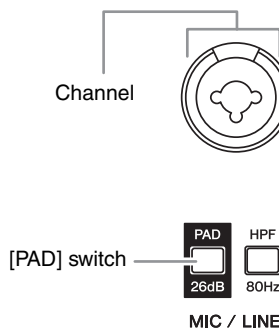





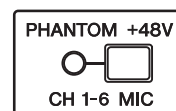

NOTE

If you are using condenser microphones, turn on (▲) the [PHANTOM +48V] switch.



7. Make sure that the volume of a powered speaker or amplifier is set to the minimum.

8. Turn on the power to the connected devices in the following order:  (microphone),  (instrument),  (audio device) ⇒ [ / ] (this unit) ⇒  (speakers).

NOTICE

Follow this order to prevent any loud, unexpected noise from the speakers. Reverse the order when turning the power off.

9. Set the [STEREO LEVEL] knob to the “◀” position.



10. For channels to which a microphone is connected, set the [GAIN] knob to roughly the 12 o'clock position.

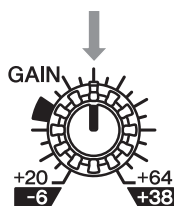

11. Set the [LEVEL] knob of each channel in use to the “◀” position.

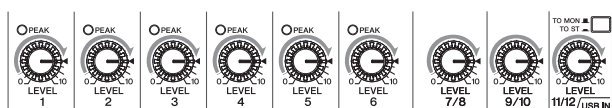

12. While playing your instrument or speaking into the microphone, raise the volume of the powered speaker or amplifier until the desired volume is reached.

NOTE

If the sound is not heard or the sound is distorted, follow the instructions on page 18.

13. Set the [LEVEL] knobs as necessary to adjust the volume balance between the corresponding channels.

This completes the STEP 2 instructions.

NOTE

The volume can be adjusted by using three functions; [PAD], [GAIN], and [LEVEL]. Once you set the [PAD] switch and the [GAIN] knob, avoid adjusting those controls as much as possible. Instead normally use the [LEVEL] knob to adjust the volume. For details about each function, see the “Controls and Functions” section.

Controls and Functions

Top panel

Channel section (Input: ① to ⑭)

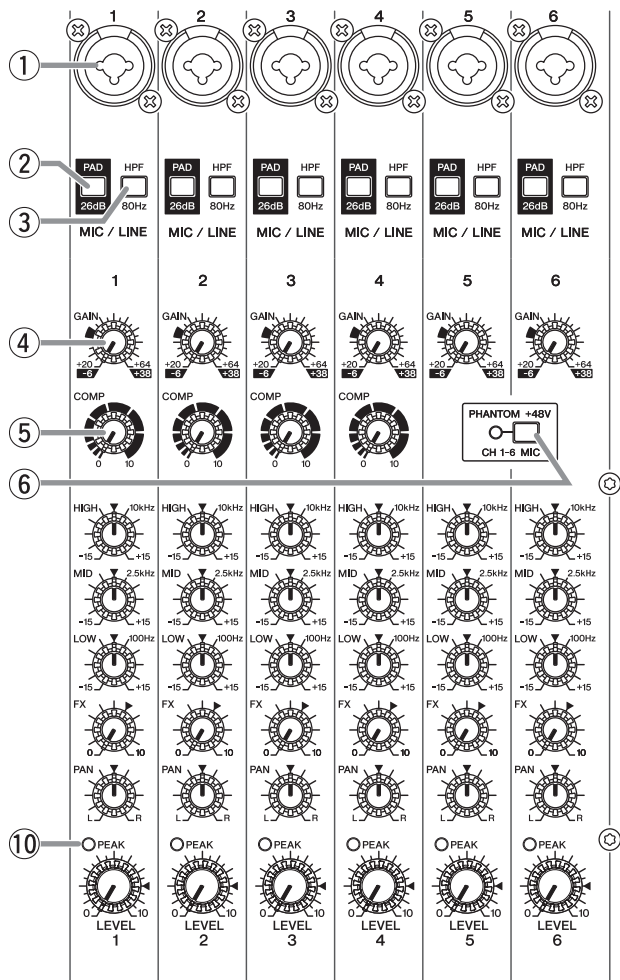

① [MIC/LINE] mono input jacks (channels 1-6)

For connecting a microphone, instrument, or audio device (CD player, etc.) to the unit. These jacks support both XLR and phone plugs.

② [PAD] switches

Turning the switch on () will attenuate the sound input to the unit. If you hear distortion or the [PEAK] LED ⑩ lights, turn the switch on (), in order to reduce unwanted vibration and wind sound received by the microphone.

NOTE

Turn the [LEVEL] knob to "0" (minimum) before toggling the [PAD] switch on () and off (). Otherwise, noise may be produced.

③ [HPF] (High-Pass Filter) switches

Turning the switch on () will apply a high-pass filter that attenuates frequencies below 80 Hz. When speaking into the microphone, you may want to turn this switch on (), in order to reduce unwanted vibration and wind sound received by the microphone.

④ [GAIN] knobs

Determines the basic volume for each of the channels 1 to 6. Adjust these so that the corresponding [PEAK] LEDs ⑩ flash briefly when singing or playing the loudest.

⑤ [COMP] knobs

Adjusts the amount of compression applied to the channel. As the knob is turned to the right, the threshold, the ratio, and the output level are adjusted at the same time.

- Threshold: +22 dBu to -8 dBu
- Ratio: 1:1 to 4:1
- Output level: 0 dB to +7 dB
- Attack time: approx. 25 msec
- Release time: approx. 300 msec

⑥ [PHANTOM +48V] switch/LED

When this switch is on (), the LED lights indicating that the unit supplies DC+48 V phantom power to the XLR plugs of the [MIC/LINE] mono input jacks ①. Turn this switch on when using a phantom-powered condenser microphone.

NOTICE

Be sure to leave this switch off () if you do not need phantom power. Follow the important precautions below, in order to prevent noise and possible damage to external devices as well as the unit when you operate this switch.

- Be sure to leave this switch off when connecting a microphone or other device that does not require phantom power to channels 1 to 6.
- Do not connect/disconnect a cable to/from channels 1 to 6 while this switch is on.
- Turn the [LEVEL] knobs of channels 1 to 6 to the minimum before operating this switch.

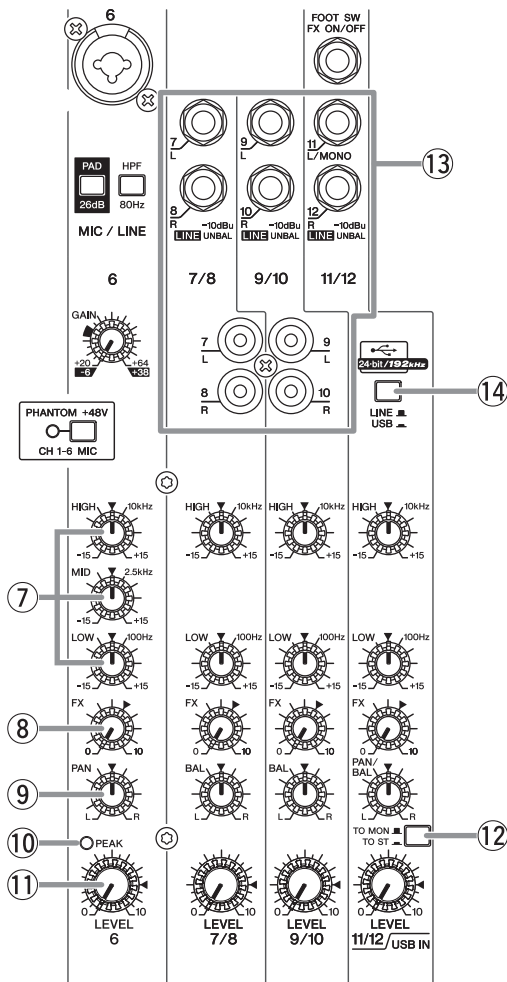

7 Equalizer (EQ) knobs

Adjust the sound quality by using the [HIGH] (high frequency band), [MID] (middle frequency band), and [LOW] (low frequency band) knobs. If you do not need to adjust the sound quality, set the knob to the “▼” (flat) position.

8 [FX] (effect) knobs

Adjusts the volume sent from each channel to the internal effect and the [FX SEND] jack.

**9 [PAN] knobs (channels 1 to 6)
[BAL] knobs (channels 7/8 and 9/10)
[PAN/BAL] knobs (channels 11/12)**

[PAN]: Adjusts the volume balance of each channel sent to the stereo bus, and determines the positioning of the sound image between left and right (stereo L/R). When the knob is located at the 12 o'clock position, the channel's sound will be sent to the stereo bus channels (L and R) at the same volume. In this case, the sound image is positioned at the center.

[BAL]: Determines the volume balance of the stereo channels (7/8 to 11/12) (L/R) sent to the stereo bus. When the knob is located at the 12 o'clock position, the sound of the stereo channels will be sent to the stereo bus channels (L and R) at the same volume respectively.

[PAN/BAL]: Provides both [PAN] and [BAL] functions. You can use this as a [PAN] control when sound is input to the [LINE] (L/MONO) jack, and as a [BAL] control when sound is input to both [LINE] (L) and [LINE] (R) jacks.

10 [PEAK]LED

Lights when the volume of input and/or post-equalizer sound is too high (when reaching 3 dB below clipping). If it is lit frequently, turn the [GAIN] knob ④ to the left to lower the volume.

11 [LEVEL] knobs

For adjusting the volume balance among the channels. Generally, set this to the “◀” position.

12 [TO MON ■/TO ST ■]switch

For selecting the output destination of the input sound to channels 11/12. Normally set this switch to [TO ST ■]. When you use the unit with a computer connected to the [USB 2.0] terminal, toggle this switch according to your specific application, referring to the chart in “Rear panel USB section.”

13 [LINE] stereo input jacks (channels 7/8 to 11/12)

For connecting line-level devices such as an electric keyboard or an audio device. These jacks support phone plugs and RCA-pin plugs.

NOTE

Regarding input to channels 7/8 and 9/10, if both phone and RCA-pin jacks are used at the same time, the phone jack will take priority.

14 [LINE ■/USB ■] switch

Toggles the sound source input to channels 11/12. When the switch is set to [LINE ■], the source will be the [LINE] stereo input jack ⑬, and when set to [USB ■], the source will be the [USB 2.0] terminal.

Top panel Master section (Output: 15 to 23)

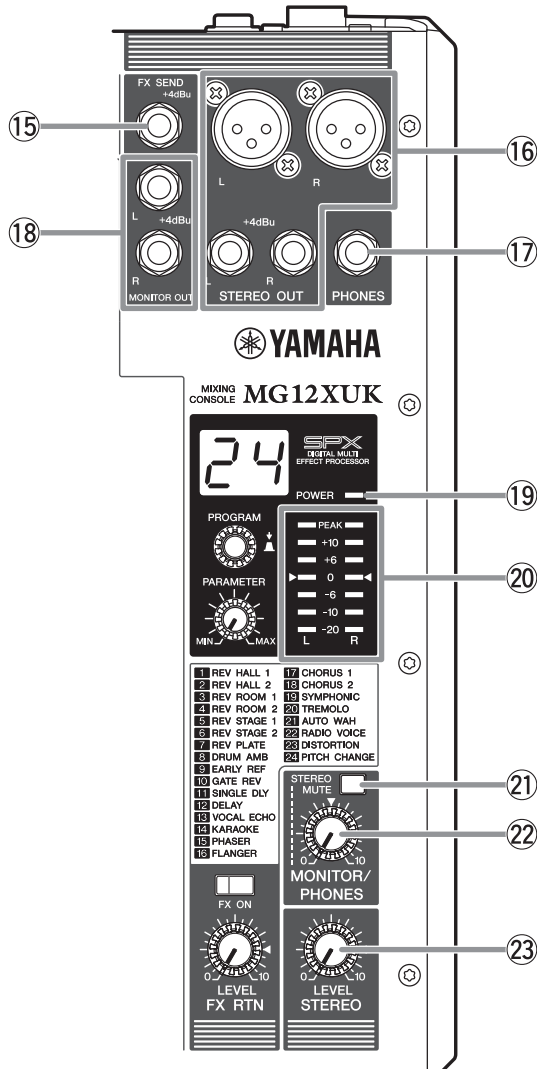

15 [FX SEND] jack

For connecting an external effects unit or a monitor system for players. This phone-plug jack outputs the sound adjusted with the [FX] knob respectively.

16 [STEREO OUT] jacks

For connecting a powered speaker or amplifier. These jacks support both XLR and phone plugs.

17 [PHONES] output jack

For connecting a set of headphones. This jack supports a stereo phone plug.

18 [MONITOR OUT] jacks

For connecting a monitor system for operators. These jacks support phone plugs.

19 [POWER] LED

Lights when the [] switch on the rear panel is set to on (pressed to the [] position).

20 Level meter

The L and R meters show the level (volume) of the signal output from the [STEREO OUT] jacks by seven steps; "PEAK" (+17), "+10", "+6", "0", "-6", "-10", and "-20" dB. If the "PEAK" lamp continuously lights in red, turn the [STEREO LEVEL] knob to the left to lower the volume.

21 [STEREO MUTE] switch

Turning the switch on () will mute the sound of stereo bus from the output of [MONITOR OUT] jacks or [PHONES] jack. In this state, when setting the [TO MON]/TO ST] switch 12 for channels 11/12 to [TO MON], you can hear the sound only from channels 11/12. For details about the switch, see the "Rear panel USB section" on page 16.

22 [MONITOR/PHONES] knob

Adjusts the volume output to the [MONITOR OUT] jacks and the [PHONES] jack.

23 [STEREO LEVEL] knob

Adjusts the overall volume output from the [STEREO OUT] jacks.

Top panel

Internal effect section (Output: ① to ⑦)

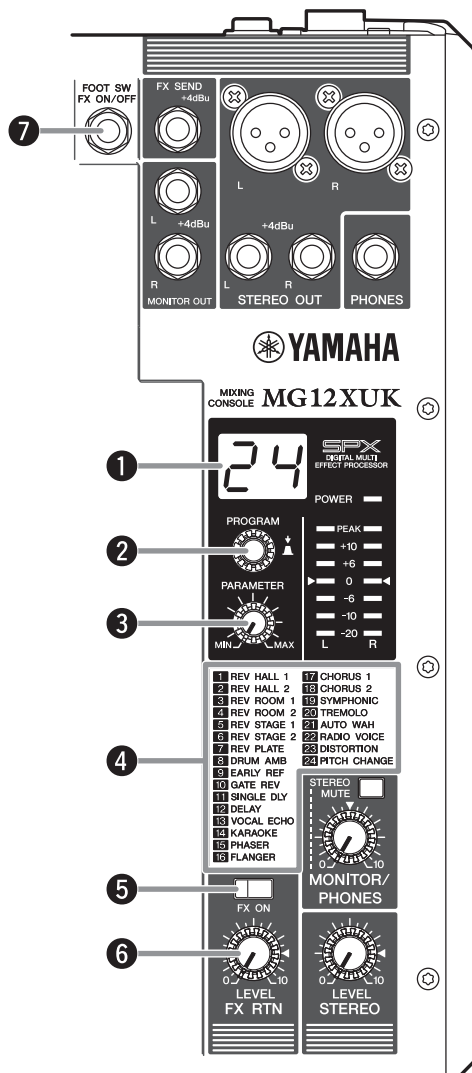

① Display

Indicates the effect program number selected with the [PROGRAM] knob ②. The number flashes during selection; however, if several seconds pass without a selection being made, the program returns to the last number selected.

② [PROGRAM] knob

Selects one of the 24 internal effects from 1-24. Turn the knob to select the desired effect program, and then press the knob to actually set it. For instructions on how to apply the effect, see the section “Applying Effects” on page 17.

NOTE

Turning the knob while pressing it down also allows you to simultaneously select and set the effect program (without needing to press the knob finally to set it).

③ [PARAMETER] knob

Adjusts the parameter (depth, speed, etc.) for the selected effect. The last value used with each effect program is saved. For details about the parameter, see the “Effect Programs” list on page 17.



NOTE

When you change to a different effect program, the unit automatically restores the value that was previously used with that program (regardless of the current position of the [PARAMETER] knob). Once you turn the [PARAMETER] knob, the value of current knob position will become valid.

④ Effect program list

This is the list of the internal effect programs. For details about the programs, see the “Effect Programs” list on page 17.

⑤ [FX ON] switch

When the switch is turned on (), the switch lights indicating the internal effect is active. If you turn off the internal effect with the foot switch when the switch is on (), the LED of the switch flashes.

⑥ [FX RTN LEVEL] knob

Adjusts the volume of the internal effect sound.

⑦ [FOOT SW] jack

For connecting an optionally available unlatched type footswitch, such as the Yamaha FC5. When the [FX ON] switch ⑤ is turned on (), the internal effects can be toggled on/off with the footswitch as needed with your foot. This jack supports a phone plug.

Rear panel

USB section (24 to 26)

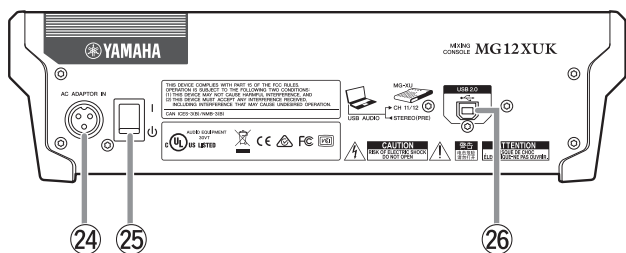

Caution

The unit may heat up by as much as 15 to 20°C while the power is on. This is normal. Please note that since the panel temperature may exceed 50°C in ambient temperatures higher than 30°C, you should exercise caution to prevent burns.

24 [AC ADAPTOR IN] connector

For connecting the supplied AC adaptor.

25 [⏻ / |] switch

For turning the power of the unit to standby (⏻) and on (|). The [POWER] LED 19 on the top panel lights when the switch is set to on (|).

NOTE

Rapidly switching the unit between on and standby in succession can cause it to malfunction. After setting the unit to standby, wait for about six seconds before turning it on again.

NOTICE

Even when the switch is in the standby (⏻) position, electricity is still flowing to the unit. If you do

not plan to use the unit for a while, be sure to unplug the AC adaptor from the outlet.

26 [USB 2.0] terminal

For connecting to a computer via a commercially available USB 2.0 cable. (This product does not come with a cable.) The sound of the stereo bus is output to the computer. (The [STEREO LEVEL] knob 23 does not affect the sound.) For inputs and outputs to/from the computer, you may need a dedicated USB driver. Check and download the driver at the following Yamaha web site and install it to the computer before use. The cable should be no more than 3 meters long.

http://www.yamahaproaudio.com/mg_xu/

■ Using the unit connected to a computer

Set the [LINE ■ / USB ■] switch 14 of channels 11/12 to [USB ■]. Depending on your particular application, you can specify the output destination and monitoring sound by selecting the settings of the [TO MON ■ / TO ST ■] switch 12 for channels 11/12 and the [STEREO MUTE] switch 21. For details, see the chart below.

■ Adjusting the playback volume from a computer (Attenuator)

1. Press the [PROGRAM] knob five times consecutively to display the attenuation value (dB).
2. Turn the [PROGRAM] knob to set it between -24 dB to 0 dB (minus sign is not displayed).
3. Press the [PROGRAM] knob again to exit the setting. When the attenuator is enabled, the dot lights at the lower right of the display.

Output Destinations and Monitoring Sound

Application	Selection of the output destination sent from channels 11/12		Selection of the monitoring sound with the headphones/monitor speaker	
	[TO MON ■ / TO ST ■] switch	Output destination	[STEREO MUTE] switch	Monitoring sound
When recording with DAW software while listening to the playback sound from a computer.	[TO MON ■]*1	[MONITOR OUT] jack*2 [PHONES] jack*2	On (■)	The direct sound (of the instrument) input to the MG12XUK will be muted, allowing you to hear the playback sound only from the DAW. (Direct monitoring: Off)
			Off (■)	You can hear the mixed sound of the direct instrument sound input to the MG12XUK and the playback sound from the DAW. (Direct monitoring: On)
When playing back sound from a computer. For example: BGM playback, Internet broadcasting	[TO ST ■]	Stereo bus → [STEREO OUT] jack	Normally set to Off (■)	You can hear the mixed sound of the instrument sound input to the MG12XUK and the playback sound from a computer.

*1 NOTICE: If you set the switch to [TO ST ■] when you use the DAW software, a loop may be produced, possibly resulting in feedback.

*2 The audio signal cannot be sent to the computer because it does not pass through the stereo bus.

Applying Effects

The MG12XUK features high-quality built-in signal processing effects that are in the same league as our famed SPX effect processor series. Applying effects (as described below) allows you to simulate the acoustics of different performance environments.

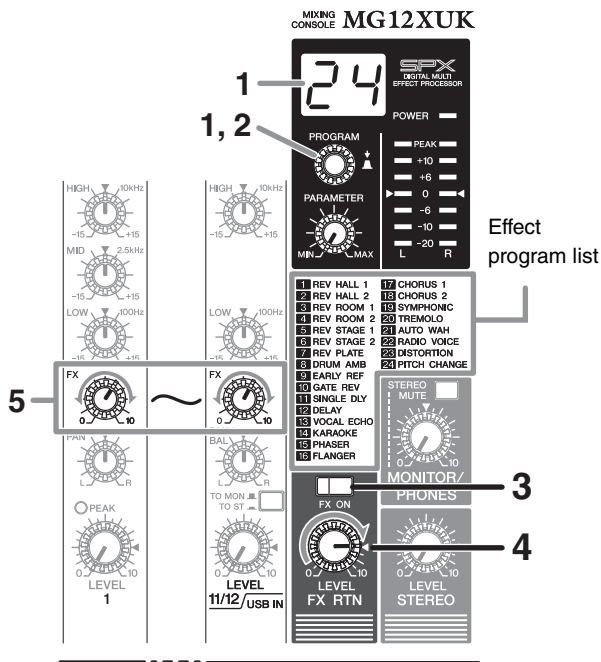

- Turn the [PROGRAM] knob to select a desired effect program number from the effect program list.

The currently selected effect program number flashes on the display.

NOTE
For details about the effect programs, refer to the “Effect Programs” list on the right side.
- Press the [PROGRAM] knob to actually select it.

The desired effect program is selected.
- Turn on () the [FX ON] switch.
- Set the [FX RTN LEVEL] knob to the “◀” position.
- Turn the [FX] knob of the channel to which you want to apply the effect to adjust the effect amount.

Effect Programs

No.	Program	Parameter	Description
1	REV HALL 1	Reverb Time	Reverb simulating a large space such as a concert hall.
2	REV HALL 2	Reverb Time	
3	REV ROOM 1	Reverb Time	Reverb simulating the acoustics of a small space (room).
4	REV ROOM 2	Reverb Time	
5	REV STAGE 1	Reverb Time	Reverb simulating a large stage.
6	REV STAGE 2	Reverb Time	
7	REV PLATE	Reverb Time	Simulation of a metal-plate reverb unit, producing a more hard-edged reverberation.
8	DRUM AMB	Reverb Time	A short reverb that is ideal for use with a drum kit.
9	EARLY REF	Room Size	An effect which isolates only the early reflection components from reverberation, creating a “flashier” effect than conventional reverb.
10	GATE REV	Delay Time	An effect which cuts halfway the tail-end of the reverberation, making a more powerful sound.
11	SINGLE DLY	Delay Time	An effect which repeats the same sound only once. Shortening the delay time produces a doubling effect.
12	DELAY	Delay Time	Feedback delay adding multiple delayed signals.
13	VOCAL ECHO	Delay Time	Echo designed for conventional vocals.
14	KARAOKE	Delay Time	Echo designed for karaoke (sing-along) applications.
15	PHASER	LFO* Freq	Cyclically changes the phase to add modulation to the sound.
16	FLANGER	LFO* Freq	Adds modulation to the sound, producing an effect similar to the rise and fall sound of a jet engine.
17	CHORUS 1	LFO* Freq	Creates a thicker ensemble-like sound by adding the multiple sounds with different delay times.
18	CHORUS 2	LFO* Freq	
19	SYMPHONIC	LFO* Depth	Multiplies the sound for thicker texture.
20	TREMOLO	LFO* Freq	An effect which cyclically modulates the volume.
21	AUTO WAH	LFO* Freq	A wah-wah effect with cyclical filter modulation. The [PARAMETER] knob adjusts the speed of the LFO* that modulates the “wah” filter.
22	RADIO VOICE	Cutoff Offset	Recreates the lo-fi sound of an AM radio. The [PARAMETER] knob adjusts the frequency band to be emphasized.
23	DISTORTION	Drive	Adds a sharp-edged distortion to the sound.
24	PITCH CHANGE	Pitch	An effect which changes the pitch of the signal.

* “LFO” stands for Low Frequency Oscillator. An LFO is normally used to periodically modulate another signal, using different waveform shapes and modulation speeds.

Troubleshooting

When No Sound Is Output

Refer to this section when no sound is output or the volume is very low. This information is for when sound is output from the [STEREO OUT] jacks or the [PHONES] jack.

For details about these functions, see “Controls and Functions” on pages 12 – 16.

STEP 1 Connections and Signal Flow

Check if the instruments, microphones, and speakers are connected correctly, and if any of the cables are damaged.

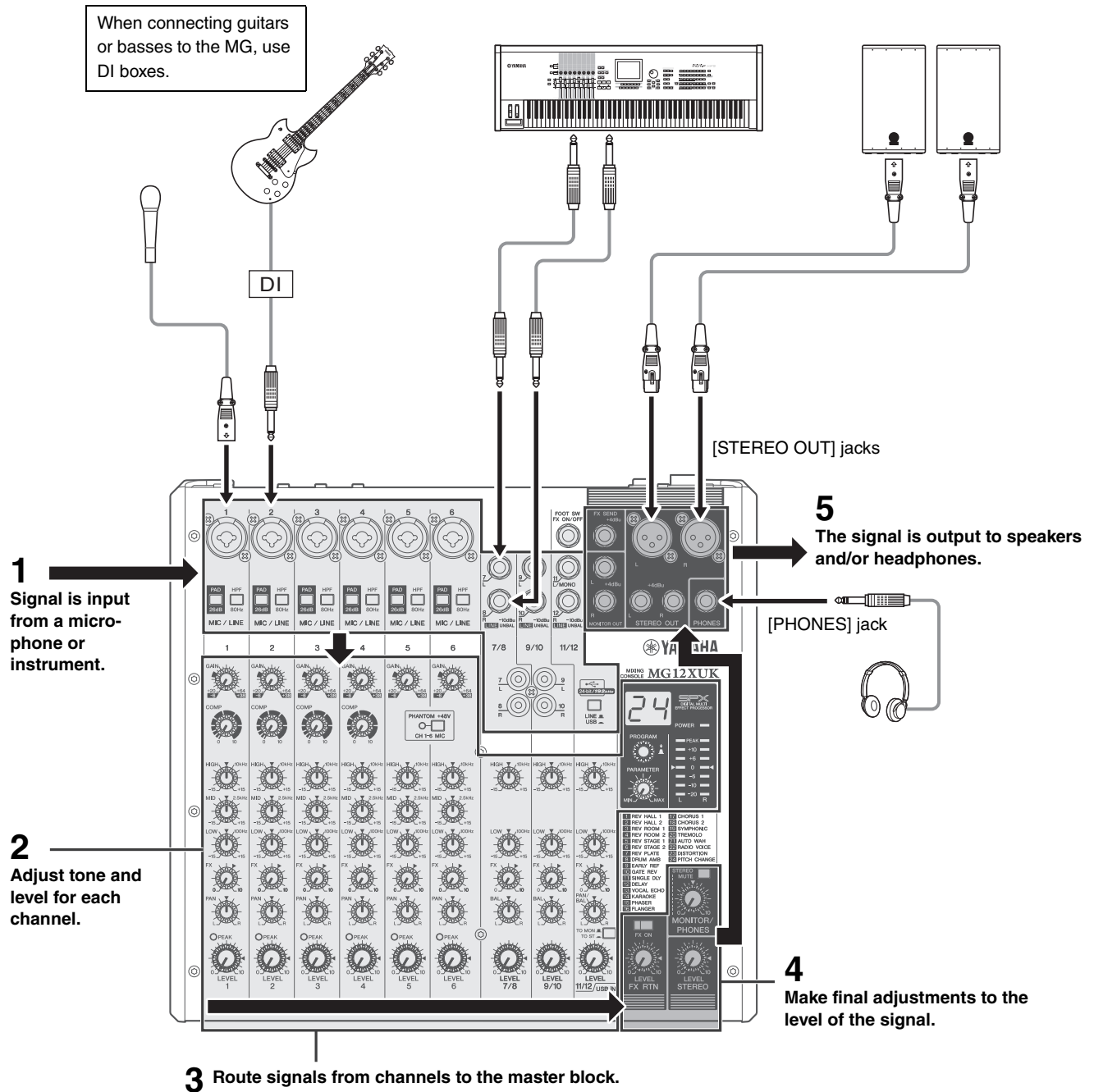

STEP 2 Setting Switches and Controls

● Check the overall balance

Use the settings shown in the illustration to check the overall balance from speakers or headphones.

[GAIN] knobs
Turn until the [PEAK] indicator begins to flash intermittently.

[PHANTOM +48V] switch
Turn this switch on (the indicator lit) when using a condenser microphone.
• To prevent an unwanted burst of noise from the speakers, turn off powered speakers (or power amps) before turning on the [PHANTOM +48V] switch.

[PEAK] indicators

[LEVEL] knobs
For adjusting the level for each channel.



[STEREO LEVEL] knob
For adjusting the overall volume, with “◀” as the nominal level.

[MONITOR/PHONES] knob
For adjusting the headphone level and the MONITOR level.

Level meter
If the level meter [PEAK] indicator flashes frequently, lower the [LEVEL] knobs for each channel.

PEAK

Other

<p>■ The power does not come on.</p>	<p><input type="checkbox"/> Is the mixer connected to an independent power source (generator, etc.) or a power strip with switches? Check that the power of that device is turned on.</p>
<p>■ No sound is output.</p>	<p><input type="checkbox"/> Are external instruments (including microphones) and speakers connected correctly? <input type="checkbox"/> Are your cables shorted? <input type="checkbox"/> Are the [GAIN] knobs for each channel, [LEVEL] knobs, [STEREO LEVEL] knob adjusted to appropriate levels? <input type="checkbox"/> Are the [LINE  /USB ] switch set appropriately?</p>
<p>■ The sound is low, distorted, or noisy.</p>	<p><input type="checkbox"/> Is the microphone connected to a [MIC/LINE] jack? <input type="checkbox"/> When using a condenser microphone, is the [PHANTOM +48V] switch turned on? <input type="checkbox"/> Is the [PAD] switch on? Turn this switch off for sources with low output levels, such as microphones. <input type="checkbox"/> Is the output signal level for the instrument connected to the mixer appropriate? <input type="checkbox"/> When connecting an instrument with an output level of +4 dBu, either turn on the [PAD] switch on a mono input channel or use a stereo input channel. <input type="checkbox"/> Where an input channel provides both a XLR input jack and a phone input jack, or a phone input jack and an RCA pin jack, are there connections made at both jacks? Use only one of these jacks. <input type="checkbox"/> Are the [GAIN] knobs for each channel, [LEVEL] knobs, [STEREO LEVEL] knob adjusted to appropriate levels? <input type="checkbox"/> Are effect or compressor levels too high? Use the [FX] knobs, [FX RTN LEVEL] knob, and [COMP] knobs to lower their levels.</p>
<p>■ Effects are not applied.</p>	<p><input type="checkbox"/> Are the [FX] knobs for each channel adjusted to appropriate levels? <input type="checkbox"/> Is the [FX ON] button for [FX RTN] turned on? <input type="checkbox"/> Are the [PARAMETER] knob and [FX RTN LEVEL] knob adjusted to appropriate levels?</p>
<p>■ Speaking voices are not clear.</p>	<p><input type="checkbox"/> Is the [HPF] switch turned on? <input type="checkbox"/> Is the equalizer ([HIGH]/[MID]/[LOW]) adjusted appropriately?</p>
<p>■ No mixer monitor signal is output.</p>	<p><input type="checkbox"/> Are powered speakers connected to the [MONITOR OUT] jacks? Use the [MONITOR/PHONES] knob to adjust the signal output from the [MONITOR OUT] jacks.</p>
<p>■ Left and right levels are different for a stereo signal input.</p>	<p><input type="checkbox"/> Is [PAN] set to the center? If panned to the center, try reversing the left and right input connections. If, after switching the left and right connections, the side with the low volume level also switches, check the instrument or device that is the source of the signal. <input type="checkbox"/> Are you using the same type of cable to connect both the left and right input signals? Cables with built-in resistors will attenuate the signal.</p>
<p>■ The sound level is unstable and inconsistent.</p>	<p><input type="checkbox"/> Is the compressor level set too high? Use the [COMP] knob to lower the level.</p>
<p>■ The volume of audio play-back from a computer need to be adjusted.</p>	<p><input type="checkbox"/> Use the "Attenuator Function": For details, see page 16.</p>

If any specific problem should persist, please contact your Yamaha dealer.

Technical Specifications

General Specifications

0 dBu = 0.775 Vrms, Output impedance of signal generator (Rs) = 150Ω
All level controls are nominal if not specified.

Frequency Response	Input to STEREO OUT	+0.5 dB/-1.0 dB (20 Hz to 48 kHz) , refer to the nominal output level @ 1 kHz, GAIN knob: Min	
Total harmonic distortion (THD+N)	Input to STEREO OUT	0.02 % @ +14dBu (20 Hz to 20kHz), GAIN knob: Min 0.003 % @ +24dBu (1kHz), GAIN knob: Min	
Hum & Noise *1 (20 Hz to 20 kHz)	Equivalent Input Noise	-128 dBu (Mono Input Channel, Rs: 150Ω, GAIN knob: Max)	
	Residual Output Noise	-102 dBu (STEREO OUT, STEREO LEVEL knob: Min)	
Crosstalk (1 kHz) *2		-83 dB	
Input channels		12 channels: Mono [MIC/LINE]: 6, Stereo[LIN]: 3	
Output channels		STEREO OUT: 2, PHONES: 1, MONITOR OUT: 1, FX SEND: 1	
Bus		Stereo: 1, FX: 1	
Input Channel Function	PAD	CH 1 – CH 6	26 dB
	HPF	CH 1 – CH 6	80 Hz, 12 dB/oct
	COMP	CH 1 – CH 4	1-knob compressor (Gain/Threshold/Ratio) Threshold: +22 dBu to -8 dBu Ratio: 1:1 to 4:1, Output level: 0 dB to 7 dB Attack time: approx. 25 msec Release time: approx. 300 msec
	EQ	CH 1 – CH 6	HIGH: Gain: +15 dB/-15 dB, Frequency: 10 kHz shelving MID: Gain: +15 dB/-15 dB, Frequency: 2.5 kHz peaking LOW: Gain: +15 dB/-15 dB, Frequency: 100 Hz shelving
		CH 7/8 – CH 11/12	HIGH: Gain: +15 dB/-15 dB, Frequency: 10 kHz shelving LOW: Gain: +15 dB/-15 dB, Frequency: 100 Hz shelving
	PEAK LED	CH 1 – CH 6	LED turns on when post EQ signal reaches 3 dB below clipping
Level Meter	Post STEREO LEVEL knob	2x7 -segment LED meter [PEAK, +10, +6, 0, -6, -10, -20 dB]	
Internal Digital Effect	SPX Algorithm	24 programs, PARAMETER control:1, FOOT SW:1 (FX RTN CH on/off)	
USB Audio	2 IN / 2 OUT	USB Audio Class 2.0 compliant Sampling Frequency: Max 192 kHz, Bit Depth: 24-bit	
Phantom Power Voltage		+48 V	
Power Supply adaptor		PA-10 (AC 38 VCT, 0.62A, Cable length = 3.6 m) or equivalent recommended by Yamaha	
Power Consumption		22.9 W	
Dimensions (WxHxD)		315 mm x 91 mm x 297 mm (12.4" x 3.6" x 11.7")	
Net Weight		3.0 kg (6.62 lbs)	
Included Accessory		Owner's Manual, AC Adaptor, Cubase AI Download Information	
Optional Accessory		Foot Switch: FC5	
Operating Temperature		0 to +40°C	

*1 Noise is measured with A-weighting filter.

*2 Crosstalk is measured with 1 kHz band pass filter.

Analog Input Characteristics

0 dBu = 0.775 Vrms

Input Terminals	PAD 26 dB	GAIN Trim Position	Actual Load Impedance	For Use with Nominal	Input Level			Connector
					Sensitivity *1	Nominal	Max. before clip	
MIC/LINE 1 - 6	OFF	+64 dB	3kΩ	50–600Ω Mics/Lines	-72 dBu (0.195 mV)	-60 dBu (0.775 mV)	-40 dBu (7.75 mV)	Combo jack *2 (Balanced)
		+20 dB			-28 dBu (30.9 mV)	-16 dBu (122.8 mV)	+4 dBu (1.228 V)	
	ON	+38 dB			-46 dBu (3.884 mV)	-34 dBu (15.46 mV)	-14 dBu (154.6 mV)	
		-6 dB			-2 dBu (615.6 mV)	+10 dBu (2.451 V)	+30 dBu (24.51 V)	
LINE 7/8, 9/10	—	—	10kΩ	600Ω Lines	-22 dBu (615.6 mV)	-10 dBu (245.1 mV)	+10 dBu (2.451 V)	Phone jack *3 RCA pin (Unbalanced)
LINE 11/12								Phone jack *3 (Unbalanced)

*1 Sensitivity is the lowest level that will produce an output of +4dBu (1.228V) or the nominal output level when the unit is set to maximum gain. (All level controls are maximum position.)

*2 1&Sleeve = GND, 2&Tip = HOT, 3&Ring = COLD

*3 Tip = Signal, Sleeve = GND

Analog Output Characteristics

0 dBu = 0.775 Vrms

Output Terminals	Actual Source Impedance	For Use with Nominal	Output Level		Connector
			Nominal	Max. before Clip	
STEREO OUT [L, R]	75Ω	600Ω Lines	+4 dBu (1.228 V)	+24 dBu (12.28 V)	XLR-3-32 *1 Phone jack *2 (Balanced)
MONITOR OUT [L, R] FX SEND	150Ω	10kΩ Lines	+4 dBu (1.228 V)	+20 dBu (7.750 V)	Phone jack *2 (Impedance Balanced)
PHONES	110Ω	40Ω Phones	3 mW + 3 mW	100 mW + 100 mW	Stereo phone jack

*1 1 = Ground, 2 = Hot, 3 = Cold

*2 Tip = Hot, Ring = Cold, Sleeve = Ground

Digital Input / Output Characteristics

Terminals	Format	Data Length *1	Fs	Connector
USB	USB Audio Class 2.0	16 /24 bit	44.1 kHz, 48 kHz, 88.2 kHz, 96 kHz, 176.4 kHz, 192 kHz	USB Standard-B

*1 Data length is depend on the using audio format. USB Audio Class2.0: 16 / 24-bit, Yamaha Steinberg USB Driver: 24-bit

Jack and Connector List

Jacks and Connectors	Polarities	Configurations
MIC/LINE, STEREO OUT	Pin 1: Ground Pin 2: Hot (+) Pin 3: Cold (-)	<div style="display: flex; justify-content: space-around;"> <div style="text-align: center;"> <p>INPUT</p> </div> <div style="text-align: center;"> <p>OUTPUT</p> </div> </div> <p>XLR Jack</p>
MIC/LINE*, AUX SEND, MONITOR OUT, STEREO OUT	Tip: Hot (+) Ring: Cold (-) Sleeve: Ground	<p>TRS Phone Connector</p>
PHONES	Tip: L Ring: R Sleeve: Ground	
LINE (stereo input channels)	Tip: Hot Sleeve: Ground	<p>TS Phone Connector</p>

These jacks also can be connected with TS phone connectors. If you use TS phone connectors, the connection will be unbalanced.

Connector Types

<p>XLR This 3-pin connector is resistant to externally induced noise, and is used primarily for balanced connections. With properly designed receiving circuitry, cables with this type of connector can also be used for unbalanced signals. XLR type connectors are the standard for microphone connections as well as most professional audio gear.</p>	<p>Male</p> <p>Female</p>
<p>Phone Phone connectors are available in TRS and TS types. TRS types are used for stereo headphone jacks, insert jacks, and also for carrying balanced signals in many cases. TS types are used to carry unbalanced signals -for example, electric guitar cables.</p>	<p>TRS Phone</p> <p>TS Phone</p>
<p>RCA Pin This type of unbalanced connector is most commonly found on home audio and video equipment. RCA type pin jacks are often color coded: white for left audio channel and red for right audio channel, for example.</p>	<p>White</p> <p>Red</p>

Block and Level Diagrams

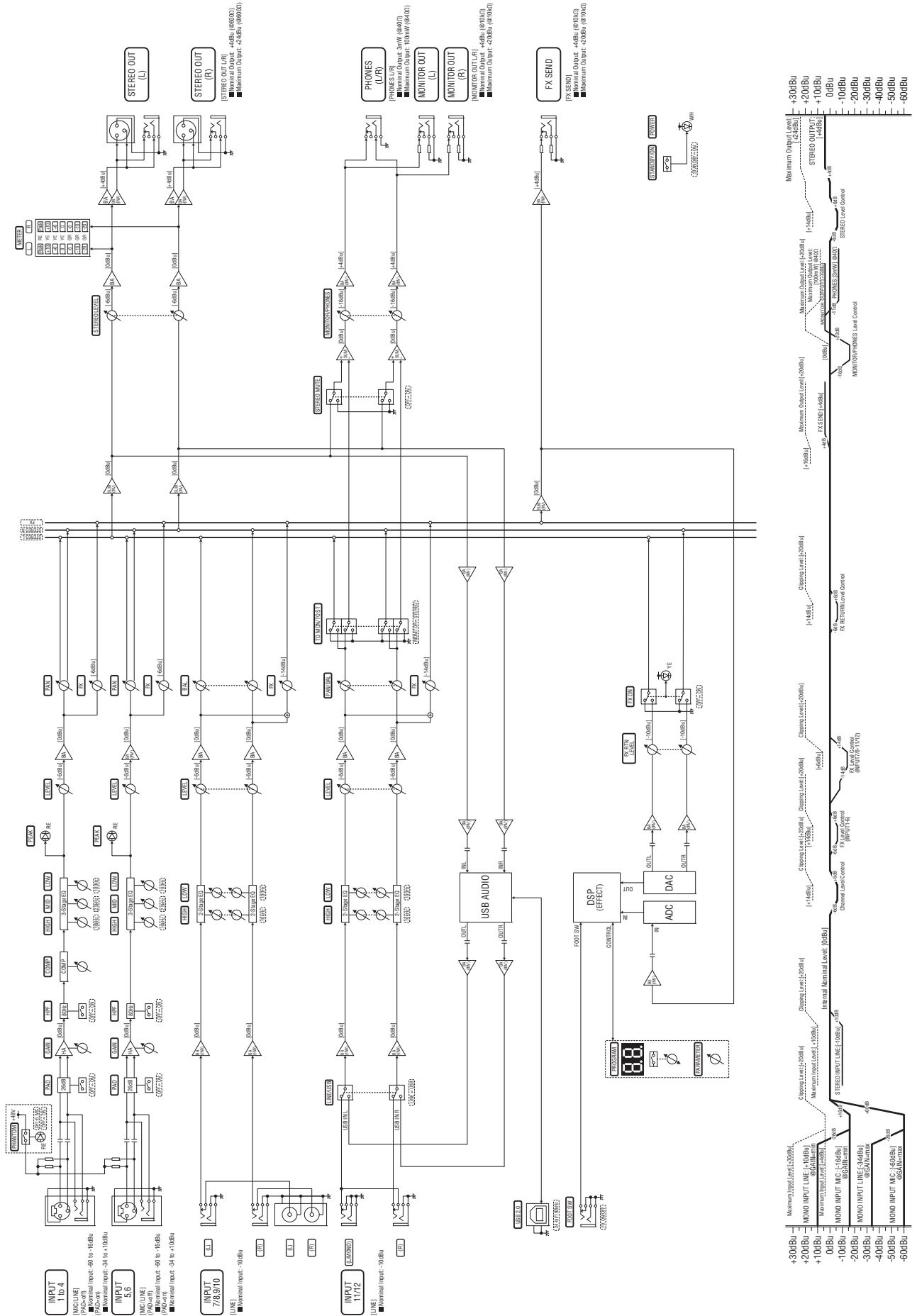

Dimensions

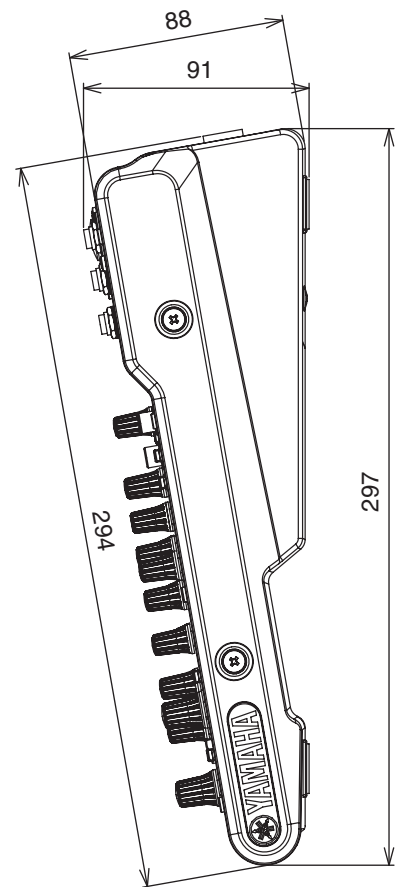
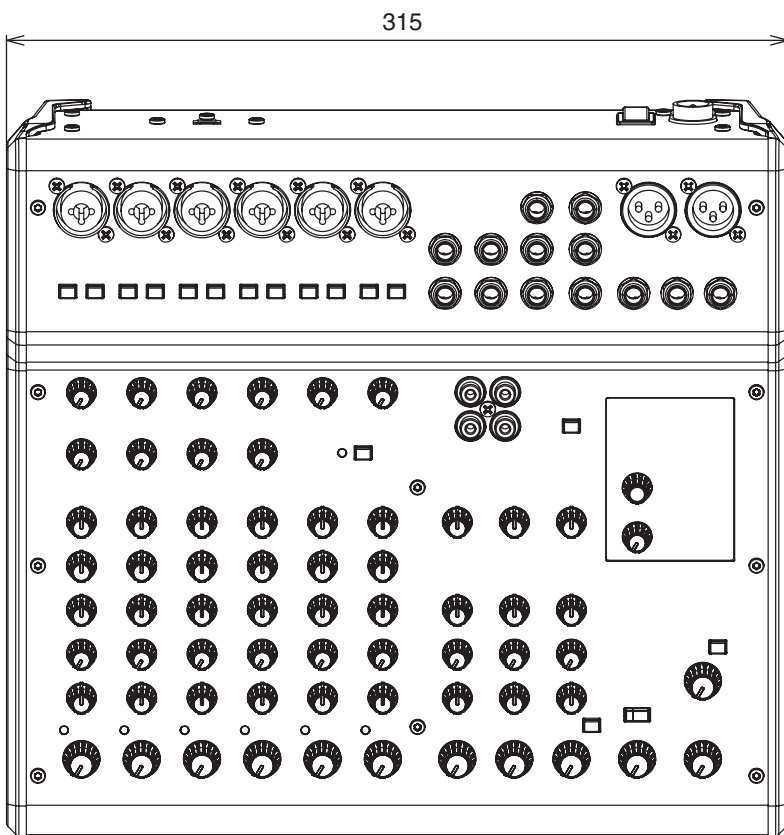
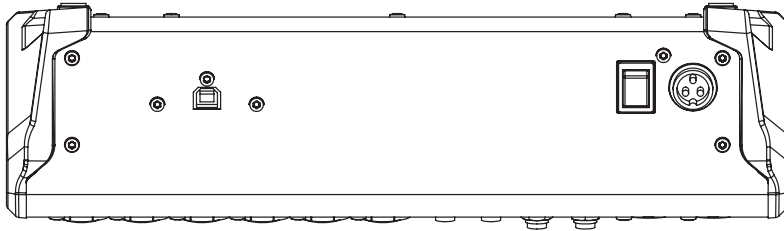

Unit: mm

* The contents of this manual apply to the latest specifications as of the publishing date. To obtain the latest manual, access the Yamaha website then download the manual file.

Important Notice: Guarantee Information for customers in European Economic Area (EEA) and Switzerland

<p>Important Notice: Guarantee Information for customers in EEA* and Switzerland</p> <p>For detailed guarantee information about this Yamaha product, and Pan-EEA* and Switzerland warranty service, please either visit the website address below (Printable file is available at our website) or contact the Yamaha representative office for your country. * EEA: European Economic Area</p>	English
<p>Wichtiger Hinweis: Garantie-Information für Kunden in der EWR* und der Schweiz</p> <p>Für nähere Garantie-Information über dieses Produkt von Yamaha, sowie über den Pan-EWR*- und Schweizer Garantieservice, besuchen Sie bitte entweder die folgend angegebene Internetadresse (eine druckfähige Version befindet sich auch auf unserer Webseite), oder wenden Sie sich an den für Ihr Land zuständigen Yamaha-Vertrieb. *EWR: Europäischer Wirtschaftsraum</p>	Deutsch
<p>Remarque importante: informations de garantie pour les clients de l'EEE et la Suisse</p> <p>Pour des informations plus détaillées sur la garantie de ce produit Yamaha et sur le service de garantie applicable dans l'ensemble de l'EEE ainsi qu'en Suisse, consultez notre site Web à l'adresse ci-dessous (le fichier imprimable est disponible sur notre site Web) ou contactez directement Yamaha dans votre pays de résidence. * EEE : Espace Economique Européen</p>	Français
<p>Belangrijke mededeling: Garantie-informatie voor klanten in de EER* en Zwitserland</p> <p>Voor gedetailleerde garantie-informatie over dit Yamaha-product en de garantieservice in heel de EER* en Zwitserland, gaat u naar de onderstaande website (u vindt een afdrukbaar bestand op onze website) of neemt u contact op met de vertegenwoordiging van Yamaha in uw land. * EER: Europese Economische Ruimte</p>	Nederlands
<p>Aviso importante: información sobre la garantía para los clientes del EEE* y Suiza</p> <p>Para una información detallada sobre este producto Yamaha y sobre el soporte de garantía en la zona EEE* y Suiza, visite la dirección web que se incluye más abajo (la versión del archivo para imprimir esta disponible en nuestro sitio web) o póngase en contacto con el representante de Yamaha en su país. * EEE: Espacio Económico Europeo</p>	Español
<p>Avviso importante: informazioni sulla garanzia per i clienti residenti nell'EEA* e in Svizzera</p> <p>Per informazioni dettagliate sulla garanzia relativa a questo prodotto Yamaha e l'assistenza in garanzia nei paesi EEA* e in Svizzera, potete consultare il sito Web all'indirizzo riportato di seguito (è disponibile il file in formato stampabile) oppure contattare l'ufficio di rappresentanza locale della Yamaha. * EEA: Area Economica Europea</p>	Italiano
<p>Aviso importante: informações sobre as garantias para clientes da AEE* e da Suíça</p> <p>Para obter uma informação pormenorizada sobre este produto da Yamaha e sobre o serviço de garantia na AEE* e na Suíça, visite o site a seguir (o arquivo para impressão está disponível no nosso site) ou entre em contato com o escritório de representação da Yamaha no seu país. * AEE: Área Económica Europeia</p>	Português
<p>Σημαντική σημείωση: Πληροφορίες εγγύησης για τους πελάτες στον ΕΟΧ* και Ελλάδα</p> <p>Για λεπτομερείς πληροφορίες εγγύησης σχετικά με το παρόν προϊόν της Yamaha και την κάλυψη εγγύησης σε όλες τις χώρες του ΕΟΧ και την Ελλάδα, επισκεφτείτε την παρακάτω ιστοσελίδα (Εκτυπωσίμη μορφή είναι διαθέσιμη στην ιστοσελίδα μας) ή απευθυνθείτε στην αντιπροσωπεία της Yamaha στη χώρα σας. * ΕΟΧ: Ευρωπαϊκός Οικονομικός Χώρος</p>	Ελληνικά
<p>Viktigt: Garantiinformation för kunder i EES-området* och Schweiz</p> <p>För detaljerad information om denna Yamaha-produkt samt garantiservice i hela EES-området* och Schweiz kan du antingen besöka nedanstående webbadress (en utskriftsvänlig fil finns på webbplatsen) eller kontakta Yamahas officiella representant i ditt land. * EES: Europeiska Ekonomiska Samarbetsområdet</p>	Svenska
<p>Viktig merknad: Garantiinformasjon for kunder i EØS* og Sveits</p> <p>Detaljert garantiinformasjon om dette Yamaha-produktet og garantiservice for hele EØS-området* og Sveits kan fås enten ved å besøke nettadressen nedenfor (utskriftsversjon finnes på våre nettsider) eller kontakte Yamahas kontoret i landet der du bor. *EØS: Det europeiske økonomiske samarbeidsområdet</p>	Norsk
<p>Vigtig oplysning: Garantioplysninger til kunder i EØ* og Schweiz</p> <p>De kan finde detaljerede garantioplysninger om dette Yamaha-produkt og den fælles garantiserviceordning for EØ* (og Schweiz) ved at besøge det websted, der er angivet nedenfor (der findes en fil, som kan udskrives, på vores websted), eller ved at kontakte Yamahas nationale repræsentationskontor i det land, hvor De bor. * EØ: Det Europæiske Økonomiske Område</p>	Dansk
<p>Tärkeä ilmoitus: Takuutiedot Euroopan talousalueen (ETA)* ja Sveitsin asiakkaille</p> <p>Tämän Yamaha-tuotteen sekä ETA-alueen ja Sveitsin takuuta koskevat yksityiskohtaiset tiedot saatte alla olevasta nettiosoitteesta. (Tulostettava tiedosto saatavissa sivustollamme.) Voitte myös ottaa yhteyttä paikalliseen Yamaha-edustajaan. *ETA: Euroopan talousalue</p>	Suomi
<p>Ważne: Warunki gwarancyjne obowiązujące w EOG* i Szwajcarii</p> <p>Aby dowiedzieć się więcej na temat warunków gwarancyjnych tego produktu firmy Yamaha i serwisu gwarancyjnego w całym EOG* i Szwajcarii, należy odwiedzić wskazaną poniżej stronę internetową (Plik gotowy do wydruku znajduje się na naszej stronie internetowej) lub skontaktować się z przedstawicielstwem firmy Yamaha w swoim kraju. * EOG — Europejski Obszar Gospodarczy</p>	Polski
<p>Důležité oznámení: Záruční informace pro zákazníky v EHS* a ve Švýcarsku</p> <p>Podrobné záruční informace o tomto produktu Yamaha a záručním servisu v celém EHS* a ve Švýcarsku naleznete na níže uvedené webové adrese (soubor k tisku je dostupný na našich webových stránkách) nebo se můžete obrátit na zastoupení firmy Yamaha ve své zemi. * EHS: Evropský hospodářský prostor</p>	Česky
<p>Fontos figyelemztetés: Garancia-információk az EGT* területén és Svájcban élő vásárlók számára</p> <p>A jelen Yamaha termékre vonatkozó részletes garancia-információk, valamint az EGT*-re és Svájcra kiterjedő garanciális szolgáltatás tekintetében keresse fel webhelyünket az alábbi címen (a webhelyen nyomtatható fájl is talál), vagy pedig lépjen kapcsolatba az országában működő Yamaha képviselői irodával. * EGT: Európai Gazdasági Térség</p>	Magyar
<p>Oluline märkus: Garantiiteave Euroopa Majanduspiirkonna (EMP)* ja Šveitsi klientidele</p> <p>Täpsema teabe saamiseks selle Yamaha toote garantii ning kogu Euroopa Majanduspiirkonna ja Šveitsi garantiiteeninduse kohta, külastage palun veebisaiti alljärgnevat aadressil (meie saidil on saadaval printitav fail) või pöörduge Teie regiooni Yamaha esinduse poole. * EMP: Euroopa Majanduspiirkond</p>	Eesti keel
<p>Svarīgs paziņojums: garantijas informācija klientiem EEZ* un Šveicē</p> <p>Lai saņemtu detalizētu garantijas informāciju par šo Yamaha produktu, kā arī garantijas apkalpošanu EEZ* un Šveicē, lūdzam apmeklējiet zemāk norādīto tīmekļa vietnes adresi (tīmekļa vietnē ir pieejams drukājams fails) vai sazinieties ar jūsu valsti apkalpojošo Yamaha pārstāvnīcību. * EEZ: Eiropas Ekonomikas zona</p>	Latviešu
<p>Děmesio: informacija dėl garantijos pirkėjams EEE* ir Šveicarijoje</p> <p>Jei reikia išsamios informacijos apie šį „Yamaha“ produktą ir jo techninę priežiūrą visoje EEE* ir Šveicarijoje, apsilankykite mūsų svetainėje toliau nurodytu adresu (svetainėje yra spausdintinas failas) arba kreipkitės į „Yamaha“ atstovybę savo šalyje. *EEE – Europos ekonominė erdvė</p>	Lietuvių kalba
<p>Dôležité upozornenie: Informácie o záruke pre zákazníkov v EHP* a Švajčiarsku</p> <p>Podrobné informácie o záruke týkajúce sa tohto produktu od spoločnosti Yamaha a garančnom servise v EHP* a Švajčiarsku nájdete na webovej stránke uvedenej nižšie (na našej webovej stránke je k dispozícii súbor na tlač) alebo sa obráťte na zástupcu spoločnosti Yamaha vo svojej krajine. * EHP: Európsky hospodársky priestor</p>	Slovenčina
<p>Pomembno obvestilo: Informacije o garanciji za kupce v EGP* in Švici</p> <p>Za podrobnejše informacije o tem Yamahinem izdelku ter garancijskem servisu v celotnem EGP in Švici, obiščite spletno mesto, ki je navedeno spodaj (natisljiva datoteka je na voljo na našem spletnem mestu), ali se obrnite na Yamahinega predstavnika v svoji državi. * EGP: Evropski gospodarski prostor</p>	Slovenščina
<p>Важно съобщение: Информация за гаранцията за клиенти в ЕИП* и Швейцария</p> <p>За подробна информация за гаранцията за този продукт на Yamaha и гаранционното обслужване в паневропейската зона на ЕИП* и Швейцария или посетете посочения по-долу уеб сайт (на нашия уеб сайт има файл за печат), или се свържете с представителния офис на Yamaha във вашата страна. * ЕИП: Европейско икономическо пространство</p>	Български език
<p>Notificare importantă: Informații despre garanție pentru clienții din SEE* și Elveția</p> <p>Pentru informații detaliate privind acest produs Yamaha și serviciul de garanție Pan-SEE* și Elveția, vizitați site-ul la adresa de mai jos (fișierul imprimabil este disponibil pe site-ul nostru) sau contactați biroul reprezentanței Yamaha din țara dumneavoastră. * SEE: Spațiul Economic European</p>	Limba română

<http://europe.yamaha.com/warranty/>

ADDRESS LIST

NORTH AMERICA

CANADA

Yamaha Canada Music Ltd.
135 Milner Avenue, Toronto, Ontario,
M1S 3R1, Canada
Tel: +1-416-298-1311

U.S.A.

Yamaha Corporation of America
6600 Orangethorpe Avenue, Buena Park, CA 90620,
U.S.A.
Tel: +1-714-522-9011

CENTRAL & SOUTH AMERICA

MEXICO

Yamaha de México, S.A. de C.V.
Av. Insurgentes Sur 1647 Piso 9, Col. San José
Insurgentes, Delegación Benito Juárez, México,
D.F., C.P. 03900, México
Tel: +52-55-5804-0600

BRAZIL

Yamaha Musical do Brasil Ltda.
Rua Fidêncio Ramos, 302 – Cj 52 e 54 – Torre B – Vila
Olimpia – CEP 04551-010 – São Paulo/SP, Brazil
Tel: +55-11-3704-1377

ARGENTINA

**Yamaha Music Latin America, S.A.,
Sucursal Argentina**
Olga Cossetini 1553, Piso 4 Norte,
Madero Este-C1107CEK,
Buenos Aires, Argentina
Tel: +54-11-4119-7000

PANAMA AND OTHER LATIN

AMERICAN COUNTRIES/ CARIBBEAN COUNTRIES

Yamaha Music Latin America, S.A.
Edif. Torre Banco General, Piso 7, Urbanización
Marbella, Calle 47 y Aquilino de la Guardia,
Ciudad de Panamá, República de Panamá
Tel: +507-269-5311

EUROPE

THE UNITED KINGDOM/IRELAND

Yamaha Music Europe GmbH (UK)
Sherbourne Drive, Tilbrook, Milton Keynes,
MK7 8BL, U.K.
Tel: +44-1908-366700

GERMANY

Yamaha Music Europe GmbH
Siemensstrasse 22-34, 25462 Rellingen, Germany
Tel: +49-4101-303-0

SWITZERLAND/LIECHTENSTEIN

**Yamaha Music Europe GmbH, Branch
Switzerland in Thalwil**
Seestrasse 18a, 8800 Thalwil, Switzerland
Tel: +41-44-3878080

AUSTRIA/BULGARIA/ CZECH REPUBLIC/HUNGARY/ ROMANIA/SLOVAKIA/SLOVENIA

**Yamaha Music Europe GmbH
Branch Austria**
Schleiergasse 20, 1100 Wien, Austria
Tel: +43-1-60203900

POLAND

**Yamaha Music Europe GmbH
Sp.z o.o. Oddział w Polsce**
ul. Wielicka 52, 02-657 Warszawa, Poland
Tel: +48-22-880-08-88

MALTA

Olimpus Music Ltd.
Valletta Road, Mosta MST9010, Malta
Tel: +356-2133-2093

NETHERLANDS/BELGIUM/ LUXEMBOURG

Yamaha Music Europe Branch Benelux
Clarissenhof 5b, 4133 AB Vianen, The Netherlands
Tel: +31-347-358040

FRANCE

Yamaha Music Europe
7 rue Ambroise Croizat, Zone d'activités de Pariest,
77183 Croissy-Beaubourg, France
Tel: +33-1-6461-4000

ITALY

Yamaha Music Europe GmbH, Branch Italy
Via Tinelli N.67/69 20855 Gerno di Lesmo (MB),
Italy
Tel: +39-039-9065-1

SPAIN/PORTUGAL

**Yamaha Music Europe GmbH Ibérica, Sucursal
en España**
Ctra. de la Coruña km. 17,200, 28231
Las Rozas de Madrid, Spain
Tel: +34-91-639-88-88

GREECE

Philippos Nakas S.A. The Music House
19th klm. Leof. Lavriou 190 02 Peania – Attiki,
Greece
Tel: +30-210-6686168

SWEDEN/FINLAND/ICELAND

**Yamaha Music Europe GmbH Germany filial
Scandinavia**
JA Wettergrensgata 1, 400 43 Göteborg, Sweden
Tel: +46-31-89-34-00

DENMARK

**Yamaha Music Denmark,
Filial of Yamaha Music Europe GmbH, Tyskland**
Generatorvej 8C, ST. TH. , 2860 Soborg, Denmark
Tel: +45-44-92-49-00

NORWAY

**Yamaha Music Europe GmbH Germany -
Norwegian Branch**
Grini Næringspark 1, 1332 Østerås, Norway
Tel: +47-6716-7800

CYPRUS

Yamaha Music Europe GmbH
Siemensstrasse 22-34, 25462 Rellingen, Germany
Tel: +49-4101-303-0

RUSSIA

Yamaha Music (Russia) LLC.
Room 37, entrance 7, bld. 7, Kievskaya street,
Moscow, 121059, Russia
Tel: +7-495-626-5005

OTHER EUROPEAN COUNTRIES

Yamaha Music Europe GmbH
Siemensstrasse 22-34, 25462 Rellingen, Germany
Tel: +49-4101-3030

AFRICA

Yamaha Music Gulf FZE
JAFZA-16, Office 512, P.O.Box 17328,
Jebel Ali FZE, Dubai, UAE
Tel: +971-4-801-1500

MIDDLE EAST

TURKEY

**Yamaha Music Europe GmbH
Merkezi Almanya Türkiye İstanbul Şubesi**
Maslak Meydan Sodak, Spring Giz Plaza Bagimsiz
Böl. No:3, Sariyer İstanbul, Turkey
Tel: +90-212-999-8010

OTHER COUNTRIES

Yamaha Music Gulf FZE
JAFZA-16, Office 512, P.O.Box 17328,
Jebel Ali FZE, Dubai, UAE
Tel: +971-4-801-1500

ASIA

THE PEOPLE'S REPUBLIC OF CHINA

Yamaha Music & Electronics (China) Co.,Ltd.
2F, Yunhedasha, 1818 Xinzha-lu, Jingan-qu,
Shanghai, China
Tel: +86-400-051-7700

INDIA

Yamaha Music India Private Limited
P-401, JMD Megapolis, Sector-48, Sohna Road,
Gurgaon-122018, Haryana, India
Tel: +91-124-485-3300

INDONESIA

PT. Yamaha Musik Indonesia (Distributor)
Yamaha Music Center Bldg. Jalan Jend. Gatot
Subroto Kav. 4, Jakarta 12930, Indonesia
Tel: +62-21-520-2577

KOREA

Yamaha Music Korea Ltd.
8F, Dongsung Bldg. 21, Teheran-ro 87-gil,
Gangnam-gu, Seoul, 06169, Korea
Tel: +82-2-3467-3300

MALAYSIA

Yamaha Music (Malaysia) Sdn. Bhd.
No.8, Jalan Perbandaran, Kelana Jaya, 47301
Petaling Jaya, Selangor, Malaysia
Tel: +60-3-78030900

SINGAPORE

Yamaha Music (Asia) Private Limited
Block 202 Hougang Street 21, #02-00,
Singapore 530202, Singapore
Tel: +65-6740-9200

TAIWAN

Yamaha Music & Electronics Taiwan Co.,Ltd.
2F., No.1, Yuandong Rd., Banqiao Dist.,
New Taipei City 22063, Taiwan (R.O.C.)
Tel: +886-2-7741-8888

THAILAND

Siam Music Yamaha Co., Ltd.
3, 4, 15, 16th Fl., Siam Motors Building,
891/1 Rama 1 Road, Wangmai,
Pathumwan, Bangkok 10330, Thailand
Tel: +66-2215-2622

VIETNAM

Yamaha Music Vietnam Company Limited
15th Floor, Nam A Bank Tower, 201-203 Cach
Mang Thang Tam St., Ward 4, Dist.3,
Ho Chi Minh City, Vietnam
Tel: +84-8-3818-1122

OTHER ASIAN COUNTRIES

<http://asia.yamaha.com/>

OCEANIA

AUSTRALIA

Yamaha Music Australia Pty. Ltd.
Level 1, 80 Market Street, South Melbourne,
VIC 3205, Australia
Tel: +61-3-9693-5111

COUNTRIES AND TRUST

TERRITORIES IN PACIFIC OCEAN

<http://asia.yamaha.com/>

Yamaha Pro Audio global website:
<http://www.yamaha.com/proaudio/>

Yamaha Downloads:
<http://download.yamaha.com/>

Manual Development Group
© 2018 Yamaha Corporation

Published 01/2018 POEM-A0

ZY29460