

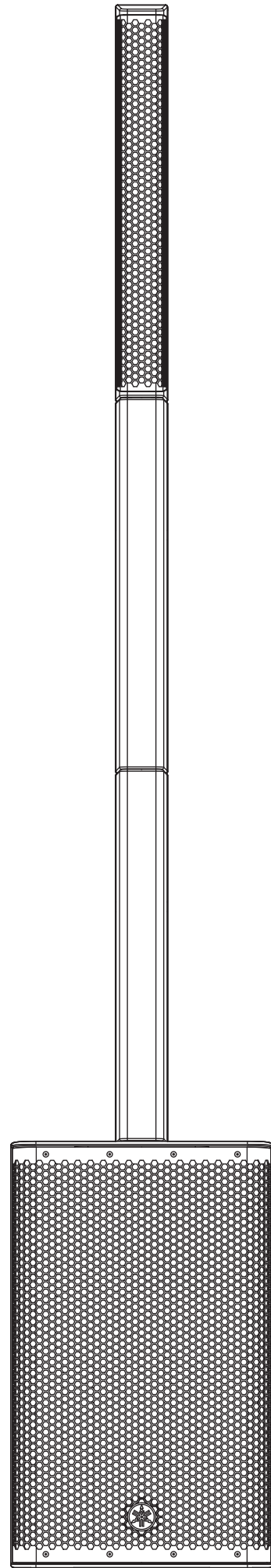

POWERED SPEAKER SYSTEM
SYSTÈME D'ENCEINTES AMPLIFIÉES
SISTEMA DE ALTAVOZ ACTIVO
АКТИВНАЯ АКУСТИЧЕСКАЯ СИСТЕМА
有源音箱
主動式喇叭
앰프내장형 스피커
パワードスピーカーシステム

DXLINK

- EN** Owner's Manual
- DE** Benutzerhandbuch
- FR** Mode d'emploi
- ES** Manual de instrucciones
- PT** Manual do Proprietário
- IT** Manuale di istruzioni
- RU** Руководство пользователя
- ZH-CN** 使用说明书
- ZH-TW** 使用說明書
- KO** 사용설명서
- JA** 取扱説明書



English

Deutsch

Français

Español

Português

Italiano

Русский

简体中文

繁體中文

한국어

日本語

FCC INFORMATION (U.S.A.)

1. IMPORTANT NOTICE: DO NOT MODIFY THIS UNIT!

This product, when installed as indicated in the instructions contained in this manual, meets FCC requirements. Modifications not expressly approved by Yamaha may void your authority, granted by the FCC, to use the product.

2. IMPORTANT: When connecting this product to accessories and/or another product use only high quality shielded cables. Cable/s supplied with this product MUST be used. Follow all installation instructions. Failure to follow instructions could void your FCC authorization to use this product in the USA.

3. NOTE: This product has been tested and found to comply with the requirements listed in FCC Regulations, Part 15 for Class "B" digital devices. Compliance with these requirements provides a reasonable level of assurance that your use of this product in a residential environment will not result in harmful interference with other electronic devices. This equipment generates/uses radio frequencies and, if not installed and used according to the instructions found in the users manual, may cause interference harmful to the operation of other electronic devices. Compliance with FCC regulations does not guarantee that interference will not occur in all installations. If this product is found to be the source of interference, which can be determined by turning the unit "OFF" and "ON", please try to eliminate the problem by using one of the following measures:

- Relocate either this product or the device that is being affected by the interference.
- Utilize power outlets that are on different branch (circuit breaker or fuse) circuits or install AC line filter/s.
- In the case of radio or TV interference, relocate/reorient the antenna. If the antenna lead-in is 300 ohm ribbon lead, change the lead-in to co-axial type cable.

If these corrective measures do not produce satisfactory results, please contact the local retailer authorized to distribute this type of product. If you cannot locate the appropriate retailer, please contact Yamaha Corporation of America, 6600 Orangethorpe Ave., Buena Park, CA90620, USA.

The above statements apply ONLY to those products distributed by Yamaha Corporation of America or its subsidiaries.

(529-M04 FCC class B YCA 01)

COMPLIANCE INFORMATION STATEMENT (Supplier's declaration of conformity procedure)

Responsible Party: Yamaha Corporation of America
Address: 6600 Orangethorpe Ave. Buena Park Calif. 90620
Telephone: 714-522-9011
Type of Equipment: POWERED SPEAKER SYSTEM
Model Name: DXL1K

This device complies with Part 15 of the FCC Rules.

Operation is subject to two following conditions:

- 1) this device may not cause harmful interference, and
- 2) this device must accept any interference received including interference that may cause undesired operation.

(529-M02 FCC sdoc YCA 01)

PRECAUTIONS

PLEASE READ CAREFULLY BEFORE PROCEEDING

Please keep this manual in a safe place for future reference.



WARNING

Always follow the basic precautions listed below to avoid the possibility of serious injury or even death from electrical shock, short-circuiting, damages, fire or other hazards. These precautions include, but are not limited to, the following:

If you notice any abnormality

- If any of the following problems occur, immediately turn off the power switch and disconnect the electric plug from the outlet.
 - The power cord or plug becomes frayed or damaged.
 - Unusual smells or smoke are emitted.
 - Some object, or water has been dropped into the product.
 - There is a sudden loss of sound during use of the product.
 - Cracks or other visible damage appear on the product.
 Then have the product inspected or repaired by qualified Yamaha service personnel.

Power supply

- Do not place the power cord near heat sources such as heaters or radiators, and do not excessively bend or otherwise damage the cord, place heavy objects on it, or place it in a position where anyone could walk on, trip over, or roll anything over it.
- Only use the voltage specified as correct for the product. The required voltage is printed on the name plate of the product.
- Use only the supplied power cord/plug. If you intend to use the product in an area other than in the one you purchased, the included power cord may not be compatible. Please check with your Yamaha dealer.
- Check the electric plug periodically and remove any dirt or dust which may have accumulated on it.
- Make sure to fully insert the electric plug to prevent electric shocks or fire.
- When setting up the product, make sure that the AC outlet you are using is easily accessible. If some trouble or malfunction occurs, immediately turn off the power switch and disconnect the plug from the outlet. Even when the power switch is turned off, as long as the power cord is not unplugged from the wall AC outlet, the product will not be disconnected from the power source.
- Remove the electric plug from the outlet when the product is not to be used for extended periods of time.
- Do not touch the product or the electric plug during an electrical storm.
- Be sure to connect to an appropriate outlet with a protective grounding connection. Improper grounding can result in electrical shock, fire, or damage.

Do not open

- This product contains no user-serviceable parts. Do not attempt to disassemble the internal parts or modify them in any way.

Water warning

- Do not expose the product to rain, use it near water or in damp or wet conditions, or place on it any containers (such as vases, bottles or glasses) containing liquids which might spill into any openings.
- Never insert or remove an electric plug with wet hands.

Fire warning

- Do not place any burning items or open flames near the product, since they may cause a fire.

Hearing loss

- Before turning the power of all devices on or off, make sure that all volume levels are set to the minimum. Failing to do so may result in hearing loss, electric shock, or device damage.
- When turning on the AC power in your audio system, always turn on the product LAST, to avoid hearing loss and speaker damage. When turning the power off, the product should be turned off FIRST for the same reason.



CAUTION

Always follow the basic precautions listed below to avoid the possibility of physical injury to you or others. These precautions include, but are not limited to, the following:

Power supply

- When removing the electric plug from the product or an outlet, always hold the plug itself and not the cord. Pulling by the cord can damage it.

Location and connection

- Do not place the product in an unstable position or a location with excessive vibration, where it might accidentally fall over and cause injury.
- Keep this product out of reach of children. This product is not suitable for use in locations where children are likely to be present.
- Do not block the vents. This product has ventilation holes at the rear to prevent the internal temperature from becoming too high. In particular, do not place the product on its side or upside down. Inadequate ventilation can result in overheating, possibly causing damage to the product(s), or even fire.
- To ensure proper heat dissipation of the product, when installing it:
 - Do not cover it with any cloth.
 - Make sure the top surface faces up; do not install on its sides or upside down.
 - Do not use the product in a confined, poorly-ventilated location.

Inadequate ventilation can result in overheating, possibly causing damage to the product(s), or even fire. Make sure that there is adequate space around the product: at least 30 cm above, 30 cm at the sides and 30 cm behind.

- Do not carry or transport the device unless it is disassembled. Otherwise, you might be injured if the speaker or spacers strike your head or body.
- Do not place the product in a location where it may come into contact with corrosive gases or salt air. Doing so may result in malfunction.
- Before moving the product, remove all connected cables.
- When transporting or moving the product, always use two or more people. Attempting to lift the product by yourself may result in injuries, such as back injuries, or cause the product to be dropped and broken, which could lead to other injuries.
- Do not press the rear panel of the product against the wall. Doing so may cause the plug and speaker cable to come in contact with the wall and detach from the power cord, resulting in short circuiting, malfunction, or even fire.

Maintenance

- Remove the power plug from the AC outlet when cleaning the product.

Handling caution

- Do not insert your fingers or hands in any gaps or openings on the product (vents).
- Do not rest your weight on the product or place heavy objects on it.
- Do not operate the product if the sound is distorting. Prolonged use in this condition could cause overheating and result in fire.
- Do not use the included line array speaker with other products, such as STAGEPAS 1K. Otherwise, malfunction, overheating or fire might be caused.
- Confirm that the finished installation is safe and secure. Also, carry out safety inspections periodically. Failure to observe this may cause devices to fall and result in injury.
- Assemble and install in the manner instructed in the manual. Falling or toppling may result in injury or damage.

IMPORTANT

Please record the serial number of this unit in the space below.

Model

Serial No.

The serial number is located on the bottom or rear of the unit. Retain this Owner's Manual in a safe place for future reference.

* This applies only to products distributed by YAMAHA CORPORATION OF AMERICA.

(Ser.No)

NOTICE

To avoid the possibility of malfunction/ damage to the product, damage to data, or damage to other property, follow the notices below.

Handling and maintenance

- Do not use the product in the vicinity of a TV, radio, or other electric products. Otherwise, the product, TV, or radio may generate noise.
- Do not expose the product to excessive dust or vibration, or extreme cold or heat, in order to prevent the possibility of panel disfiguration, unstable operation, or damage to the internal components.
- Do not install in locations where temperature changes are severe. Otherwise, condensation may form on the inside or the surface of the product, causing it to break.
- If there is reason to believe that condensation might have occurred, leave the product for several hours without turning on the power until the condensation has completely dried out, in order to prevent possible damage.
- Do not place vinyl, plastic or rubber objects on the product, since this might cause alteration or discoloration of the panel.
- Do not use sodium hypochlorite solution, ethanol, benzene, thinner, detergent or a chemical rag to clean the surface of the product. Otherwise, the surface may become discolored or deteriorate.

Information

About functions/data bundled with the product

- XLR-type connectors are wired as follows (IEC60268 standard): pin 1: ground, pin 2: hot (+), and pin 3: cold (-).

About this manual

- The illustrations as shown in this manual are for instructional purposes only.
- The company names and product names in this manual are the trademarks or registered trademarks of their respective companies.

About disposal

- This product contains recyclable components. When disposing of this product, please contact the appropriate local authorities.

Yamaha cannot be held responsible for damage caused by improper use or modifications to the product, or data that is lost or destroyed.

Table of Contents

PRECAUTIONS	4
NOTICE	5
Information.....	5
Introduction.....	7
Features.....	7
Package contents	7
Optional items	7
Controls and Functions.....	8
Top panel	8
Rear panel	9
Quick Start Guide.....	11
Attaching the line array speaker and spacers.....	11
Connecting microphones, musical instruments, or audio devices	11
Getting sound out of the speaker.....	11
Storing the Unit.....	13
Troubleshooting	14
General Specifications	15
Input Characteristics	16
Output Characteristics	16
Dimensions	17
Block Diagram.....	18

Introduction

Thank you for purchasing the Yamaha DXL1K powered speaker! This product is designed for musical events or other live performances. To get the most out of this product and enjoy its sophisticated range of features, we recommend that you read this manual thoroughly and keep it in a safe place for future reference.

Features

- Column-type, 2-way, bi-amplified powered speaker.
- Easy setup involves connecting the line array speaker to the subwoofer.
- Line array speaker can consistently cover a broad area.
- 12-inch subwoofer produces a powerful low range.
- Equipped with a high-efficiency, 1,100 W Class-D amplifier.
- Efficient, dedicated cover that accommodates the line array speaker, spacers, and subwoofer.
- Suitable for a compact PA system that includes a small-size mixing console, such as DM3, TF series, or MG series.
- Combining this product with a STAGEPAS 1K mkII or another DXL1K will upgrade to a stereo or multi-speaker system.

Package contents

- Subwoofer x 1

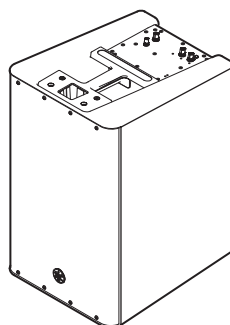

- Dedicated cover x 1

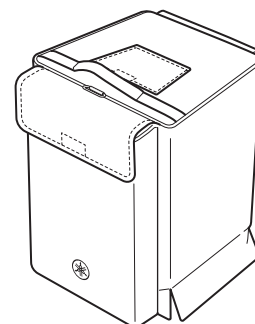

- Line array speaker x 1

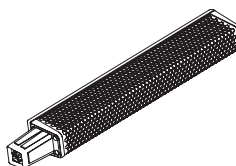

- Spacer x 2

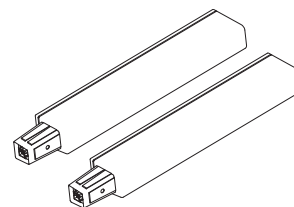

- Power cord x 1

- Owner's Manual (this book)

Optional items

- DL-SP1K (dedicated dolly)

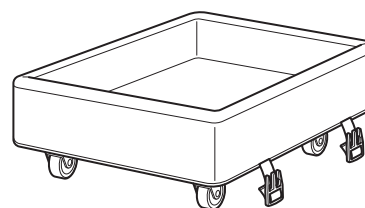

Controls and Functions

Top panel

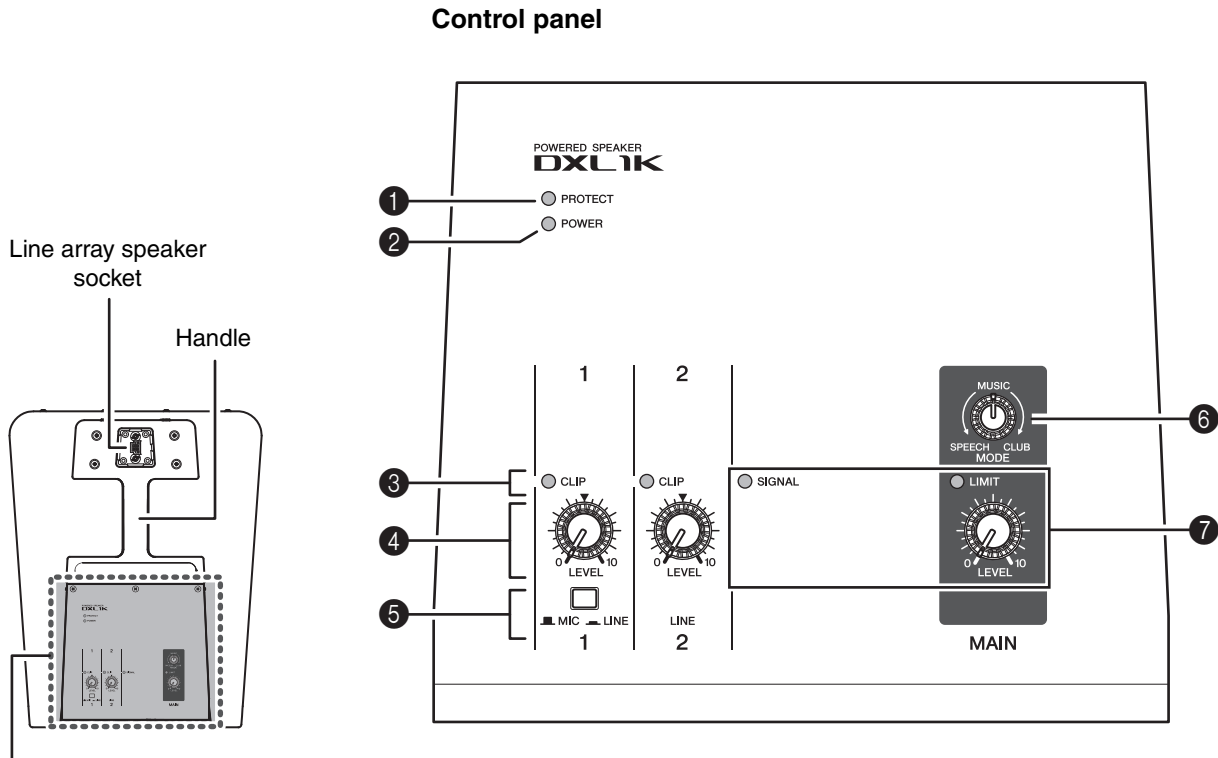

Control panel

1 [PROTECT] LED

Lights red when the protection circuit is activated. The protection circuit will be activated in one of the following cases, and the speaker output will be muted.

- The power to the unit is turned on
When the power is turned on, the protection circuit will be activated for a few seconds to avoid noise. After the unit is fully turned on, the LED will turn off.
- Amplifier overheat is detected
- A current surge is detected

If the protection circuit is activated, wait until the temperature of the amplifier section decreases. Alternatively, turn the power to the unit off and then back on. Then the protection circuit will be deactivated. If the protection circuit is not deactivated, please contact your Yamaha dealer.

2 [POWER] LED

Lights green when the [I/O] (Power) switch (13) is turned on.

3 [CLIP] LEDs

Light red if signals are clipping due to excessive input levels. If these LEDs light up, lower the level of the corresponding input channels, or set the corresponding [MIC/LINE] switches to LINE.

4 [LEVEL] controls

Use these controls to adjust the volume for each channel. To reduce noise, set the LEVEL control on unused channels to minimum.

5 [MIC/LINE] switch (channel 1)

For low-level signals (including microphones), set the switch to the MIC (M) position. For high-level signals (including electronic instruments and audio equipment), set the switch to the LINE (L) position.

6 [MODE] control

Use this control to adjust the overall sound pressure and frequency balance. The center position (MUSIC) is a basic setting. If you turn the control counterclockwise (toward SPEECH), it will cut unneeded low-range frequencies, and create an optimum setting for speech, or singing and playing an acoustic musical instrument. If you turn the control clockwise (toward CLUB), it will boost the high and low ranges, and create an optimum setting for playback of sound sources.

7 [MAIN LEVEL] control/ [LIMIT] LED/[SIGNAL] LED

Determines the volume of the signal output from the speaker and the level of signal routed to the [LINK OUT] jack simultaneously. This allows you to adjust the overall volume without changing the relative volume balance between the channels. The [SIGNAL] LED lights green when the output signal reaches and exceeds a certain level. The [LIMIT] LED lights red when the limiter is applied.

Rear panel

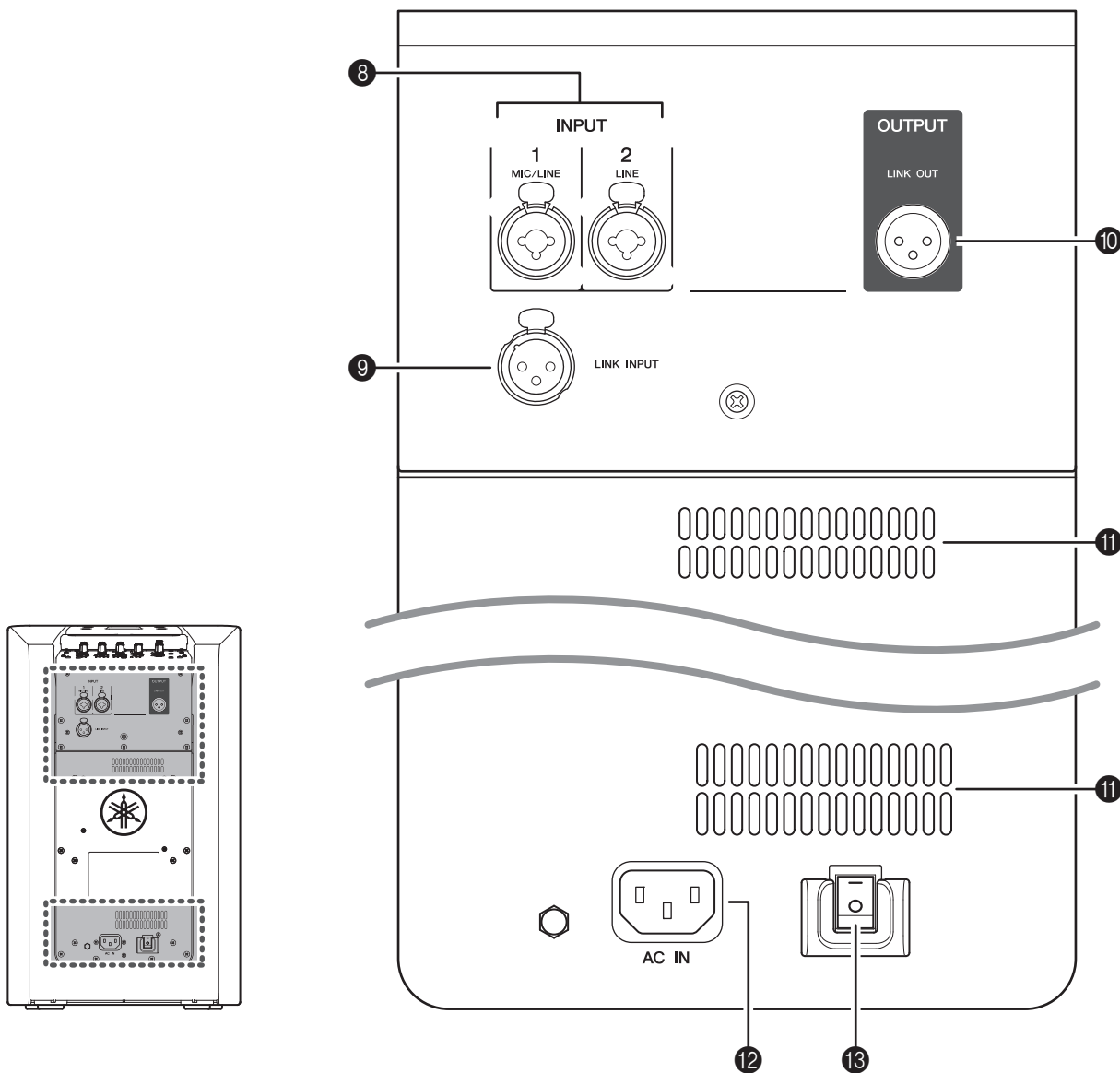

8 Mic/Line input jacks (channels 1-2)
 Connect microphones, guitars, electronic musical instruments or audio equipment. These are combo jacks that support both XLR and phone plugs.

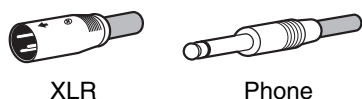

XLR

Phone

9 [LINK INPUT] jack
 This jack supports an XLR-type plug. An input signal is output directly from the speaker. To control the tone and volume level of the signal, use a connected STAGEPAS 1K mkII or mixing console.

10 [LINK OUT] jack
 This jack supports an XLR-type plug. Mixed signals are output to the other DXL1K. Alternatively, you can connect a different powered speaker here.

11 Vents
 These are the vents for the cooling fan inside this product. Do not block the vents when the unit is in use.

12 [AC IN] jack

Connect the included power cord here. Connect the power cord to this jack, and then insert the power plug into an AC outlet.

Be sure to turn off the power switch before connecting or disconnecting the power cord.

13 I / O (Power) switch

Turns the power to the unit on (I) or off (O). When you turn on the power to all connected devices, be sure to first turn on the power to the external sound source, then to this unit, and finally to the device that is connected to the [LINK OUT] jack. When you turn off the power to all devices, follow this order in reverse.

Notice

Even when the power switch is turned off, a minimal amount of electric current is still flowing to the unit. If you plan not to use the unit for an extended period of time, be sure to unplug the power cord from the AC outlet.

NOTE

Rapidly powering the unit on and off in succession may cause it to malfunction. After turning the power off, wait for about five seconds before turning it on again.

Quick Start Guide

Attaching the line array speaker and spacers

Use the included spacers to install the line array speaker at approximately the same height as the ears of the audience. The line array speaker features a grille.

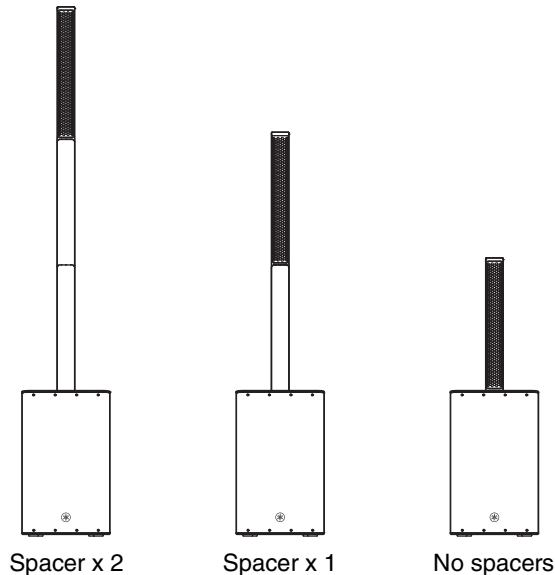

1. Insert the line array speaker and spacers firmly into the sockets one by one.

Use the spacers as needed.

NOTE

Insert the line array speaker and spacers firmly into the sockets. If the connectors are not in contact sufficiently, no sound may be output.



Connecting microphones, musical instruments, or audio devices

Before making connections, lower the volume level to the minimum by rotating the [LEVEL] controls counter-clockwise.

■ Connection example

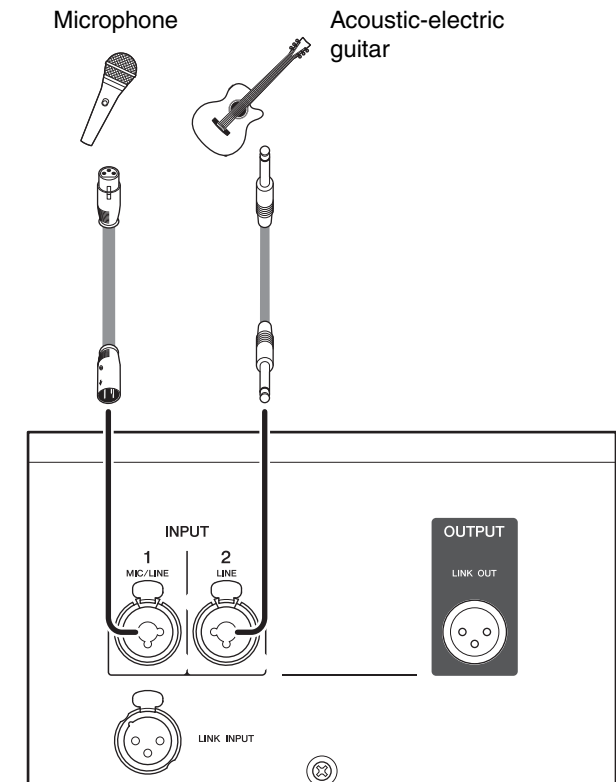

Getting sound out of the speaker

Make sure that the power to the unit is turned off.

2. Connect the plug on the included power cord to the [AC IN] jack on the rear panel of the unit.

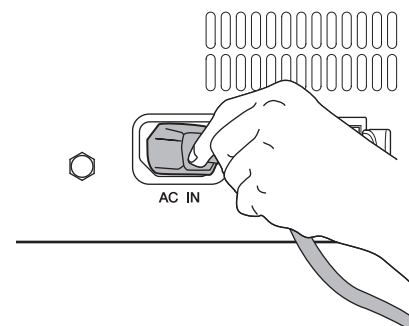

- Insert the other end of the power cord into an AC outlet.



WARNING

- The DXL1K has been designed for grounded use. To avoid electrical shock and damage to connected devices, be sure to ground the unit using the included power cord. If you have any questions regarding proper connections, please contact your nearest Yamaha dealer.
- Use only the included power cord. Otherwise, heat may be generated or an electrical shock may be caused.

Notice

Even when the power switch is turned off, a minimal amount of electric current is still flowing to the unit. If you plan not to use the unit for an extended period of time, be sure to unplug the power cord from the AC outlet.

- Turn the [LEVEL] controls (white knobs) and [MAIN LEVEL] control (red knob) to the minimum (zero).

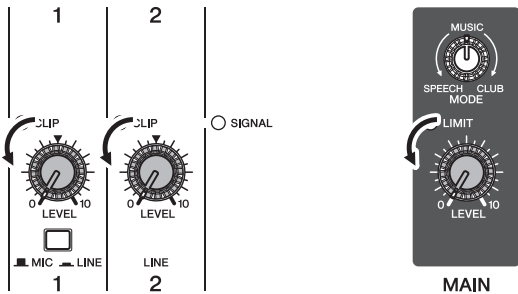

- Set the [MODE] control (yellow knob) to the MUSIC position.

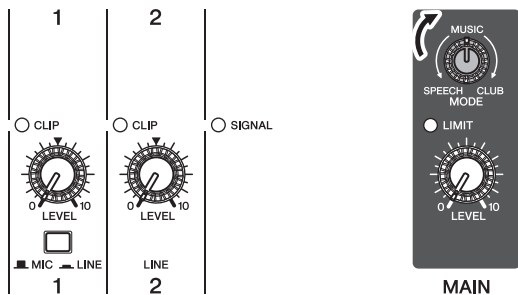

- If a microphone is connected to channel 1, set the [MIC/LINE] switch to the MIC (M) position. If a musical instrument or audio device is connected to channel 1, set the [MIC/LINE] switch to the LINE (L) position.

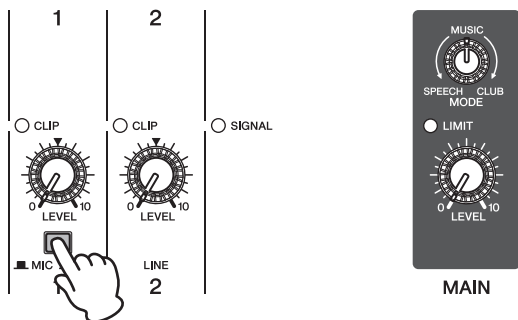

- Turn on the power to the connected musical instrument or audio device first, then turn on the power to this unit.

The [POWER] LED lights up.



- Use the [MAIN LEVEL] control to adjust the volume to an appropriate level.

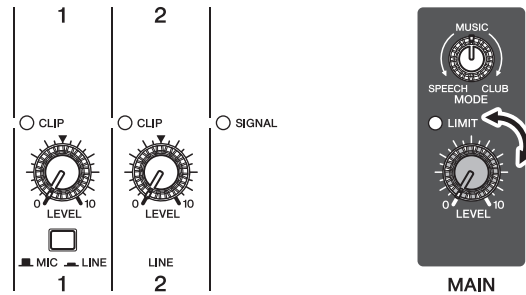

- While playing your musical instrument or singing into the microphone, use the [LEVEL] controls to adjust the volume of the corresponding channels.

- Use the [MAIN LEVEL] control to adjust the overall volume.

If you can hear sound and the volume seems appropriate, setup is complete. If not, please refer to the checklist in the "Troubleshooting" (page 14) section.

NOTE

To avoid any loud, unexpected noises from the speaker, first turn off the power to this unit, and then turn off the connected sound source (such as a musical instrument or audio device).

Adjusting the volume

■ When the volume is too loud

Turn the [LEVEL] control for the corresponding channel to the minimum (zero). Set the [MIC/LINE] switch to the LINE (L) position, then slowly raise the [LEVEL] control until the desired volume is reached.

■ When the volume is too low

Turn the [LEVEL] control for the corresponding channel to the minimum (zero). Set the [MIC/LINE] switch to the MIC (M) position, then slowly raise the [LEVEL] control until the desired volume is reached.

Storing the Unit

1. Install the included, dedicated cover over the DXL1K.

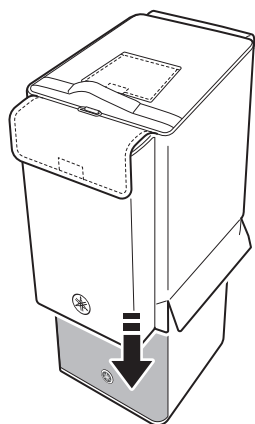

2. Put away the line array speaker and spacers into the pocket that is marked with the Yamaha logo.

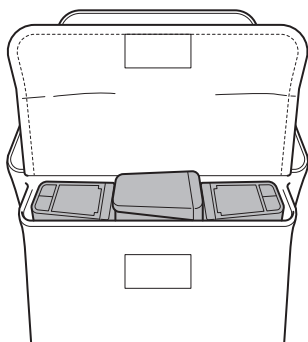

To move the unit, open the flap on top of the cover and hold the handle on the unit.

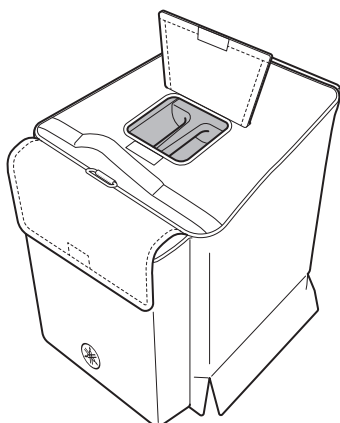

NOTE

For information regarding the DL-SP1K, an optional dolly designed for use with the unit, please refer to the DL-SP1K Owner's Manual.

Troubleshooting

Power does not turn on.

- Did you firmly and securely connect the power cord?

Power shuts down suddenly.

- Are the vents of the unit blocked?
Since inadequate ventilation can result in overheating this product, the power may be turned off automatically to protect the system from overheating. Arrange the ventilation for better cooling, then turn on the power again.

No sound is heard.

- Did you insert the line array speaker and spacers firmly into the sockets?
If the speaker is not inserted into the spacers or socket firmly, the connectors will not make sufficient contact and no sound will be output.
- Is the [PROTECT] LED lit?
If the internal power amplifier section is overloaded, the amplifier will be muted to protect its circuits. The unit will automatically reset itself after a while.

Sound is distorted or noise is produced.

- Are the [LEVEL] controls of any relevant channels and/or the [MAIN LEVEL] control set too high?
- Is the [MIC/LINE] switch set to MIC?
If the input level from the source is high, setting the [MIC/LINE] switch to MIC may result in a distorted sound. Set the switch to LINE.
- Is the volume of the connected device too high?
Lower the volume of the external device.

Sound is not loud enough.

- Are the [LEVEL] controls of all relevant channels and/or the [MAIN LEVEL] control set too low?
- Is the [MIC/LINE] switch set to LINE?
Turn the [LEVEL] control to the minimum (zero). Set the switch to MIC, then slowly raise the [LEVEL] control.
- Is the volume of the connected device too low?
Raise the volume of the external device.

The high-range sounds and low-range sounds are unbalanced.

- Is the speaker properly outputting high-frequency range signals?
If not, make sure that the line array speaker is firmly inserted into the socket.

If a problem persists, please contact your Yamaha dealer.

General Specifications

■ Main specifications

System Type	Powered subwoofer with a line array speaker
Frequency Response (-10 dB)	37 Hz - 20 kHz
Coverage Angle (Horizontal × Vertical)	170° × 30°
Crossover Frequency	240 Hz
Maximum Output Level (Measured peak, IEC noise@1 m)	125 dB SPL
Power Requirements	110-120 V 60 Hz, 220-240 V 50/60 Hz
Power Consumption	25 W (idle), 91 W (1/8 power)
Dimensions (W × H × D)	System (maximum) 334 × 2,000 × 418 mm
Weight	23.0 kg (39 lbs)

■ Control panel

The number of Mixing Channels	2
Analog Inputs	Mono mic/line × 1, mono line × 1 LINK IN (MONO)
Effects	MODE (SPEECH/MUSIC/CLUB)
Outputs	LINK OUT (MONO)

■ Amplifier section

Rated Output	Dynamic	1,100 W (Subwoofer: 500 W, Line array speaker: 600 W)
---------------------	---------	---

■ Speaker section

Enclosure	Line array speaker: Enclosed Subwoofer: Bass-reflex type
Speaker Unit	Line array speaker: 1.5" (3.8 cm) Cone × 10 Subwoofer: 12" (30 cm) Cone
Dimensions (W × H × D)	Line array speaker: 67 × 582 × 86 mm Spacer (each): 67 × 555 × 86 mm Subwoofer: 334 × 550 × 418 mm
Weight	Line array speaker: 1.8 kg Spacer (each): 0.6 kg Subwoofer: 20.0 kg

■ Accessories

Included in the package	Power cord × 1, Dedicated cover × 1, Owner's Manual
Optional accessories	DL-SP1K (dedicated dolly)

Input Characteristics

Input Terminals	Connector Type		MIC/LINE SW	Input Impedance	Source Impedance	Input Level ^{*1}		
						Sensitivity ^{*2}	Nominal ^{*3}	Max. before Clipping
CH IN1	XLR Combo	XLR	MIC	3 k Ω (Balance)	150 Ω Mics/Lines	-50 dBu	-36 dBu	-10 dBu
			LINE			-24 dBu	-10 dBu	+16 dBu
		Phone	MIC	10 k Ω (Balance)	150 Ω Mics/Lines	-44 dBu	-30 dBu	-4 dBu
			LINE			-18 dBu	-4 dBu	+22 dBu
CH IN2	XLR Combo	XLR	-	10 k Ω (Balance)	150 Ω Lines	-24 dBu	-10 dBu	+16 dBu
		Phone	-	10 k Ω (Balance)	150 Ω Lines	-18 dBu	-4 dBu	+22 dBu
LINK INPUT	XLR-3-31		-	20 k Ω (Balance)	150 Ω Lines	+10 dBu	-	+24 dBu

*1. 0 dBu= 0.775 Vrms

*2. INPUT VOLUME= MAX

*3. INPUT VOLUME= Nominal (Center position)

Output Characteristics

Output Terminals	Connector Type	Output Impedance	Load Impedance	Output Level ^{*1}	
				Nominal	Max. before Clipping
LINK OUT	XLR-3-31	75 Ω	10 k Ω	+10 dBu	+24 dBu

*1. 0 dBu=0.775 Vrms

* The contents of this manual apply to the latest specifications as of the publishing date. To obtain the latest manual, access the Yamaha website then download the manual file.

Dimensions

■ Subwoofer

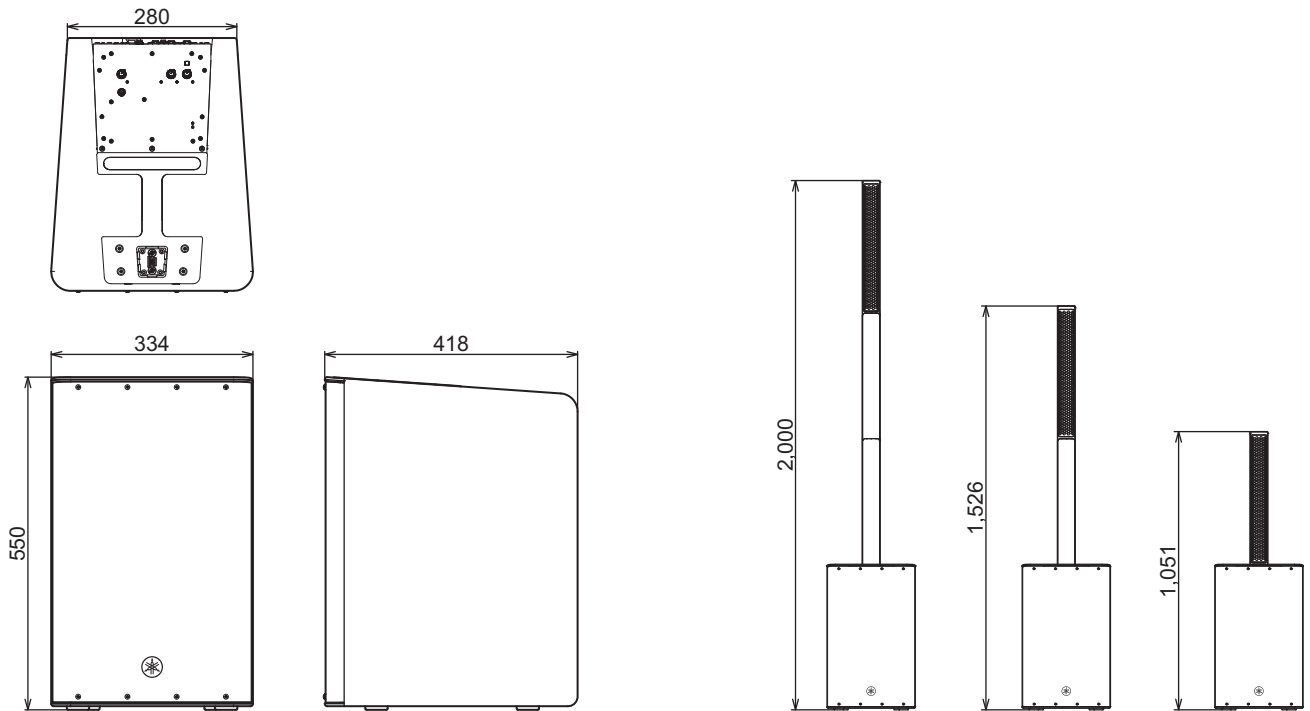

■ Line array speaker

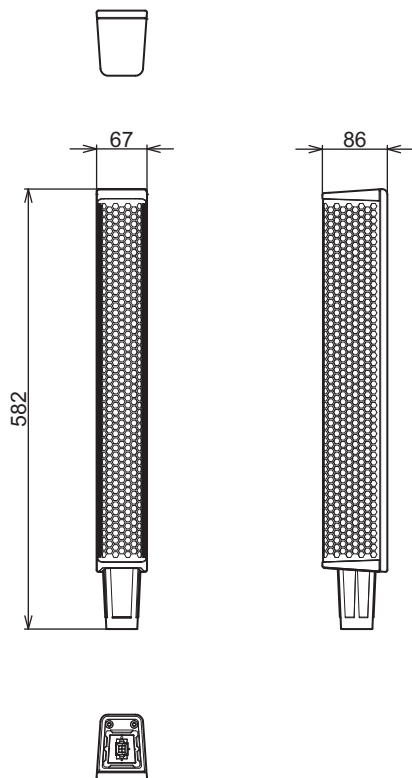

■ Spacer

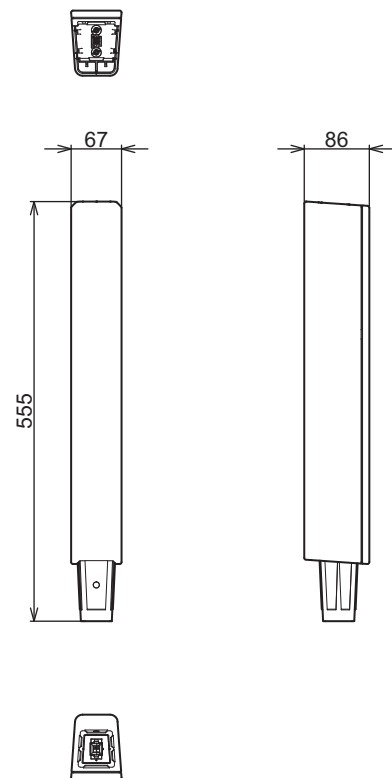

Unit: mm

Block Diagram

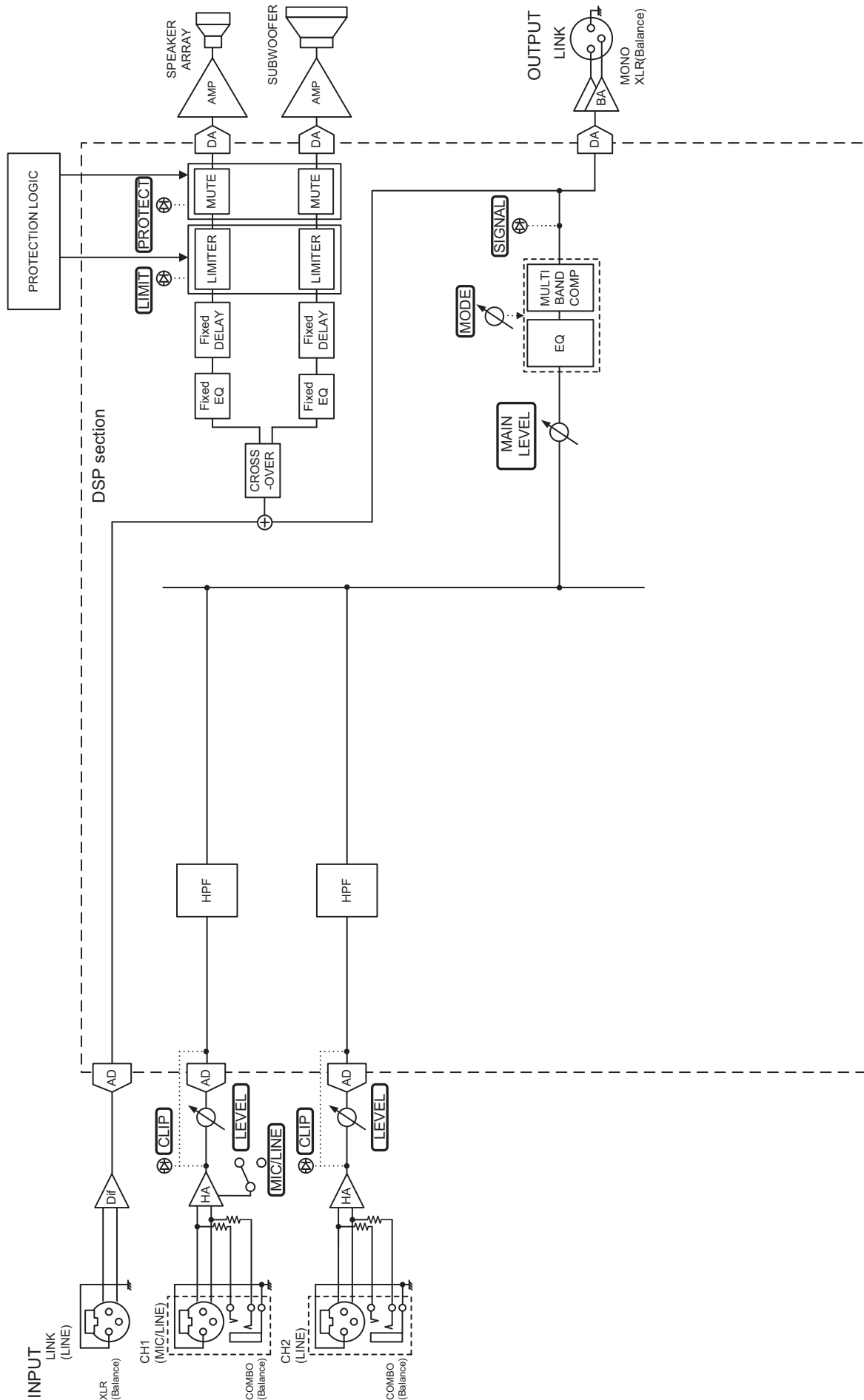

MEMO

Information for users on collection and disposal of old equipment:



This symbol on the products, packaging, and/or accompanying documents means that used electrical and electronic products should not be mixed with general household waste. For proper treatment, recovery and recycling of old products, please take them to applicable collection points, in accordance with your national legislation.

By disposing of these products correctly, you will help to save valuable resources and prevent any potential negative effects on human health and the environment which could otherwise arise from inappropriate waste handling.

For more information about collection and recycling of old products, please contact your local municipality, your waste disposal service or the point of sale where you purchased the items.

For business users in the European Union:

If you wish to discard electrical and electronic equipment, please contact your dealer or supplier for further information.

Information on Disposal in other Countries outside the European Union:

This symbol is only valid in the European Union. If you wish to discard these items, please contact your local authorities or dealer and ask for the correct method of disposal.

(58-M02 WEEE en 01)

Verbraucherinformation zur Sammlung und Entsorgung alter Elektrogeräte



Befindet sich dieses Symbol auf den Produkten, der Verpackung und/oder beiliegenden Unterlagen, so sollten benutzte elektrische Geräte nicht mit dem normalen Haushaltsabfall entsorgt werden.

In Übereinstimmung mit Ihren nationalen Bestimmungen bringen Sie alte Geräte bitte zur fachgerechten Entsorgung, Wiederaufbereitung und Wiederverwendung zu den entsprechenden Sammelstellen.

Durch die fachgerechte Entsorgung der Elektrogeräte helfen Sie, wertvolle Ressourcen zu schützen, und verhindern mögliche negative Auswirkungen auf die menschliche Gesundheit und die Umwelt, die andernfalls durch unsachgerechte Müllentsorgung auftreten könnten.

Für weitere Informationen zum Sammeln und Wiederaufbereiten alter Elektrogeräte kontaktieren Sie bitte Ihre örtliche Stadt- oder Gemeindeverwaltung, Ihren Abfallentsorgungsdienst oder die Verkaufsstelle der Artikel.

Information für geschäftliche Anwender in der Europäischen Union:

Wenn Sie Elektrogeräte ausrangieren möchten, kontaktieren Sie bitte Ihren Händler oder Zulieferer für weitere Informationen.

Entsorgungsinformation für Länder außerhalb der Europäischen Union:

Dieses Symbol gilt nur innerhalb der Europäischen Union. Wenn Sie solche Artikel ausrangieren möchten, kontaktieren Sie bitte Ihre örtlichen Behörden oder Ihren Händler und fragen Sie nach der sachgerechten Entsorgungsmethode.

(58-M02 WEEE de 01)

Informations concernant la collecte et le traitement des déchets d'équipements électriques et électroniques



Le symbole sur les produits, l'emballage et/ou les documents joints signifie que les produits électriques ou électroniques usagés ne doivent pas être mélangés avec les déchets domestiques habituels.

Pour un traitement, une récupération et un recyclage appropriés des déchets d'équipements électriques et électroniques, veuillez les déposer aux points de collecte prévus à cet effet, conformément à la réglementation nationale.

En vous débarrassant correctement des déchets d'équipements électriques et électroniques, vous contribuerez à la sauvegarde de précieuses ressources et à la prévention de potentiels effets négatifs sur la santé humaine qui pourraient advenir lors d'un traitement inapproprié des déchets.

Pour plus d'informations à propos de la collecte et du recyclage des déchets d'équipements électriques et électroniques, veuillez contacter votre municipalité, votre service de traitement des déchets ou le point de vente où vous avez acheté les produits.

Pour les professionnels dans l'Union européenne :

Si vous souhaitez vous débarrasser des déchets d'équipements électriques et électroniques, veuillez contacter votre vendeur ou fournisseur pour plus d'informations.

Informations sur la mise au rebut dans d'autres pays en dehors de l'Union européenne :

Ce symbole est seulement valable dans l'Union européenne. Si vous souhaitez vous débarrasser de déchets d'équipements électriques et électroniques, veuillez contacter les autorités locales ou votre fournisseur et demander la méthode de traitement appropriée.

(58-M02 WEEE fr 01)

Información para usuarios sobre la recogida y eliminación de los equipos antiguos



Este símbolo en los productos, embalajes y documentos anexos significa que los productos eléctricos y electrónicos no deben mezclarse con los desperdicios domésticos normales.

Para el tratamiento, recuperación y reciclaje apropiados de los productos antiguos, llévelos a puntos de reciclaje correspondientes, de acuerdo con la legislación nacional.

Al deshacerse de estos productos de forma correcta, ayudará a ahorrar recursos valiosos y a impedir los posibles efectos desfavorables en la salud humana y en el entorno que de otro modo se producirían si se trataran los desperdicios de modo inapropiado.

Para obtener más información acerca de la recogida y el reciclaje de los productos antiguos, póngase en contacto con las autoridades locales, con el servicio de eliminación de basuras o con el punto de venta donde adquirió los artículos.

Para los usuarios empresariales de la Unión Europea:

Si desea desechar equipos eléctricos y electrónicos, póngase en contacto con su vendedor o proveedor para obtener más información.

Información sobre la eliminación en otros países fuera de la Unión Europea:

Este símbolo solo es válido en la Unión Europea. Si desea desechar estos artículos, póngase en contacto con las autoridades locales o con el vendedor y pregúnteles el método correcto.

(58-M02 WEEE es 01)

Informações para os usuários relativas à coleta e à eliminação de equipamentos usados



Este símbolo, presente em produtos, embalagens e/ou incluído na documentação associada, indica que os produtos elétricos e eletrônicos usados não devem ser descartados juntamente com os resíduos domésticos em geral. O procedimento correto consiste no tratamento, na recuperação e na reciclagem de produtos usados, que devem ser levados aos pontos de coleta adequados, em conformidade com a legislação nacional em vigor.

O descarte desses produtos de forma adequada permite poupar recursos valiosos e evitar potenciais efeitos prejudiciais para a saúde pública e para o ambiente, associados ao processamento incorreto dos resíduos.

Para obter mais informações relativas à coleta e à reciclagem de produtos usados, contate as autoridades locais, o serviço de descarte de resíduos ou o ponto de venda onde foram adquiridos os itens relevantes.

Informações para usuários empresariais na União Europeia:

Para descartar equipamentos elétricos e eletrônicos, contate o seu revendedor ou fornecedor para obter informações adicionais.

Informações relativas ao descarte em países não pertencentes à União Europeia:

Este símbolo é válido exclusivamente na União Europeia. Caso pretenda descartar esses tipos de itens, contate as autoridades locais ou o seu revendedor e informe-se sobre o procedimento correto de descarte.

(58-M02 WEEE pt-BR 01)

Informazioni per gli utenti sulla raccolta e lo smaltimento di vecchia attrezzatura



Questi simboli sui prodotti, sull'imballaggio e/o sui documenti che li accompagnano, indicano che i prodotti elettrici ed elettronici non devono essere mischiati con i rifiuti generici.

Per il trattamento, il recupero e il riciclaggio appropriato di vecchi prodotti, si prega di portarli ai punti di raccolta designati, in accordo con la legislazione locale.

Smaltendo correttamente questi prodotti si potranno recuperare risorse preziose, oltre a prevenire potenziali effetti negativi sulla salute e l'ambiente che potrebbero sorgere a causa del trattamento improprio dei rifiuti.

Per ulteriori informazioni sulla raccolta e il riciclaggio di vecchi prodotti, si prega di contattare l'amministrazione comunale locale, il servizio di smaltimento dei rifiuti o il punto vendita dove sono stati acquistati gli articoli.

Per utenti imprenditori dell'Unione europea:

Se si desidera scartare attrezzatura elettrica ed elettronica, si prega di contattare il proprio rivenditore o il proprio fornitore per ulteriori informazioni.

Informazioni sullo smaltimento negli altri Paesi al di fuori dell'Unione europea:

Questi simboli sono validi solamente nell'Unione Europea; se si desidera scartare questi articoli, si prega di contattare le autorità locali o il rivenditore e richiedere informazioni sulla corretta modalità di smaltimento.

(58-M02 WEEE it 01)

Important Notice: Guarantee Information for customers in European Economic Area (EEA) and Switzerland

Important Notice: Guarantee Information for customers in EEA* and Switzerland For detailed guarantee information about this Yamaha product, and Pan-EEA* and Switzerland warranty service, please either visit the website address below (Printable file is available at our website) or contact the Yamaha representative office for your country. * EEA: European Economic Area	English
Wichtiger Hinweis: Garantie-Information für Kunden in der EWR* und der Schweiz Für nähere Garantie-Information über dieses Produkt von Yamaha, sowie über den Pan-EWR*- und Schweizer Garantieservice, besuchen Sie bitte entweder die folgend angegebene Internetadresse (eine druckfähige Version befindet sich auch auf unserer Webseite), oder wenden Sie sich an den für Ihr Land zuständigen Yamaha-Vertrieb. *EWR: Europäischer Wirtschaftsraum	Deutsch
Remarque importante: informations de garantie pour les clients de l'EEE et la Suisse Pour des informations plus détaillées sur la garantie de ce produit Yamaha et sur le service de garantie applicable dans l'ensemble de l'EEE ainsi qu'en Suisse, consultez notre site Web à l'adresse ci-dessous (le fichier imprimable est disponible sur notre site Web) ou contactez directement Yamaha dans votre pays de résidence. * EEE : Espace Economique Européen	Français
Belangrijke mededeling: Garantie-informatie voor klanten in de EER* en Zwitserland Voor gedetailleerde garantie-informatie over dit Yamaha-product en de garantieservice in heel de EER* en Zwitserland, gaat u naar de onderstaande website (u vindt een afdrukbaar bestand op onze website) of neemt u contact op met de vertegenwoordiging van Yamaha in uw land. * EER: Europese Economische Ruimte	Nederlands
Aviso importante: información sobre la garantía para los clientes del EEE* y Suiza Para una información detallada sobre este producto Yamaha y sobre el soporte de garantía en la zona EEE* y Suiza, visite la dirección web que se incluye más abajo (la versión del archivo para imprimir está disponible en nuestro sitio web) o póngase en contacto con el representante de Yamaha en su país. * EEE: Espacio Económico Europeo	Español
Avviso importante: informazioni sulla garanzia per i clienti residenti nell'EEA* e in Svizzera Per informazioni dettagliate sulla garanzia relativa a questo prodotto Yamaha e l'assistenza in garanzia nei paesi EEA* e in Svizzera, potete consultare il sito Web all'indirizzo riportato di seguito (è disponibile il file in formato stampabile) oppure contattare l'ufficio di rappresentanza locale della Yamaha. * EEA: Area Economica Europea	Italiano
Aviso importante: informações sobre as garantias para clientes da AEE* e da Suíça Para obter uma informação pormenorizada sobre este produto da Yamaha e sobre o serviço de garantia na AEE* e na Suíça, visite o site a seguir (o arquivo para impressão está disponível no nosso site) ou entre em contato com o escritório de representação da Yamaha no seu país. * AEE: Área Económica Européia	Português
Σημαντική σημείωση: Πληροφορίες εγγύησης για τους πελάτες στον ΕΟΧ* και Ελβετία Για λεπτομερείς πληροφορίες εγγύησης σχετικά με το παρόν προϊόν της Yamaha και την κάλυψη εγγύησης σε όλες τις χώρες του ΕΟΧ και την Ελβετία, επισκεφτείτε την παρακάτω ιστοσελίδα (Εκτυπώσιμη μορφή είναι διαθέσιμη στην ιστοσελίδα μας) ή απευθυνθείτε στην αντιπροσωπεία της Yamaha στη χώρα σας. * ΕΟΧ: Ευρωπαϊκός Οικονομικός Χώρος	Ελληνικά
Viktigt: Garantiinformation för kunder i EES-området* och Schweiz För detaljerad information om denna Yamahaprodukt samt garantiservice i hela EES-området* och Schweiz kan du antingen besöka nedanstående webbadress (en utskriftsvänlig fil finns på webbplatsen) eller kontakta Yamahas officiella representant i ditt land. * EES: Europeiska Ekonomiska Samarbetsområdet	Svenska
Viktig merknad: Garantiinformasjon for kunder i EØS* og Sveits Detaljert garantiinformasjon om dette Yamaha-produktet og garantiservice for hele EØS-området* og Sveits kan fås enten ved å besøke nettstedene nedenfor (utskriftsversjon finnes på våre nettsider) eller kontakte kontaktpunktet Yamaha-kontoret i landet der du bor. *EØS: Det europeiske økonomiske samarbeidsområdet	Norsk
Vigtig oplysning: Garantioplysninger til kunder i EØ* og Schweiz De kan finde detaljerede garantioplysninger om dette Yamaha-produkt og den fælles garantiserviceordning for EØ* (og Schweiz) ved at besøge det websted, der er angivet nedenfor (der findes en fil, som kan udskrives, på vores websted), eller ved at kontakte Yamahas nationale repræsentationskontor i det land, hvor De bor. * EØ: Det Europæiske Økonomiske Område	Dansk
Tärkeä ilmoitus: Takuutiedot Euroopan talousalueen (ETA)* ja Sveitsin asiakkaille Tämän Yamaha-tuotteen sekä ETA-alueen ja Sveitsin takuuta koskevat yksityiskohtaiset tiedot saatte alla olevasta nettiosoitteesta. (Tulostettava tiedosto saatavissa sivustollamme.) Voit myös ottaa yhteyttä paikalliseen Yamaha-edustajaan. *ETA: Euroopan talousalue	Suomi
Ważne: Warunki gwarancyjne obowiązujące w EOG* i Szwajcarii Aby dowiedzieć się więcej na temat warunków gwarancyjnych tego produktu firmy Yamaha i serwisu gwarancyjnego w całym EOG* i Szwajcarii, należy odwiedzić wskazaną poniżej stronę internetową (Plik gotowy do wydruku znajduje się na naszej stronie internetowej) lub skontaktować się z przedstawicielstwem firmy Yamaha w swoim kraju. * EOG — Europejski Obszar Gospodarczy	Polski
Důležité oznámení: Záruční informace pro zákazníky v EHS* a ve Švýcarsku Podrobné záruční informace o tomto produktu Yamaha a záručním servisu v celém EHS* a ve Švýcarsku naleznete na níže uvedené webové adrese (soubor k tisku je dostupný na našich webových stránkách) nebo se můžete obrátit na zastoupení firmy Yamaha ve své zemi. * EHS: Evropský hospodářský prostor	Česky
Fontos figyelemztetés: Garancia-információk az EGT* területén és Svájcban élő vásárlók számára A jelen Yamaha termékre vonatkozó részletes garancia-információk, valamint az EGT*-re és Svájcra kiterjedő garanciális szolgáltatás tekintetében keresse fel webhelyünket az alábbi címen (a webhelyen nyomtatható fájl is található), vagy pedig lépjen kapcsolatba az országában működő Yamaha képviselői irodával. * EGT: Európai Gazdasági Térség	Magyar
Oluline märkus: Garantiiteave Euroopa Majanduspiirkonna (EMP)* ja Šveitsi klientidele Täpsema teabe saamiseks selle Yamaha toote garantii ning kogu Euroopa Majanduspiirkonna ja Šveitsi garantiiteeninduse kohta, külastage palun veebisaiti alljärgneval aadressil (meie saidil on saadaval printitav fail) või pöörduge Teie regiooni Yamaha esinduse poole. * EMP: Euroopa Majanduspiirkond	Eesti keel
Svarīgs paziņojums: garantijas informācija klientiem EEZ* un Šveicē Lai saņemtu detalizētu garantijas informāciju par šo Yamaha produktu, kā arī garantijas apkalpošanu EEZ* un Šveicē, lūdzu, apmeklējiet zemāk norādīto tīmekļa vietnes adresi (tīmekļa vietnē ir pieejams drukājams fails) vai sazinieties ar jūsu valsti apkalpojošo Yamaha pārstāvniecību. * EEZ: Eiropas Ekonomikas zona	Latviešu
Dėmesio: informacija dėl garantijos pirkėjams EEE* ir Šveicarijoje Jei reikia išsamios informacijos apie šį „Yamaha“ produktą ir jo techninę priežiūrą visoje EEE* ir Šveicarijoje, apsilankykite mūsų svetainėje toliau nurodytu adresu (svetainėje yra spausdintinas failas) arba kreipkitės į „Yamaha“ atstovybę savo šaliai. *EEE – Europos ekonominė erdvė	Lietuvių kalba
Dôležité upozornenie: Informácie o záruke pre zákazníkov v EHP* a Švajčiarsku Podrobné informácie o záruke týkajúce sa tohto produktu od spoločnosti Yamaha a garančnom servise v EHP* a Švajčiarsku nájdete na webovej stránke uvedenej nižšie (na našej webovej stránke je k dispozícii súbor na tlač) alebo sa obráťte na zástupcu spoločnosti Yamaha vo svojej krajine. * EHP: Európsky hospodársky priestor	Slovenčina
Pomembno obvestilo: Informacije o garanciji za kupce v EGP* in Švici Za podrobnejše informacije o tem Yamahinem izdelku ter garancijskem servisu v celotnem EGP in Švici, obiščite spletno mesto, ki je navedeno spodaj (natisljiva datoteka je na voljo na našem spletnem mestu), ali se obrnite na Yamahinega predstavnika v svoji državi. * EGP: Evropski gospodarski prostor	Slovenščina
Важно съобщение: Информация за гаранцията за клиенти в ЕИП* и Швейцария За подробна информация за гаранцията за този продукт на Yamaha и гаранционното обслужване в паневропейската зона на ЕИП* и Швейцария или посетете посочения по-долу уеб сайт (на нашия уеб сайт има файл за печат), или се свържете с представителния офис на Yamaha във вашата страна. * ЕИП: Европейско икономическо пространство	Български език
Notificare importantă: Informații despre garanție pentru clienții din SEE* și Elveția Pentru informații detaliate privind acest produs Yamaha și serviciul de garanție Pan-SEE* și Elveția, vizitați site-ul la adresa de mai jos (fișierul imprimabil este disponibil pe site-ul nostru) sau contactați biroul reprezentanței Yamaha din țara dumneavoastră. * SEE: Spațiul Economic European	Limba română
Važna obavijest: Informacije o jamstvu za države EGP-a i Švicarske Za detaljne informacije o jamstvu za ovaj Yamahin proizvod te jamstvenom servisu za cijeli EGP i Švicarsku, molimo Vas da posjetite web-stranicu navedenu u nastavku ili kontaktirate ovlaštenog Yamahinog dobavljača u svojoj zemlji. * EGP: Evropski gospodarski prostor	Hrvatski

<https://europe.yamaha.com/warranty/>

URL_5

188 DXL1K Owner's Manual

MEMO

MEMO

ADDRESS LIST

NORTH AMERICA

CANADA

Yamaha Canada Music Ltd.
135 Milner Avenue, Toronto, Ontario,
M1S 3R1, Canada
Tel: +1-416-298-1311

U.S.A.

Yamaha Corporation of America
6600 Orangethorpe Avenue, Buena Park, CA 90620,
U.S.A.
Tel: +1-714-522-9011

CENTRAL & SOUTH AMERICA

MEXICO

Yamaha de México, S.A. de C.V.
Av. Insurgentes Sur 1647 Piso 9, Col. San José
Insurgentes, Delegación Benito Juárez, CDMX,
C.P. 03900, México
Tel: +52-55-5804-0600

BRAZIL

Yamaha Musical do Brasil Ltda.
Praça Professor José Lannes, 40, Cjs 21 e 22, Brooklin
Paulista Novo CEP 04571-100 – São Paulo – SP,
Brazil
Tel: +55-11-3704-1377

ARGENTINA

**Yamaha Music Latin America, S.A.,
Sucursal Argentina**
Olga Cossetini 1553, Piso 4 Norte,
Madero Este-C1107CEK,
Buenos Aires, Argentina
Tel: +54-11-4119-7000

PANAMA AND OTHER LATIN

AMERICAN/CARIBBEAN REGIONS

Yamaha Music Latin America, S.A.
Edif. Torre Banco General, Piso 7, Urbanización
Marbella, Calle 47 y Aquilino de la Guardia,
Ciudad de Panamá, República de Panamá
Tel: +507-269-5311

EUROPE

THE UNITED KINGDOM/IRELAND

Yamaha Music Europe GmbH (UK)
Sherbourne Drive, Tilbrook, Milton Keynes,
MK7 8BL, U.K.
Tel: +44-1908-366700

GERMANY

Yamaha Music Europe GmbH
Siemensstrasse 22-34, 25462 Rellingen, Germany
Tel: +49-4101-303-0

SWITZERLAND/LIECHTENSTEIN

**Yamaha Music Europe GmbH, Branch
Switzerland in Thalwil**
Seestrasse 18a, 8800 Thalwil, Switzerland
Tel: +41-44-3878080

AUSTRIA/BULGARIA/ CZECH REPUBLIC/HUNGARY/ ROMANIA/SLOVAKIA/SLOVENIA

**Yamaha Music Europe GmbH
Branch Austria**
Schleiergasse 20, 1100 Wien, Austria
Tel: +43-1-60203900

POLAND

Yamaha Music Europe GmbH
Sp.z o.o. Oddział w Polsce
ul. Wielicka 52, 02-657 Warszawa, Poland
Tel: +48-22-880-08-88

MALTA

Olimpus Music Ltd.
Valletta Road, Mosta MST9010, Malta
Tel: +356-2133-2093

NETHERLANDS/BELGIUM/ LUXEMBOURG

Yamaha Music Europe Branch Benelux
Clarissenhof 5b, 4133 AB Vianen, The Netherlands
Tel: +31-347-358040

FRANCE

Yamaha Music Europe
7 rue Ambroise Croizat, Zone d'activités de Pariest,
77183 Croissy-Beaubourg, France
Tel: +33-1-6461-4000

ITALY

Yamaha Music Europe GmbH, Branch Italy
Via Tinelli N.67/69 20855 Gerno di Lesmo (MB),
Italy
Tel: +39-039-9065-1

SPAIN/PORTUGAL

**Yamaha Music Europe GmbH Ibérica, Sucursal
en España**
Ctra. de la Coruña km. 17,200, 28231
Las Rozas de Madrid, Spain
Tel: +34-91-639-88-88

GREECE

Philippos Nakas S.A. The Music House
19th klm. Leof. Lavriou 190 02 Peania – Attiki,
Greece
Tel: +30-210-6686168

SWEDEN/FINLAND/ICELAND

**Yamaha Music Europe GmbH Germany filial
Scandinavia**
JA Wettergrensgata 1, 400 43 Göteborg, Sweden
Tel: +46-31-89-34-00

DENMARK

**Yamaha Music Denmark,
Fillial of Yamaha Music Europe GmbH, Tyskland**
Generatorvej 8C, ST. TH. , 2860 Søborg, Denmark
Tel: +45-44-92-49-00

NORWAY

**Yamaha Music Europe GmbH Germany -
Norwegian Branch**
Grini Næringspark 1, 1332 Østerås, Norway
Tel: +47-6716-7800

CYPRUS

Yamaha Music Europe GmbH
Siemensstrasse 22-34, 25462 Rellingen, Germany
Tel: +49-4101-303-0

RUSSIA

Yamaha Music (Russia) LLC.
Room 37, entrance 7, bld. 7, Kievskaya street,
Moscow, 121059, Russia
Tel: +7-495-626-5005

OTHER EUROPEAN REGIONS

Yamaha Music Europe GmbH
Siemensstrasse 22-34, 25462 Rellingen, Germany
Tel: +49-4101-3030

AFRICA

Yamaha Music Gulf FZE
JAFZA-16, Office 512, P.O.Box 17328,
Jebel Ali FZE, Dubai, UAE
Tel: +971-4-801-1500

MIDDLE EAST

TURKEY

Yamaha Music Europe GmbH
Merkezi Almanya Türkiye İstanbul Şubesi
Mor Sumbul Sokak Varyap Meridian Business
1.Blok No:1 113-114-115
Bati Atasehir Istanbul, Turkey
Tel: +90-216-275-7960

OTHER REGIONS

Yamaha Music Gulf FZE
JAFZA-16, Office 512, P.O.Box 17328,
Jebel Ali FZE, Dubai, UAE
Tel: +971-4-801-1500

ASIA

THE PEOPLE'S REPUBLIC OF CHINA

Yamaha Music & Electronics (China) Co.,Ltd.
2F, Yunhedasha, 1818 Xinzha-lu, Jingan-qu,
Shanghai, China
Tel: +86-400-051-7700

INDIA

Yamaha Music India Private Limited
P-401, JMD Megapolis, Sector-48, Sohna Road,
Gurugram-122018, Haryana, India
Tel: +91-124-485-3300

INDONESIA

PT Yamaha Musik Indonesia Distributor
Yamaha Music Center Bldg. Jalan Jend. Gatot
Subroto Kav. 4, Jakarta 12930, Indonesia
Tel: +62-21-520-2577

KOREA

Yamaha Music Korea Ltd.
11F, Prudential Tower, 298, Gangnam-daero,
Gangnam-gu, Seoul, 06253, Korea
Tel: +82-2-3467-3300

MALAYSIA

Yamaha Music (Malaysia) Sdn. Bhd.
No.8, Jalan Perbandaran, Kelana Jaya, 47301
Petaling Jaya, Selangor, Malaysia
Tel: +60-3-78030900

SINGAPORE

Yamaha Music (Asia) Private Limited
Block 202 Hougang Street 21, #02-00,
Singapore 530202, Singapore
Tel: +65-6740-9200

TAIWAN

Yamaha Music & Electronics Taiwan Co.,Ltd.
2F., No.1, Yuandong Rd., Banqiao Dist.,
New Taipei City 22063, Taiwan (R.O.C.)
Tel: +886-2-7741-8888

THAILAND

Siam Music Yamaha Co., Ltd.
3, 4, 15, 16th Fl., Siam Motors Building,
891/1 Rama 1 Road, Wangmai,
Pathumwan, Bangkok 10330, Thailand
Tel: +66-2215-2622

VIETNAM

Yamaha Music Vietnam Company Limited
15th Floor, Nam A Bank Tower, 201-203 Cach
Mang Thang Tam St., Ward 4, Dist.3,
Ho Chi Minh City, Vietnam
Tel: +84-8-3818-1122

OTHER ASIAN REGIONS

<http://asia.yamaha.com/>

OCEANIA

AUSTRALIA

Yamaha Music Australia Pty. Ltd.
Level 1, 80 Market Street, South Melbourne,
VIC 3205, Australia
Tel: +61-3-9693-5111

REGIONS AND TRUST TERRITORIES IN PACIFIC OCEAN

<http://asia.yamaha.com/>

雅马哈乐器音响（中国）投资有限公司

上海市静安区新闻路 1818 号云和大厦 2 楼

客户服务热线：4000517700

公司网址：<https://www.yamaha.com.cn>

制造商：雅马哈株式会社

制造商地址：日本静冈县滨松市中区中泽町 10-1

进口商：雅马哈乐器音响（中国）投资有限公司

进口商地址：上海市静安区新闻路 1818 号云和大厦 2 楼

原产地：印度尼西亚

台灣山葉音樂股份有限公司

YAMAHA MUSIC & ELECTRONICS TAIWAN CO.,LTD.

<https://tw.yamaha.com>

總公司：(02) 7741-8888 新北市板橋區遠東路 1 號 2 樓

客服專線：0809-091388

ヤマハ株式会社

〒430-8650 静岡県浜松市中区中沢町10-1

Yamaha Pro Audio global website
<https://www.yamahaproaudio.com/>
Yamaha Downloads
<https://download.yamaha.com/>

Manual Development Group
© 2022 Yamaha Corporation
Published 05/2022
2022年5月 发行
IPEI-A0

VFA9430