

## HX-5W-WP

### SPEAKER SYSTEM



The HX-5W-WP is a 2-way compact speaker system that permits both constant directivity control over a wide frequency range and changes in directivity. It is ideal for reproducing clear sound in spaces with long reverberation times or high background noises. In locations where the speaker is directly exposed to rain, periodical check is required as the deterioration of speaker may progress depending on the installation environments.

### Key features

- Power handling: 600W Continuous Program@8 ohms
- One module is composed of 1 x 4.72" cone-type LF driver and 3 x 1" balanced dome tweeters
- Adjustable dispersion angle 15°, 30°, 45° and 60°
- Maximum four speaker units can be stacked
- Splash-proof (IPX4 rated)

## Specifications

Enclosure	Sealed type
Power Consumption	Continuous pink noise: 200 W, Continuous program: 600 W
Impedance	8 $\Omega$
Sensitivity	96 dB (60° mode), 97 dB (45° mode), 98 dB (30° mode), 99 dB (15° mode)
Frequency Response	95 Hz - 20 kHz (-10 dB) (60° mode), 100 Hz- 20 kHz (-10 dB) (45° mode), 105 Hz - 20 kHz (-10 dB) (30° mode), 110 Hz - 20 kHz (-10 dB) (15° mode)
Crossover Frequency	4 kHz
Directivity Angle	Horizontal: 100° (over 2,000 Hz) Vertical: 60° (over 800 Hz), 45° (over 1.2 kHz), 30° (over 1.6 kHz), 15° (over 3.2 kHz) variable
Speaker Component	Low frequency: 12 cm cone-type x 4, High frequency: Balanced dome-type x 12
Speaker Cable	2-core cable cord with diameter of 6 mm
Dust/Water Protection	IPX4 (Install with the every speaker module downward.)
Installation Environment	Indoor installation, under-eave installation(*1)
Operating Temperature	-15 °C to +50 °C
Finish	Enclosure: Polypropylene, white Punched net: Surface-treated steel plate, white, rust proof coating
Dimensions	408 (W) x 546 (H) x 342 (D) mm
Weight	16 kg
Included Accessories	Hanging bracket x 2, Hex. wrench x 1
Optional Accessories	Matching transformer : MT-200 Speaker mounting bracket: HY-PF1WP, HY-CW1WP, HY-WM1WP, HY-WM2WP, HY-CN1B-WP

(\*1) Avoid installing the speaker in locations close to the seashore or in indoor swimming facilities that are not well ventilated. In such locations, the bracket may be vulnerable to corrosion, eventually allowing the speaker to fall resulting in personal injury.

# Dimensions

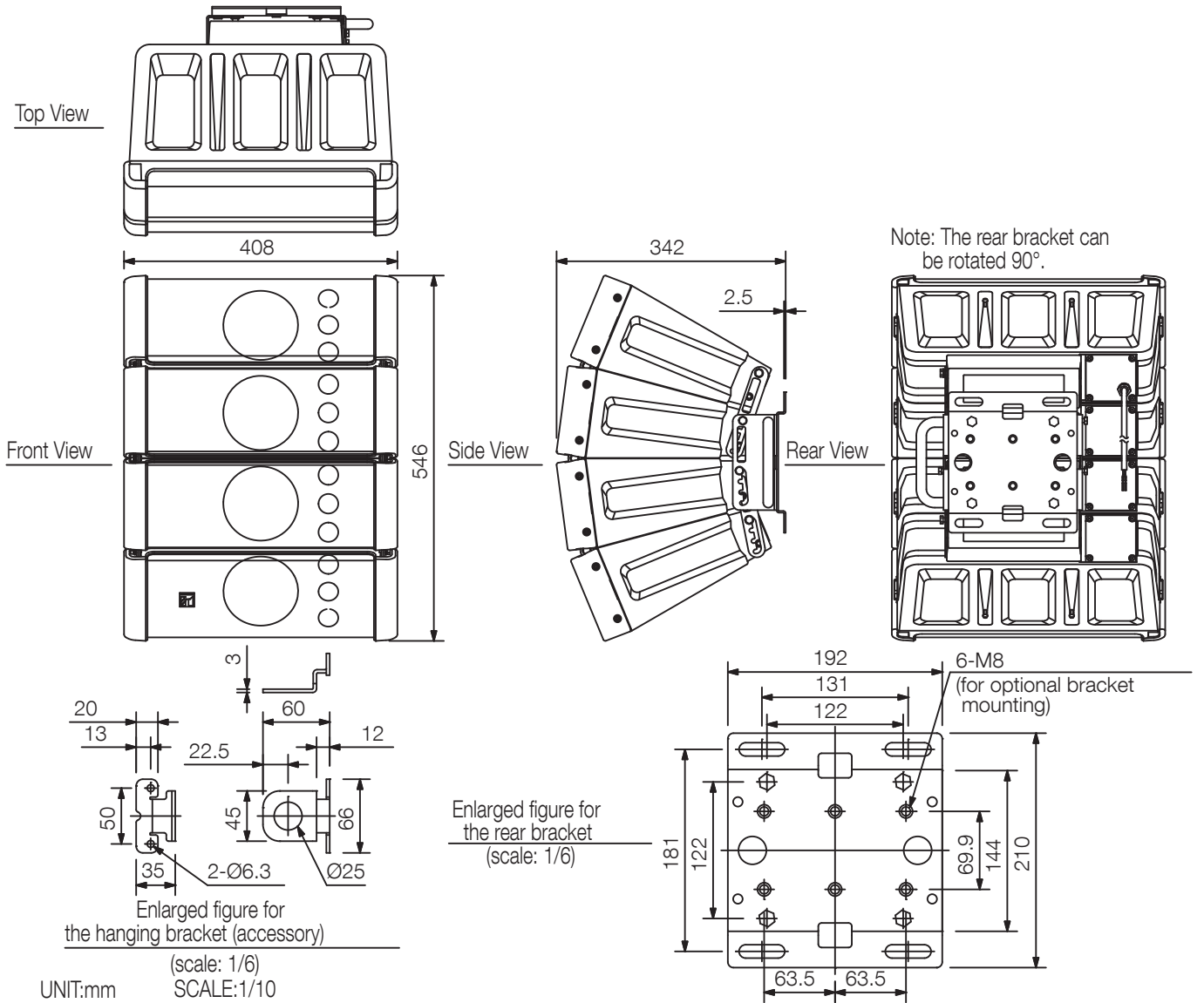

## Dimensions

Example for adjustment of the directivity angle

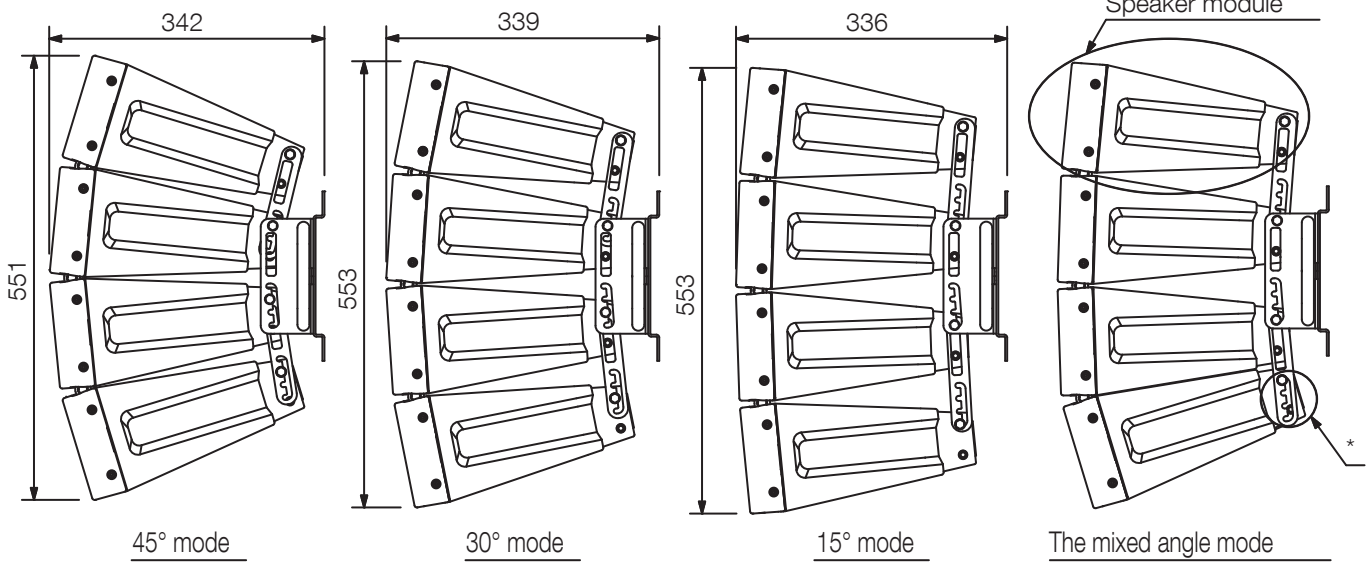

\* The angle between the successive speaker modules can be changed by four steps individually.

## Dimensions

Example for hanging bracket mounting

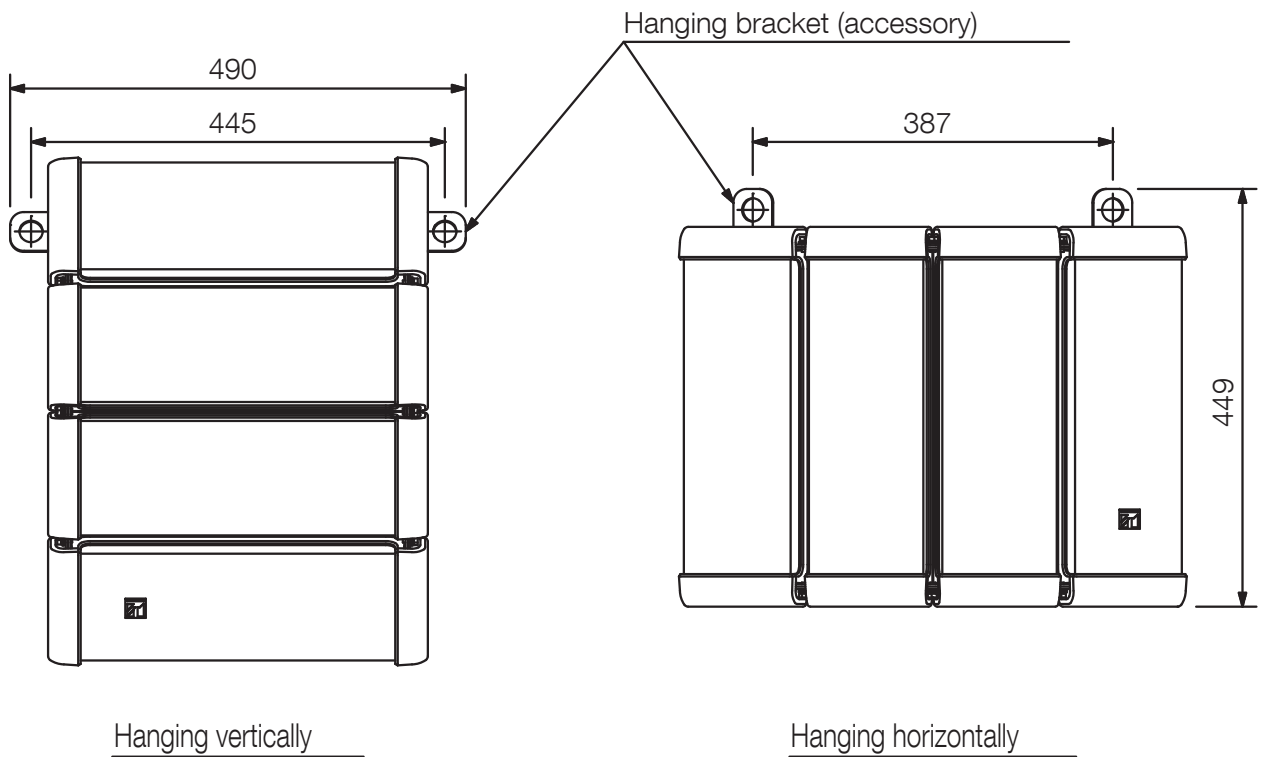

Note: Every speaker module must be aimed horizontally or down to keep the weather resistant capability.

UNIT:mm

SCALE:1/10

## A&E specifications

The speaker shall be an indoor/outdoor splash-proof, modular, direct-radiating two-way design with integral mounting bracket.

The low-frequency section shall consist of four direct-radiating 4.72" (12 cm) cone-type drivers arranged in a vertical line, with each driver housed in a separate sealed enclosure module. The high frequency section shall consist of twelve direct-radiating 1" (25 mm) balanced-dome tweeters arranged in a vertical line, mounted adjacent to the low frequency drivers, with 3 tweeters per enclosure module. The speaker shall incorporate line array design elements to achieve highly controlled directivity in the vertical plane, and a contoured waveguide-baffle design for controlled directivity in the horizontal plane. Speaker construction shall be modular and shall allow on-site adjustment of directivity in the vertical plane over a range from 15 degrees to 60 degrees nominal coverage angle, in 15 degree increments. Horizontal coverage shall be 100 degrees nominal, irrespective of the adjustment of the vertical angle. The integral mounting bracket shall be made of 12 gauge steel and shall allow for a 90 degree rotation of the speaker orientation. The integral frequency dividing network shall include both low pass and high pass filter sections and shall be optimized for smooth on-and off-axis frequency response in all directional configurations. The crossover frequency shall be 4 kHz. The speaker input connectors shall include one screw terminal connection and two Neutrik NL4 type sockets, wired in parallel for pass-through to additional speakers.

The speaker shall meet the following performance criteria. Power handling: 200 watts continuous pink noise, 600 watts continuous program. Frequency response (10 dB below rated pressure sensitivity, without external equalization): 70 Hz to 20 kHz in 60 degree mode, 75 Hz to 20 kHz in 45 degree mode, 80 Hz to 20 kHz in 30 degree mode, 85 Hz to 20 kHz in 15 degree mode. Pressure sensitivity (1 watt at 1 m): 96 dB in 60 degree mode, 97 dB in 45 degree mode, 98 dB in 30 degree mode, 99 dB in 15 degree mode. Impedance: 8 ohms nominal. When the optional line matching transformer model MT-200 is installed, the available power taps for 70.7 volt line applications shall be 30, 60, 100 and 200 watts (167, 83, 50, and 25 ohms respectively).

The speaker's design approach shall be such that two or more may be combined in a linear array to increase output and/or coverage with no degradation of the consistency of the coverage pattern. When two are combined, the available vertical coverage angles (-6 dB cutoff) shall be 30 degrees (+ 12/- 5 degrees from 500 Hz to 16 kHz), 60 degrees (+/- 15 degrees from 400 to 12.5 kHz), 90 degrees (+10/-20 degrees from 250 Hz to 20 kHz), and 110 degrees (+/- 20 degrees from 200 Hz to 20 kHz). Horizontal coverage shall remain 100 degrees nominal. Horizontal coverage shall remain 100 degrees nominal. Available accessory brackets shall allow for both the co-joining of multiple units in a linear array and the suspension of the array in vertical or horizontal orientation.

The speaker shall have an IEC 529 splash-proof rating of IP-X4. The modular enclosure shall be made of polypropylene, with stainless steel brackets and hardware. The dimensions (W x H x D) shall be 16.1" x 21.5" x 13.5" (408 mm x 546 mm x 342 mm) and weight shall be 35.3 lbs. (16 kg). Suspension brackets shall be supplied with the speaker to allow suspension in either vertical or horizontal orientation. Available accessory brackets for wall, ceiling and stand mounting shall be made of stainless steel.

The loudspeaker shall be TOA model HX-5B-WP / HX-5W-WP

The outdoor connection bracket shall be TOA model HY-CN1B-WP / HY-CN1W-WP.

The outdoor ceiling mount bracket shall be TOA model HY-CW1WP.

The outdoor pre-install rigging frame shall be TOA model HY-PF1WP.

The outdoor wall/ceiling mounting bracket shall be TOA model HY-WM1WP.

The outdoor wall/ceiling direct mounting bracket shall be TOA model TOA model HY-WM2WP.