

## ER-1206

### 6W SPLASH PROOF MEGAPHONE



The ER-1206 is a compact splash-proof megaphone rated at 6 W output and features IPX5 water-jet-resistant designs. It operates with 6 R6P batteries, or 4 R6P batteries when the battery spacer (accessory) is used.

### Key features

- Compact & lightweight
- Good sound quality due to wide frequency response
- Directional microphone with press-to-talk switch
- Neodymium magnet for high performance
- Battery saving operation
- Rugged enclosure

## Specifications

Power Source	R6P (AA) x 6 (9 V DC) or R6P (AA) x 4 (6 V DC)
Rated Output	6 W (when using six R6P batteries)
Maximum Output	10 W (when using six R6P batteries)
Battery Life	When using six R6P batteries: Approx. 8 hours (JEITA)(*1) When using four R6P batteries(*2): Approx. 5 hours (JEITA)(*1)
Audible Range	Approx. 250 m (JEITA)(*1)
Frequency Response	450 Hz - 6 kHz (SPL -20 dB)
Magnetic Circuit	Neodymium magnet, inner magnet type
Diaphragm	Polyimide film (voice coil, bobbin)
Water Protection	IPX5
Operating Temperature	-10 °C to +40 °C
Finish	Horn: ASA resin, clear dark gray Other: ASA resin, dark gray Strap: Nylon, black
Dimensions	154 (W) x 266 (H) x 250 (D) mm
Weight	660 g (without batteries)
Included Accessories	Battery spacer ...1
Optional Accessories	Wall mounting bracket for megaphone: SP-1100

(\*1) JEITA: Japan electronics and information technology industries association.

(\*2) With the additional use of the supplied battery spacer.

## Dimensions

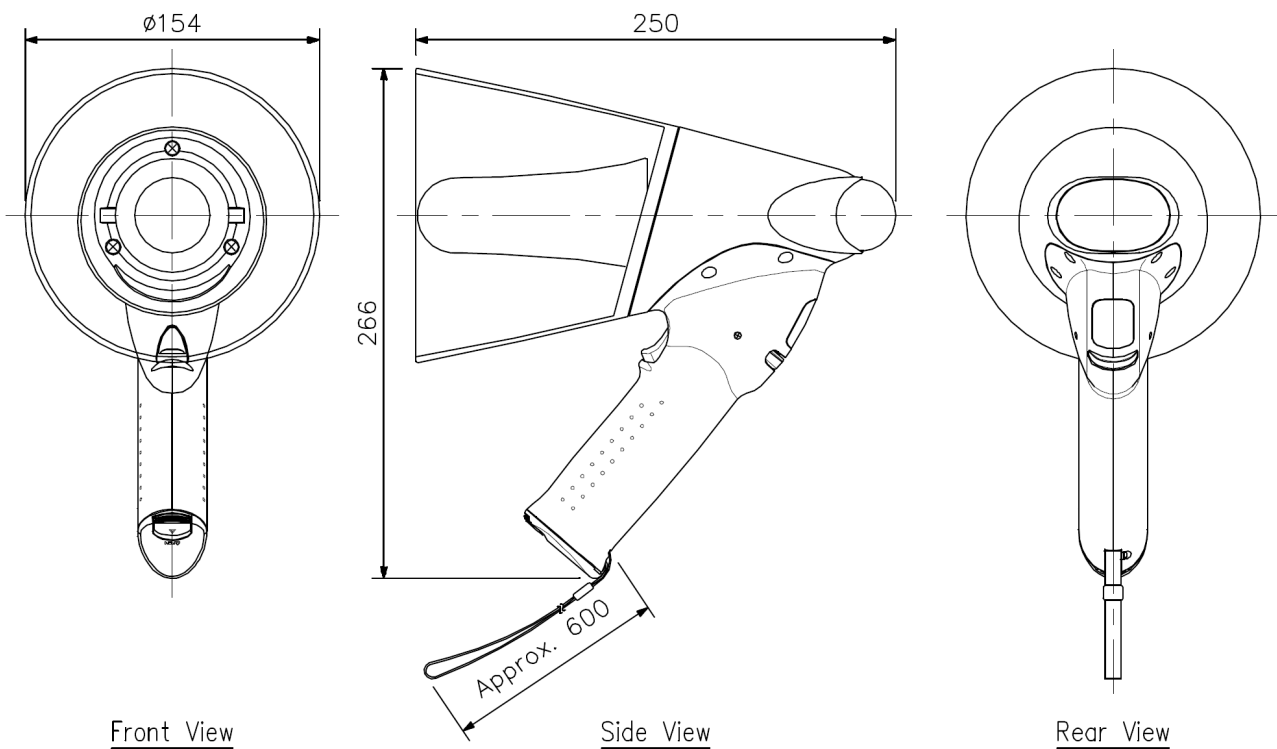

Front View

Side View

Rear View

<Note on the audible range and battery life>

1. The indications of the audible range and battery life are based on the JEITA Standard(\*1).
2. Audible Range presumes that the megaphone employs new batteries and is used on a quiet street.  
It varies depending on such conditions as battery consumption, ambient noise, wind direction and obstacles.
3. Battery Life assumes that megaphone is used for 30 minutes a day.

UNIT:mm