

# R-07

High Resolution Audio Recorder

[Reference Guide](#)

# Contents

<b>Panel Descriptions</b> .....	<b>3</b>	<b>Controlling the R-07 from a Mobile Device</b> .....	<b>26</b>
Main Screen.....	5	Installing the App “R-07 Remote” .....	26
<b>Getting Ready</b> .....	<b>6</b>	Making Settings on the R-07 .....	26
Installing the Batteries .....	6	Making Settings on the Mobile Device .....	26
Supplying Power from the USB Port.....	6	Starting the R-07 Remote .....	26
Turning the Power On/Off.....	6	<b>Using the Metronome</b> .....	<b>28</b>
Specifying the Battery Type .....	7	Using the Metronome by Itself .....	28
Setting the Date and Time .....	7	Sounding the Metronome During Recording .....	28
Preparing a microSD Card .....	8	<b>Using the Tuner</b> .....	<b>29</b>
Inserting a microSD Card .....	8	Basic Operation for the Tuner or Graphic Tuner .....	29
Formatting a microSD Card .....	9	Tuner.....	29
Using Headphones or Speakers.....	10	Graphic Tuner .....	30
Connecting External Speakers .....	10	<b>Connecting to Your Computer</b> .....	<b>31</b>
Connecting Bluetooth® Speakers or Headphones... ..	10	Transferring Files with a Computer (Mass Storage) .....	31
<b>Recording</b> .....	<b>12</b>	Connecting the R-07 to Your Computer .....	31
Basic Recording Operation .....	12	Disconnecting from Your Computer .....	31
Recalling Settings for Specific Purposes .....	13	<b>Handling Files and Folders</b> .....	<b>32</b>
Saving an Edited Scene .....	13	Basic Operation .....	32
Initializing an Edited Scene.....	13	Opening a File or Folder.....	33
Specifying the Recording Quality .....	14	Viewing Information.....	33
Sample Rate .....	14	Deleting a File or Folder.....	34
Rec Mode.....	14	Renaming a File or Folder .....	34
Setting the Sample Rate and Rec Mode.....	14	Moving a File.....	34
Approximate Recording Times .....	15	Copying a File .....	34
Using Limiter or AGC.....	16	Dividing a File .....	35
Cutting the Low-Frequency Range.....	16	Combining Files .....	35
Adjusting the Input Level .....	17	Deleting Unwanted Portions of a File (Trim) .....	36
Manually Adjusting the Input Level.....	17	Creating an MP3 File.....	36
Using the Rehearsal Function .....	18	Repairing a File.....	37
Using the Pre-Rec Function.....	18	Creating a Folder .....	37
Using the Auto Rec Start Function .....	18	<b>Settings for the R-07</b> .....	<b>38</b>
Recording Instruments or Vocals.....	19	Basic Procedure .....	38
Using the Built-in Mics.....	19	<b>Error Messages</b> .....	<b>41</b>
Using an External Mic .....	19	<b>Troubleshooting</b> .....	<b>42</b>
Recording from a Cassette or CD.....	20	Problems with Recording .....	42
Assigning a Marker During Recording.....	21	Problems with Playback.....	42
Manual Marking .....	21	Problems with Bluetooth Functionality.....	43
Splitting the File During Recording .....	21	Other Problems .....	43
Splitting Manually.....	21	<b>Main Specifications</b> .....	<b>45</b>
Splitting Automatically .....	21		
<b>Playback</b> .....	<b>22</b>		
Basic Playback Operation .....	22		
Play Mode and Repeat Settings.....	22		
Assigning Markers in a File .....	23		
Repeatedly Playing a Portion of a File .....	23		
Changing the Playback Speed.....	24		
Using the INPUT [+] [-] Buttons to Change the			
Playback Speed .....	24		
Applying Reverb to the Playback .....	24		
Applying Reverb .....	24		
Changing the Reverb Depth .....	25		
Types of Files that Can be Played .....	25		

Copyright © 2018 ROLAND CORPORATION

\* This document explains the specifications of the product at the time that the document was issued. For the latest information, refer to the Roland website.

# Panel Descriptions

**Built-in mics**  
This is a stereo mic built into the unit.

**Display**  
This shows various types of information for the R-07.

**PEAK indicator**  
This will light when the input volume is excessive.

**Bluetooth indicator**  
This blinks when pairing with a Bluetooth speaker or headphones (p. 10). It is lit if the R-07 is connected to a Bluetooth speaker or headphones, or when the remote control is on (p. 26).

**[SCENE] button**  
This button lets you switch scenes (p. 13) that recall settings suitable for a specific recording situation.  
Long-press this button to flip the display vertically.

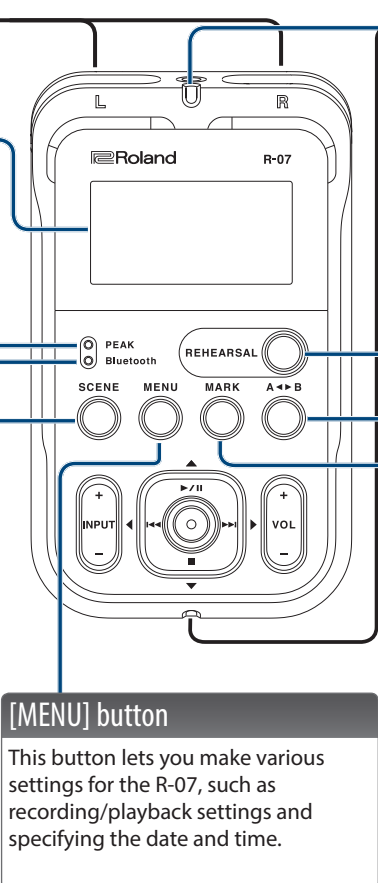

**Remote indicator**

Operation	Status
Lit	Recording
Blinking (slow)	Record-standby
Blinking (fast)	Input overload

**[REHEARSAL] button**  
This button automatically sets the appropriate recording level (p. 18).

**[A ↔ B] button**  
This button lets you repeatedly play between two points (the A–B region) of a file (p. 23). When you assign an “A” marker and “B” marker in the file, playback will repeat between the “A” and “B” markers. Pressing the button the first time assigns the “A” marker, and pressing it a second time assigns the “B” marker.

**[MARK] button**  
For a WAV file, you can press this button to add a mark at a desired location (p. 23). If you press this button at a marked location, the mark is removed.

**[▶/||] button**  
Press this button to start playback, or to pause playback or recording.  
This button also moves the cursor upward in the screen, or changes the value of the selected item.

**[◀◀] button**  
Press this button to move to the beginning of the file, or to select the previous file. For a WAV file that contains marks, this button returns to the previous mark. By holding down this button, you can rewind through the file.  
You can do this during playback or while stopped.  
This button also moves the cursor to the left in the screen, or changes the value of the selected item.

**INPUT [+/-] buttons**  
These buttons adjust the level of the audio that’s being input via the built-in mics or the MIC/AUX IN jack.  
Pressing [+] will increase the input level. Pressing [-] will decrease the input level.  
You can change the playback speed by pressing these buttons during playback (p. 24).

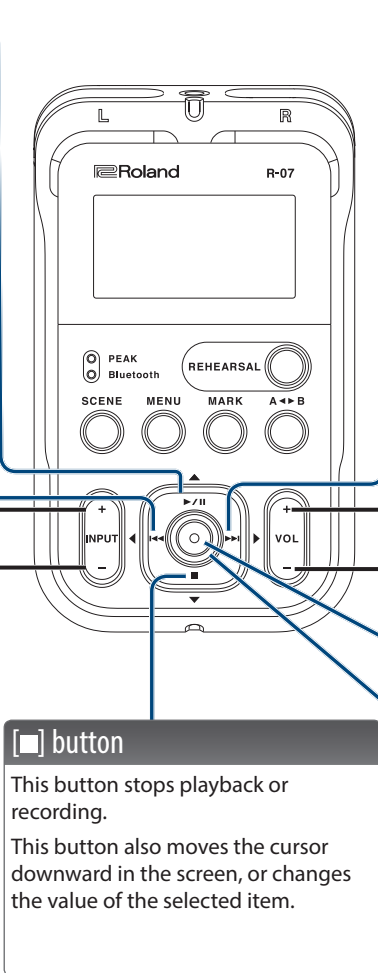

**[▶▶] button**  
Press this button to select the next file. For a WAV file that contains marks, this button advances to the next mark. By holding down this button, you can fast-forward through the file.  
You can do this during playback or while stopped.  
This button also moves the cursor to the right in the screen, or changes the value of the selected item.

**VOL [+/-] buttons**  
These buttons adjust the volume that is output from the built-in speaker, the PHONES jack or the Bluetooth device.

**[●] button**  
Press this button to enter recording-standby mode or to begin recording. You’ll also use this button to confirm a selection.

**REC/PLAY indicator**

Operation	Status
Lit red	Recording
Blinking red	Record-standby
Lit green	Playing
Blinking green	Play-standby

**MIC/AUX IN jack**

Use this if you want to connect an external mic, audio device or electronic musical instrument.

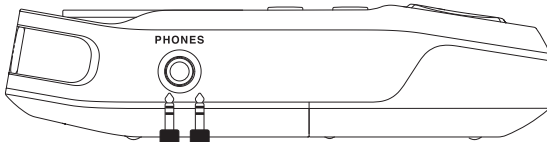
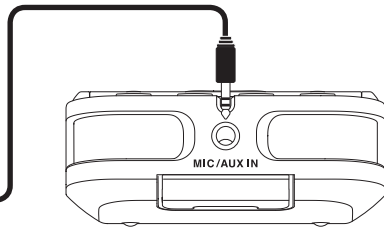

**PHONES jack**

You can connect headphones here (p. 10).

**[POWER] switch**

Slide this switch toward POWER to turn the power on/off (p. 6). With the power turned on, you can set this switch to the right to enable the HOLD function.

If you leave HOLD on, operation is disabled for all buttons, preventing unintended operation. Even if HOLD is on, you can still operate the R-07 from a mobile device (p. 26).

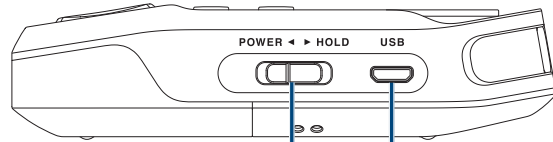

**USB port**

Use a commercially available USB cable to connect this to your computer. This allows files recorded on the R-07 to be transferred to your computer, or WAV and MP3 files from your computer to be copied to the R-07 for playback.

\* Do not use a micro USB cable that is designed only for charging a device. Charge-only cables cannot transmit data.

**microSD card slot**

Insert the microSD card into this slot. When the R-07 is shipped from the factory, a microSD card is inserted.

**Built-in speaker**

This is the R-07's internal speaker.

**Battery compartment**

Install batteries here (p. 6).

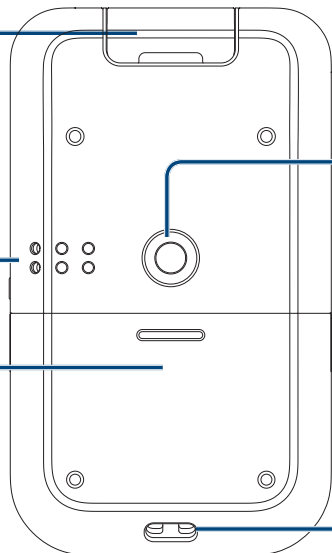

**Tripod mounting socket**

This socket lets you attach the R-07 to a commercially available camera tripod.

(The socket is threaded for a 1/4" screw.)

**Strap hole**

The strap can be passed through this hole.

**About microSD cards**

\* Some memory card types or memory cards from some manufacturers may not record or play back properly on the unit.

# Main Screen

Here we'll explain the principal icons and information shown in the main screen.

## Playing / Stopped

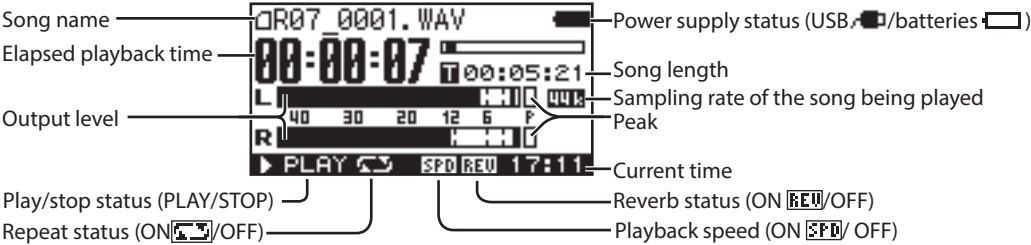

## Recording

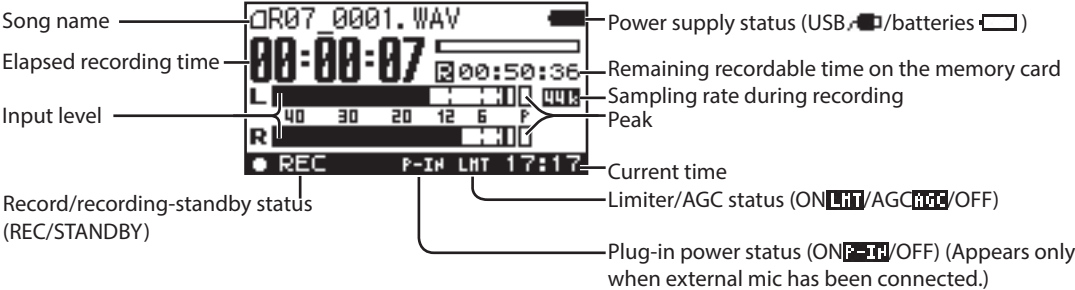

# Getting Ready

## Installing the Batteries

### Types of batteries that can be used

- Alkaline battery (AA, LR6)
- Rechargeable Ni-MH battery (AA, HR6)

#### NOTE

The R-07 itself is not able to recharge rechargeable Ni-MH batteries. You'll need to use a battery charger designed for rechargeable Ni-MH batteries.

### 1. Make sure that the power is off.

If the power is on, turn it off. Slide the R-07's [POWER] switch toward POWER to turn the power on/off.

### 2. Open the cover of the battery compartment located on the bottom of the unit.

Turn the R-07 over, then slide the cover downward while pressing the area circled in the illustration.

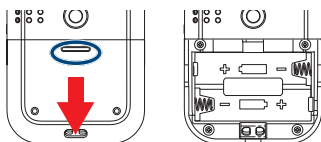

\* When turning the unit over, be careful so as to protect the buttons and knobs from damage. Also, handle the unit carefully; do not drop it.

### 3. Install the batteries.

Install two AA batteries in the compartment, making sure that the polarity (+/- orientation) is correct.

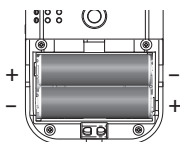

### 4. Close the cover of the battery compartment.

## Supplying Power from the USB Port

### 1. Connect a commercially-available USB AC adaptor and commercially-available USB cable to the R-07.

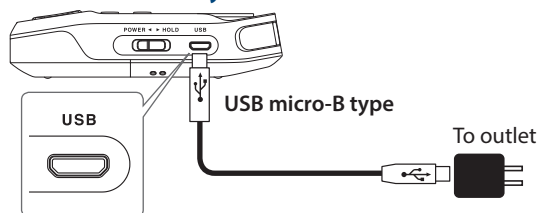

If batteries are installed, the power supplied from the USB port is used, and the batteries are not depleted.

## Turning the Power On/Off

### 1. Slide the [POWER] switch toward POWER for several seconds; the power will turn on.

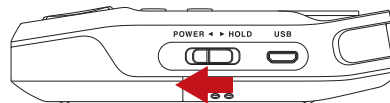

### 2. If the Select USB Mode screen appears, use [▶/II]/[■] to select "Power Supply," and press [●].

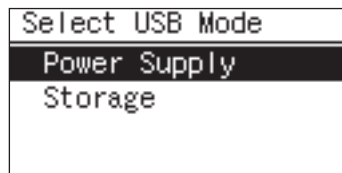

A screen like the following will appear in the display. We'll call this the "main screen."

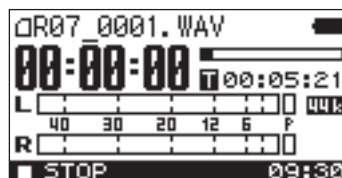

### 3. To turn the power off, slide the [POWER] switch once again toward POWER for several seconds.

## Note when using the R-07 on batteries

- If you handle batteries improperly, you risk explosion and fluid leakage. Make sure that you carefully observe all of the items related to batteries that are listed in "USING THE UNIT SAFELY" and "IMPORTANT NOTES" (leaflet "USING THE UNIT SAFELY").
- Do not mix fresh batteries with used batteries, and do not mix batteries of different types.
- If you won't be using the R-07 for an extended period of time, we recommend that you remove the batteries to prevent them from leaking electrolyte.
- If electrolyte should leak from the batteries, use a soft cloth to wipe the battery compartment clean, and then install new batteries. Electrolyte that contacts your skin might cause irritation. Electrolyte that enters your eyes is dangerous; if this occurs, immediately flush your eyes thoroughly with water.
- Do not carry or store batteries together with metallic objects such as pens, necklaces, or hairpins.

## Power conservation function

The power to this unit will be turned off automatically after a predetermined amount of time has passed since it was last used for playing music, or its buttons or controls were operated (Auto Off function).

If you do not want the power to be turned off automatically, disengage the Auto Off function. For details, refer to the "Auto Off" (p. 40).

- To restore power, turn the power on again.

## Remaining battery indication

- When the remaining battery power runs low, a battery low icon  appears in the upper right of the display. When this appears, install fresh batteries as soon as possible. If you continue to use the unit in this state, the display will indicate "Battery Low," and finally the R-07 will stop functioning entirely.

## Battery life (when using alkaline batteries)

Continuous playback	approximately 15 hours
Continuous recording	approximately 15 hours

- \* The above battery lifespans are approximate. Battery life will vary depending on environmental conditions and the method of use.

## Specifying the Battery Type

1. Press [MENU] to access the "Menu" screen, use  $\blacktriangleright$  /  $\blacksquare$  /  $\blacktriangleleft$  to select "Power Manage," and then press  $\bullet$ .
2. Use  $\blacktriangleright$  /  $\blacksquare$  /  $\blacktriangleleft$  to move the cursor to the Battery setting, and use  $\blacktriangleleft$  /  $\blacktriangleright$  to specify the type of battery that you're using.

Power Manage	
Auto Off:	30min
Battery:	<b>ALKALINE</b>

(Default in bold)

Battery	<b>ALKALINE</b>
	Ni-MH

3. Press [MENU] twice to return to the main screen.

## Setting the Date and Time

After you turn on the power for the first time, you'll need to set the internal clock as follows. The date and time you specify are used as the time stamp for the files that are recorded.

1. Press [MENU] to access the "Menu" screen, use  $\blacktriangleright$  /  $\blacksquare$  /  $\blacktriangleleft$  to select "Date & Time," and then press  $\bullet$ .

### NOTE

- The internal clock is powered by batteries. If the R-07 is left for several minutes with batteries removed, the internal clock will return to its default state. When you turn on the power in this state, the message "Clock Initialized" will appear.
- If the screen indicates "Clock Initialized," you'll need to reset the date and time.

2. Set the date and time.

Use  $\blacktriangleleft$  /  $\blacktriangleright$  to move the cursor left/right.

Date & Time
<b>2017</b> -10-17(TUE)
(YYYY-MM-DD)
11:02:00
Set, Push [REC]

When the cursor is at the position of the character you want to change, use  $\blacktriangleright$  /  $\blacksquare$  /  $\blacktriangleleft$  to change the date and time, and then press  $\bullet$  to confirm the setting.

3. Press [MENU] to return to the main screen.

## Preparing a microSD Card

## Inserting a microSD Card

### Inserting

#### 1. Make sure that the power is off.

If the power is on, turn it off.

#### 2. Open the microSD cover located at the top of the unit.

Insert your fingernail into the notch in the microSD cover, and pull it upward.

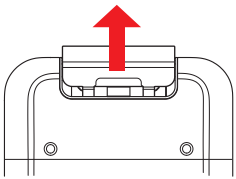

The cover may break if you use excessive force.

#### 3. Insert the microSD card.

Insert the microSD card in the same orientation as shown in the illustration.

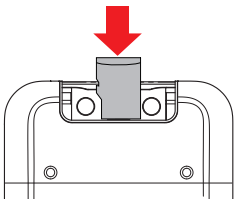

#### NOTE

- Forcibly inserting the microSD card in the wrong orientation may damage the R-07 or the microSD card. Please use caution.
- Press the microSD card firmly all the way in.
- Since a microSD card is small, take care not to lose it when it is ejected.

#### 4. Close the microSD cover.

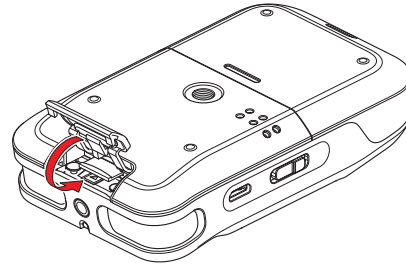

#### 5. Slide the [POWER] switch toward POWER for several seconds to turn on the power.

#### MEMO

If an unformatted microSD card is inserted in the R-07, the screen will indicate "SD Unformatted."

### Removing a microSD card

#### 1. Switch off the R-07's power.

#### 2. Open the microSD cover.

#### 3. Gently press the microSD card inward, and then release your finger.

When the microSD card pops out, remove it.

#### NOTE

Do not insert or remove a microSD card while the power is on. The data on the microSD card may be lost if you do so.

### About microSD cards

#### NOTE

- The R-07 supports microSD/microSDHC cards.
- Some microSD card types or memory cards from some manufacturers may not record or play back properly on the R-07.
- Never insert or remove an microSD card while this unit's power is on. Doing so may corrupt the unit's data or the data on the microSD card.
- Carefully insert the microSD card all the way in—until it is firmly in place.

## Formatting a microSD Card

“Formatting” is the process of preparing the microSD card for use. If you’re using a microSD card other than the included one, you must first format the microSD card before it can be used with the R-07.

### NOTE

- You must format the microSD card on the R-07 itself. A microSD card formatted on a device other than the R-07 might not work correctly in the R-07.
- When you format a microSD card, all data on the card will be erased.

### 1. Make sure that the microSD card you want to format is inserted in the microSD card slot.

For details, refer to “Inserting a microSD Card” (p. 8).

### 2. Press [Menu] to access the “Menu” screen, use [▶/II]/[■] to select “SD Card,” and then press [●].

### MEMO

If you decide to cancel without formatting, press [MENU]. You will return to the previous screen.

### 3. Use [▶/II]/[■] to select “Format,” and then press [●].

### 4. When the confirmation screen appears, use [▶▶] to select “Yes” and then press [●].

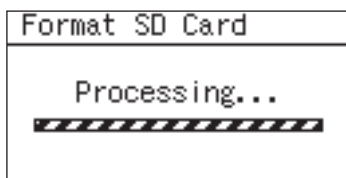
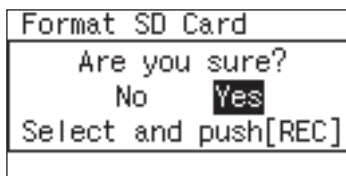

### NOTE

Never remove the microSD card while the screen indicates “Processing.” Doing so may destroy the memory area in the microSD card.

When the screen indicates “Completed!” the formatting process is finished.

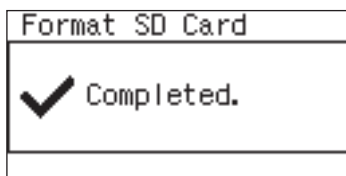

### 5. Press [MENU] twice to return to the main screen.

## Using Headphones or Speakers

The R-07 has a built-in speaker. You can listen to the playback through this speaker, or you can connect headphones or speakers for listening. You can also connect Bluetooth headphones or speakers to the R-07 and listen wirelessly to the playback.

\* To prevent malfunction and equipment failure, always turn down the volume, and turn off all the units before making any connections.

## Connecting External Speakers

\* Turn on power to your various devices in the order specified. By turning on devices in the wrong order, you risk causing malfunction and/or damage to external speakers and other devices.

1. Switch off the R-07's power.
2. Minimize the volume of the external speakers you'll be connecting, and turn off their power.
3. Connect the external speakers.
 

You'll need to use speakers that have a built-in amplifier. Use an audio cable to connect the R-07's PHONES jack to the line input jacks of your speaker system.
4. Switch on the R-07's power.
5. Switch on power to the external speakers, and gradually increase the volume to an appropriate level.

## Connecting Bluetooth® Speakers or Headphones

Supported codecs: SBC, Qualcomm®aptX™ audio, Qualcomm®aptX™ Low Latency audio

### Registering a Bluetooth device (Pairing)

"Pairing" is the procedure by which the mobile device that you want to use is registered on this unit (the two devices recognize each other).

Once a mobile device has been paired with this unit, there is no need to perform pairing again. After the R-07 starts, it searches for the previously-connected device, and connects automatically.

1. Place the Bluetooth device that you want to connect near the R-07, power-on the device, and put it in pairing mode.
 

For details, refer to the owner's manual of your Bluetooth device.
2. Press [MENU] to access the "Menu" screen, use [▶/II]/[■] to select "Bluetooth," and then press [●].
3. Use [▶/II]/[■] to select "Pairing Audio" and then press [●].

4. Use [◀◀]/[▶▶] to choose "Yes," and then press [●].

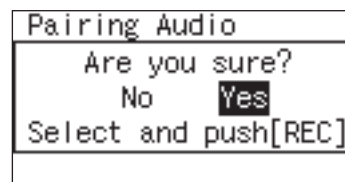

The display indicates "Pairing...," and this unit waits for a response from the Bluetooth device. You can press [■] to cancel the operation.

When pairing succeeds, the display indicates "Completed," and sound can be output from the Bluetooth device.

### Connecting an already-paired Bluetooth device

#### MEMO

If you initialize the settings (p. 40), the existing pairing information is erased. You'll need to pair your device again.

1. Press [MENU] to access the "Menu" screen, use [▶/II]/[■] to select "Bluetooth," and then press [●].
2. Use [▶/II]/[■] to select "Connect Audio" and then press [●].
3. Select the playback device and press [●].

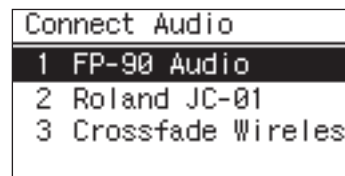

4. Use [◀◀]/[▶▶] to choose "Yes," and then press [●].

The display indicates "Connecting...," and this unit waits for a response from the Bluetooth device. You can press [■] to cancel the operation.

When pairing succeeds, the display indicates "Completed," and sound can be output from the Bluetooth device.

### Checking which Bluetooth device you're connected to

1. Press [MENU] to access the "Menu" screen, use [▶/II]/[■] to select "Bluetooth," and then press [●].
2. Use [▶/II]/[■] to select "Information" and then press [●].

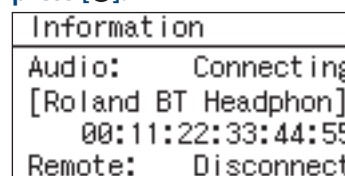

3. Press [MENU] three times to return to the main screen.

## Disconnecting a Bluetooth device

Use this procedure when you want to switch to a different Bluetooth device.

1. Press [MENU] to access the "Menu" screen, use [▶/II]/[■] to select "Bluetooth," and then press [●].
2. Use [▶/II]/[■] to select "Disconnect Audio" and then press [●].
3. Use [◀◀]/[▶▶] to choose "Yes," and then press [●].

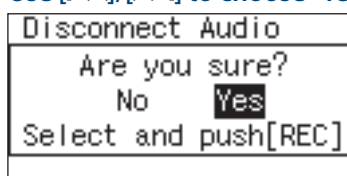

When disconnection succeeds, the display indicates "Completed."

# Recording

## Basic Recording Operation

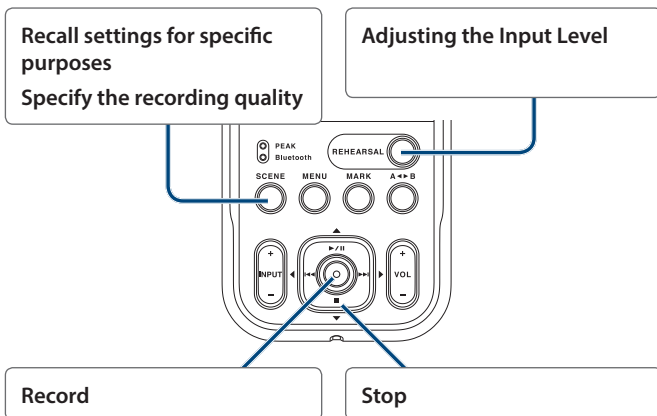

### 1. Switch on the R-07's power (p. 6).

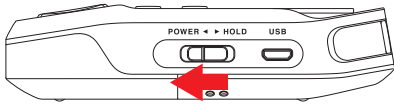

### 2. Recall the settings that are most appropriate for your specific recording situation (p. 13).

### 3. Specify the audio quality of the recording (p. 14).

### 4. Adjust the recording level (p. 17).

### 5. Start recording.

If the REC/PLAY indicator is unlit, press [●] to make it blink red, putting the unit in recording-standby mode.

In recording-standby mode, press [●] or [▶/||]; the REC/PLAY indicator is lit red, and recording starts.

#### MEMO

After recording starts, you can set the [POWER] switch to the HOLD position so that accidental button presses do not stop the recording or change the input level.

#### NOTE

- The built-in mics cannot be used if a mic or other device is connected to the MIC/AUX IN jack. If you want to use the built-in mics, do not connect anything to the MIC/AUX IN jack.
- The recording level will change if you operate the INPUT [+]  
[-] buttons in recording-standby mode or during recording. Take care that you don't inadvertently operate the INPUT [+]  
[-] buttons.
- You can't turn off the power during recording. You must stop recording before you can turn off the power.

### 6. Press [■] to stop recording.

The REC/PLAY indicator will go out.

The display will show the file that was recorded (p. 5).

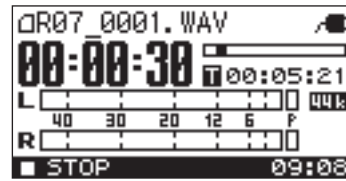

#### MEMO

- To pause, press [▶/||]. To disengage pause and resume recording, press [▶/||] once again.
- A file name such as R07\_0001.WAV will be created automatically. The 0001 portion is assigned as a number that is one greater than the largest number of the existing files.
- If the Recorder parameter File Name is set to "Date," the date and time of recording will be the file name. For details, refer to "File Name" (p. 39).

### 7. Press [▶/||] to play back the recorded file.

For details, refer to "Basic Playback Operation" (p. 22).

## Recalling Settings for Specific Purposes

The R-07 provides settings that are suitable for various recording situations. These settings are called “scenes.”

### 1. Press [SCENE] to access the “Scene” screen, and use [◀◀]/[▶▶] to change the Scene setting.

Scene	Explanation	Sample Rate	Rec Mode	Limiter	Low Cut	Input Level
OFF	Choose this if you want to make settings manually.					
Music HiRes	Settings appropriate for high-quality recording of a band performance that’s not high-volume, or of an acoustic instrumental performance.	96 kHz	WAV-24 bit	ON	OFF	60
Music CD	Settings for CD-quality recording.	44.1 kHz	WAV-16 bit	ON	OFF	60
Music Long	Settings for extended-duration recording.	44.1 kHz	MP3-192 kbps	ON	OFF	60
Loud Live	Settings appropriate for high-volume performances such as in a club.	44.1 kHz	WAV-24 bit	OFF	OFF	25
Loud Practice	Settings appropriate for extended-duration recording at high volume, such as in a practice studio.	44.1 kHz	MP3-192 kbps	OFF	OFF	25
Instrument	Settings appropriate for recording a nearby instrument.	44.1 kHz	WAV-24 bit	ON	OFF	60
Vocal	Settings appropriate for recording a nearby vocal.	44.1 kHz	WAV-24 bit	ON	100 Hz	60
Voice Memo	Settings appropriate for non-musical recording, such as a conference, lecture, or speech.	44.1 kHz	MP3-128 kbps	AGC	200 Hz	AUTO
Field	Settings appropriate for recording the sounds of nature, such as birdcalls or the murmuring sound of a river.	96 kHz	WAV-24 bit	ON	100 Hz	80

Even after selecting a scene, you can edit the Sample Rate (p. 14), Rec Mode (p. 14), Limiter (p. 16), Low Cut (p. 16), and Input Level (p. 17) values.

## Saving an Edited Scene

Here’s how to save a scene that you’ve edited.  
Scenes other than “OFF” can be saved.

1. Press [SCENE] to access the “Scene” screen.
2. Use [▶/II]/[■] to select “Store Scene” and then press [●].

Limiter:	OFF
Low Cut:	OFF
Input Level:	35
Store Scene	
Initialize Scene	

3. When the confirmation screen appears, use [▶▶] to select “Yes” and then press [●].

## Initializing an Edited Scene

After you’ve edited a scene, here’s how to initialize it to the original settings.

Scenes other than “OFF” can be initialized.

1. Press [SCENE] to access the “Scene” screen.
2. Use [▶/II]/[■] to select “Initialize Scene” and then press [●].

Limiter:	OFF
Low Cut:	OFF
Input Level:	35
Store Scene	
Initialize Scene	

3. When the confirmation screen appears, use [▶▶] to select “Yes” and then press [●].

## Specifying the Recording Quality

You can specify the audio quality with which the recording will be made.

The audio quality setting is a combination of the Sample Rate (sampling rate) and the Rec Mode. The audio quality will affect the size of the file, and will also affect the length of time over which recording can take place with an microSD card.

Consider whether audio quality or length of recording are more important for your situation, and choose the quality that's appropriate for you.

### Sample Rate

(Default in bold)

Sample Rate	44.1 kHz
	48.0 kHz
	88.2 kHz
	<b>96.0 kHz</b>

Higher sampling rates will provide higher audio quality. You'll need to use a high sampling rate if you want to accurately reproduce the high-frequency range.

**MEMO**

- Higher sampling rate settings will increase the size of the file, and will shorten the available recording time.
- If you are recording audio material that you'll be editing into a video production, we recommend that you use the 48.0 kHz sampling rate.
- The R-07 is not able to convert the sampling rate of a recorded file.

**NOTE**

- If this setting is 88.2 kHz or 96.0 kHz, the only choices for Rec Mode are WAV-16 bit and WAV-24 bit.

### Rec Mode

(Default in bold)

Rec Mode	2xWAV-16bit
	2xWAV-24bit
	WAV+MP3
	MP3-64kbps
	MP3-96kbps
	MP3-128kbps
	MP3-160kbps
	MP3-192kbps
	MP3-224kbps
	MP3-320kbps
	WAV-16bit
	<b>WAV-24bit</b>

WAV files allow higher-quality recording than MP3 files.

If you choose MP3, the file size will be smaller than WAV, allowing you to record for a longer length of time. Higher settings for "bit" or "bps" will increase the file size, shortening the available recording time.

WAV+MP3 simultaneously creates both a WAV file and an MP3 file.

**MEMO**

- Some software such as Windows Media Player cannot play back 24-bit WAVE files.

**NOTE**

- 2xWAV-16 bit, 2xWAV-24 bit, MP3 and WAV+MP3 can be selected only if the Sample Rate is 44.1 kHz or 48.0 kHz.
- If you select WAV+MP3, the setting is fixed at WAV-16 bit and MP3-128 kbps.

### Examples of formats used for music

Purpose	Rec Mode	Approximate size
Professional quality	WAV 24 bit/48 kHz	approx. 20 MB per minute
Creating a music CD on your computer	WAV 16 bit/44.1 kHz	approx. 10 MB per minute
Distributing music on the Internet	MP3 128 kbps/44.1 kHz	approx. 1 MB per minute

## Setting the Sample Rate and Rec Mode

- Press [SCENE] to access the "Scene" screen.
- Use [▶/II]/[■] to move the cursor to Sample Rate setting, and use [◀◀]/[▶▶] to change the setting.

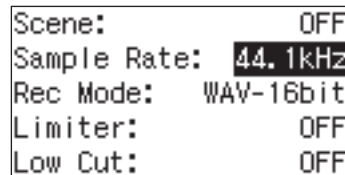

- Use [▶/II]/[■] to move the cursor to Rec Mode setting, and use [◀◀]/[▶▶] to change the setting.

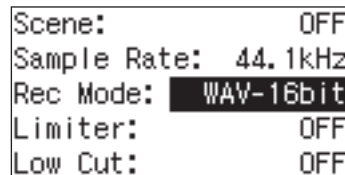

- Press [SCENE] to return to the main screen.

### 2xWAV (Dual level recording)

By choosing 2xWAV- as the Rec Mode, you can simultaneously record at the specified input level (p. 17) and at an input level approximately 20 dB lower than that input level. This setting is recommended if there is a possibility that the recorded sound might distort when the volume during actual recording is louder than you expected.

When you record, two files are created. The examples below are for when the file name is R07\_0010.WAV.

R07_0010.WAV	Recorded at the specified input level
R07_0010L.WAV	Recorded at an input level 12 dB lower than the specified level

## Approximate Recording Times

The following table shows the approximate recording times that a microSD card will allow.

Recordable time (approximate)		Units: minutes				
		microSD card capacity				
Rec Mode		2 GB	4 GB	8 GB	16 GB	32 GB
WAV	WAV (24 bit/96 kHz)	55	110	220	450	900
	WAV (24 bit/88.2 kHz)	60	120	240	490	980
	WAV (24 bit/48 kHz)	110	220	440	900	1800
	WAV (24 bit/44.1 kHz)	120	240	480	980	1950
	WAV (16 bit/96 kHz)	80	160	320	670	1350
	WAV (16 bit/88.2 kHz)	88	176	352	735	1470
	WAV (16 bit/48 kHz)	166	332	664	1350	2700
	WAV (16 bit/44.1 kHz)	180	360	720	1470	2950
MP3	MP3 (320 kbps)	797	1540	3080	6450	12950
	MP3 (128 kbps)	1993	3990	7980	16180	32350
WAV+MP3	WAV (16 bit/48 kHz)+MP3 (128 kbps/48 kHz)	152	305	610	1240	2490
	WAV (16 bit/44.1 kHz)+MP3 (128 kbps/44.1 kHz)	165	330	660	1345	2690
WAVE x2 (2xWAV)	WAV (24 bit/48 kHz)	55	110	220	450	900
	WAV (24 bit/44.1 kHz)	60	120	240	490	975
	WAV (16 bit/48 kHz)	83	166	332	675	1350
	WAV (16 bit/44.1 kHz)	90	180	360	735	1475

### NOTE

- The recording times listed above are approximate. They may differ depending on the specifications of the card. If multiple files are recorded, the total recording time may be less than these listed times.
- The maximum recordable size of a single file is 2 GB.

## Using Limiter or AGC

The limiter setting gives you three choices: "ON" to use the limiter, "AGC" to use Auto Gain Control, or "OFF" to use neither. Normally you'll choose "OFF."

The Limiter is a function that compresses the recording level when the input sound becomes too loud, thus preventing distortion.

AGC increases the recording level if the input is low, and decreases the level if the input is too high, thus recording at a consistent level. This allows recording at a consistent volume during a meeting that might include people who are distant or nearby, and both loud voices and soft voices.

If you record music or an instrumental performance with the limiter set to "ON" or "AGC," the varying dynamics of the performance will be recorded at a consistent level, impairing the musical expressiveness. If you want to record the sound with its natural dynamics intact, leave the Limiter turned "OFF."

**NOTE**

- You can't adjust the input level if Limiter is "AGC."
- You can't use the rehearsal function if Limiter is "AGC."

## Setting the Limiter

1. Press [SCENE] to access the "Scene" screen.
2. Use [▶/II]/[■] to move the cursor to Limiter setting, and use [◀◀]/[▶▶] to change the setting.

```
Sample Rate: 44.1kHz
Rec Mode: WAV-16bit
Limiter: OFF
Low Cut: OFF
Input Level: 35
```

(Default in bold)

Limiter	OFF
	<b>ON</b>
	AGC

3. Press [SCENE] to return to the main screen.

**NOTE**

If Limiter is "AGC," INPUT [+/-] is disabled, and you won't be able to adjust the recording level manually.

## Cutting the Low-Frequency Range

If low cut is set to anything other than "OFF," the low-frequency range below the specified frequency is cut. Normally you'll choose "OFF."

If you have problems with low-frequency noise, such as the wind noise that is often present in outdoor recordings, the rumble from automobiles or machines, or vibration, you may be able to reduce this noise by cutting the low-frequency range.

If you have problems with the breath noise or muffled tone that can occur when recording a vocal, cutting the low-frequency range will give you a more crisp recording.

## Setting the frequency at which to cut

1. Press [SCENE] to access the "Scene" screen.
2. Use [▶/II]/[■] to move the cursor to Low Cut setting, and use [◀◀]/[▶▶] to change the setting.

```
Sample Rate: 44.1kHz
Rec Mode: WAV-16bit
Limiter: OFF
Low Cut: OFF
Input Level: 35
```

(Default in bold)

Low Cut	<b>OFF</b>
	100 Hz
	200 Hz
	400 Hz

3. Press [SCENE] to return to the main screen.

## Adjusting the Input Level

The R-07 is designed to let you record a wide range of sounds. By adjusting the input level (volume) appropriately for the source you're recording, you'll be able to record with optimal quality.

The basic principle when adjusting the level is to get the level as high as possible without allowing distortion to occur. This principle applies whether you're using the built-in mics, an external mic, or AUX IN.

## Manually Adjusting the Input Level

### NOTE

You can't adjust the recording level if Limiter (p. 16) is "AGC."

**1. Point the R-07's mics toward the source you'll be recording.**

**2. In the main screen, press [●] so the REC/PLAY indicator is blinking red.**

The R-07 is in recording-standby mode.

**3. On the audio source you'll be recording, play the sounds that you actually intend to record.**

The level meter will move according to the loudness of the sound being input to the R-07.

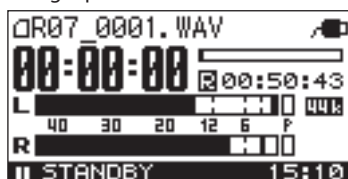

If you're going to record a musical performance such as an instrument or vocal, you should play the loudest passage of the song.

**4. While the sound plays, use INPUT [+] [-] to adjust the recording level a little at a time.**

### MEMO

If the recording mode is set to 2xWAV- (dual-level recording), the input level cannot be set to a value of 1–41.

The higher the level at which the sound is being captured, the farther toward the right the level meter will move. Use INPUT [+] [-] to adjust the level so that the sound is captured at as high a level as possible.

However, don't allow the PEAK indicator to light; this indicates that the input volume is excessive.

If the PEAK indicator lights, this means that the input has exceeded the maximum volume that can be recorded by the R-07; i.e., the input is "clipping." Sound that's recorded in this condition will be distorted.

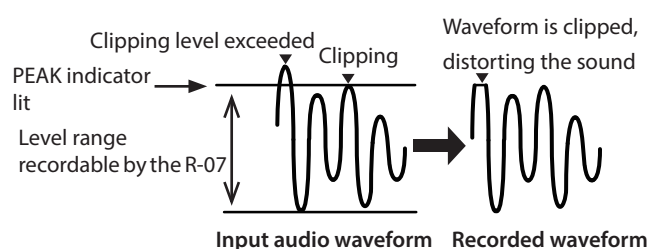

Use INPUT [+] [-] to adjust the level so that even the loudest passages do not cause the PEAK indicator to light; i.e., so that clipping does not occur. If you're recording a song, make sure that clipping does not occur during the climax of a vocal or during a fortissimo passage of an instrumental performance.

**5. When you've finished adjusting the level, press [●] to start recording.**

### MEMO

- To stop recording, press [■]; you'll return to the main screen. The level setting will be preserved, so you can press [●] once again to start recording at the same recording level.
- When using the INPUT [+] [-] buttons, you might hear a slight noise when the input level changes; this does not indicate a malfunction.

## Using the Rehearsal Function

You can use the rehearsal function to automatically set the appropriate recording level based on the audio that is input during the specified length of time.

**NOTE**

You can't use the rehearsal function if Limiter (p. 16) is "AGC."

1. Press [MENU] to access the "Menu" screen, use [▶/II]/[■] to select "Input," and then press [●].
2. Use [▶/II]/[■] to move the cursor to Rehearsal Time setting, and use [◀◀]/[▶▶] to change the setting.

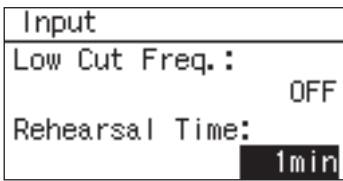

(Default in bold)

Rehearsal Time	Manual
	30 sec
	<b>1 min</b>
	3 min
	5 min

3. Press [MENU] twice to return to the main screen.
4. Point the mic toward the source you want to record, and press [REHEARSAL].



The input level will automatically be set according to the loudest volume that occurs during the specified Rehearsal Time. At the same time, the unit will also perform a test to determine the appropriate sensitivity for the mic. When the setting is completed, the R-07 will return to the main screen.

If the Rehearsal Time is set to "Manual," press [■] to finish the rehearsal.

If you're going to record a musical performance such as an instrument or vocal, you should play the loudest passage of the song.

## Using the Pre-Rec Function

The R-07 provides a Pre-Rec function that lets you capture the two seconds of sound that preceded the moment you press [●]. Even for situations in which you're not sure when the desired sound will begin, such as when recording outdoors, this function ensures that you can record without missing the first moments of the sound.

1. Press [MENU] to access the "Menu" screen, use [▶/II]/[■] to select "Recorder," and then press [●].
2. Use [▶/II]/[■] to move the cursor to Pre-Rec setting, and use [◀◀]/[▶▶] to change the setting to "ON."

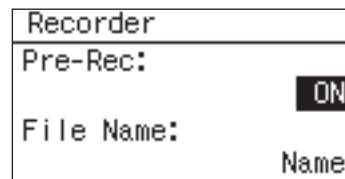

3. Press [MENU] twice to return to the main screen.

## Using the Auto Rec Start Function

By using the Auto Rec Start function, you can have recording start automatically when a specified time has elapsed, or when the input level exceeds a specified value.

1. Press [MENU] to access the "Menu" screen, use [▶/II]/[■] to select "Recorder," and then press [●].
2. Use [▶/II]/[■] to move the cursor to Auto Rec Start setting, and use [◀◀]/[▶▶] to specify the time after which recording will start or the level at which recording will start.

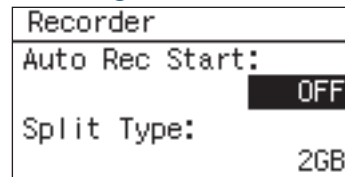

(Default in bold)

Auto Rec Start	<b>Auto Rec Start is not used</b>	<b>OFF</b>
	Time until recording starts	2 sec
		5 sec
		10 sec
	Level at which recording starts	Level1 (-60 dB)
		Level2 (-30 dB)
Level3 (-20 dB)		

3. Press [MENU] twice to return to the main screen.
4. From the main screen, press [●] so the REC/PLAY indicator is blinking red.  
The R-07 will enter recording-standby mode.
5. Press [●] once again.

Recording will begin automatically when the specified time has elapsed or when the specified input level is detected.

## Recording Instruments or Vocals

### Using the Built-in Mics

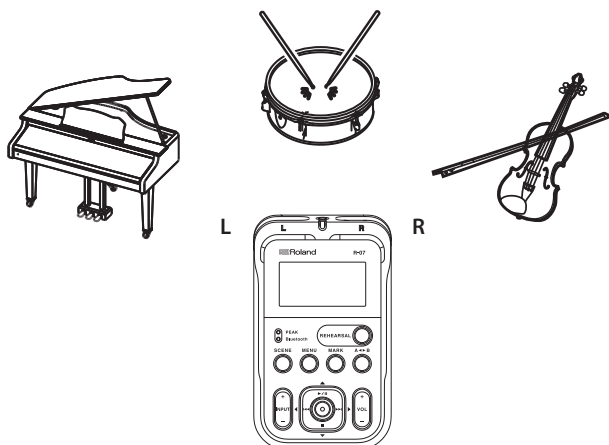

The built-in mics are stereo.

The mic on the right side of the R-07 will record the right (R) channel, and the mic on the left side will record the left (L) channel.

#### NOTE

- To avoid acoustic feedback (a whine or howling sound), do not connect external speakers when you're recording via a mic.
- The built-in mics cannot be used if a mic or device is connected to the MIC/AUX IN jack. If you want to use the built-in mics, don't connect anything to the MIC/AUX IN jack.

#### MEMO

If you're using headphones to monitor (listen to) the sound while it's being recorded, turn the Rec Monitor SW "ON."

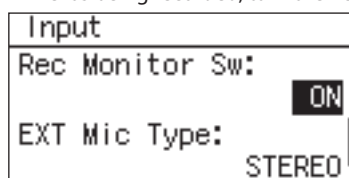

For details, refer to "Settings for the R-07" (p. 38).

### Using an External Mic

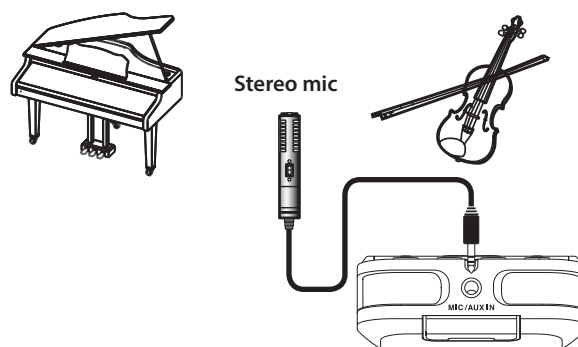

A dynamic mic or a condenser mic of the type designed for connection to a computer's mic jack can be used with the R-07.

#### NOTE

- To avoid acoustic feedback (a whine or howling sound), do not connect external speakers when you're recording via a mic.
- To prevent malfunction and/or damage to speakers or other devices, always turn down the volume, and turn off the power on all devices before making any connections.

### Settings for the type of mic you're using

#### External mic type setting

Here's how to switch the mono/stereo setting as appropriate for the mic that's connected to the MIC/AUX IN jack.

#### MEMO

If you're using a mono mic, and record with the external mic type set to "STEREO," only the L channel will be recorded. If you use the "MONO" setting, the same sound will be recorded on the L and R channels.

1. Press [MENU] to access the "Menu" screen, use [▶/II]/[■] to select "Input," and then press [●].
2. Use [▶/II]/[■] to move the cursor to the EXT Mic Type setting, and use [◀◀]/[▶▶] to choose "MONO" or "STEREO."

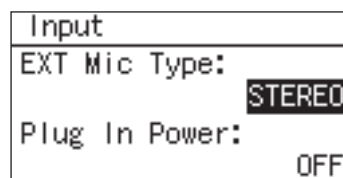

(Default in bold)

EXT Mic Type	<b>STEREO</b>	If the external mic is stereo
	MONO	If the external mic is mono

3. Press [MENU] twice to return to the main screen.

### Plug In Power setting

Turn this setting "ON" if you're using a plug-in powered mic; turn it "OFF" if you're using a mic that uses a battery or does not require a plug-in power supply.

1. Press [MENU] to access the "Menu" screen, use [▶/II]/[■] to select "Input," and then press [●].
2. Use [▶/II]/[■] to move the cursor to the Plug In Power setting, and use [◀◀]/[▶▶] to choose "ON" or "OFF."

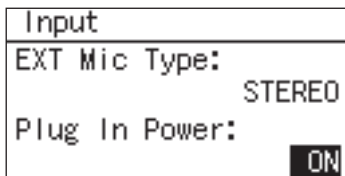

(Default in bold)

Plug In Power	<b>OFF</b>	Dynamic mic, or condenser mic with an internal battery
	ON	ON Plug-in powered condenser mic

**NOTE**

If you've connected a dynamic mic or a mic that has an internal battery, you must turn Plug In Power "OFF." Using the wrong setting may damage your equipment.

3. Press [MENU] twice to return to the main screen.

#### About dynamic mics

This type of mic is rugged, and is suitable for recording vocals and instruments. It does not require a power supply.

#### About condenser mics

This type of mic features high sensitivity, and is suitable for recording lower-level sounds such as acoustic instruments and conferences. It requires power to be supplied from a battery or via plug-in power.

## Recording from a Cassette or CD

In addition to recording instrumental performances or voice memos via a mic, the R-07 lets you use the MIC/AUX IN jack to record sound from a cassette or CD.

**NOTE**

- When connection cables with resistors are used, the volume level of equipment connected to the inputs (MIC/AUX IN) may be low. If this happens, use connection cables that do not contain resistors.
- If you want to record from a connected record player, you'll need to obtain a phono equalizer separately.

In this example, we'll explain how the sound from an CD player can be recorded into the R-07.

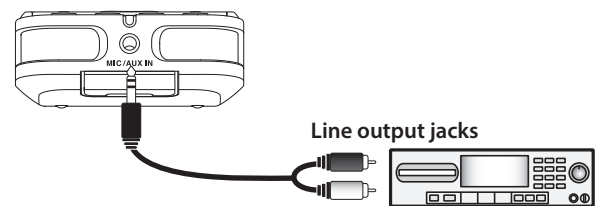

### 1. Connect your CD player.

Use an audio cable to connect your CD player's line output jacks to the R-07's MIC/AUX IN jack.

### 2. Adjust the input level.

Adjust the input level while playing back the desired song on your CD player.

When you've finished adjusting the input level, set your player back to the beginning of the song you'll be recording.

## Assigning a Marker During Recording

You can assign markers in the WAV file during recording.

Once you've assigned markers, you'll be able to jump to the marked locations by touching [◀◀] [▶▶] in the MARK tab during playback.

\* Markers cannot be assigned to an MP3 file.

## Manual Marking

1. Start recording.
2. At the moment you want to assign a marker, press [MARK].
3. Press [■] to stop recording.

To delete an assigned marker, press [MARK] at the location of the marker.

## Splitting the File During Recording

If you've split the file, it will be easy to start playback from a division point.

When you're making a continuous recording for an extended period of time, you may find it desirable to split the project at points that will be convenient for searching.

## Splitting Manually

### MEMO

With the default settings, you can split the file by pressing the [●] button. If you change the "Manual Split" (p. 39) settings, you can also split the file by pressing the [A◀▶B] button.

1. Start recording.
2. At the moment you want to split the file, press [●].  
The file will be split at the point you press the button.
3. Press [■] to stop recording.

## Splitting Automatically

The R-07 can automatically split the file when the currently recorded file reaches a specified size, or when the recording level falls below a specified value.

By default, this is set to automatically split the file when the file size reaches 2 GB.

1. Press [MENU] to access the "Menu" screen, use [▶/II]/[■] to select "Recorder," and press [●].
2. Use [▶/II]/[■] to move the cursor to the Split Type setting, and use [◀◀]/[▶▶] to choose the file size or the recording level at which the file is to be automatically split.

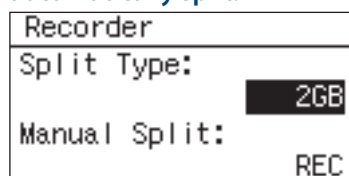

(Default in bold)

Split Type	Size at which file will be automatically split	64 MB
		128 MB
		256 MB
	Recording level at which file will be automatically split	512 MB
		1 GB
		<b>2 GB</b>
	Level 1 (-60 dB)	
	Level 2 (-30 dB)	
	Level 3 (-20 dB)	

3. Press [MENU] twice to return to the main screen.

### NOTE

- With some microSD cards, there are rare cases in which the recording is interrupted.
- When carrying out playback on the R-07, it is not possible to play back without an interruption between the preceding and following files; i.e., gapless playback is not supported.
- File splitting is possible if at least two seconds have been recorded in a file. You cannot split files at intervals less than two seconds.

# Playback

## Basic Playback Operation

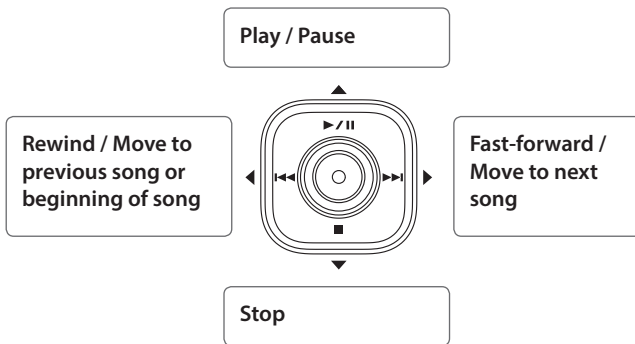

1. Access the main screen.
2. Use [◀◀]/[▶▶] to select the file that you want to play.

### MEMO

If the display indicates “No Song,” the current folder contains no files that the R-07 can play back.  
If the display indicates “No Card,” no microSD card has been inserted.

3. Press [▶/II] to play the file.

The REC/PLAY indicator will light green.

During playback, you can hold down [▶▶] to rewind, or [◀◀] to fast-forward. Normal playback will resume when you release the button.

### NOTE

For some types of microSD card, the data reading speed may not keep up when rewinding or fast-forwarding during playback, causing the rewind or fast-forward operation to stop.

If this occurs, press [■] to stop playback. Then play back once again.

4. Use VOL [+]/[-] to adjust the volume.
5. Press [■] to stop playback.

## Play Mode and Repeat Settings

You can specify how the files will be played. In addition to playing files consecutively from the first file, you can play just the selected file, or play files in an automatically determined order (shuffle play).

1. Press [MENU] to access the “Menu” screen, use [▶/II]/[■] to select “Player,” and then press [●].
2. Use [▶/II]/[■] to move the cursor to Play Mode setting, and use [◀◀]/[▶▶] to change the setting.

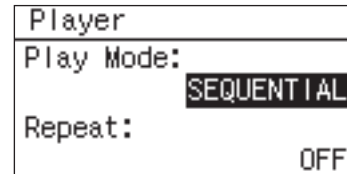

(Default in bold)

Play Mode	SINGLE (play one file)
	<b>SEQUENTIAL</b> (play in order)
	SHUFFLE (shuffle play)

3. Use [▶/II]/[■] to move the cursor to Repeat setting, and use [◀◀]/[▶▶] to turn Repeat ON/OFF.

(Default in bold)

Repeat	<b>OFF</b> (don't play repeatedly)
	ON (play repeatedly)

### MEMO

- The following table shows the possible combinations of these settings.

(Default in bold)

Play Mode	Repeat	Explanation
SINGLE	OFF	Play only one file and then stop
	ON	Play one file repeatedly
<b>SEQUENTIAL</b>	<b>OFF</b>	Play sequentially and then stop
	ON	Play sequentially repeatedly
SHUFFLE	OFF	Shuffle play and then stop
	ON	Shuffle play repeatedly

- If you use “SHUFFLE” with Repeat turned “ON,” the files will play in shuffled order, and then played again in the same shuffled order. If you want to re-shuffle the order, press [■] and then press [▶/II] once again.
- File names starting with “.” are not shown.
- Files having a file name extension of anything other than .WAV or .MP3 are not shown.
- The file names shown in the display do not correspond to the ID3 tags of the MP3 files.

## Assigning Markers in a File

You can assign markers to the desired locations in a WAV file, and then jump easily to those locations.

\* Markers cannot be assigned to an MP3 file.

1. Access the main screen.
2. Use the [▶/II], [■], [◀◀], and [▶▶] to play, fast-forward, or fast-reverse to find the location at which you want to assign a marker.
3. When you've found the location at which you want to assign a marker, press [MARK].

The number of markers will be shown. Markers are numbered sequentially starting at the beginning of the project.

A maximum of 99 markers can be assigned. Repeat steps 2 and 3 to assign markers at the desired locations.

### Moving to a marker

Press [◀◀] to move to the marker that precedes the current location.

Press [▶▶] to move to the marker that follows the current location.

### Deleting a marker

Press [MARK] at a location where a marker is assigned.

## Repeatedly Playing a Portion of a File

The AB Repeat function lets you repeatedly play a specified portion of a file. You can use this to repeatedly hear a section of interest.

1. Press [▶/II] to play the file.
2. Specify the beginning of the repeat (point A).  
During playback, press [A◀▶B]. That point will be the beginning (point A) of the repeated portion.

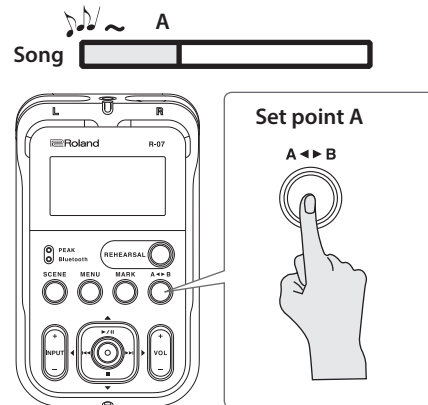

3. Specify the end of the repeat (point B).

Press [A◀▶B] once again. That point will be the end (point B) of the repeated portion.

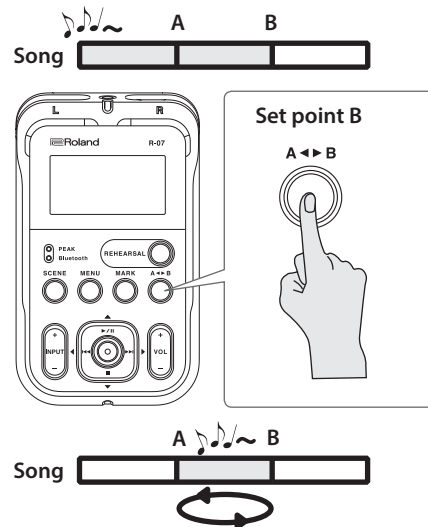

### Cancelling the setting

- If point A and point B are already specified, pressing [A◀▶B] will clear the point A and B settings.
- To stop playback, press [■]. The repeat playback settings (points A and B) will be retained, but playback will stop.

#### MEMO

- If you've set point A and do not set point B before playback reaches the end of the file, playback will repeat between point A and the end of the file.
- The repeat settings will be cancelled if you use [◀◀]/[▶▶] to select another file.

## Changing the Playback Speed

**Not available for 88.2 kHz or 96.0 kHz sample rates**

You can make the playback faster or slower without changing the pitch.

1. Press [MENU] to access the “Menu” screen, use [▶/II]/[■] to select “Player,” and then press [●].
2. Use [▶/II]/[■] to move the cursor to Speed setting, and use [◀◀]/[▶▶] to change the setting.

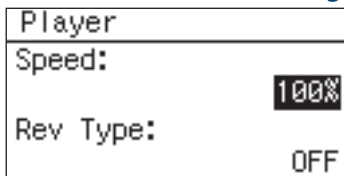

(Default in bold)

Speed	50%
	60%
	70%
	80%
	90%
	<b>100%</b>
	110%
	120%
	130%
	140%
150%	

3. Press [MENU] twice to return to the main screen.

If Speed is other than “100%,” the indication “SPD” is highlighted at the bottom of the screen, and the playback speed changes.

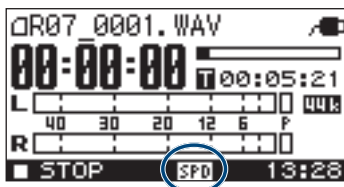

When you set Speed to “100%,” playback returns to the original speed.

**NOTE**

- If the playback speed is other than “100%,” the reverb effect (p. 24) is not applied.
- Changing the playback speed by a large amount will affect the tonal character.
- When you select another file, the playback speed returns to “100%.”

## Using the INPUT [+][–] Buttons to Change the Playback Speed

During playback, you can use the INPUT [+][–] buttons to change the playback speed; the playback speed value is shown.

## Applying Reverb to the Playback

**Not available for 88.2 kHz or 96.0 kHz sample rates**

You can apply reverb when playing back a file on the R-07. The reverb effect simulates the reverberation that is characteristic of a performance in a large hall or other space.

**NOTE**

- You can’t record the sound with reverb applied. Nor can you apply reverb to the monitored sound during recording.
- When you apply the reverb effect, the playback speed (p. 24) is set to “100%.”

## Applying Reverb

1. Press [MENU] to access the “Menu” screen, use [▶/II]/[■] to select “Player,” and then press [●].
2. Use [▶/II]/[■] to move the cursor to Rev Type setting, and use [◀◀]/[▶▶] to change the setting.

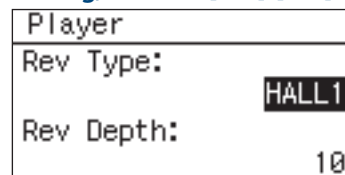

(Default in bold)

Rev Type	<b>OFF</b>	Reverberation is not applied.
	HALL1	Simulates the reverberation of a concert hall. This produces mild, spacious, and long reverberation.
	HALL2	Hall 2 produces a shorter reverberation than Hall 1.
	ROOM	Simulates the reverberation of a room. This produces a bright, short reverberation that is typical of a club or studio.
	PLATE	Simulates the reverberation produced by a plate reverb unit (a reverb device that uses the vibration of a metal plate). This produces a metallic reverberation with an extended high-frequency range.

3. Press [MENU] twice to return to the main screen.

If the reverb type is other than “OFF,” the indication “REV” is highlighted at the bottom of the screen, and the reverb effect is applied.

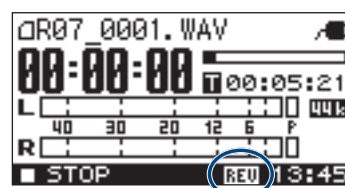

When you set the reverb type to “OFF,” the reverb effect is turned off.

## Changing the Reverb Depth

Specifies the depth of reverb.

1. Press [MENU] to access the "Menu" screen, use [▶/II]/[■] to select "Player," and then press [●].
2. Use [▶/II]/[■] to move the cursor to Rev Depth setting, and use [◀◀]/[▶▶] to change the setting.

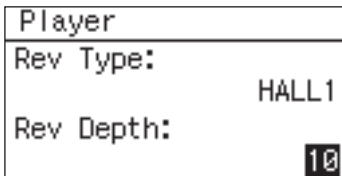

Rev Depth	1-10
-----------	------

3. Press [MENU] twice to return to the main screen.

## Types of Files that Can be Played

The R-07 can play back the following types of files.

	Sampling rate (kHz)	Sample size (bits)
WAV	32.0, 44.1, 48.0, 88.2, 96.0	16, 24

	Sampling rate (kHz)	Bit rate
MP3	32.0, 44.1, 48.0	32-320 kbps, VBR

### What is VBR?

VBR stands for Variable Bit Rate, which uses a lower bit rate when the sound is less dense and a higher bit rate when the sound is more dense.

# Controlling the R-07 from a Mobile Device

Using **Bluetooth**® functionality lets you remotely control the R-07 from a mobile device such as a smartphone or tablet.

\* The app supports iOS and Android.

Here we explain how to install the app and make initial settings.

## Installing the App “R-07 Remote”

1. From the web browser of your mobile device, access the following URL.

<http://roland.cm/r-07>

From the page that appears, install the app that’s appropriate for your mobile device.

## Making Settings on the R-07

1. Press [MENU] to access the “Menu” screen, use [▶/II]/[■] to select “Bluetooth,” and then press [●].
2. Use [▶/II]/[■] to select “Remote Control,” and then press [●].
3. Use [▶/II]/[■] to move the cursor to Remote setting, and use [◀◀]/[▶▶] to turn “ON.”

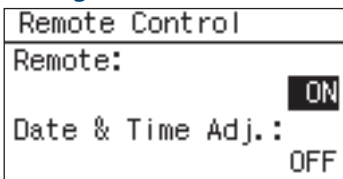

The Bluetooth indicator will light.

4. Press [MENU] three times to return to the main screen.

## Making Settings on the Mobile Device

1. Turn on the Bluetooth function of the mobile device.

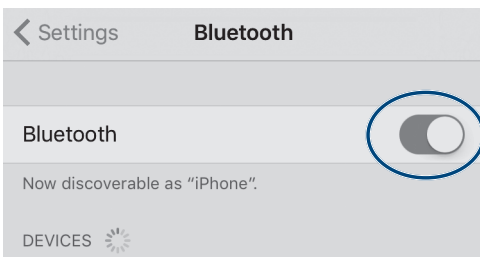

### MEMO

The explanation here uses the iPhone as an example. For details, refer to the owner’s manual of your mobile device.

\* Do not tap the “R-07” that is shown in the Bluetooth settings of the mobile device.

## Starting the R-07 Remote

1. Place the mobile device that you want to connect nearby this unit.

### MEMO

If you have more than one unit of this model, power-on only the unit that you want to pair (power-off the other units).

2. Start the R-07 Remote.

If you are starting the R-07 Remote for the first time, or if you have initialized the R-07’s settings, tap the R-07 that appears.

When the connection is completed, the Bluetooth indicator is lit.

### If you have multiple R-07 units

Specify the Bluetooth ID separately.

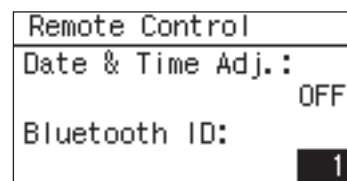

(Default in bold)

Bluetooth ID **0**-99

If you change the Bluetooth ID, you need to restart the R-07. The setting is applied when the unit is restarted.

Install R-07 Remote on each of your mobile devices, and start R-07 Remote.

Example:



Bluetooth ID: 0



Start the R-07 Remote  
Tap **Roland R-07 MIDI**

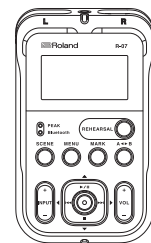

Bluetooth ID: 1



Start the R-07 Remote  
Tap **Roland R-07 MIDI-01**

### Synchronizing the time with the mobile device

When the "R-07 Remote" app is connected to the R-07, you can automatically synchronize the R-07's time with the mobile device's time.

Remote Control	
Remote:	ON
Date & Time Adj.:	<input checked="" type="checkbox"/> ON

Date & Time Adj.	<b>OFF</b>	Don't synchronize the time
	ON	Automatically synchronize the time

# Using the Metronome

## Using the Metronome by Itself

You can listen to the metronome via the preview monitor or through headphones while you practice your instrument.

1. Press [MENU] to access the “Menu” screen, use [▶/II]/[■] to select “Metronome,” and then press [●].
2. Use [▶/II]/[■] to adjust the BPM (tempo), and use [◀◀]/[▶▶] to specify the BEAT (the number of beats in each measure).

Metronome	
BPM	BEAT
<b>120</b> ↕	◀ <b>4</b> ▶

(Default in bold)

BEAT	0- <b>4</b> -8
BPM	30- <b>120</b> -250

3. Press [●] to sound the metronome.

Press it again to stop.

If headphones are connected, no sound will be output from the built-in speaker.

4. Use VOL [+] [-] to adjust the metronome’s volume.

## Sounding the Metronome During Recording

You can listen to the metronome through headphones when in recording-standby mode and during recording.

The metronome will not be sounded from the built-in speaker during recording.

1. Press [MENU] to access the “Menu” screen, use [▶/II]/[■] to select “Recorder,” and then press [●].
2. Use [▶/II]/[■] to move the cursor to Metronome Lev setting, and use [◀◀]/[▶▶] to change the setting.

Recorder
Manual Split: REC
Metronome Lev: <b>5</b>

(Default in bold)

Metronome Lev	<b>OFF</b> , 1-10
---------------	-------------------

Specify “OFF” if you don’t want to use the metronome.

# Using the Tuner

Two types of tuners, each having a different type of display, are provided: a tuner that's convenient for tuning an instrument, and a graphic tuner that's useful for vocal or brass instrument practice.

Both tuners let you choose either Auto, which automatically displays the note name, or Manual, which lets you specify the note name beforehand.

The reference pitch can be adjusted in the range of A = 435–445 Hz. You can use either the built-in mic or the MIC/AUX IN input.

## Basic Operation for the Tuner or Graphic Tuner

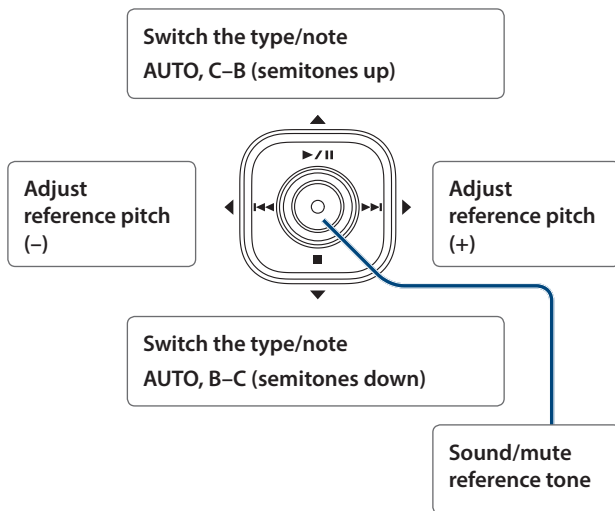

Use **[▶/II/■]** to specify the desired note name, or AUTO. With the factory settings, this is set to AUTO.

Use **[◀◀/▶▶]** to specify the reference pitch that you want to use for tuning. With the factory settings, this is set to A = 440 Hz.

If you press **[●]**, a reference tone of the pitch you specified will be sounded from the built-in speaker or in your headphones.

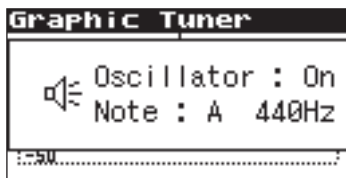
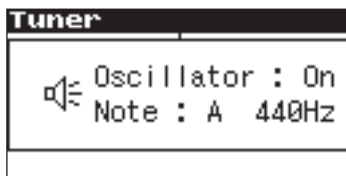

If you've selected AUTO, the "A" note will sound. Press the **[●]** once again to mute the reference tone.

## Tuner

This tuner provides a convenient way to tune your instrument.

1. Press **[MENU]** to access the "Menu" screen, use **[▶/II/■]** to select "Tuner," and then press **[●]**.
2. Use **[▶/II/■]** to specify the type/note of the tuner, and use **[◀◀/▶▶]** to specify the reference pitch.

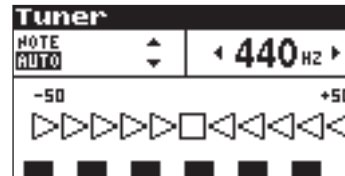

(Default in bold)

Type/Note	<b>AUTO</b> /C, C#, D, D#, E, F, F#, G, G#, A, A#, B
Reference pitch	435 Hz– <b>440 Hz</b> –445 Hz

3. Facing the microphone, play the note that you want to tune.

Tune your instrument so that the center indicator is illuminated in the lower part of the display.

When the pitch is correct, the dashed line at the bottom will stop moving.

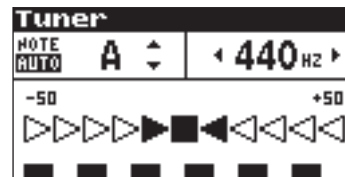

If the pitch is below the specified note, the left side will light and the dashed line will flow from right to left.

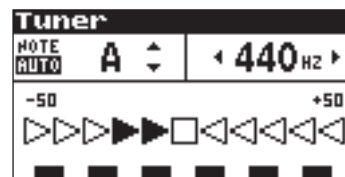

If the pitch is above the specified note, the right side will light and the dashed line will flow from left to right.

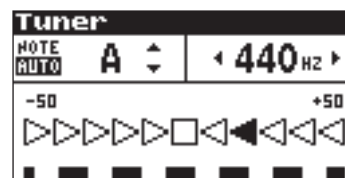

### MEMO

When using the tuner or graphic tuner, the input level is fixed for the internal microphone and MIC/AUX IN input, and cannot be adjusted.

## Graphic Tuner

This tuner graphically shows the pitch change in real time.

It is a convenient way for you to practice singing or playing a wind instrument with a stable pitch.

1. Press [MENU] to access the "Menu" screen, use [▶/II]/[■] to select "Graphic Tuner," and then press [●].
2. Use [▶/II]/[■] to specify the type/note of the tuner, and use [◀◀]/[▶▶] to specify the reference pitch.

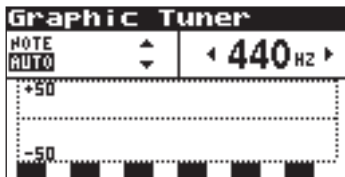

(Default in bold)

Type/Note	<b>AUTO</b> /C, C#, D, D#, E, F, F#, G, G#, A, A#, B
Reference pitch	435 Hz- <b>440 Hz</b> -445 Hz

3. Facing the microphone, play the note that you want to tune.

Adjust the pitch so that the graph value comes to the center ( $\pm 0$ ) of the vertical axis. When the pitch is correct, the dashed line at the bottom will stop moving.

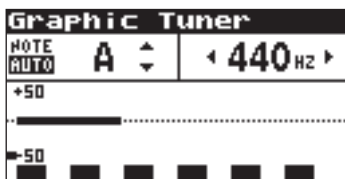

If the pitch is below the specified note, a position below the center line will light, and the dashed line will flow from right to left.

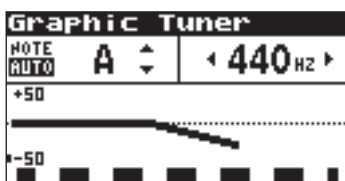

If the pitch is above the specified note, a position above the center line will light, and the dashed line will flow from left to right.

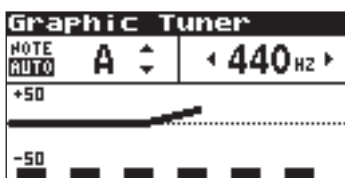

### MEMO

When using the tuner or graphic tuner, the input level is fixed for the internal microphone and MIC/AUX IN input, and cannot be adjusted.

# Connecting to Your Computer

By using a USB cable to connect the R-07 to your computer, you can transfer files from the R-07's microSD card into your computer and use them in your music software. You can also transfer files from your computer to the R-07 and play them back on the R-07. For details, refer to "Types of Files that Can be Played" (p. 25).

## Transferring Files with a Computer (Mass Storage)

### Connecting the R-07 to Your Computer

1. Start up your computer.
2. Make sure that a microSD card is inserted in the R-07's microSD card slot.  
For details, refer to "Inserting a microSD Card" (p. 8).
3. Switch on the R-07's power (p. 6).
4. Access the main screen.
5. Use the commercially available USB cable to connect the R-07 to your computer.

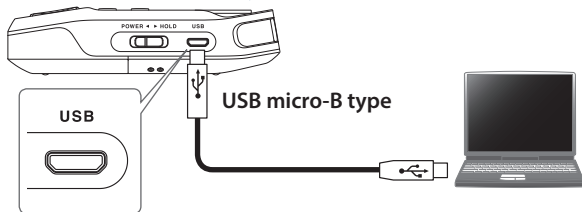

#### NOTE

- When connecting the USB cable to your computer, grasp the base of the connector, and avoid touching the metallic portion of the plug.
- If you connect the R-07 to your computer with no microSD card inserted, the R-07's display will indicate "No Card."
- The R-07 will not be recognized if you connect it to your computer when the "Menu" screen is shown, or during playback or recording. Disconnect the USB cable that's between the R-07 and your computer, and perform the procedure again from step 3.
- The R-07's various functions are unavailable in the "Now connecting" screen when connected to a computer. Operations of the buttons or switches will be ignored.
- If your computer displays the message "Insert a disk with this type of file ...," click [Cancel].

6. Use **[▶/II]/[■]** to select "Storage," and press **[●]**.

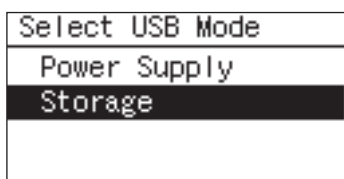

After a while, the computer will detect the R-07, and the R-07's

display will show the "Now connecting" screen.

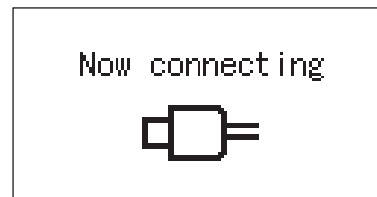

Your computer will recognize the R-07's microSD card in the following way.

Windows	Appears in Computer or Explorer under a name such as removable disk.
OS X/macOS	Appears on the desktop with a name such as NO NAME.

To copy files, use your computer to drag and drop them.

### Disconnecting from Your Computer

Here's how to disconnect the R-07 from your computer. You must use the following procedure to end the connection before you disconnect the USB cable.

#### NOTE

Do not switch off the R-07's power, disconnect the USB cable, or remove the microSD card while the R-07 is connected to your computer.

#### Windows 7/8/10

1. In the Windows task tray, click icon, and then icon.
2. Click on the message "Eject WAV/MP3 recorder R-07" appears above the task tray.
3. When you see the message "Safe to Remove the Hardware," you can disconnect the USB cable that's between the R-07 and your computer.

#### OS X/macOS

1. Drag "NO NAME" into the trash in the dock.



\* This screen shot was taken from macOS Sierra.

\* The display might be different depending on your system.

When you drag to the location of the trash at the right edge of the dock, the trash can will change to , allowing you to stop the connection.

2. Stop the connection.

When the "NO NAME" or "Unnamed" icon disappears from the desktop, you can disconnect the USB cable that's between the R-07 and your computer. Alternatively, you can switch off the R-07's power.

# Handling Files and Folders

The R-07 stores audio files on the microSD card.

The “Finder” screen provides various functions for listing, deleting, or copying these files. You can also create folders and move files between folders to manage your data.

## File structure on the R-07's microSD card

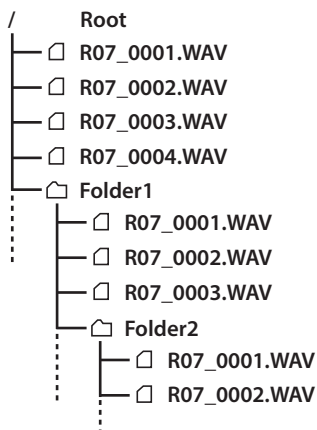

/	<b>Root</b>	Top level of the R-07
□	<b>File</b>	Use [▶/II]/[■] to change the selected file
□	<b>Folder</b>	Press [▶▶I] to enter a folder Press [I◀◀] to leave a folder

### MEMO

- You can rename a file or folder (p. 34).
- You can create a folder in a desired location (p. 37).

## Basic Operation

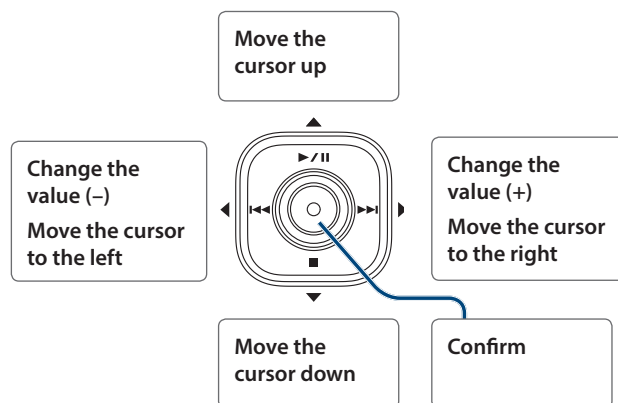

1. Press [MENU] to access the “Menu” screen, use [▶/II]/[■] to select “Finder,” and then press [●].
2. Use [▶/II]/[■] to select a file or folder, and then press [●].

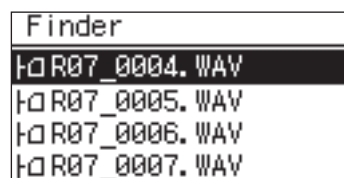

### MEMO

To make a selection from inside a folder (a lower folder), select that folder and press [▶▶I]. To select a higher folder, press [I◀◀].

3. Use [▶/II]/[■] to select a function, and press [●].

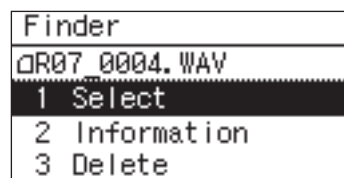

### NOTE

Do not turn off the power or remove the microSD card while the following screen is shown.

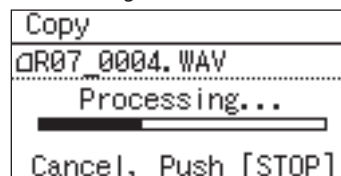

### Operations in the "Finder" screen

Selection	Function	Result	Procedure
File	Select	Selects the file and moves to the main screen.	p. 33
	Information	Shows information about the file. Alternatively, protects the file name.	p. 33
	Delete	Deletes the file.	p. 34
	Rename	Renames the file.	p. 34
	Move	Moves the file.	p. 34
	Copy	Copies the file.	p. 34
	Divide	Splits the file.	p. 35
	Combine	Joins the file.	p. 35
	Trim	Deletes the beginning and end of the file.	p. 36
	MP3 Convert	Converts a WAV file into MP3.	p. 36
Folder	Repair	Repairs the file. * This menu item is shown only if the R-07 has detected a damaged file.	p. 37
	Select	Selects the folder and moves to the main screen.	p. 33
	Information	Shows information about the folder.	p. 33
	Delete	Deletes the folder.	p. 34
	Rename	Renames the folder.	p. 34
	Make Folder	Creates a new folder.	p. 37

## Opening a File or Folder

Here's how to select and play a file from the list of recorded files. When you select a folder, the current location will change to the selected folder, and you can use the main screen to choose files from within the selected folder. You can also record into the selected folder.

1. In the "Finder" screen, select a file or folder.
2. Choose "Select."

You will return to the main screen with that file or folder selected.

## Viewing Information

1. In the "Finder" screen, select a file or folder.
2. Select "Information."

The information will be displayed.

File Info	
R07_0002.WAV	
Date	17/09/03 12:25
Size	32.95MB
Write Protect	ON

Displayed information	File or folder name
	Date (date of creation)
	Size
	Write protect setting (on/off)
	Type (Rec Mode)
	Sampling Rate

### Protect a file

You can protect a file so that it cannot be erased or renamed accidentally.

Use [◀◀]/[▶▶] to turn the Protect setting on/off.

When you turn the Write Protect setting "ON," the icon shown in the finder changes shape.

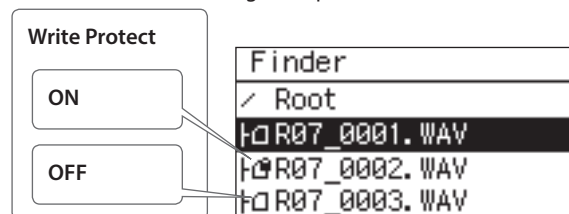

3. Press [MENU] three times to return to the main screen.

## Deleting a File or Folder

1. In the “Finder” screen, select a file or folder.
2. Choose “Delete.”
3. When the confirmation screen appears, press [●] to confirm the operation.

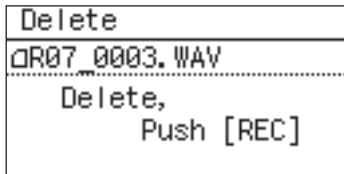

### MEMO

If you decide to cancel, press [MENU] before you press [●].

4. Press [MENU] twice to return to the main screen.

## Renaming a File or Folder

1. In the “Finder” screen, select a file or folder.
2. Choose “Rename.”
3. Use [◀▶]/[▶▶]/[◀◀] to move the cursor to the position of the character that you want to change.

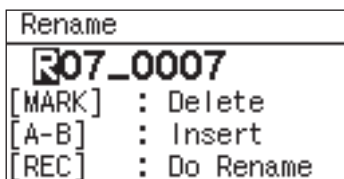

4. Use [▶/II]/[■] to change the character, and press [●] to confirm your choice.

### MEMO

- On the R-07, you can only rename file names that consist of ASCII characters (single-byte alphanumeric characters). You cannot rename a file name that contains double-byte characters such as Japanese.
- Press [A◀▶B] to insert a space, and press [MARK] to delete a character.
- If you decide to cancel, press [MENU] before pressing [●].
- If an identical name already exists, the display will indicate “Already Exists.” Please specify a different name.

5. Press [MENU] twice to return to the main screen.

## Moving a File

1. In the “Finder” screen, select a file.
2. Choose “Move.”
3. Use [▶/II]/[■] to select the move destination, and then press [●].

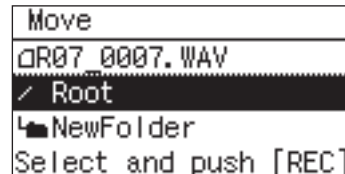

### MEMO

- If you select “Root,” the file will be moved to the top level (the root folder) of the R-07’s card. If you select a folder, the file will be moved into that folder. For details, refer to “File structure on the R-07’s microSD card” (p. 32).
- If you want to select a folder that’s inside a folder (i.e., a lower-level folder), select that folder and then press [▶▶]. To select a higher-level folder, press [◀◀].
- If you decide to cancel, press [MENU] before pressing [●].

### NOTE

You can’t perform the Move operation if there’s insufficient free space on the microSD card.

4. Press [MENU] twice to return to the main screen.

## Copying a File

1. In the “Finder” screen, select a file.
2. Choose “Copy.”
3. Use [▶/II]/[■] to select the copy destination, and press [●].

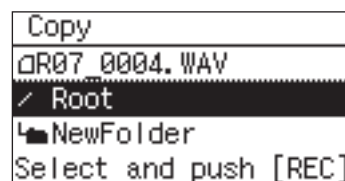

### MEMO

- If you select “Root,” the file will be copied to the top level (the root folder) of the R-07’s card. If you select a folder, the file will be copied to that folder. For details, refer to “File structure on the R-07’s microSD card” (p. 32).
- If you want to select a folder that’s inside a folder (i.e., a lower-level folder), select that folder and then press [▶▶]. To select a higher-level folder, press [◀◀].
- If you decide to cancel, press [MENU] before pressing [●].

4. Press [MENU] twice to return to the main screen.

### NOTE

If you copy a file within the same folder, “-1” will be appended to the name of the copied file.

## Dividing a File

1. In the “Finder” screen, select a file.
2. Choose “Divide.”
3. Use **[▶/II/■]** and **[◀◀/▶▶]** to play, fast-forward, and rewind through the file to find the point at which you want to divide it. When you’ve specified the point at which to divide the file, press **[●]**.

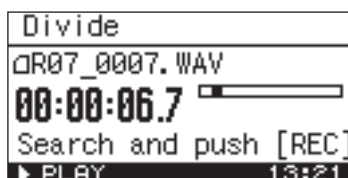

4. When the confirmation message appears, press **[●]** to confirm the operation.

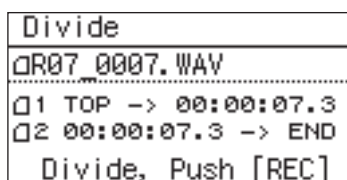

### MEMO

If the Save Original File setting (p. 40) is turned on, each divided file will be saved as a new file. In this case, the new files will have “-1” and “-2” automatically appended to their name. The original file will remain unchanged. If the original file is named R07\_001.WAV, new files named R07\_001-1.WAV and R07\_001-2.WAV will be created.

### NOTE

If the microSD card contains insufficient free space, the message “SD Card Full” will appear, and the Divide operation cannot be executed.

5. Press **[MENU]** twice to return to the main screen.

## Combining Files

1. In the “Finder” screen, select a file.
2. Choose “Combine.”
3. Select the file that will be combined with the currently selected file.

Use **[▶/II/■]** to select the file that you want to join to the end of the file selected in step 1, and then press **[●]**.

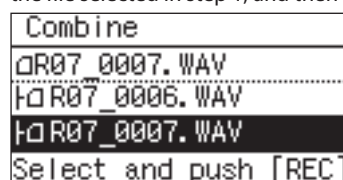

### MEMO

- If the Save Original File setting (p. 40) is turned on, the combined file will be saved as a new file. In this case, the new file will have “-1” automatically appended to its name. The original file will remain unchanged. If the original file is named R07\_0001.WAV, the combined file will be created with the name R07\_0001-1.WAV.
- You can’t combine files that have a different Sample Rate or Rec Mode.

### NOTE

- If the microSD card does not have enough free space, the message “SD Card Full” will appear, and the Combine operation cannot be executed.
- You can’t combine files if the result would exceed a file size of 2 GB.

4. Press **[MENU]** twice to return to the main screen.

## Deleting Unwanted Portions of a File (Trim)

1. In the "Finder" screen, select a file.
2. Choose "Trim."
3. Use [▶/II/■] and [◀◀/▶▶] to find the Start Point of the region that you want to keep. When you've found the desired Start Point, press [●].



4. Use [▶/II/■] and [◀◀/▶▶] to find the End Point of the region that you want to keep. When you've found the desired End Point, press [●].

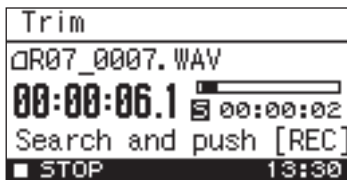

5. When the confirmation message appears, press [●] to confirm the operation.

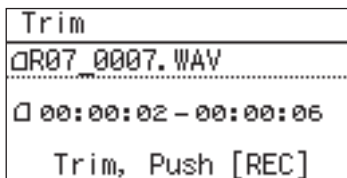

### MEMO

If the Save Original File setting (p. 40) is turned on, the trimmed file will be saved as a new file. In this case, the new file will have "-1" automatically appended to its name. The original file will remain unchanged. If the original file is named R07\_001.WAV, the trimmed file will be created with the name R07\_001-1.WAV.

6. Press [MENU] twice to return to the main screen.

## Creating an MP3 File

Not available for 88.2 kHz or 96.0 kHz sample rates

1. In the "Finder" screen, select the WAV file that you want to convert to MP3.
2. Choose "MP3 Convert."
3. Use [◀◀/▶▶] to select the desired MP3 Convert Mode setting, and press [●].

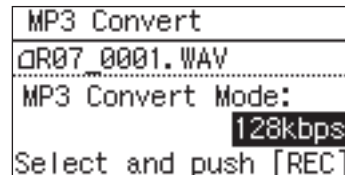

(Default in bold)

MP3 Convert Mode	64 kbps
	96 kbps
	<b>128 kbps</b>
	160 kbps
	192 kbps
	224 kbps
	320 kbps

### MEMO

Creating an MP3 file will not delete the original WAV file.

4. Press [MENU] twice to return to the main screen.

## Repairing a File

If, during recording, the power is interrupted by disconnecting the USB cable, or the microSD card is removed, the file will be damaged and unplayable. In some cases you may be able to use the Repair function to make the file playable.

**1. In the “Finder” screen, select a file.**

**2. Choose “Repair.”**

This menu item is shown only if the R-07 detects a damaged file.

**3. When the confirmation message appears, press [●].**

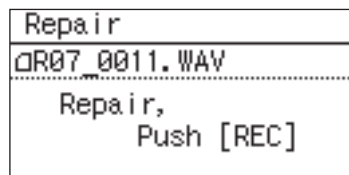

If you decide to cancel, press [MENU] before you press [●].

**4. Press [MENU] twice to return to the main screen.**

## Creating a Folder

**1. In the “Finder” screen, select the location at which you want to create a folder.**

**To create a folder at the Root level**

Use [▶/II]/[■] to select Root, and press [●].

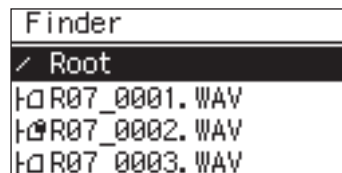

**To create a folder within a folder**

Use [▶/II]/[■] to select the folder in which the new folder is to be created.

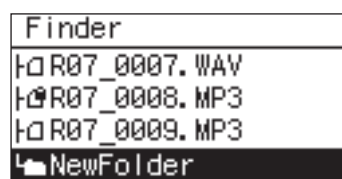

Press [▶▶] to enter the folder.

Use [▶/II]/[■] to select the folder name shown at the top, and press [●].

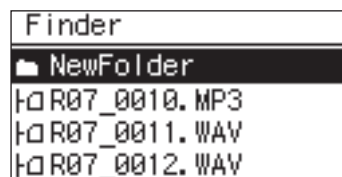

**2. Use [▶/II]/[■] to choose “Make Folder,” and press [●].**

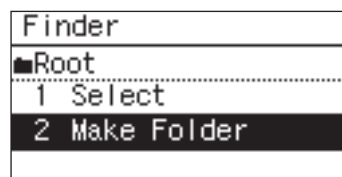

The confirmation screen appears.

**3. Press [●] to confirm the operation.**

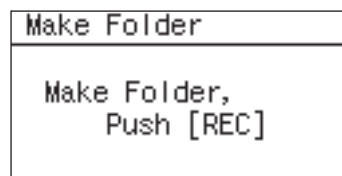

A “New Folder” will be created.

If you decide to cancel, press [MENU] before you press [●].

**4. Press [MENU] twice to return to the main screen.**

# Settings for the R-07

In the “Menu” screen you can make various settings for the R-07 itself, such as settings for recording and playback, and the date and time.

## Basic Procedure

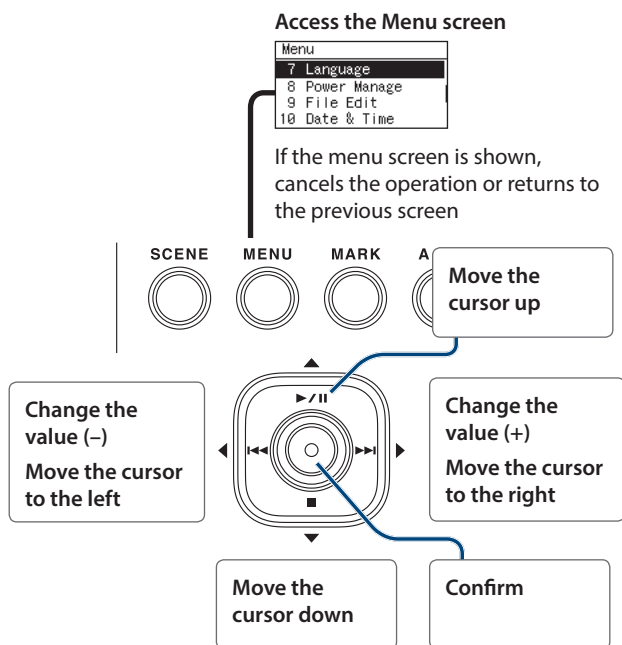

1. Press [MENU] to access the “Menu” screen, use [▶/II]/[■] to choose the desired settings category, and then press [●].

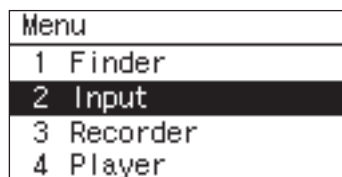

### NOTE

You can't move to a different screen while a file is playing or recording. You must stop playback or recording before moving to a different screen.

2. Use [▶/II]/[■] to move the cursor to the menu setting that you want to change, and use [◀◀]/[▶▶] to change the value.

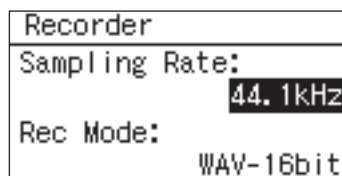

## List of settings

### Category: Finder

Here you can copy or delete audio files that are on a microSD card inserted in the microSD card slot (p. 32).

### Category: Input

Menu item	Effect	Value (default value: bold)
Limiter	Specifies whether to use the limiter or auto gain control (p. 16).	OFF, <b>ON</b> , AGC
Low Cut Freq.	Cuts the low-frequency region (p. 16).	<b>OFF</b> , 100 Hz, 200 Hz, 400 Hz
Rehearsal Time	Specifies the length of time that will be used to automatically set the recording level (p. 18).	Manual, 30 sec, <b>1 min</b> , 3 min, 5 min
Rec Monitor Sw	Specifies whether the audio input will be monitored via headphones during recording.	OFF, <b>ON</b>
EXT Mic Type	Specifies the type of mic that is connected to the MIC/AUX IN jack (p. 19).	Mono, <b>Stereo</b>
Plug In Power	Turn this ON if you've connected a plug-in powered mic (a small condenser mic that requires power to be supplied, such as used with a computer). A voltage of 2.5 V will be supplied (p. 20).	<b>OFF</b> , ON

## Category: Recorder

Menu item	Effect	Value (default value: bold)
Sampling Rate	Specifies the sampling rate for recording (p. 14). * If this setting is 88.2 kHz or 96.0 kHz, the only choices for REC Mode are WAV-16 bit and WAV-24 bit.	44.1 kHz, 48.0 kHz, 88.2 kHz, <b>96.0 kHz</b>
Rec Mode	Specifies the type of file for recording (p. 14). * 2xWAV-16 bit, 2xWAV-24 bit, MP3 and WAV+MP3 can be selected only if the Sample Rate is 44.1 kHz or 48.0 kHz.	2xWAV-16 bit, 2xWAV-24 bit, WAV+MP3, MP3-64 kbps, MP3-96 kbps, MP3-128 kbps, MP3-160 kbps, MP3-192 kbps, MP3-224 kbps, MP3-320 kbps, WAV-16 bit, <b>WAV-24 bit</b>
Pre-Rec	Specifies whether recording starts two seconds before you press [●] (p. 18).	<b>OFF</b> , ON
File Name	Specifies how the file name is to be assigned.	Date, <b>Name</b>
Auto Rec Start	Specifies the Auto Rec Start setting (p. 18).	<b>OFF</b> , 2 sec, 5 sec, 10 sec, Level 1, Level 2, Level 3
Split Type	Specifies the Split Type (p. 21).	64 MB, 128 MB, 256 MB, 512 MB, 1 GB, <b>2 GB</b> , Level 1, Level 2, Level 3
Manual Split	Specifies the button that splits the file during recording (p. 21)	OFF, AB, <b>REC</b>
Metronome Lev	Sets the volume of the metronome sounded during recording.	<b>OFF</b> , 1–10

## Category: Player

Menu item	Effect	Value (default value: bold)
Play Mode	Specifies the order in which files will play (p. 22).	SINGLE, SEQUENTIAL, SHUFFLE
Repeat	Specifies whether Repeat will be enabled (p. 22).	<b>OFF</b> , ON
Speed	Specifies the playback speed (p. 24).	50%, 60%, 70%, 80%, 90%, <b>100%</b> , 110%, 120%, 130%, 140%, 150%
Rev Type	Specifies the type of reverb (p. 24).	<b>OFF</b> , HALL1, HALL2, ROOM, PLATE
Rev Depth	Specifies the depth of reverb (p. 25).	1– <b>10</b>
Speaker	Specifies whether sound is output from the built-in speaker.	OFF, <b>ON</b>

## Category: Bluetooth

Menu item	Effect	Value (default value: bold)
Information	Shows information about connected Bluetooth headphones or speakers.	–
Pairing Audio	Pairs Bluetooth headphones or speakers with the R-07 (p. 10).	–
Connect Audio	Connects paired Bluetooth headphones or speakers with the R-07 (p. 10).	–
Disconnect Audio	Disconnects connected Bluetooth headphones or speakers.	–
Remote Control	Makes preparations for using the “R-07 Remote” app to control the R-07 (p. 26).	–

## Category: Display

Menu item	Effect	Value (default value: bold)
Contrast	Adjusts the contrast of the characters in the display.	1– <b>5</b> –10
Backlight	Adjusts the brightness of the display backlight.	OFF, 1, <b>2</b>
Display Timer	Specifies the time after which the display backlight will be darkened if no operation has been performed. (Units: seconds)	OFF, 2 sec, <b>5 sec</b> , 10 sec, 20 sec
Indicator	Specifies whether the PEAK indicator and Bluetooth indicator will also go dark in conjunction with the Display Timer.	<b>Normal</b> , Power Save
Rotate Display	Specifies whether the display is flipped vertically.	<b>OFF</b> , ON

## Category: Language

Menu item	Effect	Value (default value: bold)
–	Selects the language shown in the display.	<b>English</b> , 日本語 (Japanese)

## Settings for the R-07

---

### Category: Power Manage

Menu item	Effect	Value (default value: bold)
Auto Off	Specifies the time after which the power will turn off if no operation has been performed.	OFF, 3 min, 5 min, 10 min, 15 min, <b>30 min</b> , 45 min, 60 min
Battery	Specifies the type of battery that is installed.	<b>ALKALINE</b> , Ni-MH

### Category: File Edit

Menu item	Effect	Value (default value: bold)
Save Original File	Switches whether the original unedited file will be retained when executing a file editing operation (Divide, Combine, or Trim).	OFF, <b>ON</b>

### Category: Date & Time

Specifies the date and time (p. 7).

### Category: SD Card

Menu item	Effect	Value (default value: bold)
Information	Displays information about the microSD card.	–
Format	Formats the microSD card (p. 9)	–

### Category: Metronome

Sets the tempo or beat of the metronome (p. 28)

### Category: Tuner

Use this to tune an instrument (p. 29).

### Category: Graphic Tuner

Use this to check pitch changes during vocal or brass instrument practice (p. 30).

### Category: Factory Reset

Resets the R-07 to the factory-set condition.

The state of connection with a Bluetooth device or mobile device is also reset. You'll need to make the connection again.

### Category: Information

Shows wireless certification information for the R-07.

# Error Messages

This section explains the main error messages that may appear in the display.

Message	Problem
 <b>Clock Initialized</b>	Power for the internal clock was lost, so the internal clock has been initialized. Please specify the date and time.
 <b>Battery Low</b>	The internal batteries have run low. Replace the batteries. Alternatively, supply power via the USB port.
 <b>Improper Song</b>	This file is of a format that the R-07 cannot use.
 <b>Already Exists</b>	An identically named file or folder exists. Please use a different name to create the file or folder.
 <b>Song Protected</b>	The file is protected. Turn Write Protect "OFF" before you execute the operation.
 <b>Name Too Long</b>	The name is too long.
 <b>File System Err</b>	There is a problem with the microSD card. Format the microSD card on the R-07.
 <b>SD Unformatted</b>	The microSD card has not been formatted. Format the microSD card on the R-07.
 <b>SD Card Full</b>	The microSD card has insufficient free space. Copy files to your computer, and free up space on the microSD card.
 <b>Cannot Change</b>	The file cannot be renamed because the file name contains double-byte characters.
 <b>Over 2GB</b>	The file contains too much data.
 <b>SD Card Slow</b>	Writing to the microSD card could not be performed fast enough. Please use a microSD card that is known to work with the R-07. In some cases, repeated writing and deleting of files may cause the files to become fragmented on the microSD card, impairing the processing capability. If so, please reformat the microSD card.
 <b>SD Card Error</b>	A problem occurred while accessing the microSD card. The microSD card might be damaged.
 <b>No Card</b>	No microSD card is inserted. Insert an microSD card into the R-07.
 <b>SD Unsupported</b>	The R-07 cannot use this microSD card.
 <b>HOLD is ON</b>	Operation is not possible because the [POWER] switch is set to the HOLD position. Turn the HOLD off if you want to perform an operation.
 <b>Now Recording</b>	Currently recording. Stop recording if you want to perform an operation.
 <b>Now Playing</b>	Currently playing. Stop playback if you want to perform an operation.
 <b>AGC is ON</b>	Since Limiter is "AGC," you cannot operate the input level buttons or the rehearsal function. To operate these things, set the limiter to a setting other than "AGC."

# Troubleshooting

If you experience problems, refer to the information provided here.

If this information does not help you solve the problem, please contact a customer service location listed on the leaflet "Read Me First."

## Problems with Recording

Problem	Cause	Page
Sound recorded from the mic is heard only from the L (left) channel	If you're using a mono mic, only the L (left) channel will be recorded. If you use an external mic, check whether the mic is stereo or mono. In order to record onto both channels using a mono mic, use the "Menu" screen to set the external mic type to "MONO."	p. 19
Can't start recording	Recording will not be possible if the microSD card has less than 16 kilobytes of free space. Nor can you enter recording-standby mode.	p. 40
Recording begins at a different point than when you started	If Pre-Rec is on, the sound will be recorded starting two seconds before you press the [●].	p. 18
Can't use the mic	The internal mics cannot be used if a mic, cable, or device is connected to the MIC/AUX IN jack. If you want to use the internal mics, do not connect anything to the MIC/AUX IN jack.	p. 19
	If you're using a plug-in powered mic, you'll need to turn Plug In Power on.	p. 20
	The R-07 does not support phantom-powered mics.	–
Recorded sound is distorted	The sound will be distorted if the input level is too high. Adjust the recording level appropriately.	p. 17
Can't play back the recorded file	If, during recording, the power is interrupted by disconnecting the USB cable, or the microSD card is removed, the file will be damaged and unplayable. In some cases you may be able to use the file Repair function to recover it.	p. 37
Can't record	Recording is not possible if the microSD card is not inserted correctly. Turn off the power, and re-insert the microSD card.	p. 8
	If the microSD card has not been formatted, it will not be recognized, and the display will indicate "SD Unformatted." Please format the microSD card.	p. 9
	The microSD card will not work properly unless it was formatted on the R-07. If the card was formatted using a computer, it might have the wrong format. In this case, it might stop immediately after recording is started, or recording might not occur correctly.	p. 9
	Recording will not occur correctly if the recording level specified by INPUT [+][–] is too low. Set the recording level appropriately.	p. 17
Recording with a mono mic creates a stereo file	The R-07 records in stereo. If you connect a mono mic, a stereo file with the same sound on left and right (L, R) tracks will be created even if EXT Mic Type is set to "MONO."	p. 19
Volume of the device connected to the MIC/AUX IN jack is too low	Could you be using a connection cable that contains a built-in resistor? Please use a connection cable that does not contain a resistor.	p. 20
File was divided unexpectedly	The R-07 will automatically divide the file if the file currently being recorded exceeds a specified size, or if the recording level falls below a specified level. Set the Split Type setting to specify the file size or recording level at which the file is to be automatically divided.	p. 21

## Problems with Playback

Problem	Cause	Page
No sound	You might not hear the sound if the output volume is too low. Try gradually pushing the VOL [+].	p. 22
	Make sure that your headphones or speakers are correctly connected.	p. 10
Can't play back	Make sure that the file name is assigned correctly. The R-07 cannot use files that have a name that begins with a "." (period).	p. 22
	The R-07 can only play files with a file name extension of .MP3 or WAV.	p. 25
	A damaged file cannot be played. You might be able to recover the file by using the Repair function.	p. 37
Unintended files are played	The file Play Mode might be set to "SHUFFLE." If so, the R-07 will randomly select and play the next file. Change the setting back to "SEQUENTIAL."	p. 22

## Problems with Bluetooth Functionality

Problem	Cause	Page
Can't connect with Bluetooth headphones or speakers	Check whether the Bluetooth device is able to connect.	
	If the Bluetooth device is too far away from the R-07, it might be unable to connect. Place the Bluetooth device near the R-07.	
	Check the R-07's "Pairing Audio" to see whether pairing data might be lost. If the data is lost, perform the pairing operation once again.	
No sound from the Bluetooth headphones or speakers	No sound is output if the R-07's volume is set to "0." Raise the R-07's volume.	
	No sound is heard if you've lowered the volume of the Bluetooth headphones or speakers. Raise the volume of the Bluetooth headphones or speakers.	
Noise is heard from the Bluetooth headphones or speakers	Noise might be heard if there is a nearby device that uses the same frequency range (2.4 GHz) as the R-07. Move the R-07 away from other devices that use the same frequency range (2.4 GHz).	
	Noise might be heard if there is an obstruction such as a wall or person between the R-07 and the Bluetooth device.	
	Use the R-07 in an unobstructed location with a clear line of sight. The distance at which communication is possible might be shorter for some Bluetooth devices. Use the Bluetooth device as near as possible to the R-07.	
The R-07's Bluetooth indicator remains blinking	Depending on conditions, a Bluetooth device connected to the R-07 might be disconnected. Power-on the Bluetooth device and reconnect it. If it does not reconnect, use the R-07's "Disconnecting a Bluetooth device" function to end the connection, and then reconnect.	
Can't connect to the R-07 from an app	Delete the "Roland R-07 MIDI" that is registered on your mobile device; then re-register and connect.	

## Other Problems

Problem	Cause	Page
Power won't turn on	Check whether the USB AC adaptor or USB cable might have been disconnected, causing the power to turn off. If you're using batteries, make sure that they are oriented correctly, and not loose in the compartment. If the batteries have run low, install fresh batteries.	p. 6
	If the R-07 will not power-on even though there are not problems with the USB AC adaptor or USB cable, or if the batteries are OK, then the unit might have malfunctioned. Please contact a customer service location listed on the leaflet "Read Me First."	-
R-07 is not recognized when connected to computer	If no microSD card is inserted in the R-07, it won't be correctly recognized by the computer. If no icon appears on your computer's desktop, make sure that the microSD card is inserted correctly.	p. 8
"Menu" screen does not appear when you press [MENU]	During playback, recording, or recording-standby mode, pressing [MENU] will not display the "Menu" screen. Stop playback or recording before you press [MENU].	-
Display becomes dim	If you're using batteries, the display will be dimmed if no operation is performed during the specified Display Timer interval.	p. 39
Power turns off unexpectedly	Depending on the Auto Off setting, power will turn off automatically if no operation is performed for a specified length of time.	p. 40
	If you're using batteries, power will turn off when the batteries run low. Please install fresh batteries.	p. 6
Your settings return to their original value	When you initialize the settings, all settings that you made in the "Menu" screen etc. return to their original state. Please make the desired settings again.	p. 38
	Changes that you make to settings will return to their original state if the power was turned off without using the [POWER] switch, for example if the batteries ran low or if the USB AC adaptor or USB cable was disconnected.	p. 38
	Please make the desired settings again.	
R-07 not recognized when connected to your computer via USB	The R-07 will not be recognized by your computer if you connect it when the "Menu" screen is displayed, or during playback or recording. Please disconnect the USB cable, and try again.	p. 31

Problem	Cause	Page
File name display is slow when selecting a file	Even if the file name extension is .MP3 or .WAV, the display when selecting a file will be slower if the file is damaged, if the file is an invalid file or an unsupported type of MP3, or if the file is of a large size. This occurs because the R-07 needs to determine whether it is able to play the file.	p. 25
Feedback occurs when monitoring through headphones	If you're monitoring the recording through open-air type headphones, acoustic feedback might occur if the R-07's mics pick up the sound from your headphones. The R-07's built-in mics are able to detect even faint sound, so keep your headphones away from the built-in mics.	p. 19
Internal clock is reset	When a USB AC adaptor and USB cable are connected, or when batteries are installed, the internal clock is supplied with power and begins operating. If several minutes pass with the batteries removed, the internal clock will return to its default setting. When you turn on the power in this state, the message "Clock Initialized" will appear. If this message appears, please reset the date and time.	p. 7
Can't divide or join files	The microSD card must have twice as much free space as occupied by the corresponding file(s). It is not possible to join files that would exceed 2 GB in size.	p. 40

# Main Specifications

## High Resolution Audio Recorder: R-07

### Recorder Part

#### Tracks

- 2 (stereo)
- 4 (stereo x2) \* WAVx2 recording mode only

#### Signal Processing

AD/DA conversion: 24 bits, 44.1/48/88.2/96 kHz

### Data Type

**[For Recording]** \* Stereo only

WAVE:

Sampling Rate	44.1/48/88.2/96 kHz
Bit Depth	16/24 bits

MP3 (MPEG-1 Audio Layer 3):

Sampling Rate	44.1/48 kHz
Bit Rates	64/96/128/160/192/224/320 kbps

WAV+MP3:

Sampling Rate	44.1/48 kHz
Bit Depth	16 bits
Bit Rates	128 kbps

WAVE x 2:

Sampling Rate	44.1/48 kHz
Bit Depth	16/24 bits

**[For Playback]**

WAVE:

Sampling Rate	32/44.1/48/88.2/96 kHz
Bit Depth	16/24 bits

MP3 (MPEG-1 Audio Layer 3):

Sampling Rate	32/44.1/48 kHz
Bit Rates	32–320 kbps or VBR (Variable Bit Rate)

### Memory Card

- microSD Card
- SDHC format compatible

Recordable time (approximate)

Units: minutes

Rec Mode		microSD card capacity				
		2 GB	4 GB	8 GB	16 GB	32 GB
WAV	WAV (24 bit/96 kHz)	55	110	220	450	900
	WAV (24 bit/88.2 kHz)	60	120	240	490	980
	WAV (24 bit/48 kHz)	110	220	440	900	1800
	WAV (24 bit/44.1 kHz)	120	240	480	980	1950
	WAV (16 bit/96 kHz)	80	160	320	670	1350
	WAV (16 bit/88.2 kHz)	88	176	352	735	1470
	WAV (16 bit/48 kHz)	166	332	664	1350	2700
	WAV (16 bit/44.1 kHz)	180	360	720	1470	2950
MP3	MP3 (320 kbps)	797	1540	3080	6450	12950
	MP3 (128 kbps)	1993	3990	7980	16180	32350
WAV+MP3	WAV (16 bit/48 kHz)+MP3 (128 kbps/48 kHz)	152	305	610	1240	2490
	WAV (16 bit/44.1 kHz)+MP3 (128 kbps/44.1 kHz)	165	330	660	1345	2690
WAVE x2 (2xWAV)	WAV (24 bit/48 kHz)	55	110	220	450	900
	WAV (24 bit/44.1 kHz)	60	120	240	490	975
	WAV (16 bit/48 kHz)	83	166	332	675	1350
	WAV (16 bit/44.1 kHz)	90	180	360	735	1475

\* Each recording time is approximate. The times may change depending on the card specifications.

\* In case that there are plural files, the sum of recording time would be shorter than above.

### Input/Output

---

#### Audio Inputs

Internal Stereo Microphone

MIC/AUX IN jack (Stereo miniature phone type, plug-in powered mic)

\* The Internal Mic and the MIC/AUX IN can't be used at the same time; only the MIC/AUX IN jack is effective.

#### Audio Output

PHONES jacks (Stereo miniature phone type)

Internal Speaker for playback (mono)

\* The Internal Speaker and the PHONES jack can't be used at the same time; only the PHONES jack is effective.

#### Nominal Input Level (Variable)

MIC/AUX IN jack: -31 dBu (Default input level)

\* 0 dBu=0.775 Vrms

#### Input Impedance

MIC/AUX IN: 4.5 k ohms

#### Output Level

3 mW + 3 mW (In case 16 ohms load)

#### Recommended Load Impedance

16 ohms or greater

#### Frequency Response

20 Hz–40 kHz (+-3 dB)

#### USB Interface

USB port: USB Micro-B type

Support USB 2.0/1.1 mass storage device class

#### Bluetooth

R-07 Remote: Bluetooth technology: Bluetooth Ver 4.0

Audio transmission: Bluetooth technology: Bluetooth Ver 3.0

Transmitting Power: Specification Power Class 2 (Line of sight range 10 m (30 ft))

Profile Support: A2DP, AVRCP

CODEC Support: SBC, Qualcomm aptX Qualcomm aptX low latency

### Effects

---

\* Playback only. Excludes playback in 88.2 kHz or 96 kHz.

\* Reverb and Speed Change can't be used at the same time.

#### Reverb

4 types (HALL1, HALL2, ROOM, PLATE)

#### Speed Change

50–150% of playback speed

### Other

---

#### Display

Graphic LCD 128 x 64 dots (white backlit)

#### Power Supply

Alkaline battery (AA, LR6) x 2,

or Rechargeable Ni-MH battery (AA, HR6) x 2,

or Supplied from the computer via USB

#### Current Draw

350 mA (MAX)

#### Duration of continuous use with Alkaline battery operation

Playback: Approximately 15 hours

Recording: Approximately 15 hours

\* This can vary depending on the specifications of the batteries, capacity of the batteries, and the conditions of use.

#### Dimensions

61 (W) x 103 (D) x 26 (H) mm

2-7/16 (W) x 4-1/16 (D) x 1-1/16 (H) inches

#### Weight

150 g/6 oz (including batteries)

#### Accessories

Leaflet "Read Me First"

Owner's manual

microSD card (inserted in the R-07)

Batteries (two AA)

#### Options

Microphone Stand Adaptor: OP-MSA1

Binaural Microphones / Earphones: CS-10EM

Stereo Microphone: CS-15S

\* This document explains the specifications of the product at the time that the document was issued. For the latest information, refer to the Roland website.