



MQ 80P

TWO-WAY INDOOR OUTDOOR SPEAKER



Description

High intelligibility, high efficiency and compact design make the RCF MQ80P 2-way horn-loaded sound projector speaker system the ideal solution to get clear voice and music reproduction in mid-size environment. Suitable for PA systems and background/foreground music systems. Thanks to its 90° X 60° constant directivity and to simple accessories it can be combined in clusters of 2 or more pieces to get wide and smooth coverage and to reduce the installation points. It is suitable for both indoor and outdoor installations (IP 55). The woofer is a high-excursion, PP coated paper cone – rubber surround design mounted in a tuned enclosure (port can be sealed for full outdoor installation).

The tweeter is a horn-loaded compression driver with phase plug, the only way to get real and crispy intelligible voice reproduction even in wide and noisy environments. Installation of the MQ80P is quick thanks to the unique bracket with several fixing points and aiming facilities. Connections are made by a multi-pole cable. Wattage taps and voltage adjustments together with 8-ohm operation are selectable by means of a Rotary switch, accessible under a sealed cover. The enclosure is constructed of high density UV resistant self-extinguishing polystyrene with robust steel grill.

Features

- › 5" woofer with 1" compression driver
- › Power selectable (100 V): 30 W – 10 W – 10 W – 5 W
- › 94 dB sensitivity
- › Colour white RAL 9016 and black RAL 9005
- › Plastic body, steel grille
- › Protection grade IP 55



MQ 80P

TWO-WAY INDOOR OUTDOOR SPEAKER

Part Number

Line Art 2D

13000094 MQ 80P B
13000096 MQ 80P W

Black - RAL 9005 EAN 8024530005771
White - RAL 9016 EAN 8024530005795



MQ 80P

TWO-WAY INDOOR OUTDOOR SPEAKER

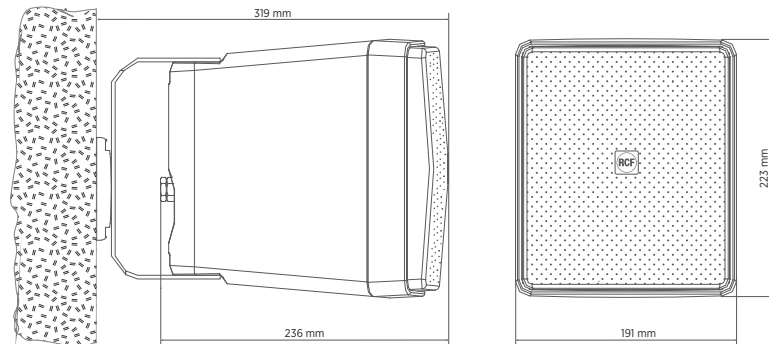

TECHNICAL SPECIFICATIONS

Acoustical specifications	Frequency Response (-10dB)	100 Hz - 20000 Hz
	Max SPL @ 1m	114 dB
	Horizontal coverage angle	90°
	Vertical coverage angle	60°
	System Sensitivity	94 dB
Power section	Amplification	Full Range
	Nominal Impedance	8 ohm
	Power Handling	60 W
	Peak Power Handling	240 W PEAK
	Crossover Frequencies	3000 Hz
	Recommended Amplifiers	UP 2321, UP 2162
Transducers	Dome Tweeter	1 x 1.0"
	Woofer	1 x 5.0"
Input/Output section	Input connectors	Cable
	Output connectors	Cable
	Constant Voltage Transformer	100 V
	Power selection 1	30 W - 333 ohm
	Power selection 2	20 W - 500 ohm
Standard compliance	Power selection 3	10 W - 1000 ohm
	Power selection 4	5 W - 2000 ohm
	IP protection grade	IP 55
	Safety agency	CE compliant



MQ 80P

TWO-WAY INDOOR OUTDOOR SPEAKER

Physical specifications	Cabinet/Case Material	Plastic
	Hardware	Wall mount bracket
	Grille	Steel
	Color	White - RAL 9016, Black - RAL 9005
Size / Weight	Height	223 mm / 8.78 inches
	Width	191 mm / 7.52 inches
	Depth	236 mm / 9.29 inches
	Weight	3.65 kg / 8.05 lbs