



HD 310T

ALUMINIUM HORN SPEAKER WITH DRIVER AND TRANSFORMER



Description The HD 310/T are compact, lightweight and watertight horn speakers. They are designed to provide high efficiency and characterized by the high intelligibility of the reproduced sound with low distortion. The built-in line transformer makes it possible to connect the horn loudspeaker to both 70 and 100 V constant voltage lines, and select the demnlievered power by means of a rotary dial on the rear cover

- Features**
- › Built-in line transformer with multitap power selector on rear cover
 - › Hi-pass filter for protecting driver against out-of-range low-freq
 - › IP 66 construction for indoor-outdoor environmental temperature between -25°C to +70°C
 - › Aluminium flare with UV-stabilized autoextinguishing UL-HB ABS rear cover

Part Number 13130001 HD 310T Grey - RAL 7035 EAN 8024530001254



HD 310T

ALUMINIUM HORN SPEAKER WITH DRIVER AND TRANSFORMER

Line Art 2D

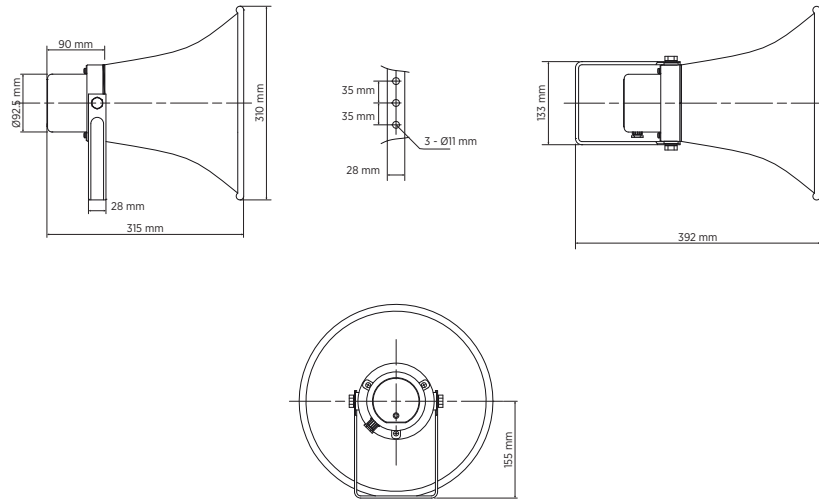

TECHNICAL SPECIFICATIONS

Acoustical specifications	Frequency Response (-10dB)	240 Hz - 10000 Hz
	Max SPL @ 1m	123 dB
	Coverage angle	80°
Power section	System Sensitivity	108 dB
	Nominal Impedance	8 ohm
	Power Handling	30 W
Transducers	Peak Power Handling	120 W PEAK
	Compression Driver	1 x 1.5"
Input/Output section	Input connectors	Cable
	Output connectors	Cable
	Constant Voltage Transformer	70/100 V
	Power selection 1	30 W - 333 ohm
	Power selection 2	20 W - 500 ohm
	Power selection 3	15 W - 667 ohm
	Power selection 4	10 W - 1000 ohm
Standard compliance	Power selection 5	5 W - 2000 ohm
	Power selection 6 (100 V)	2.5 W - 4000 ohm
	IP protection grade	IP 66
Physical specifications	Safety agency	CE compliant
	Cabinet/Case Material	Aluminum
	Hardware	Stainless steel U bracket
	Color	Grey - RAL 7035



HD 310T

ALUMINIUM HORN SPEAKER WITH DRIVER AND TRANSFORMER

Size / Weight	Depth	315 mm / 12.4 inches
	Diameter	310 mm / 12.2 inches
	Weight	1.9 kg / 4.19 lbs