

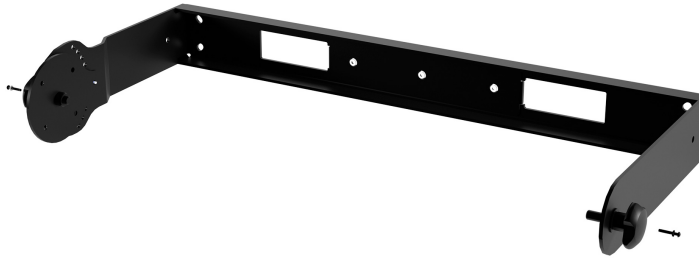

# H-BR ART 915

HORIZONTAL MOUNT BRACKET



## Description

H-BR Horizontal Mount Bracket for ART 9 Series 15" models. It features robust brackets and hardware to mount the speaker system to a wall, ceiling, or truss in horizontal configuration. Adjustable inclination allows obtaining the desired sound coverage.

## Standard compliance

Safety agency

CE compliant

## Size / Weight

Weight

5 kg / 11.02 lbs

## Physical specifications

Color

Black

Line Art 2D

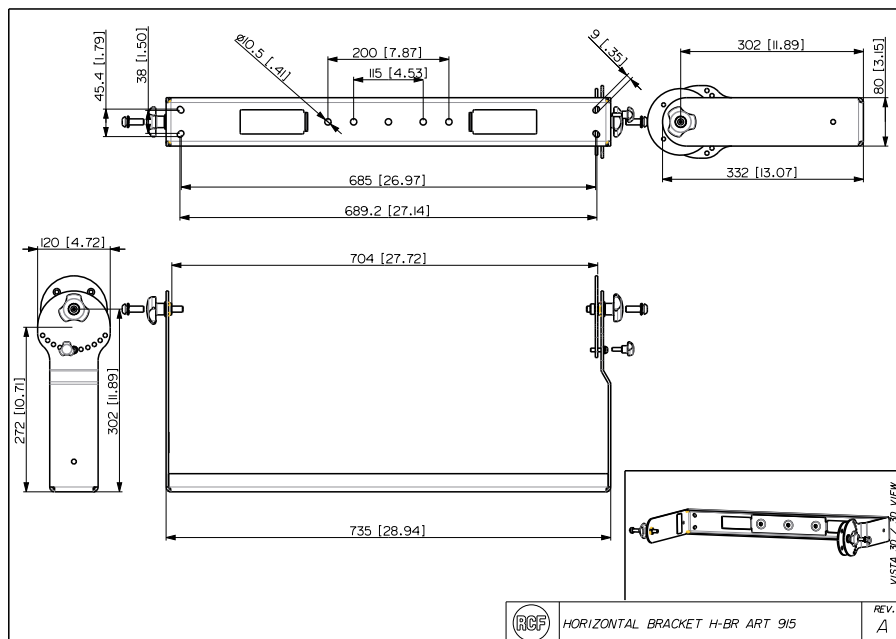

## Part Number

13360479 H-BR ART 915

Black

EAN 8024530019198

## Technical Specifications

Products are continually improved. All specifications are therefore subject to change without notice.