



# P9HW

## Wired Bodypack Personal Monitor

Shure P9HW manual. Contains how-to, charger, battery, and specification information for the Shure P9HW wired two-channel stereo bodypack system.

Version: 2.7 (2025-H)

# Table of Contents

<b>P9HW Wired Bodypack Personal Monitor</b>	<b>3</b>	<b>MixMode and Stereo Monitoring</b>	<b>8</b>
<b>IMPORTANT SAFETY INSTRUCTIONS</b>	<b>3</b>	Stereo (default)	8
SAFETY PRECAUTIONS	4	MixMode	9
CAUTION	4	<b>Shure SB900-Series Rechargeable Battery</b>	<b>10</b>
WARNING	4	Single Bay Charger	10
WARNING	4	Multiple Bay Chargers	11
<b>General Description</b>	<b>4</b>	Important Tips for Care and Storage of Shure Rechargeable Batteries	12
<b>P9HW Bodypack</b>	<b>4</b>	Battery Life	12
<b>Setup</b>	<b>6</b>	<b>Pin Assignments</b>	<b>13</b>
<b>Audio Settings</b>	<b>7</b>	<b>Optional Accessories and Replacement Parts</b>	<b>14</b>
<b>Utilities</b>	<b>8</b>	<b>Specifications</b>	<b>14</b>
		<b>Certifications</b>	<b>15</b>

---

# P9HW

## Wired Bodypack Personal Monitor

---

### IMPORTANT SAFETY INSTRUCTIONS



1. READ these instructions.
2. KEEP these instructions.
3. HEED all warnings.
4. FOLLOW all instructions.
5. DO NOT use this apparatus near water.
6. CLEAN ONLY with dry cloth.
7. DO NOT block any ventilation openings. Allow sufficient distances for adequate ventilation and install in accordance with the manufacturer's instructions.
8. DO NOT install near any heat sources such as open flames, radiators, heat registers, stoves, or other apparatus (including amplifiers) that produce heat. Do not place any open flame sources on the product.
9. DO NOT defeat the safety purpose of the polarized or grounding type plug. A polarized plug has two blades with one wider than the other. A grounding type plug has two blades and a third grounding prong. The wider blade or the third prong are provided for your safety. If the provided plug does not fit into your outlet, consult an electrician for replacement of the obsolete outlet.
10. PROTECT the power cord from being walked on or pinched, particularly at plugs, convenience receptacles, and the point where they exit from the apparatus.
11. ONLY USE attachments/accessories specified by the manufacturer.
12. USE only with a cart, stand, tripod, bracket, or table specified by the manufacturer, or sold with the apparatus. When a cart is used, use caution when moving the cart/apparatus combination to avoid injury from tip-over.



13. UNPLUG this apparatus during lightning storms or when unused for long periods of time.
14. REFER all servicing to qualified service personnel. Servicing is required when the apparatus has been damaged in any way, such as power supply cord or plug is damaged, liquid has been spilled or objects have fallen into the apparatus, the apparatus has been exposed to rain or moisture, does not operate normally, or has been dropped.
15. DO NOT expose the apparatus to dripping and splashing. DO NOT put objects filled with liquids, such as vases, on the apparatus.
16. The MAINS plug or an appliance coupler shall remain readily operable.
17. The airborne noise of the Apparatus does not exceed 70dB (A).
18. Apparatus with CLASS I construction shall be connected to a MAINS socket outlet with a protective earthing connection.
19. To reduce the risk of fire or electric shock, do not expose this apparatus to rain or moisture.
20. Do not attempt to modify this product. Doing so could result in personal injury and/or product failure.
21. Operate this product within its specified operating temperature range.

## SAFETY PRECAUTIONS

The possible results of incorrect use are marked by one of the two symbols—"WARNING" and "CAUTION"—depending on the imminence of the danger and the severity of the damage.

	WARNING: Ignoring these warnings may cause severe injury or death as a result of incorrect operation.
	CAUTION: Ignoring these cautions may cause moderate injury or property damage as a result of incorrect operation.

## CAUTION

- Never disassemble or modify the device, as failures may result.
- Do not subject to extreme force and do not pull on the cable or failures may result.
- Keep the product dry and avoid exposure to extreme temperatures and humidity.

## WARNING

- If water or other foreign objects enter the inside of the device, fire or electric shock may result.
- Do not attempt to modify this product. Doing so could result in personal injury and/or product failure.

This device is able to produce sound volume higher than 85 dB SPL. Please check your maximum allowed continuous noise exposure level based on your national employment protection requirements.

## WARNING

**LISTENING TO AUDIO AT EXCESSIVE VOLUMES CAN CAUSE PERMANENT HEARING DAMAGE. USE AS LOW A VOLUME AS POSSIBLE.** Over exposure to excessive sound levels can damage your ears resulting in permanent noise-induced hearing loss (NIHL). Please use the following guidelines established by the Occupational Safety Health Administration (OSHA) on maximum time exposure to sound pressure levels before hearing damage occurs.

<b>90 dB SPL</b> at 8 hours	<b>95 dB SPL</b> at 4 hours	<b>100 dB SPL</b> at 2 hours	<b>105 dB SPL</b> at 1 hour
<b>110 dB SPL</b> at ½ hour	<b>115 dB SPL</b> at 15 minutes	<b>120 dB SPL</b> Avoid or damage may occur	

This product is intended for professional use only. This product should only be sold through professional sales channels.

## General Description

The Shure P9HW is a wired, two-channel stereo bodypack system designed to replace loudspeakers used for onstage monitoring. The portable, lightweight P9HW has several advantages over onstage monitor loudspeakers: it is less visible, offers improved clarity and control of sound, reduces the chances of feedback, and reduces stage clutter. It is a versatile system, designed for use in sound reinforcement applications including public address, live music, studio recording, broadcast, and theater.

# P9HW Bodypack

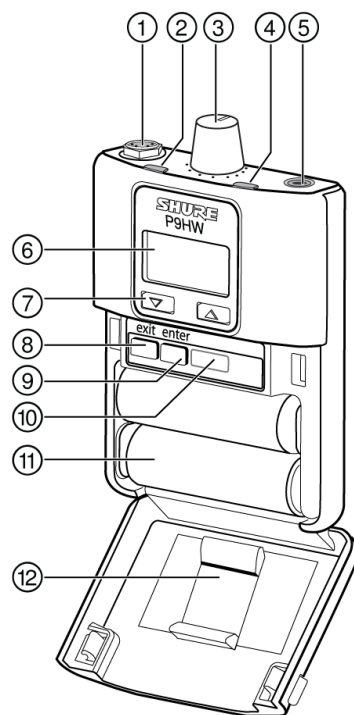

<b>① Audio Input</b>	Use the supplied Y-splitter cable to connect up to two sources. <b>Important:</b> Align the red dot on the cable with the notch inside the bodypack input.
<b>② Clip Indicator</b>	Illuminates when the input is overloaded. Turn the volume down at the mixer until the light remains off.
<b>③ Volume Knob / Power Switch</b>	Turn to power on/off and adjust headphone volume
<b>④ Battery LED</b>	Indicates battery health <b>Note:</b> see the battery life table for specific runtime values
<b>⑤ Headphone Output</b>	Use earphones or headphones with a 3.5 mm (1/8-inch) plug
<b>⑥ Display</b>	Shows settings and menu navigation
<b>⑦ Navigation buttons (▲ ▼)</b>	Use to scroll through menu and adjust settings
<b>⑧ Exit button</b>	Press to return to previous screen
<b>⑨ Enter button</b>	Press to enter a menu screen or to confirm a setting
<b>⑩ Factory Service Window</b>	Used for importing firmware onto the bodypack at the factory (not user-serviceable)

⑪ <b>Battery Compartment</b>	Uses a Shure SB900-series rechargeable battery or two AA batteries
⑫ <b>Removable AA Adapter</b>	<p>Remove to use with a Shure SB900-series rechargeable battery</p> <p><b>Note:</b> To remove, open the door and slide the adapter out. To reinstall, press the adapter into place—there is an audible click when seated.</p>

## Setup

① <b>Insert batteries</b>	Use the Shure SB900C rechargeable battery pack or two AA batteries.
② <b>Connect the bodypack to an audio source using the supplied Y-splitter cable</b>	<p>Connect the 5-pin LEMO connector to the bodypack, with the red dot on the cable aligned with the notch inside the bodypack connector. Route the two XLR connectors on the cable to the appropriate mixer outputs. See the system overview diagram for a signal routing example.</p> <p><b>Note:</b> the bodypack can connect either directly to the mixer or through a patch bay on stage.</p>
③ <b>Put on the earphones and connect them to the headphone output</b>	The P9HW is designed to perform best with Shure earphones, but works with any headphones or in-ear monitors that have a standard 1/8-inch (3.5 mm) stereo plug.
④ <b>Turn the power on</b>	<p>Turn the volume knob clockwise until it clicks to turn on the power.</p> <p><b>Caution: do not turn the volume knob all the way up when turning the power on.</b></p>
⑤ <b>Slowly increase the volume until it reaches a comfortable level for listening</b>	To set a maximum volume limit, use the VLIMIT function. See the utilities section of this guide for more information.

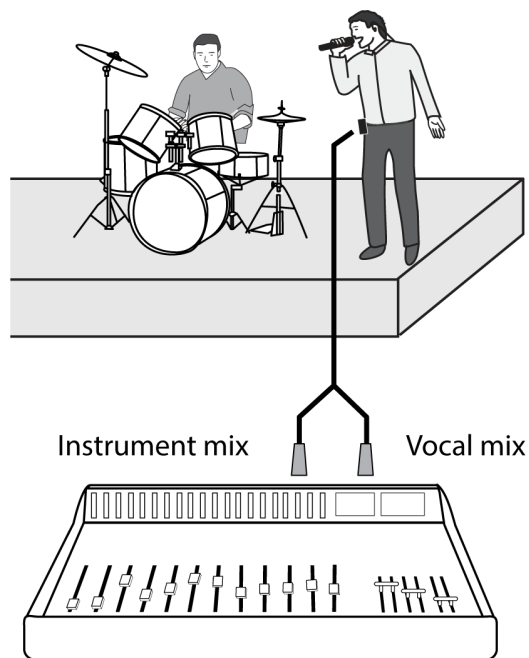

System Overview

## Audio Settings

<p><b>MODE</b></p>	<p>STEREO: Audio from channel 1 is heard on the left earphone; audio from channel 2 is on the right earphone. MIXMODE: Both channels are heard on the left and right earphones. The blend between mixes is adjustable.</p>
<p><b>EQ</b></p>	<p>The parametric equalizer is divided into four frequency bands: LOW, LOW MID, HIGH MID, and HIGH. When the equalizer is enabled, the following parameters are adjustable:</p> <p>FREQUENCY: Select the center frequency of the band to boost/cut</p> <p>Q: Adjusts the width and slope of the frequency band (measured in octaves)</p> <p>GAIN: Adjustable in 2 dB increments from -6 dB (cut) to +6 dB (boost)</p> <p><b>NOTE:</b> HIGH and LOW are shelf filters, and therefore do not have adjustable Q widths. The HIGH shelf is fixed at 10 kHz; the LOW shelf is fixed at 100 Hz.</p> <p>The graph shows the frequency response of the EQ. The x-axis is Frequency (Hz) on a logarithmic scale from 20 to 20k. The y-axis is dB from -15 to 15. Four bands are shown: LOW (shelf filter), LOW-MID (parametric), HIGH-MID (parametric), and HIGH (shelf filter). The gain is adjustable from -6 dB to +6 dB. The Q width is adjustable for the parametric bands. Selectable frequencies are marked with asterisks.</p>

<b>VLIMIT (Maximum Volume)</b>	<p>Set a value (-3 to -21 dB) to attenuate the highest possible volume level. Turning the volume knob through its entire range of motion still affects volume; the limit simply narrows the range of dB adjustment.</p> <p><b>Note:</b> The VLIMIT does <b>not</b> compress the audio.</p>
<b>BAL MX / BAL ST (Balance)</b>	<p>The behavior of the balance control depends on which mode the bodypack is set to:</p> <p>STEREO: Adjusts the left/right balance</p> <p>MIXMODE: Adjusts the blend between channel one and channel two</p>
<b>INPUT</b>	<p>Line (+4 dBu): Use with mixers and other professional devices that send a line-level signal</p> <p>AUX (-10 dBV): Use with consumer electronic devices, such as MP3 players or computers.</p>

## Utilities

<b>CONTRAST</b>	<p>Customize the display screen contrast by selecting a setting between low and high</p>
<b>LOCK PANEL</b>	<p>Locks all controls except the volume knob to prevent accidental changes to settings</p> <p><b>Lock:</b> Select UTILITIES &gt; LOCK PANEL</p> <p><b>Unlock:</b> Press the exit button and select OFF when the lock setting screen appears. Press enter to confirm.</p>
<b>BATTERY</b>	<p>Displays remaining battery runtime (hours:minutes), temperature, status, cycle count, health, and voltage</p> <p><b>Note:</b> Applies to Shure rechargeable battery only</p>
<b>RESTORE</b>	<p>Restores bodypack to factory default settings</p>
<b>AUTO OFF</b>	<p>Automatically turns off the bodypack after a selectable amount of time (5, 30, or 60 min.) while it is in power-save mode or when connected to a charger with the power on. To restore power to the bodypack, the power switch must be turned off and then on again.</p> <p><b>Note:</b> Shure rechargeable batteries charge fastest when the bodypack is off</p>

## MixMode and Stereo Monitoring

The bodypack can operate in either of the following listening modes:

### Stereo (default)

To operate in stereo mode, enter the menu and select AUDIO > MODE > STEREO .

In stereo mode, audio from channel 1 is heard on the left earphone, while audio from channel 2 is heard on the right earphone. Listening in stereo increases clarity and separation between the sources on each channel.



Left (Channel 1)

Right (Channel 2)

## Adjusting Balance

To adjust the left/right balance, select AUDIO > BAL ST. Use the ▲ ▼ buttons to change the setting.

## MixMode

To operate in MixMode, enter the menu and select AUDIO > MODE > MIXMODE.

In MixMode, the blend between two monitoring mixes (an instrumental mix and a vocal mix, for example) is adjustable. The signal is mono, which means each mix is heard through both the left and right earphones.

## Adjusting mix blend

To adjust the blend between channel 1 and channel 2, enter the menu and select AUDIO > BAL MX. Use the arrow buttons (▲ ▼) to make adjustments.

In this scenario, an instrumental mix is on channel 1 (left) and a vocal mix is on channel 2 (right):

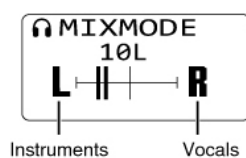

*To hear more of channel one (instruments), shift the balance towards the left.*

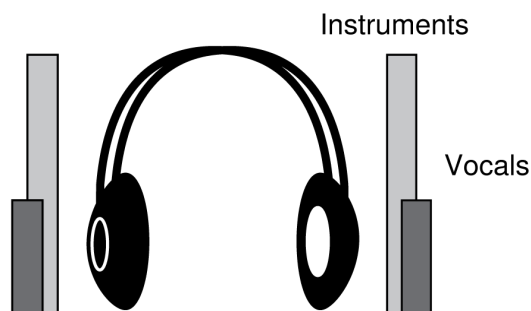

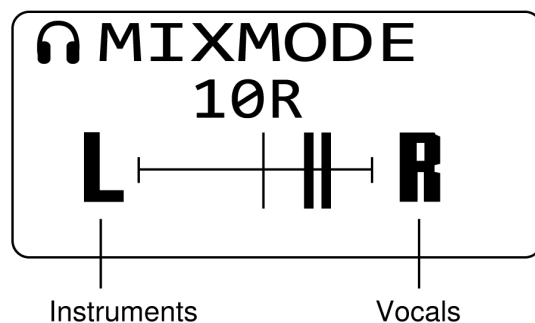

To hear more of channel two (vocals),  
shift the balance towards the right.

*To hear more of channel two (vocals), shift the balance towards the right.*

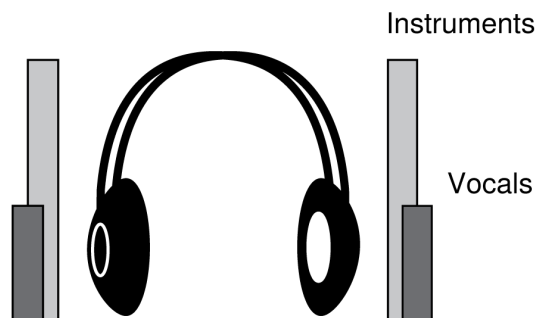

## Balance and Mix Adjustments from the Home Screen

To make quick adjustments to the stereo balance or mixmode blend, use the arrow buttons (▲ ▼) while in the home screen. If necessary, use the lock feature to prevent any accidental adjustments.

## Shure SB900-Series Rechargeable Battery

Shure SB900-series lithium-ion batteries offer a rechargeable option for powering the bodypack. Batteries quickly charge to 50% capacity in one hour and reach full charge within three hours.

Single chargers and multiple bay chargers are available to recharge the Shure batteries.

**Caution:** Only charge Shure rechargeable batteries with a Shure battery charger.

### Single Bay Charger

The SBC-100 single bay charger offers a compact charging solution.

1. Plug the charger into an AC power source or USB port.
2. Insert a battery into the charging bay.
3. Monitor the charging status LEDs until charging is complete.

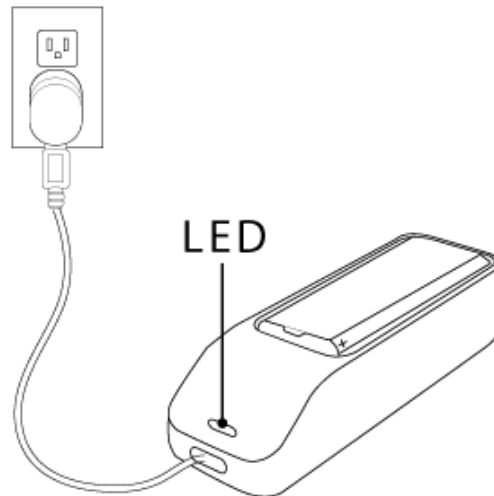

## Charging Status LED

Color	Status
Red	Charging
Green	Charging Complete
Amber Flashing	Fault: check connections and battery
Off	No battery in bay

## Multiple Bay Chargers

Shure offers several models of multiple-bay chargers:

- SBC200 two-bay charger
- SBC210 two-bay charger
- SBC220 two-bay networked charger
- SBC800 eight-bay charger

SBC200 and SBC220 chargers can charge individual batteries or batteries installed in bodypacks.

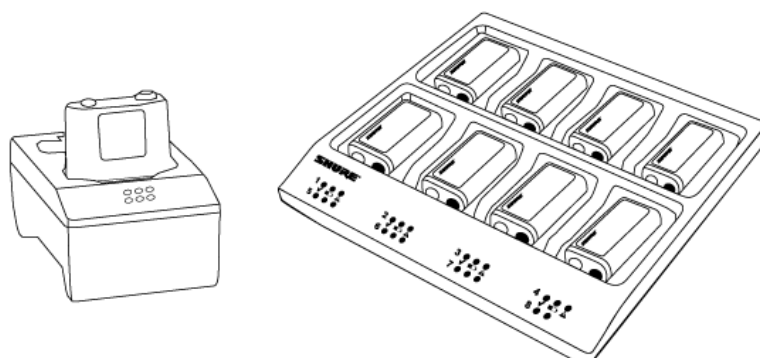

1. Plug the charger into an AC power source.
2. Insert batteries or bodypacks into the charging bay.
3. Monitor the charging status LEDs until charging is complete.

## Charging Status LED

Color	Status
Green	Charging Complete
Green/Red	Charge level above 90%
Red	Charging
Amber Flashing	Fault: check connections and battery
Off	No battery in bay



## Important Tips for Care and Storage of Shure Rechargeable Batteries

Proper care and storage of Shure batteries results in reliable performance and ensures a long lifetime.

- Always store batteries and bodypacks at room temperature
- Ideally, batteries should be charged to approximately 40% of capacity for long-term storage
- During storage, check batteries every 6 months and recharge to 40% of capacity as needed

## Battery Life

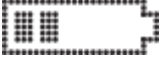
Battery Indicator	Tri-Color Battery LED	Approximate Hours Remaining (h:mm)	
		Alkaline	Shure SB900C Rechargeable Battery
	Green	9:00 to 7:10	11:45 to 7:20
	Green	7:10 to 5:25	7:20 to 5:35
	Green	5:25 to 3:35	5:35 to 3:40

	Green	3:35 to 1:45	3:40 to 1:50
	Amber	1:45 to 0:50	1:50 to 0:55
	Red	< 0:50	< 0:55
<b>Total Battery Life</b>		9:00	11:45

**Note:** Battery life using Energizer™ brand AA Alkaline batteries and the following conditions:

- Receiver audio set to EQ = OFF, V LIMIT = OFF
- Audio output at bodypack: Pink noise at 100 dB SPL in ear with SE425 earphones (impedance at 20 Ω)

**Power-save mode:** When there are no earphones plugged in for 5 minutes, the receiver enters power-save mode to preserve battery life. The LED slowly fades on/off in this mode and continues to display the color that represents the remaining battery life.

## Pin Assignments

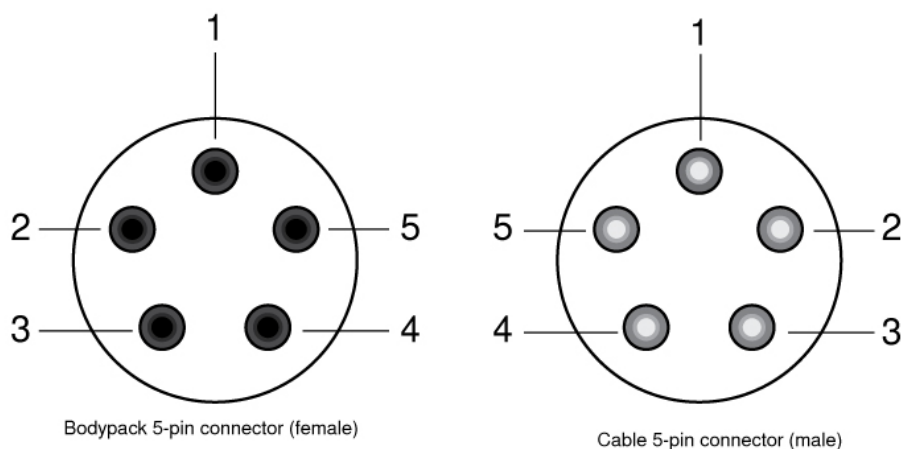

Pin	Signal	Left XLR	Right XLR
1	Shield	1	1
2	+	2	--
3	-	--	3
4	-	3	--
5	+	--	2

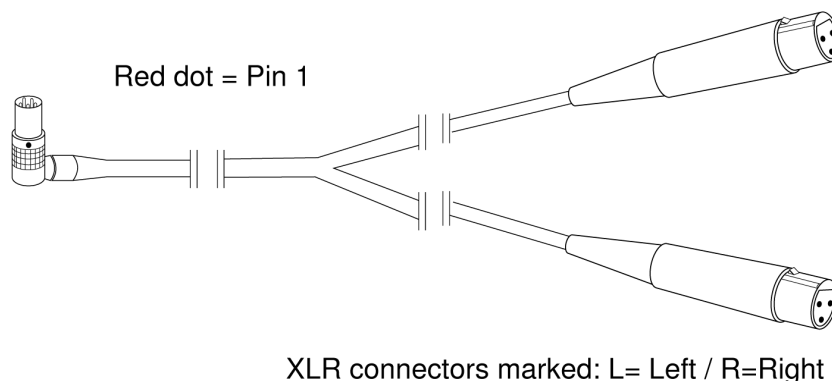

## Optional Accessories and Replacement Parts

- Dual-XLR to 5-pin LEMO cable - PA720
- Shure Lithium-Ion Rechargeable Battery - SB900C
- AA battery adapter - 65A15224
- PS9 battery eliminator - 90A4794
- Dynamic MicroDriver earphones - SE112 or SE215
- High-definition MicroDriver earphones with tuned bass port - SE315
- High-definition earphones with dual MicroDrivers - SE425
- High-definition earphones with triple MicroDrivers - SE535
- High-definition earphones with quad MicroDrivers - SE846

## Specifications

### Audio Frequency Response

20 Hz–20 kHz ( $\pm 3$  dB)

### Signal-To-Noise Ratio

*A-Weighted*

98 dB (typical)

### Total Harmonic Distortion

*@ 1 kHz, typical*

<0.2%

### Channel Separation

*@ 1 kHz*

>55 dB

### Operating Temperature

-18°C to +63°C

## Minimum Load Impedance

9.5  $\Omega$

## Dimensions

99 x 66 x 23 mm (3.9 in. x 2.6 in. x 0.9 in.) H x W x D

## Net Weight

196 g (6.6 oz.) (with batteries)

## Battery Life

9 hours (continuous use) AA batteries

---

# Certifications

This product meets the Essential Requirements of all relevant European directives and is eligible for CE marking.

Meets essential requirements of the following European Directives:

- Low Voltage Directive 2014/35/EU
- EMC Directive 2014/30/EU
- WEEE Directive 2012/19/EU, as amended by 2008/34/EC
- RoHS Directive EU 2015/863

*Note: Please follow your regional recycling scheme for batteries and electronic waste*

**Industry Canada ICES-003 Compliance Label:** CAN ICES-3 (B)/NMB-3(B)

**Industry Canada ICES-003 Compliance Label:** CAN ICES-3 (B)/NMB-3(B)

The CE Declaration of Conformity can be obtained from Shure Incorporated or any of its European representatives. For contact information please visit [www.shure.com](http://www.shure.com)

The CE Declaration of Conformity can be obtained from: [www.shure.com/europe/compliance](http://www.shure.com/europe/compliance)

Authorized European representative:

Shure Europe GmbH

Global Compliance

Jakob-Dieffenbacher-Str. 12

75031 Eppingen, Germany

Phone: +49-7262-92 49 0

Email: [info@shure.de](mailto:info@shure.de)

[www.shure.com](http://www.shure.com)

**Note:** EMC conformance testing is based on the use of supplied and recommended cable types. The use of other cable types may degrade EMC performance.

Please follow your regional recycling scheme for batteries, packaging, and electronic waste.