

# CITY THEATRICAL

NEW YORK • LONDON

An **Environmental Lights** Company

## Multiverse® 5x2.5A Dimmer, 2.4GHz P/N 5943

### User Manual

Rev 2.0

© 2025 City Theatrical, LLC

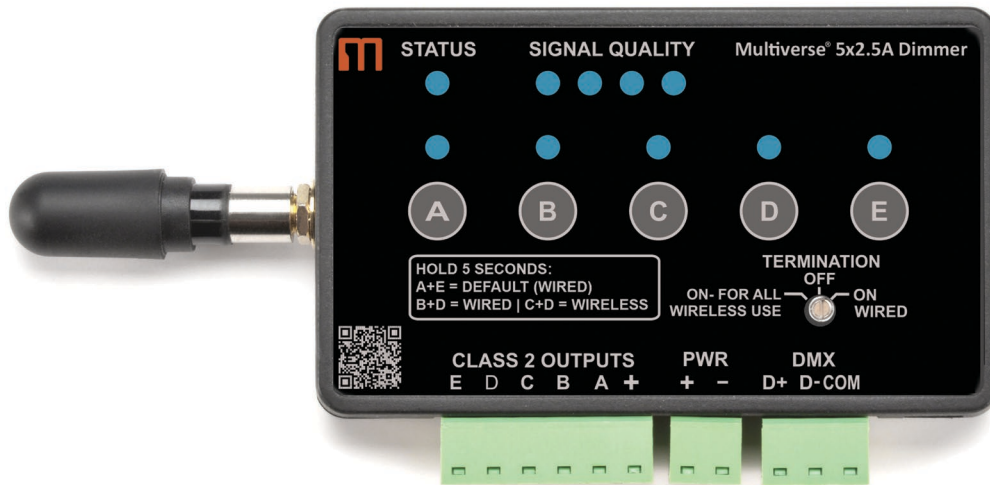

Multiverse® Transceivers are covered by U.S. Patent # 7,432,803 and other U.S and foreign patents pending.

Made in USA

**US HEADQUARTERS**  
475 BARELL AVENUE  
CARLSTADT, NEW JERSEY 07072  
TEL 800 230 9497 / 201 549 1160  
FAX 201 549 1161

[www.citytheatrical.com](http://www.citytheatrical.com)

**LONDON OFFICE**  
UNIT 1-3 WYVERN ESTATE, BEVERLEY WAY  
NEW MALDEN, SURREY KT3 4PH  
TEL +44 (0) 20 8949 5051  
FAX +44 (0) 20 7183 6061

## Table of Contents

---

1	Foreword .....	2
2	Compliance .....	3
3	Introduction .....	4
4	Specifications .....	7
5	Configuration .....	8
6	Troubleshooting .....	17

## List of Tables

---

Table 1: Part Numbers .....	4
Table 2: Physical Characteristics .....	7
Table 3: Troubleshooting Guide .....	18
Table 4: Accessories .....	19

## List of Figures

---

Figure 1: Front and Back Detail .....	5
Figure 2: Mounting .....	6
Figure 3: Multiverse SHoW ID .....	15
Figure 4: Wired Mode .....	16
Figure 5: Wireless Mode .....	17

## 1 Foreword

---

### 1.1 Safety Notice

---

- This product is designed for use in dry locations only. Exposure to rain or moisture may cause damage to the transceiver and increase risk of electrical shock.
- Check all external wiring before applying power.

## 2 Compliance

---

This device complies with Part 15 of the Federal Communications Commission (FCC) Rules. Operation is subject to the following two conditions:

- (1) This device may not cause harmful interference.
- (2) This device must accept any interference received, including interference that may cause undesired operation.

CAUTION: Changes or modifications to this unit not expressly approved by the party responsible for compliance could void the user's authority to operate this equipment.

### 2.1 IC Statement

---

This device complies with Industry Canada's license-exempt RSSs. Operation is subject to the following two conditions:

- (1) This device may not cause interference; and
- (2) This device must accept any interference, including interference that may cause undesired operation of the device.

Le présent appareil est conforme aux CNR d'Industrie Canada applicables aux appareils radio exempts de licence. L'exploitation est autorisée aux deux conditions suivantes :

- (1) l'appareil ne doit pas produire de brouillage, et
- (2) l'utilisateur de l'appareil doit accepter tout brouillage radioélectrique subi, même si le brouillage est susceptible d'en compromettre le fonctionnement.

### 3 Introduction

---

Multiverse 5x2.5A Dimmer 2.4GHz (P/N 5943) is a constant voltage, five-output dimmer that can be controlled wirelessly (with Multiverse Technology), or with wired DMX. This dimmer provides 20-bit PWM resolution and six DMX personality options (8-bit (5ch), 16-bit (10ch), 8-bit Tunable White Single (2ch), 16-bit Tunable White Single (4ch), 8-bit Tunable White (4ch), and 16-bit Tunable White (8ch)) for extremely smooth dimming at the low end of the dimming curve. It uses detachable input and output connectors to make wiring easy. Configuration is performed using RDM, such as with a City Theatrical DMXcat<sup>®</sup>, or with City Theatrical's USB Configuration program for PC/Mac. A mounting bracket is included with the Dimmer to allow easy mounting to scenery. This dimmer is designed and built in the USA by City Theatrical. It pairs perfectly with QolorFLEX 5-in-1 LED Tape for ideal use in props and costumes, or for areas where space is a concern.

#### 3.1 Features

---

- Wireless or wired DMX input
- Wired DMX output
- Mounting bracket included
- Compatible with Multiverse 2.4GHz and SHoW DMX Neo SHoW IDs
- DMX termination selector switch
- Per channel level indicator lights
- Per channel PWM frequency, response time, and curve selections
- Per channel bump buttons, with disable function
- Per channel offsets to balance the point at which each dimmer first turns on (important for perfect low-end balance)
- DMX data loss options
- Micro USB port for firmware updates and configuration
- Class 2 outputs
- Error detection and signal light for short circuits, over current, over/under voltage, over temperature

#### 3.2 Part Numbers

---

*Table 1: Part Numbers*

Part #	Description
5943	Multiverse 5x2.5A Dimmer 2.4GHz

# 5943 Multiverse Dimmer 5x2.5A 2.4GHz

## 3.3 Product Detail

### Status Light

Green for wired / Blue for wireless;  
 Solid for DMX present  
 Blinking when no DMX present;  
 Blinking Red for fault codes.

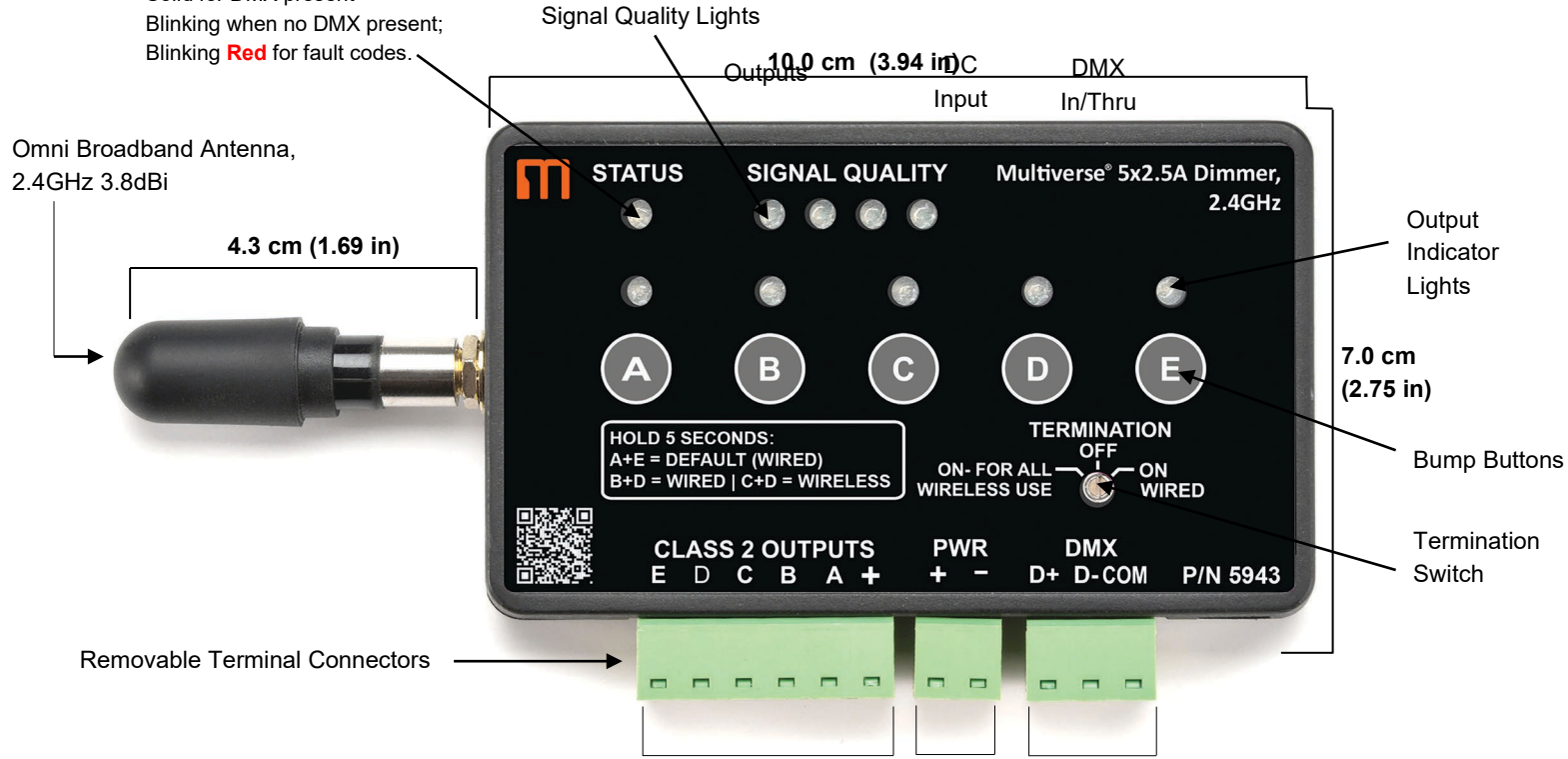

### Error Codes

Number of blinks:

- 1 Short circuit
- 2 Output overcurrent (>4A on any output)
- 3 Input overcurrent (>12.5A on total device)
- 4 Over temperature on any output
- 5 Under voltage
- 6 Over voltage



## 5943 Multiverse Dimmer 5x2.5A 2.4GHz

### Mounting

---

A plastic mounting clip is included with each Multiverse 5x2.5A Dimmer. Two mounting holes are provided for mounting to scenery. Simply insert the bottom end of the dimmer into the mounting clip and press it into the flexible holding clips on top.



*Figure 2: Mounting*

## 4 Specifications

*Table 2: Physical Characteristics*

Specifications	Description
Frequency	2.4GHz
Universe(s)	1
Size (with antenna)	5 5/8" (14.3cm) L x 2 3/4" (7.0cm) W x 5/8" (1.6cm) H
Weight	0.15 lbs. (0.07 Kg)
Operating Temperature	0°C - 35°C
Construction	NEMA 4 IP20 ABS Plastic
Connections	Pluggable connectors
Mounting	Plastic bracket included

Dimming Information	
Voltage Range	5 - 30 VDC
PWM Frequencies (Hz)	60, 1.2K, 2.4K, 5K, 12K, 24K, 50K
Power	4A/channel maximum; 12.5A total
Control Resolution	6 DMX Personality options, including: <ul style="list-style-type: none"> <li>• 8-bit (5ch)</li> <li>• 16-bit (10ch)</li> <li>• 8-bit Tunable White Single (2ch)</li> <li>• 16-bit Tunable White Single (4ch)</li> <li>• 8-bit Tunable White (4ch)</li> <li>• 16-bit Tunable White (8ch)</li> </ul>
PWM Resolution	20-bit

Radio Information	
Broadcast Power	Antenna dependent; 100mW EIRP
Broadcast Modes	Adaptive, Full, Low, Mid, High, Max
Ethernet Protocols	N/A
SHow IDs	Multiverse: 147; Neo: 70
Latency	4ms average
RF Sensitivity	-95dBm
Antenna	Omni Broadband Antenna, 2.4GHz 3.8dBi
RDM Features	RDM Proxy, RDM Responder

Product Information	
Firmware	User updateable via micro-USB
Configuration	RDM, City Theatrical USB Configuration Program (PC/Mac)
Use Environment	Indoor
Warranty	One year
Manufacturing Origin	USA
Compliance	CE, RoHS, FCC, ACMA, ARIB, IC

## 5 Configuration

---

### 5.1 Installation

---

The Multiverse 5x2.5A Dimmer 2.4GHz Dimmer requires standard DC power from 5-30VDC. The input voltage must be the same as the load connected to the output ports requires.

Connect your power supply's DC "+" and "-" to the two DC input terminals on the 5943 labelled "PWR" "+" and "-".

Connect the "+" lead(s) of the load device(s) to the "+" "OUTPUT" terminal, and connect the "-" leads of the load device(s) to "A", "B", "C", "D", and "E" "OUTPUT" terminals.

NOTE: Terminal connectors may be detached from the unit for ease of wiring. Check wiring connections carefully before reinserting connectors, and reinsert connectors carefully into their intended positions.

Use the "A", "B", "C", "D", and "E" bump buttons to check your connections prior to applying DMX control.

To set DMX Termination Switch:

- "ON FOR ALL WIRELESS USE"
- "OFF": When used as a wired dimmer and DMX is passing through to another DMX device
- "ON WIRED": When used as a wired dimmer and it is the last device in a DMX chain

### 5.2 Multiverse, DMX, and RDM Settings

---

#### **Important setup information!**

Unit ships defaulted to "wired" mode, and RDM configuration begins in that mode.

The status light shows green for wired mode, blue for wireless mode, and red for fault detected (see pages 5 or 18 for fault codes).

Revert to wired mode and reset **all** factory defaults by holding down the "A" and "E" bump buttons together for five seconds until the "STATUS" and "SIGNAL QUALITY" lights flash in unison.

Revert to wireless mode **without changing any other settings** by holding down the "C" and "D" bump buttons together for five seconds until the "STATUS" and "SIGNAL QUALITY" lights flash in unison.

## 5943 Multiverse Dimmer 5x2.5A 2.4GHz

### Factory Default Settings

#### **DMX tab**

- RDM Traffic Enabled
- DMX Port Label: Label
- Universe 1
- DMX Address 1
- DMX Personality 8-Bit (5ch)

#### **Dimmer tab**

- Bump Buttons Enabled
- Apply to All: No
- Device Label: Default Dim 1 Label
- Curve Logarithmic (LED)
- Output Response Time 100ms Ramp Time
- Modulation Frequency 5000Hz-LED
- Control Offset 0

#### **Multiverse Tab**

- DMX Input Mode Wired
- SHoW ID 24250
- Antenna Selection Omni
- Output Power Max
- SHoW Key 0

#### **Info**

- DMX Fail Mode: Hold last look before changing to a level: Infinite  
Hold level before blacking out: Infinite

### **Setup**

#### **To configure as a WIRED device using an RDM controller:**

Start by connecting an XLR5M to three position Phoenix jumper, such as City Theatrical **PN5950 XLR5M and XLR5F to Three Position Phoenix Connector Female, 6"**, or one that you craft yourself, so you can attach an RDM controller such as a City Theatrical DMXcat.

Using RDM, discover your 5943.

#### **DMX Tab**

- Enable or disable RDM traffic downstream of device
- Set DMX Port Label (user selectable name)
- Set Universe (must match between Transmitter and 5943)
- Set DMX Address
- Six DMX Personality options, including:
  - 8-bit (5ch)
  - 16-bit (10ch)
  - 8-bit Tunable White Single (2ch)

## 5943 Multiverse Dimmer 5x2.5A 2.4GHz

- 16-bit Tunable White Single (4ch)
- 8-bit Tunable White (4ch)
- 16-bit Tunable White (8ch)

### Dimmer Tab

- Enable or disable bump buttons
- Select "Apply to All" to apply your choices to all five Dimmers. **Note: This must be selected before making any setting changes.**
- Set Device Label (user selectable name)
- Select Dimmer Curve (changes the slope of the dimmer curve, see pg. 12 for all choices)
- Select Output Response Time (lengthens the dimmer response time to achieve smoother dimming, see pg. 12 for all choices)
- Modulation Frequency (sets the dimming PWM to prevent interference or flickering with film and video camera shutters, see pg. 12 for all choices)
- Set Control Offset (At very, very low levels in slow fades, the LED emitters may energize at different times. If for instance the red circuit is turning on before green and blue, you can offset the time that the green and blue outputs begin to fade by raising the value of the Control Offset above zero. Range is -32,768 to +32,767. Try an offset of 100 first and adjust from there.

Apply DMX and verify system is working.

See page 13 for information on Sensors Tab and Info Tab.

### **To configure as a WIRELESS device using an RDM controller:**

Start by connecting an XLR5M to three position Phoenix jumper, such as City Theatrical **P/N5950 XLR5M and XLR5F to Three Position Phoenix Connector Female, 6"**, or one that you craft yourself, so you can attach an RDM controller such as a DMXcat.

If starting from default mode, your 5943 will be in Wired mode, and the green status light will be blinking.

Using RDM, discover your 5943.

### DMX Tab

- Enable or disable RDM traffic downstream of device
- Set DMX Port Label (user selectable name)
- Set Universe (must match between Transmitter and 5943)
- Set DMX Address
- Six DMX Personality options, including:
  - 8-bit (5ch)
  - 16-bit (10ch)
  - 8-bit Tunable White Single (2ch)
  - 16-bit Tunable White Single (4ch)
  - 8-bit Tunable White (4ch)
  - 16-bit Tunable White (8ch)

## 5943 Multiverse Dimmer 5x2.5A 2.4GHz

### Dimmer Tab

- Enable or disable bump buttons
- Select “Apply to All” to apply your choices to all five Dimmers.
- Set Device Label (user selectable name)
- Select Dimmer Curve (changes the slope of the dimmer curve, see pg. 12 for all choices)
- Select Output Response Time (lengthens the dimmer response time to achieve smoother dimming, see pg. 12 for all choices)
- Modulation Frequency (sets the dimming PWM to prevent interference or flickering with film and video camera shutters, see pg. 12 for all choices)
- Set Control Offset (At very, very low levels in slow fades, the LED emitters may energize at different times. If for instance the red circuit is turning on before green and blue, you can offset the time that the red and green outputs begin to fade by raising the value of the Control Offset above zero. Range is -32,768 to +32,767.

### Multiverse Tab

- (skip setting DMX Input Mode for now)
- Select SHoW ID (Choose any 2.4GHz SHoW ID to match your Transmitter settings) See page 15 or Multiverse Transmitter, Node, SHoW Baby, or SHoW DMX Neo products manuals for more information on SHoW IDs.
- Select Antenna Setting if not default Omni (other choices are Internal, Panel, Yagi)
- Select Output power if not default Max (other choices are Low, Medium, High)
- Choose a SHoW Key, if desired.

NOTE: Universe, SHoW ID and SHoW Key must match between Transmitter and 5943.

- Now change the DMX Input Mode from the default Wired, to Wireless. At this point, you will lose control over the 5943 since it is now a wireless device and will receive an error message, the STATUS light will turn blue and will be blinking if there is no DMX being received, and will be solid blue if you have a Transmitter already properly set and operating nearby.

Apply DMX through a transmitter set on the same SHoW ID, SHoW Key, and Universe, and verify system is working. Note: RDM traffic needs to be enabled at the transmitter to view the wireless 5943 in RDM.

### To configure as a WIRED or WIRELESS device using the City Theatrical USB

**Configurator controller:** Download the City Theatrical USB Configurator from the 5943 webpage on the CTI website, and install the program on your computer (Mac or PC). Connect your computer to your 5943 via a USB to micro-USB cable. Select your serial port from the Serial Port tab in the USB Configurator program. Follow the instructions (above) as you would for using an RDM controller for wired or wireless use.

## 5.3 RDM Settings

---

### 5943 Menu Descriptions

The full 5943 menu is reachable through RDM via the City Theatrical DMXcat app, other RDM controllers, or the City Theatrical USB Configurator. The following screenshots show what the menus look like in the DMXcat app.

## 5943 Multiverse Dimmer 5x2.5A 2.4GHz

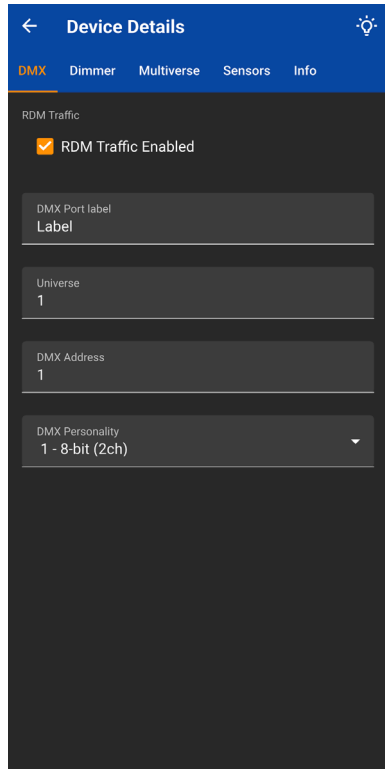

### DMX Screen

Use the “Light Bulb” icon to do an RDM identify command to the 5943. All indicator lights will flash.

Enable/disable RDM traffic downstream of the 5943.

Relabel the DMX port on the 5943.

Choose universe number.

Choose starting DMX address for the five dimmers.

Choose from six DMX Personalities, including:

- 8-bit (5ch)
- 16-bit (10ch)
- 8-bit Tunable White Single (2ch)
- 16-bit Tunable White Single (4ch)
- 8-bit Tunable White (4ch)
- 16-bit Tunable White (8ch)

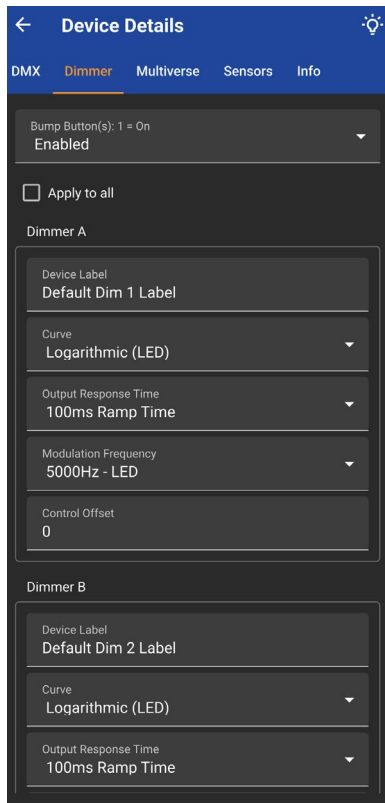

### Dimmer Screen

Enable/Disable Bump Buttons.

Apply changes made to all Dimmers.

Edit Label.

Choose Dimming Curve (default is Logarithmic (LED); other choices are Square Law (Incan); Linear; and Non-Dim).

Choose Output Response Time (default is 100ms ramp time; other choices range from 10ms to 400ms).

Choose Modulation Frequency (default is 5000Hz-LED; other choices range from 60Hz Incan to 50000Hz LED, including 1200Hz Candle mode).

Choose Control Offset (default is 0)

## 5943 Multiverse Dimmer 5x2.5A 2.4GHz

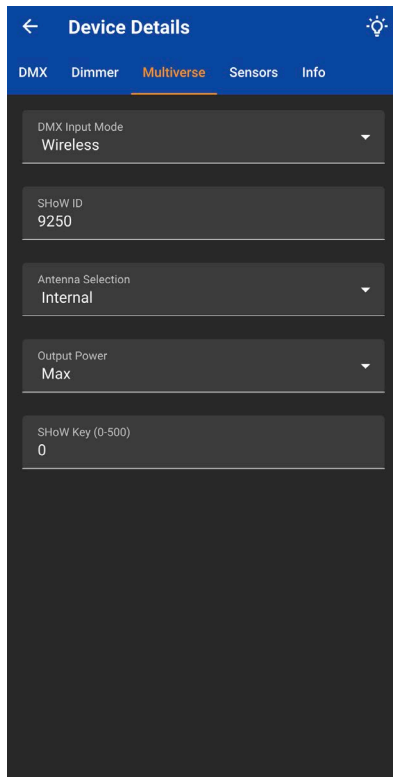

### Multiverse Screen

Select Wired or Wireless operation (default is Wired).

Select SHoW ID (default is 24250) See information on page 15 about SHoW ID. SHoW ID must match on Transmitter and receiving devices.

Select Antenna in use (default is Omni).

Select Output Power (default is Max).

Select SHoW Key (default is 0) If optional SHoW Key is used, it must match on Transmitter and all receiving devices.

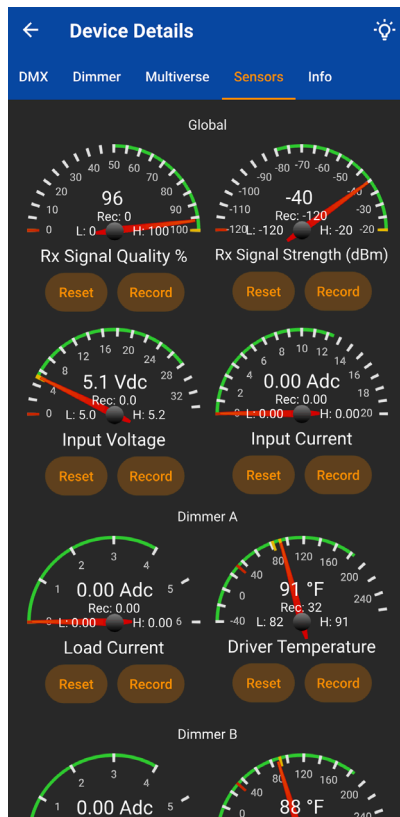

### Sensors Screen

Use the Sensors screen to monitor various data collected by the Dimmer.

Press record to record a level for future comparison. Press reset to reset high and low values.

## 5943 Multiverse Dimmer 5x2.5A 2.4GHz

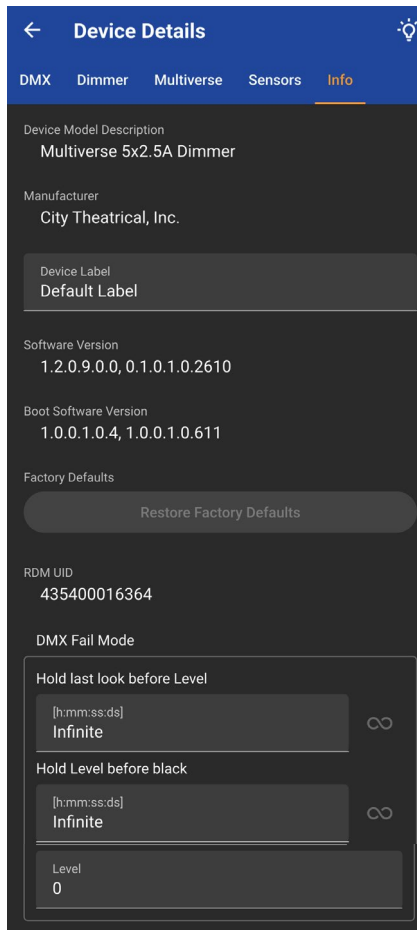

### Info Screen

Shows Device Model Description

Shows City Theatrical as manufacturer (made in USA).

Device Label (user editable).

Shows Software Version.

Shows Bootloader Software Version.

Restore all configuration options to their factory default settings.

Shows RDM UID.

DMX Fail Mode: Choose what action device will take upon loss of DMX.

Hold last look for a user selectable amount of time, before changing to a user selectable level (set below).

Hold user selectable level for a user selectable amount of time before blacking out.

Set level

## 5.4 Multiverse SHoW IDs

### Multiverse SHoW ID Example: **24302**

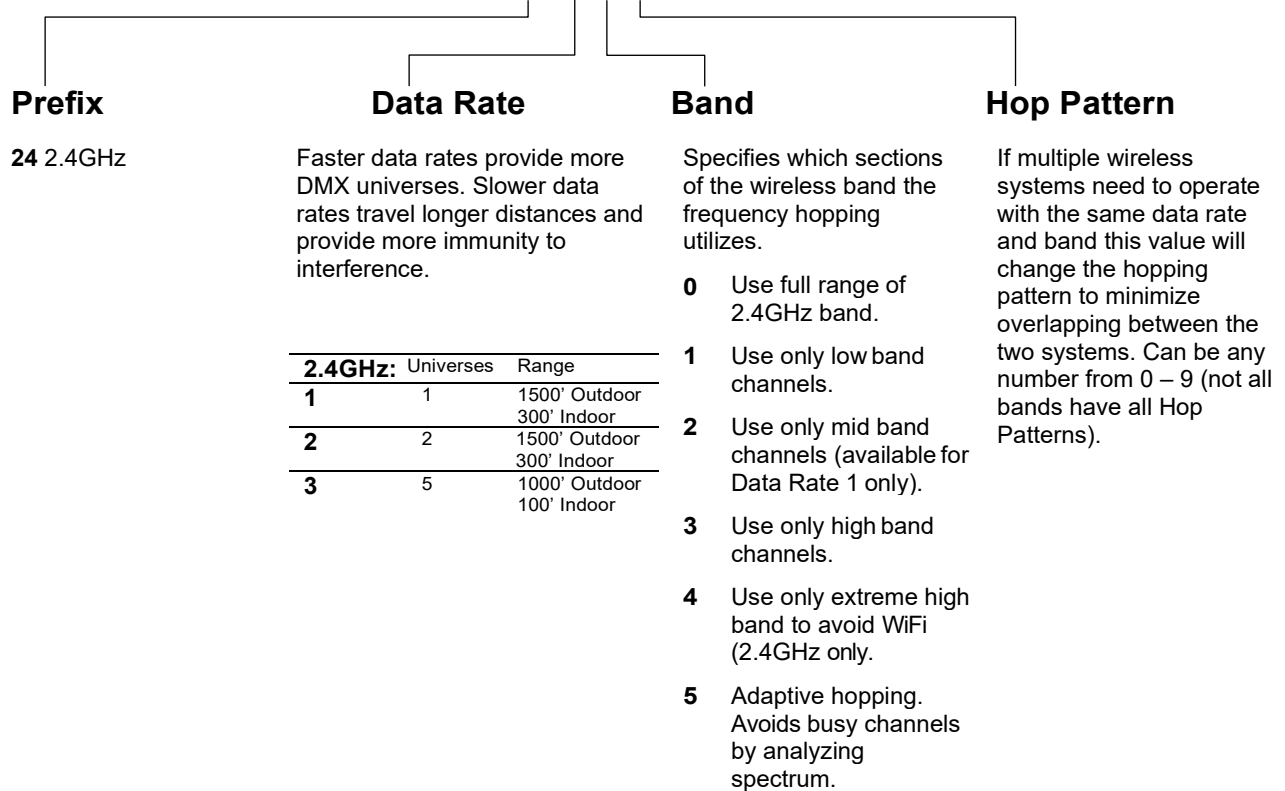

Note: Not all combinations of digits are possible and unused numbers are reserved for future use.

**Figure 3: Multiverse SHoW ID**



# 5943 Multiverse Dimmer 5x2.5A 2.4GHz

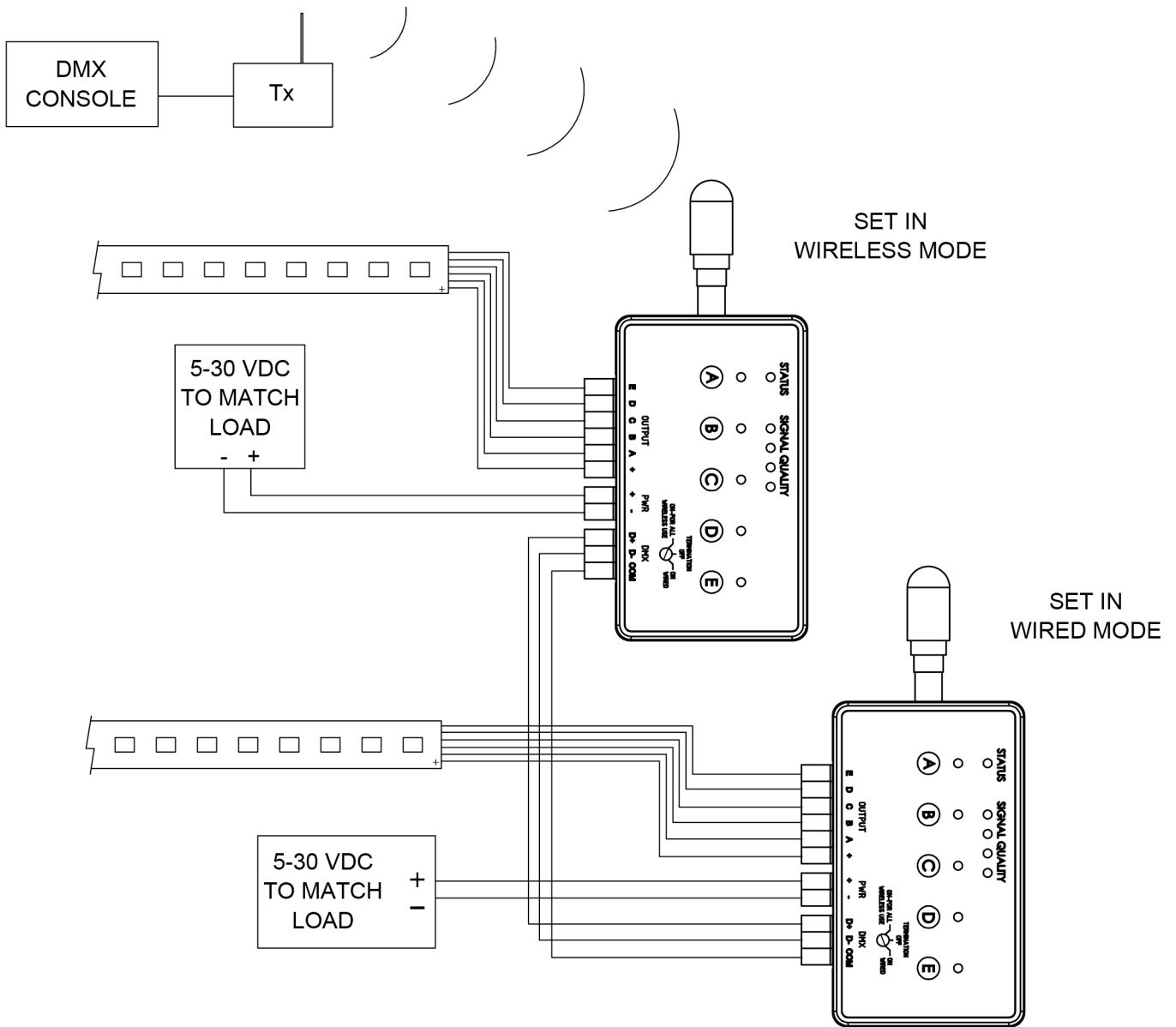

Figure 5: Wireless Mode

## 6 Troubleshooting

*Table 3: Troubleshooting Guide*

Symptom	Solution(s)
Unit does not power up.	Check that power supply is outputting voltage.
	Check polarity of DC voltage connection from power supply to dimmer.
Unit powers up but can't be controlled.	Use bump buttons to check that output is wired correctly.
	If operating in <b>wireless mode</b> , check that SHoW ID and SHoW Key (if used) and universe match your Transmitter and that DMX present light on dimmer is solid blue.
	Check that "Wireless" has been selected on Multiverse tab of setup screen.
	If operating in <b>wired mode</b> , check that the DMX present light on dimmer is solid green. Check that "Wired" has been selected on Multiverse tab of setup screen.
Additional troubleshooting:	Check the starting DMX address, and that the lighting controller is outputting that address. Check console patch.
	For wireless systems, SHoW ID, SHoW Key (if used) and universe must match on Transmitter and all receiving devices.
	If using a wired DMX connection, check polarity of connections carefully using a meter. Pin 1 = common, Pin 2 =DMX "- ", PIN 3 =DMX "+ "
Check LED tape connections carefully. Some tapes use the red wire to designate the "+" connection, and some use the black wire. Check the circuit board of the LED tape carefully to confirm. When wired correctly, the bump buttons will light each circuit before DMX is applied. Troubleshoot tape connection problems first before troubleshooting DMX problems.	Dimmer trouble codes: Status light will <b>blink red</b> when problems are encountered.

## 5943 Multiverse Dimmer 5x2.5A 2.4GHz

### 6.1 Firmware Updates

---

City Theatrical issues firmware updates occasionally to add features or to fix bugs. The firmware version is found on the Info section of the 5943. Firmware updates are found on the CTI website on the 5943 Downloads tab. Update instructions and the firmware files themselves are found in that download.

### 6.2 Accessories

---

*Table 4: Accessories*

P/N	Name
5950	XLR5M and XLR5F to Three Position Phoenix Connector (5943) Female, 6"
5951	Phoenix Connector, Six Position for 5943, Female
5952	Phoenix Connector, Three Position for 5943, Female
5668	Phoenix Connector, Two Position for 5943, Female
5954	Mounting Plate for 5943
5984	Antenna, Omni, 900MHz/2.4GHz 1.8dBi/3.8dBi Stubby, Dual Band

### 5.3 Customer Service

---

**City Theatrical, Inc.**

475 Barell Avenue  
Carlstadt, NJ 07072  
USA

Phone: (800) 230-9497 or (201) 549-1160

Fax: (201) 549-1161

[support@citytheatrical.com](mailto:support@citytheatrical.com)

**City Theatrical Ltd.**

Office 31, Units 1-3, Wyvern Estate, Beverley Way  
New Malden, Surrey KT3 4PH  
United Kingdom

Phone: +44 (0) 20 8949 5051

[support@citytheatrical.com](mailto:support@citytheatrical.com)

For additional resources and documentation, please visit our website: [www.citytheatrical.com](http://www.citytheatrical.com)

**5943 Multiverse Dimmer 5x2.5A 2.4GHz**

**Appendix A. DMX Slot Information for Personalities for 5943 Dimmers**

Personality	Description	DMXa ddr	DMXa ddr + 1	DMXa ddr + 2	DMXa ddr + 3	DMXa ddr + 4	DMXa ddr + 5	DMXa ddr + 6	DMXa ddr + 7	DMXa ddr + 8	DMXa ddr + 9
1	8-bit (5ch)	Dim A	Dim B	Dim C	Dim D	Dim E					
2	16-bit (10ch)	Dim A	Dim A Fine	Dim B	Dim B Fine	Dim C	Dim C Fine	Dim D	Dim D Fine	Dim E	Dim E Fine
3	8-bit Tunable White Single (2ch)	Dim A /B Intensity	Dim A/B Color Temp								
4	16-bit Tunable White Single (4ch)	Dim A/B Intensity	Dim A/B Intensity Fine	Dim A/B Color Temp	Dim A/B Color Temp Fine						
5	8-bit Tunable White Dual (4ch)	Dim A/B Intensity	Dim A/B Color Temp	Dim C/D Intensity	Dim C/D Color Temp						
6	16-bit Tunable White Dual (8ch)	Dim A/B Intensity	Dim A/B Intensity Fine	Dim A/B Color Temp	Dim A/B Color Temp Fine	Dim C/D Intensity	Dim C/D Intensity Fine	Dim C/D Color Temp	Dim C/D Color Temp Fine		