

MAC Aura Raven XIP

User Manual
with Safety and Installation Manual



Martin[®]

User documentation revision information

Revision C

User documentation now includes warnings about IP protection rating when using the Beamshaper accessory. Beamshaper accessory installation instructions are now supplied with the accessory only.

Revision B

First public release.

Covers fixture firmware v. 1.0.0.

©2024-2025 HARMAN PROFESSIONAL DENMARK ApS. All rights reserved. Features, specifications and appearance are subject to change without notice. HARMAN PROFESSIONAL DENMARK ApS and all affiliated companies disclaim liability for any injury, damage, direct or indirect loss, consequential or economic loss or any other loss occasioned by the use of, inability to use or reliance on the information contained in this document. Martin is a registered trademark of HARMAN PROFESSIONAL DENMARK ApS registered in the United States and/or other countries.

HARMAN PROFESSIONAL DENMARK ApS, Olof Palmes Allé 44, 8200 Aarhus N, Denmark
HARMAN PROFESSIONAL, INC. 8500 Balboa Blvd., Northridge CA 91325, USA

www.martin.com

MAC Aura Raven XIP User Manual, Safety/Installation Manual, English, P/N 5147260-00 Revision C

Table of contents

Introduction.....	5
Operating the fixture.....	5
Applying mains power.....	6
Cold starting.....	6
Connecting to data.....	6
Data via DMX cable.....	6
Data via Ethernet cable.....	7
Control options.....	8
DMX.....	8
P3 creative LED and video.....	8
RDM.....	9
Effects.....	10
Shutter and strobe effects.....	10
Dimming.....	10
Color mixing.....	10
Virtual color wheel.....	10
Zoom.....	10
CTC.....	10
Green/Magenta shift.....	11
FX: Pre-programmed effects macros.....	11
LED PWM frequency.....	11
Pan and Tilt.....	11
Rotating Beamshaper accessory.....	11
Fixture setup.....	12
Fixture ID.....	12
DMX control mode.....	12
DMX address.....	12
DMX universe.....	12
Network settings.....	12
Pan/tilt inversion.....	13
Pan/tilt speed.....	13
Effects speed.....	13
Pan and tilt limits.....	13
Pan and tilt feedback.....	14
Dimming curves.....	14
Tungsten emulation.....	14
Color mode.....	14
Video tracking.....	15
Cooling mode.....	15
Outdoor operation and drying out function.....	15
DMX reset enable.....	16
Display sleep.....	16
Display rotation (inversion).....	16
Display intensity.....	16
Display contrast.....	16
Error display mode.....	16
Viewing stored status (error and warning) messages.....	17
Hibernation mode.....	17

Standalone operation	17
Storing and recalling custom settings	18
Resetting to factory defaults	18
Fan cleaning	18
DMX LIVE signal monitoring	19
Manual control	19
Fixture test sequences	19
Resetting the fixture	20
Displaying test patterns	20
'Identify device' signal	20
Fixture information readouts	21
Calibration	22
Loading factory default calibration values	23
Adjustment menu (Martin Global Service only)	23
Service log	24
Control panel	25
Using the control panel	25
Status LED	25
Battery power	26
Shortcuts	26
Settings stored permanently	26
Activating service mode	26
Using RDM	27
Martin Companion® and RDM	27
RDM functions	28
Using NFC	32
Control menus	33
Pixel layout	40
DMX protocols	41
Compact DMX Mode	41
Basic DMX Mode	44
Extended DMX Mode	47
Ludicrous DMX Mode	48
Plaid DMX Mode	49
Compact Direct DMX Mode	50
Control/Settings DMX channel	51
FX	53
Effects types	53
FX table	55
Pan/tilt and zoom orientation guide	61
Service messages	63
Accessories and service procedures	68
Uploading new firmware	68
Installing a UCM (Universal Connect Module)	69

Introduction



Warning! Before installing, operating or servicing the MAC Aura Raven XIP lighting fixture, read the latest version of the fixture's Safety and Installation Manual, paying particular attention to the Safety Precautions section. The Safety and Installation Manual is supplied with the fixture and included at the back of this user manual. The latest version is also available for download from the MAC Aura Raven XIP area of the Martin® website at www.martin.com.

Important! Full specifications for MAC Aura Raven XIP fixtures and accessories are available in the MAC Aura Raven XIP area of the Martin® website at www.martin.com.

Thank you for selecting the MAC Aura Raven XIP lighting fixture from Martin.

This User Manual is a supplement to the Safety and Installation Manual that is supplied with the fixture and attached to the back of this User Manual. The User Manual contains information that is mainly of interest for lighting designers and operators, whereas the Safety and Installation Manual contains important information for all users, especially installers and technicians.

We recommend that you check the Martin website regularly for updated documentation. We publish revised versions each time we can improve the quality of the information we provide and each time we release new firmware with changes or new features. Each time we revise this guide we list any important changes on page 2 so that you can keep track of updates.

The output of LEDs, like all light sources, changes gradually over many thousands of hours of use. If you require products to perform to very precise color specifications, you may eventually need to make small readjustments at the lighting controller.

The MAC Aura Raven XIP is a premium moving head wash light featuring a Beam effect and a pixelated Aura backlight effect. It offers full pixel control with video mapping capabilities onto the Beam, Aura, or both. It is Martin's latest addition to the MAC Aura family of workhorse wash lights, with close to zero compromises in weight, size, and aesthetics due to Martin's smart outdoor-capable design. It raises the bar for optical quality, featuring an even wash field with soft edge, minimal stray light, and high intensity mid-air beams with improved light engine control.

Operating the fixture

Before applying power to or operating the MAC Aura Raven XIP:

- Read the 'Safety Information' section of the fixture's Safety and Installation Manual that is included at the end of this User Guide, supplied with the fixture and available for download from the Martin website at www.martin.com.
- Check that the installation is safe and secure.
- If the fixture is moved from a cold to a warm environment, remove it from its flightcase or packaging and give it at least two hours to acclimatize before applying power. This will help to avoid damage due to condensation.
- Check that the fixture is in perfect condition. Do not apply power to a fixture that is obviously damaged, or you may create a safety risk and make the damage worse.
- Check that the base is fastened securely so that the torque reaction when the head moves will not cause the base to move.
- Check that the head tilt lock is released.
- Be prepared for the head to move suddenly. Check that there will be no risk of collision with persons or objects.
- Be prepared for the fixture to light up suddenly. Check that no-one is looking at the fixture from close range.
- Check that the voltage and frequency of the power supply match the power requirements of the fixture.

Applying mains power

The fixture does not have an on/off switch. It becomes active as soon as AC mains power is applied at the power input connector. Be prepared for the head to move and for the fixture to suddenly emit bright light.

Each time power is applied to the fixture, it will reset all effects and functions to their home positions. A reset typically takes around 25 seconds.

Cold starting

At +5° C (41° F) and below, the fixture starts up in cold-start mode. In this mode, the current to some motors is increased and reset speed is reduced. This makes sure that the fixture can reset safely without any step loss. After a successful reset, the fixture stays in cold-start mode until it has warmed up. In cold-start mode there is a slight increase in noise from the fixture.

The fixture begins to exit cold-start mode when it reaches an internal temperature of approximately 15° C (59° F). By the time it reaches 20° C (68° F) it has exited cold-start mode completely.

To warm up the fixture as quickly as possible, set LED output to full intensity.

Connecting to data

Warning! Before installing the MAC Aura Raven XIP, read the latest version of the fixture's Safety and Installation Manual that is included at the end of this User Manual, paying particular attention to the 'Safety Precautions' section. Besides important safety information, the Safety and Installation Manual contains instructions for connecting to AC mains power.

When using the fixture outdoors or in any environment where water or humidity is present, use connectors rated minimum IP65.

If independent control of a fixture is required, it must have its own DMX channels. Fixtures that are required to behave identically can share the same DMX address and channels.

The number of fixtures that you can connect to DMX data in a daisy chain is limited by the number of DMX channels required by the fixtures. A maximum of 512 channels is available in one DMX universe. To add more fixtures or groups of fixtures when you no longer have enough DMX channels, add a DMX universe and another daisy-chained link.

The MAC Aura Raven XIP has two pairs of connectors for control data In/Out:

- one pair of locking 5-pin XLR sockets that accept IP65-rated Neutrik TOP (or compatible) connectors, and
- one pair of etherCON sockets that accept IP65-rated Neutrik TOP (or compatible) Ethernet connectors.

All sockets are protected by rubber caps. Keep the rubber caps in place at all times on unused sockets.

Data via DMX cable

The MAC Aura Raven XIP has 5-pin locking XLR sockets for DMX and RDM input and output via DMX cable. The pin-out on both sockets is:

- Pin 1 to shield
- Pin 2 to data 1 cold (-)
- Pin 3 to data 1 hot (+).

Pins 4 and 5 are not used by the fixture but are bridged between input and output sockets. These pins can therefore be used as a pass-through connection for an additional data signal if required.

Tips for reliable data transmission via DMX cable

- Use shielded twisted-pair high-quality DMX cable.
- 24 AWG cable is suitable for runs up to 300 meters (1000 ft). Heavier gauge cable and/or an amplifier is recommended for longer runs.

- Do not use microphone cable, as standard microphone cable does not have the correct impedance and cannot transmit control data reliably over long runs.
- To split the data link into branches, use an optically isolated splitter-amplifier. Use an RDM-compatible splitter-amplifier when using RDM.
- Do not overload the DMX data link. You can connect up to a maximum of 32 devices on a serial DMX link.
- Install a DMX termination plug at the end of the DMX link.

Connecting to data via DMX cable

To connect the fixture to DMX and/or RDM data carried over DMX cable:

1. Connect the DMX data output from the controller to the fixture's data input (male XLR) socket using good-quality DMX cable.
2. Run DMX cable from the fixture's data output (female XLR) socket to the data input of the next fixture and continue until the link is complete.
3. Terminate the data link by connecting a 120 Ohm, 0.25 Watt resistor between the data 1 hot (+) and cold (-) conductors at the end of the link. If the link is divided into branches using a DMX splitter, terminate each branch of the link.

Data via Ethernet cable

The MAC Aura Raven XIP has etherCON data sockets that support Art-Net, sACN and Martin P3. Either socket can be used for input and the other socket used for throughput. The etherCON data sockets have a fail-safe bypass feature. This means that the fixture will relay a data signal from the socket used for input to the socket used for throughput even if power to the fixture is shut down or lost.

Tips for reliable data transmission via Ethernet cable

- Use shielded twisted-pair Ethernet cable of type S/UTP, SF/UTP, S/STP or SF/STP only. The cable must be rated Cat 5e or better.
- The cable shield must be electrically connected to connector housings, and the other devices on the data link must also support shielded connections.
- The MAC Aura Raven XIP is compatible with 10/100 Mbit Ethernet only. Do not connect the fixture to a network port or device that is fixed to Gigabit Ethernet speed. If you need to integrate an MAC Aura Raven XIP in a Gigabit Ethernet network, use a network switch to allow the link towards the fixture to operate at 100 Mbit/s Ethernet speed.
- To split the data link into branches, use a standard network switch that is able to operate at 100 Mbit/s towards the fixtures.
- Even though every fixture has a fail-safe bypass mechanism and minimal latency insertion, we recommend that you avoid connecting more than 50 devices in a single daisy-chain or branch.
- Unlike DMX cable, Ethernet cable does not require termination at the end of a daisy-chain of fixtures.

Connecting to data via Ethernet cable

To connect the fixture to Art-Net, sACN or Martin P3 via Ethernet cable:

Connect the Ethernet cable to either of the fixture's etherCON data sockets.

Run Ethernet cable from the fixture's other etherCON data socket to a data socket on the next fixture.

Continue connecting data sockets as described above until the link is complete.

Fail-safe connection

The fixture has a fail-safe network connection. If the fixture loses power or if you shut it down, it will continue to relay an Ethernet signal – the Art-Net / sACN / P3 signal to the other networked fixtures in the daisy chain will not be interrupted.

Data rate

Any Ethernet switch used to relay Art-Net, sACN or P3 data to the fixture must be capable of running at 10/100 Mbps speed, as the fixture does not support Gigabit Ethernet data rates.

Control options

You can control the MAC Aura Raven XIP using DMX and/or Martin P3 protocol, and the fixture is also RDM-compatible. The fixture auto-senses the type of data that it is receiving and will respond correctly with no need for manual protocol selection.

The following options are available:

- DMX control over standard DMX cable connected to the fixture's 5-pin XLR connectors.
- DMX control using Art-Net over Ethernet cable connected to the fixture's etherCON connectors.
- DMX control using streaming ACN over Ethernet cable connected to the fixture's etherCON connectors.
- DMX control over DMX cable and P3 video data over Ethernet cable.
- P3 video data with embedded DMX commands over Ethernet cable. If you connect DMX / Art-Net / sACN to the P3 system controller, the controller can merge the DMX commands into the P3 signal and send them to the fixture over Ethernet.

The P3 Mix DMX channel lets you choose how the fixture should behave if it receives both DMX data and P3 video data. You can use the P3 video pixel data to control the intensity and/or the color of the fixture's output with real-time control.

Data rate

Any Ethernet switch used to relay Art-Net, streaming ACN or P3 data to the MAC Aura Raven XIP must be capable of running at 10/100 Mbps speed, as the fixture does not support Gigabit Ethernet data rates.

DMX

The MAC Aura Raven XIP accepts a DMX-512A data signal.

DMX setup

The DMX address, also known as the start channel, is the first channel used to receive instructions from the controller. For independent control, each fixture must be assigned its own control channels. If you give the same DMX address to two fixtures of the same type, they will behave identically. Address sharing can be useful for diagnostic purposes and symmetrical control, particularly when combined with the inverse pan and tilt options.

DMX modes

You can set the MAC Aura Raven XIP to one of six DMX operating modes: Compact, Basic, Extended, Ludicrous, Plaid and Compact Direct. See the DMX Protocols section starting on page 40 of this manual for details of the commands available and number of DMX channels used in each DMX mode.

Plaid mode uses more than 512 DMX channels, so it cannot be controlled via DMX over DMX cable. This mode is therefore only available when the fixture is controlled by Art-Net, sACN or Martin P3.

P3 creative LED and video

The MAC Aura Raven XIP accepts video data using Martin's proprietary P3 video protocol that has been a well-established standard in the industry for over 15 years. It lets you send a video signal from a media server or other video source to P3-compliant creative LED fixtures and moving heads over Ethernet cable using Martin's reliable P3 data protocol.

The intuitive graphic user interface in Martin P3 controllers lets you visualize and set up a custom installation that can contain a huge number of fixtures in any kind of physical arrangement within a few minutes. Device identification is automatic. You can arrange devices on the monitor using drag-and-drop. Latency from video input to output on fixtures is extremely low, while there is no latency between fixtures as they are fully synchronized via the P3 protocol. If you use P3 you do not need to worry about IP addresses, as P3 does not use IP addresses or IP communication.

The P3 protocol will supply both DMX data and video pixel data to fixtures over a network cable. On the MAC Aura Raven XIP you can use the video pixel data to control the intensity and/or the color of the fixture's output with real-time control using the P3 Mix DMX channel.

RDM

The MAC Aura Raven XIP is compatible with RDM (Remote Device Management), which allows remote fixture setup and management over the DMX data link. See 'Using RDM' on page 27.

Effects

This section gives details of the effects available in the MAC Aura Raven XIP. See the 'DMX protocols' section starting on page 40 for a full list of the DMX channels and values required to control the different effects.

Shutter and strobe effects

The fixture's electronic shutter effect provides instant blackout and snap open as well as regular or random strobe effects with variable speed from approximately 1 Hz to 20 Hz.

Dimming

Smooth 0-100% overall dimming is available with 16-bit control resolution. Four dimming curves are available (see 'Dimming curves' on page 14).

Color mixing

The fixture features RGBL continuous color mixing for the Beam and RGB continuous color mixing for the Aura. The Beam has color mixing with 16-bit resolution.

The way color is mixed depends on DMX mode:

- In Compact, Basic, Extended, Ludicrous and Plaid DMX modes, the fixture uses CTC + Tint + RGB color mixing. This means you can set your desired white point using the CTC and Tint channels and then mix colors on top of that using the RGB channels. The fixture calculates the balance between Red, Green, Blue and Lime LEDs to hit the desired white or color most effectively.
- In Compact Direct mode, the fixture uses raw RGBL color mixing. This means that you manually control the balance between the Red, Green, Blue and Lime LEDs to hit the desired white or color.

Virtual color wheel

Both the Beam and the Aura pixels feature a virtual color wheel with 48 color presets that use popular Lee-referenced colors.

In normal operation the virtual color wheel overrides the color mixed by the RGBL and RGB color mixing channels.

When using the fixture's FX, the virtual color wheel lets you select a background color while you use RGB color mixing channels to set the foreground color.

Zoom

Zoom control via DMX lets you vary the beam angle within this range:

- **Wide**
 - Beam angle (half-peak): 35.5°
 - Field angle (tenth-peak): 52.0°
- **Narrow**
 - Beam angle (half-peak): 6.6°
 - Field angle (tenth-peak): 9.8°

CTC

8-bit color temperature control is available on a separate channel (or in DMX modes that offer separate Beam and Aura control, on two separate channels, one for the Beam and one for the Aura). You can adjust color temperature from 2000 K to 12 850 K.

The default DMX value on this channel is 128. At this value, color temperature is 6500 K. Changing the DMX value adjusts color temperature to a calibrated level on the black body curve.

Green/Magenta shift

Green/Magenta shift, or tint control, can be adjusted from a Magenta shift (0.05 negative Duv) to Green shift (0.05 positive Duv).

The default DMX value on this channel is 128. At value 127-128, there is no green or magenta shift. Changing the DMX value moves the white point off the black body curve towards green or magenta while keeping the correlated color temperature unchanged.

FX: Pre-programmed effects macros

FX in the MAC Aura Raven XIP are pre-programmed macros that let you display impressive, complex effects with a minimum of programming. See 'FX' on page 53 for a full list of the FX available.

LED PWM frequency

In all DMX modes, it is possible to adjust the PWM frequency by +/- 2% relative to the standard frequency of 2400 Hz.

It is also possible to set the fixture's LEDs to a *High* PWM frequency of 19 200 Hz. This setting reduces the quality of low-level dimming, but it eliminates flicker when used with specific camera settings.

Pan and Tilt

The MAC Aura Raven XIP 's head can pan through a range of 540° and tilt through 250° with 16-bit control resolution available in all the fixture's DMX Modes.

See the pan/tilt orientation reference drawings at the end of this user manual for a guide to the direction of pan and tilt movement.

Rotating Beamshaper accessory

A motorized rotating Beamshaper module that mounts on the front of the head is available as an optional accessory for the MAC Aura Raven XIP. The Beamshaper accessory forms the beam into an oval shape that can be oriented from -180° to +180°.

Once the Beamshaper accessory is installed, the beamshaper effect is constantly applied. To use the fixture without the beamshaper effect applied, you will need to remove the Beamshaper accessory.

Installing and removing the Beamshaper accessory is an easy task that should take no more than a couple of minutes. Installation instructions are provided with the Beamshaper accessory. Bear in mind that the fixture needs to be powered off during installation or removal.

Warning! The Beamshaper accessory is rated IP20. Installing this accessory on the front of the fixture reduces the fixture's IP rating from IP54 to IP20. When using the Beamshaper accessory, ensure that the fixture is installed only in an environment that is suitable for this lower IP20 rating.

Fixture setup

You can adjust fixture settings using one or more of the following methods:

- The fixture's onboard control panel (see 'Control panel' on page 25)
- RDM (see 'Using RDM' on page 27)
- DMX (see 'Control/Settings DMX channel' on page 51)
- A Martin P3 System Controller
- NFC using the Companion Mobile app.

Any changes that you make to the fixture's settings are stored in memory when the fixture is powered off.

This chapter explains the settings that you can adjust.

Fixture ID

Available using: Control panel – RDM – P3 – NFC

FIXTURE ID lets you view or set a 4-digit custom ID number to help you identify the fixture. When you open this setting for the first time, the fixture displays its DMX address. It will continue to display this until you set an ID number for the fixture.

DMX control mode

Available using: Control panel – RDM – P3 – NFC

The MAC Aura Raven XIP offers six DMX modes: Compact, Basic, Extended, Ludicrous, Plaid and Compact Direct. See the 'DMX protocols' section at the end of this manual for details of the DMX control options available in the different modes and the number of DMX channels used.

Because the fixture's DMX mode affects the number of DMX channels used, it will also affect the assignment of DMX addresses to fixtures. It is therefore a good idea to set the DMX mode of all the fixtures in the installation before you set their DMX addresses.

DMX address

Available using: Control panel – RDM – P3 – NFC

The DMX address, also known as the start channel, is the first channel used to receive instructions from a DMX controller. If you have a group of fixtures and you set the first fixture's DMX address to 1, the fixture will use DMX channel 1 and the channels above it (the number of channels used will depend on the fixture's DMX mode). The channels above these are available for the next fixture.

For independent control, each fixture must be assigned its own control channels. You can give the same DMX address to two fixtures of the same type if you want them to behave identically. Giving the same DMX address to multiple fixtures can be useful for grouped control and for troubleshooting.

DMX universe

Available using: Control panel – RDM – P3 – NFC

It is possible to set the fixture's DMX universe from 1 to 63999.

Network settings

Available using: Control panel – RDM – P3 – NFC

The following Ethernet settings are available:

- IP ADDRESS lets you view the fixture's IP address or manually set a new static IP address.
- SUBNET MASK lets you view the fixture's subnet mask or manually set a new subnet mask.
- MAC ADDRESS lets you view the fixture's 12-digit MAC address.
- RESET IP SETUP lets you clear all Ethernet settings and return the fixture to automatic IP addressing, in which the fixture auto-generates its own IP address based on its MAC address.

Pan/tilt inversion

Available using: Control panel – RDM – P3 – NFC

The PAN INVERT and TILT INVERT settings let you reverse the direction of pan and tilt. This can be useful if you want to create symmetrical effects with multiple fixtures, or if you want to coordinate the movement of fixtures that are standing on the floor with fixtures that are being flown upside down in a rig.

Pan/tilt speed

Available using: Control panel – DMX – RDM – P3 – NFC

The pan/tilt speed setting has three options:

- STANDARD (the default setting) is designed to give a good compromise between speed and smoothness of pan and tilt movement.
- FAST optimizes pan and tilt movement for speed. Slow pan and tilt movement may be less smooth.
- SMOOTH optimizes pan and tilt movement for smoothness. Maximum pan and tilt movement speed is reduced.

We recommend that you do not use the FAST pan/tilt speed setting when a Beamshaper accessory is installed. Fast pan rotation with Beamshaper rotation in the opposite direction will create significant G-forces which may lead to step loss in the Beamshaper.

Effects speed

Available using: Control panel – RDM – P3 – NFC

You can optimize the zoom effect movement (and beamshaper indexing if a beamshaper accessory is installed) depending on whether you want the fastest or the smoothest action. There are four options:

- STANDARD is designed to give a good compromise between speed and smoothness of effects movement.
- FAST optimizes effects movement for speed. Slow effects movement may be less smooth.
- SMOOTH optimizes effects movement for smoothness. Maximum effects movement speed is reduced.
- FOLLOW P/T (the default setting) sets effects movement to the option that is selected for pan and tilt movement (see above).

We recommend that you do not use the FAST effects speed setting when a Beamshaper accessory is installed.

Pan and tilt limits

Available using: Control panel – DMX – RDM – P3 – NFC

The pan and tilt limit options let you define minimum and maximum limits for pan and tilt angles so that you can install fixtures close to obstacles (such as other fixtures or trusses) with no risk of collision, so that the beam will only hit a certain area of a stage or set, or so that you can avoid the fixture shining into the eyes of the audience, for example. If you set limits, the fixture's pan and tilt movement will remain in a 'safe zone' within those limits.

The STORE LOWER PAN LIMIT and STORE UPPER PAN LIMIT settings define the minimum and maximum limits for the fixture's pan range. STORE LOWER TILT LIMIT and STORE UPPER TILT LIMIT do the same thing for tilt range.

To set a limit, use the pan or tilt DMX channel to move the head to the position where you want to set the limit, then send the relevant STORE command for the amount of time required to activate it.

Once you have stored one or more pan and tilt limits, send an ENABLE PAN AND TILT LIMITS command to activate the limits. Sending a RESET PAN/TILT LIMITS command erases all the limits that have been stored.

An **LIM** message appears in the control panel display when one or more pan and tilt limits are active.

Note that when you power the fixture off, the head may move under its own weight to a position that is outside its pan and tilt limits.

Pan and tilt feedback

Available using: Control panel only

The fixture features pan/tilt position feedback sensors to ensure accurate positioning of the head.

Pan/tilt feedback is enabled by default. If you experience unexpected positioning behavior, it can be useful to disable the pan/tilt position feedback system using the SERVICE control menu.

Dimming curves

Available using: Control panel – DMX – RDM – P3 – NFC

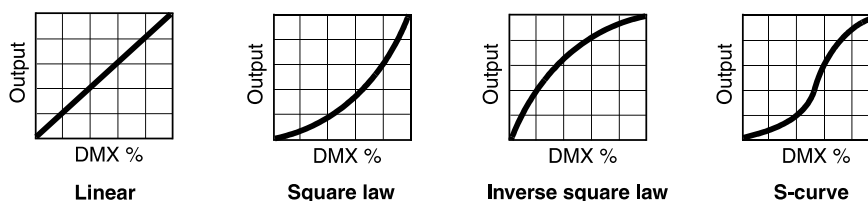

Four dimming curves are available:

- **LINEAR** – The increase in light intensity appears to be linear as DMX value is increased.
- **SQUARE LAW** (the default setting) – light intensity control is finer at low levels and coarser at high levels.
- **INVERSE SQUARE LAW** – light intensity control is coarser at low levels and finer at high levels.
- **S-CURVE** – light intensity control is finer at low levels and high levels and coarser at medium levels.

Tungsten emulation

Available using: Control panel – DMX – RDM – P3 – NFC

In tungsten emulation mode, the fixture's white light output is warmer, the warm shift is increased at lower dimming levels, and response to fast changes in intensity is slower, giving an 'afterglow' effect after dimming. This mode gives the look and feel of a fixture that uses an incandescent light bulb as its source.

Color mode

Available using: Control panel – DMX – RDM – P3 – NFC

Two color modes give options for RGB color mixing that affect color saturation and evenness between fixtures:

- **EXTENDED GAMUT** optimizes LED deployment for color saturation and gets the deepest color saturation possible from the LEDs. The white color point is calibrated and even across different fixtures, but as the fixture approaches full color saturation there can be very small differences in color rendition between different fixtures.
- **CALIBRATED COLOR** optimizes LED deployment for even color rendition between fixtures. All fixtures display identical color from white point to full color saturation, and maximum color saturation levels are limited slightly to ensure this.

Calibrated Color Mode may be useful if you notice slight differences in color performance across multiple fixtures. Note that the colors obtained through RGB color mixing in Calibrated Color Mode may differ significantly from the colors obtained in Extended Gamut Mode. Multiple fixtures in the same installation should normally all be set to either Extended Gamut or Calibrated Color Mode in order to ensure the most consistent color behavior.

Video tracking

Available using: Control panel – DMX – RDM – P3 – NFC

When VIDEO TRACKING is enabled, color fading is optimized for speed of color changes if used with a video source. The fixture does not 'smooth out' DMX input but instead snaps instantly when a DMX value changes. We recommend that you enable video tracking when displaying video.

When VIDEO TRACKING is disabled, color fading is optimized for smoothness. The fixture processes the DMX signal it receives, tracking (or smoothing out) changes in values in order to ensure smooth fading between colors and/or intensities. This signal processing takes fractions of a second and is normally invisible, but if the fixture is used to display video (using a Martin P3 System Controller, for example) the processing can interfere with video response times. We recommend that you disable video tracking during normal DMX control.

Cooling mode

Available using: Control panel – DMX – RDM – P3 – NFC

The cooling mode setting lets you decide whether to give priority to lowest cooling fan noise or maximum light output. Five settings are available:

- **REGULATED FANS** balances the fixture's noise and light output characteristics. Fans first run at low speed. If the fixture's operating temperature rises above the permitted range, fan speed is increased. If the fixture reaches maximum permitted operating temperature and full-speed fan operation is not enough to control fixture temperature, light output intensity is limited to keep the fixture within its operating temperature range.
- At the **CONSTANT FULL** setting, the fans operate at constant full speed without temperature regulation. This setting maximizes cooling and gives priority to the highest possible light output intensity. FULL fan mode can also be used as a quick way of dislodging dirt from fans. The fixture reduces light output if full fan speed is not enough to keep the fixture within its operating temperature limits.
- At the **CONSTANT MEDIUM** setting, the fans operate at constant medium speed without temperature regulation. The fixture reduces light output if medium fan speed is not enough to keep the fixture within its operating temperature limits.
- At the **CONSTANT LOW** setting, the fans operate at constant low speed without temperature regulation. The fixture reduces light output if low fan speed is not enough to keep the fixture within its operating temperature limits.
- At the **CONSTANT ULTRA LOW** setting, the fans operate at constant very low speed without temperature regulation in order to give the lowest possible noise level. The fixture reduces light output if ultra-low fan speed is not enough to keep the fixture within its operating temperature limits.

Because the MAC Aura Raven XIP adjusts the maximum possible light output intensity level as a function of fixture temperature, the choice of cooling mode will affect the maximum intensity level available. The exact level will vary depending on factors such as ambient temperature, airflow in the installation etc., but to give an approximate indication, at ambient temperature 20–25° C (68–77° F) you can expect to obtain the following intensity levels in the fixture's different cooling modes relative to the REGULATED FANS mode:

- **REGULATED FANS:** 100%
- **CONSTANT FANS ULTRA LOW:** 78%
- **CONSTANT FANS LOW:** 101%
- **CONSTANT FANS MEDIUM:** 105%
- **CONSTANT FANS FULL:** 107%

Outdoor operation and drying out function

Available using: Control panel – DMX – RDM – P3 – NFC

The fixture has features to help you manage using the fixture outdoors:

- Sending an EMPTY HEAD command moves the head to drain away any accumulated water.

- If you run a DRY OFF procedure, the fixture uses heat, fans and movement to accelerate the drying out of the outside of the fixture. Run the DRY OFF procedure before putting the fixture into a flightcase or other container for storage or transport if the fixture has been used in wet or damp conditions. Placing a wet fixture in an enclosed space can lead to corrosion and condensation.
- The SAFE PARKING function moves the fixture head to a safe position where no water or snow can build up in front of the lens and where sunlight damage is avoided.

The DMX Control/Settings channel also includes an AUTO EMPTY WATER function. When enabled, the fixture automatically moves the head to drain away water if the fixture senses that water has accumulated on the front of the head.

See also 'Outdoor status readouts' on page 22

DMX reset enable

Available using: Control panel – RDM – P3 – NFC

This setting lets you decide whether it should be possible to send a reset command to the fixture via DMX. Disabling DMX RESET ENABLE makes it impossible to reset a fixture accidentally, an action that could cause a major disruption during a show.

Display sleep

Available using: Control panel – DMX – RDM – P3 – NFC

You can set the fixture's onboard control panel display to remain permanently on, or enter sleep mode and black out after 2 minutes, 5 minutes or 10 minutes to limit distractions for the audience.

If the control panel is in sleep mode, it will light up again as soon as a button on the fixture's control panel is pressed. If ERROR DISPLAY MODE (see below) is set to NORMAL, the display will light up again if the fixture detects an error.

Display rotation (inversion)

Available using: Control panel – RDM – P3 – NFC

You can set the orientation of the control panel display to NORMAL or ROTATE 180° (display inverted to make it easier to read if you install the fixture with the head hanging vertically downwards).

Display intensity

Available using: Control panel – RDM – P3 – NFC

You can set the brightness of the control panel display from 10% to 100%.

Display contrast

Available using: Control panel – RDM – P3 – NFC

You can set the contrast of the backlit LCD control panel display from 3% to 100%. The default setting is 41%.

Error display mode

Available using: Control panel – RDM – P3 – NFC

The fixture has two options for displaying any errors detected by the self-diagnostic system:

- SILENT disables the showing of error messages and warnings in the control panel display unless the display is activated manually by keypress. The status LED still lights amber to indicate a warning and red to indicate an error.
- NORMAL enables error messages and warnings in the control panel display. If the fixture needs to report an error, the display lights up and shows the error message. The status LED lights amber to indicate a warning and red to indicate an error.

Viewing stored status (error and warning) messages

Available using: Control panel – RDM – NFC

It is possible to view a list of up to twenty status messages that the fixture has stored using either the SERVICE menu in the fixture's control panel, an RDM-compatible DMX controller or the Companion Mobile app after scanning the fixture via NFC.

Hibernation mode

Available using: Control panel – DMX – RDM – P3 – NFC

Hibernation mode sets light output intensity to zero and disables effect deployment. It brings power consumption down to around 6 W and provides an economical option if you want to keep power applied to the fixture when it is not in use. In an architectural or theatre setting, for example, you can set up a cue at the controller that switches the fixture to hibernation mode during periods when the fixture is not active.

When you bring the fixture out of hibernation mode it performs a full reset, so be prepared for it to move.

Standalone operation

Available using: Control panel – DMX – RDM with Martin Companion – P3

In standalone operation, the fixture can show one or more scenes (a 'scene' is a programmed 'look' or combination of effects) with no controller connected.

Single-scene standalone

Using the fixture's control panel, the DMX Control/Settings channel or P3 you can set up single-scene standalone operation as follows:

1. Using either DMX or manual control in the fixture's control panel, set the fixture to display the scene that you want to store as the standalone scene.
2. Send a *Record Standalone Scene* command using the control panel, the Control/Settings DMX channel or P3 to store that scene into the fixture's memory.
3. Send an *Enable Standalone* command using the fixture's control panel, the Control/Settings DMX channel or P3. The fixture will now show that scene at all times when it is powered on and not receiving a control signal.

If the fixture receives a DMX control signal during standalone scene playback, it will immediately stop showing its saved scene. If fixture power is cycled off and on again or if the fixture is reset, it will again show its saved scene.

4. If you disable standalone operation, the fixture simply blacks out if it stops receiving a control signal. However, disabling standalone operation does not delete the saved scene from memory: the scene will still be available if you enable standalone operation again.

Multi-scene standalone

Using RDM via the Martin Companion Desktop application you can set up a multi-scene standalone show. You can program up 20 scenes with individual hold (scene duration) and fade (scene change) times. You can synchronize the standalone show in multiple fixtures. Martin Companion features an intuitive interface, so we only give brief details of standalone programming below.

To program a standalone show using Martin Companion:

1. Connect a PC running the Martin Companion application to the data link. If fixtures are connected via a traditional DMX512 link, you can connect the PC to the link using the Martin Companion USB-to-DMX hardware interface that is available from Martin suppliers.
2. Apply power to the fixtures on the link that you want to program.
3. Navigate to the Standalone screen in Martin Companion and wait for all fixtures to be discovered automatically. Then select which fixtures you want to program for standalone operation using the checkboxes in front of them.

You can now:

- click on **Create** to create a new Standalone show for those fixtures,
- or click on **Edit** to modify the Standalone show already present inside the selected fixtures,
- or click on **Clear Fixture(s)** to delete any previous Standalone show from the selected fixtures.

You can also load a previously created show from a file if you click on **Load Show**.

4. The rest of the standalone programming process is fairly intuitive in Martin Companion's interface.

Note that not all fixtures in a standalone show have to show the same scenes – it is possible to create a different scene for each fixture. Martin Companion automatically selects one fixture to act as the host in synchronized standalone operation (see below).

If you enable standalone operation, fixtures will run their standalone show at all times when they are powered on and not receiving a control signal.

If fixtures receive a control signal during standalone scene playback, they will immediately stop showing their standalone show. If fixture power is cycled off and on again or if the fixture is reset, it will again show its saved standalone show.

If you disable standalone operation, fixtures simply black out if they stop receiving a control signal. However, disabling standalone operation does not delete the saved show from memory: the show will still be available if you enable standalone operation again.

Synchronized standalone operation

All fixtures programmed together for standalone operation will synchronize the playback of their standalone scenes. Fixtures need to be connected to each other on a data link for synchronization to work, but they do not need to be connected to a DMX / P3 / Art-Net / sACN controller. Fixtures that are synchronized will switch to the same scene number with the same duration and fade time, but different fixtures can have a different lighting effect programmed into them for any one scene number.

Note that Martin Companion automatically assigns one fixture as the standalone *host*, and all the others as *clients*. The host fixture only tells the client fixtures to “go to scene X with fade time Y”. The lighting effect that each fixture uses in a specific scene is stored inside each fixture individually. Again, not all fixtures have to show the same lighting effect in each scene. Only the duration and fade times are synchronized.

Storing and recalling custom settings

Available using: Control panel only

The custom configuration function CUSTOM 1 - CUSTOM 3 allows you to save and recall up to three sets of fixture settings. These include all the settings in the PERSONALITY menu as well as the fixture's DMX address, DMX control mode and user-settable 4-digit fixture ID.

Resetting to factory defaults

Available using: Control panel – RDM – P3 – NFC

It is possible to return the fixture to its factory default settings, erasing any custom settings that you have configured.

Note that restoring factory default settings does not affect the fixture's calibration settings.

Fan cleaning

Available using Control panel – RDM – P3 – NFC

Fan cleaning mode sets the cooling fans to spin at maximum speed for a short period in order to dislodge dust, confetti, etc. from fan blades. The fan cleaning sequence is not enough to clean fan blades completely, but it removes large particles so it can be effective at removing the worst dirt between services while a fixture is still in the rig.

DMX LIVE signal monitoring

Available using: Control panel only

The DMX LIVE → SOURCE command lets you view the current control data source: No data being received / DMX / Art-Net / sACN / P3 / wireless Universal Connect Module,

You can view the DMX values 0 – 255 that are currently being received on each of the fixture's DMX channels in the control panel's DMX LIVE menu. This can be useful for troubleshooting purposes.

- RATE displays the DMX refresh rate in packets per second. Values lower than 10 or higher than 44 may result in erratic performance, especially when using tracking control.
- QUALITY displays the quality of the received DMX data as a percentage of usable packets from the data received. Values much below 100 indicate interference, poor connections, or other problems with the serial data link that are the most common cause of control problems.
- START CODE displays the DMX start code. Packets with a start code other than 0 may cause irregular performance.

Manual control

Available using: Control panel only

You can control all the fixture's effects (including pan and tilt) manually using the fixture's control panel without the need for a DMX signal.

To manually control the fixture:

1. Scroll to the MANUAL CONTROL menu and then use the UP and DOWN buttons to scroll to the effect that you want to control. Press ENTER.
2. Use the UP and DOWN buttons to scroll to the DMX value from 000 to 255 (or 000 to 65535 where 16-bit control is available) that you want to send to that effect. Press ENTER to confirm and send that value.
3. To return to the list of effects, press MENU.
4. If you want to manually control other effects together with the first effect, repeat steps 1. and 2. and 3. above for the other effects.

The fixture will continue to show the effects that you have set manually until you set new manual control values for the effects.

Exiting the MANUAL CONTROL menu by pressing the MENU button stops all the effects immediately.

Fixture test sequences

Available using: Control panel – RDM – P3 – NFC

You can run an automatic sequence to test all the fixture's effects or manually test individual effects.

Automatic effects test

When using the fixture's control panel, you can test all the effects as follows:

1. Scroll to TEST → TEST ALL and press ENTER to confirm.
2. Use the DOWN and UP buttons to scroll through all the fixture's effects.
3. When you have reached the effect that you want to test, press ENTER to confirm your selection. The fixture will now run an automatic test of that effect.
4. Press MENU to exit the test and return to the list of effects.
5. To stop the test and return to the previous level of the menu structure, press MENU.

LED tests

When using the fixture's control panel, you can test LEDs as follows.

To test the fixture's LEDs:

1. Scroll to TEST → TEST LEDs and press ENTER.
2. Use the DOWN and UP buttons to scroll through the fixture's LED groups and color wheel effects.

3. When you have reached the effect that you want to test, press ENTER to confirm your selection. The fixture will now run an automatic test of that effect.
4. Press MENU to exit the test and return to the list of effects.
5. To stop the test and return to the previous level of the menu structure, press MENU.

Testing the Zoom effect

To test the fixture's Zoom functionality:

1. Scroll to TEST EFFECTS → TEST ZOOM and press ENTER. The fixture will now run an automatic test of the Zoom effect.
2. Press MENU to exit the test.
3. To stop the test and return to the previous level of the menu structure, press MENU.

Testing Pan and Tilt

To manually test pan and tilt movement:

1. Select TEST → TEST PAN/TILT and then either PAN or TILT.
2. Press ENTER. The fixture will now run an automatic test of pan or tilt functionality.
3. To stop the test and return to the previous level of the menu structure, press MENU.

Resetting the fixture

Available using: DMX – RDM – P3 – NFC

You can reset the entire fixture, returning it to its state when first powered on. Be prepared for the head to move through its full range of pan and tilt movement while pan and tilt resets. The reset process takes several seconds.

Displaying test patterns

Available using: P3

It is possible to display test patterns, adjust test pattern intensity and override any DMX signal that the fixture is receiving using a Martin P3 System Controller.

'Identify device' signal

Available using: RDM – P3

The **Identify Device** command makes the fixture flash a signal and move the head so that you can identify it in the rig.

Fixture information readouts

Power on time

Available using: Control panel – RDM – P3 – NFC

The fixture has two counters that register the number of hours the fixture has been powered on:

- One counter registers the number of hours since manufacture and is not user-resettable.
- One counter can be reset by the user to keep track of hours since last service, for example.

Power on cycles

Available using: Control panel – RDM – P3 – NFC

As with the power on hours counter, the fixture has a non-resettable and a resettable counter that register the number of times power has been cycled off and on.

LED operating time

Available using: Control panel – RDM – P3 – NFC

The fixture has non-resettable and a resettable counters that register the number of hours Beam LEDs and Aura LEDs have been active.

Firmware version

Available using: Control panel – RDM – P3 – NFC

The FIRMWARE command lets you see which firmware (fixture software) version is installed in the fixture.

Instructions for updating the firmware are given in the Service and Maintenance chapter later in this User Manual.

RDM unique ID number

Available using: Control panel – RDM – P3 – NFC

The fixture receives a unique 12-digit RDM ID number at the factory to allow RDM devices to identify it. You can view this number, but it is of course non-resettable.

Manufacturer's serial number

Available using: RDM – P3 – NFC

The fixture receives a unique serial number at the factory. You can view this number, but it is of course non-resettable.

Temperature readouts

Available using: Control panel – RDM – P3 – NFC

You can consult readings from all of the fixture's temperature sensors. When using the fixture's control menus, scroll through the list of sensors and press ENTER to view a readout. Press MENU to return to the list of sensors.

Temperatures are indicated in degrees Celsius.

Fan speeds

Available using: Control panel – RDM – NFC

The fixture is capable of telling you the speed in RPM of each of its cooling fans. When using the fixture's control menus, scroll through the list of cooling fans and press ENTER to view a fan speed readout. Press MENU to return to the list of cooling fans.

Outdoor status readouts

Available using: Control panel

The SERVICE menu in the control panel contains an OUTDOOR submenu with the following readouts:

- WET STATE is a readout from an external sensor on the fixture's base that indicates whether the fixture is wet or dry.
- WET CURRENT indicates how long in minutes the fixture has been wet, based on the readout from the above sensor.
- WET LIFETIME indicates how long in minutes the fixture has been wet since manufacture, based on the readouts from the above sensor.

Base orientation

Available using: Control panel

The OUTDOOR submenu in the SERVICE menu also lets you view information from an internal system that detects the orientation of the fixture's base at power on. The readouts from this system can be a useful addition to a visual check and can help service technicians check correct system functionality.

Calibration

Available using: Control panel – DMX

The SERVICE → CALIBRATION control menu and the Control/Settings DMX channel let you define custom offsets in the fixture software to adjust the positions of pan, tilt and effects relative to the DMX values the fixture receives. Creating calibration offsets allows you to fine-tune fixtures and achieve uniform behavior in multiple fixtures.

Martin fixtures are adjusted and calibrated at the factory, and further calibration should only be necessary if fixtures have been subjected to abnormal shocks during transport or if normal wear and tear has affected alignment after an extended period of use. You can also use calibration to fine-tune fixtures for a particular location or application.

We recommend using one of the following two procedures to adjust calibration settings. When you have calibrated effects using one of these two procedures, the fixture will remember any new calibration values that you have set, and the new positions will not be affected by powering the fixture off and on.

Calibration procedure

First, aim a reference fixture and the fixtures that you want to calibrate at a flat surface. You can calibrate fixtures one at a time or line up multiple fixtures in a row.

Apply power and set pan, tilt and effects to the same DMX values.

Calibration using the fixture's control panel

To calibrate effects positions using control panel, for each fixture that you want to calibrate:

1. Open the SERVICE → CALIBRATION menu.
2. Scroll through the effects until you reach the effect that you want to calibrate. Press ENTER to select that effect.
3. Adjust calibration by scrolling through the calibration values while comparing the light output with the reference fixture (the range of calibration values available differs for different effects).
4. When you are happy with a calibration value, press ENTER to confirm and then press MENU to return to the list of effects.
5. Continue scrolling through the effects, repeating the above process to calibrate individual effects.
6. When you have finished calibrating the last effect, press and hold MENU to exit.

Calibration using the Control/Settings DMX channel

To calibrate effects positions using DMX, for each fixture that you want to calibrate:

1. Set the first effect that you want to calibrate to a specific value via DMX (for example, set all the fixtures in a group to the same DMX value in the middle of the range on the zoom channel).
2. Select 'Enable calibration' on the Control/Settings DMX channel and hold for 5 seconds to activate.
3. The fixture now registers the current states of all effects and holds them there. To select an effect to adjust, you must first release it from its hold position by changing the value on its DMX channel by +/- 10%. The effect then returns to its hold position. The effect's DMX channel now represents the full calibration range. The range can vary but is typically +/- 5-10%. In this case you can adjust the effect's position using that effect's DMX channel (8- or 16-bit) as follows:
 - DMX value 0 = -5%
 - DMX value 127/32767 = 0%
 - DMX value 255/65535 = +5%.
4. Adjust the effect until it is in the required position (for example, adjust the zoom angle on each fixture in the group until the angle on all fixtures is identical – this is the position that you will obtain when you send DMX value 200).
5. Send a 'Store XXX calibration' command on the Control/Settings channel for each effect that you adjust and hold that command for 5 seconds to activate. The new calibration offset is now stored in memory.
6. When you have finished adjusting calibration offsets, send value 0 on the Control/Settings channel and hold for 5 seconds to exit the DMX calibration procedure and return to normal DMX control.

Loading factory default calibration values

Available using: Control panel – DMX

The fixture keeps the original factory-set calibration values in memory even if you have set custom calibration values using one of the procedures outlined above. You can erase any custom calibration values that you have defined and reload the default factory calibration values by applying a SERVICE → CALIBRATION → LOAD DEFAULTS → LOAD command.

Overwriting factory default calibration values

Available using: Control panel only

It is possible to overwrite the factory-set calibration values and replace them with the currently defined calibration values, but take care when doing this. Please contact Martin Service if you have any questions about making this change.

Important! Overwriting factory default calibration values with custom values is permanent. If you have set a custom value and applied a CALIBRATION → LOAD DEFAULTS → SAVE command, you will not be able to recover the original factory default value.

To overwrite the factory default calibration values:

1. Set new calibration values for the effects that you want to recalibrate using one of the two procedures outlined above.
2. Apply a SERVICE → CALIBRATION → SAVE DEFAULTS → SAVE command. Important! This command will permanently overwrite the factory default calibration settings.

Adjustment menu (Martin Global Service only)

Available using: Control panel only.

Important! The SERVICE → ADJUST menu contains procedures that are for use during mechanical adjustment by Martin Global Service or authorized Martin service partners only. Do not enter the ADJUST menu without service documentation from Martin, or you may cause damage to the fixture that is not covered by the product warranty.

Pan/tilt auto-calibration

The control panel SERVICE → ADJUST menu contains a command that starts a pan and tilt auto-calibration sequence. Pan and tilt move through their full movement range during auto-calibration. Make sure that the fixture is secure and that there is space around the head for full pan and tilt movement before you start this sequence.

Service log

Available using: Control panel

The SERVICE LOG → EXPORT command in the control panel's SERVICE menu lets you take a snapshot of all the fixture's settings and all the data stored in memory to a USB flash memory drive inserted in the USB port located behind the cover to the right of the control panel. The settings and data include such information as current status messages and a status message history, rain sensor data, DMX address, DMX universe, IP address and MAC address, current values for all the fixture's counters, current status of all the fixture's settings etc.

The SERVICE LOG → CLEAR command lets you delete all stored status messages permanently from the fixture's memory.

Control panel

This section explains how to use the fixture's onboard control panel and control menus. You can find a complete map of the control menu structure in 'Control menus' on page 33.

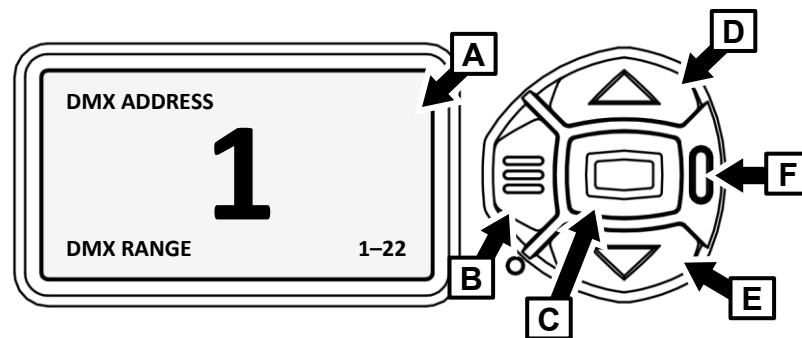

- | | |
|----------------------------------|------------------------|
| A – Control panel display | D – Up button |
| B – Menu button | E – Down button |
| C – Enter button | F – Status LED |

When the fixture is powered on, it first boots and resets, then it displays its DMX address (or its fixture ID number, if one has been set) and any status messages in the display A.

The display can be set to automatically rotate to match standing or hanging fixture orientation in the PERSONALITY → DISPLAY menu or the Shortcuts menu (see “Shortcuts” on page 26).

Using the control panel

- Press the MENU button **B** or Enter button **C** to access the menus.
- Use the UP and DOWN buttons **D** and **E** to scroll up and down menus.
- Press the ENTER button **C** to enter a menu or make a selection.
- The currently selected menu item is indicated by a star: ✱
- Press the MENU button **B** to step backwards through the menus.

Status LED

The LED **F** next to the control buttons indicates fixture status by showing a color and DMX status by flashing or lighting constantly:

- GREEN: All parameters normal.
- AMBER: Warning (service interval exceeded, for example).
 - If ERROR MODE is set to Normal, the warning message will be shown in the display. If ERROR MODE is set to Silent, the display must be activated by pressing the Enter button **C** to display the warning message.
- RED: Error detected.
 - If ERROR MODE is set to NORMAL, the error message will be shown in the display.
 - If ERROR MODE is set to SILENT, display the error message by entering the menus and going to SERVICE → ERROR LIST.
- FLASHING: No DMX signal detected.
- CONSTANT: Valid DMX signal detected.

The status LED remains active even if the display enters sleep mode.

Battery power

Warning! The fixture's lithium battery is not rechargeable. Do not try to recharge it. If the battery is discharged, obtain a replacement from your Martin supplier.

The MAC Aura Raven XIP contains a CR123A 3-volt lithium battery behind a cover next to the control panel. The battery gives access to the most important functions in the control panel when the fixture is not connected to AC power. The following functions are available on battery power:

- DMX address
- DMX Mode
- Fixture ID
- Personality settings
- Default fixture settings
- Information (Power On Hours and Power Cycles counters, Software version)
- Error list.

To activate the display when the fixture is not connected to power, press the MENU button **B**. Press again to enter the menus. The display extinguishes after 10 seconds with no user input and the control panel is de-activated after 1 minute with no user input. Press the MENU button **B** again to re-activate.

Shortcuts

If you hold the MENU button **B** pressed in for 2 - 3 seconds, a shortcut menu with the most important commands appears. Select a command with the UP and DOWN buttons and press the ENTER button **C** to activate, or press the MENU button **B** again to cancel.

- RESET ALL resets the whole fixture.
- ROTATE DISPLAY rotates the fixture's control panel display 180°.
- CLEAR PAN/TILT LIMITS clears all currently set pan and tilt limits.
- SET PAN/TILT LIMITS re-enables any pan and tilt limits stored in the fixture that have been disabled.
- SERVICE LOG exports a copy of all the fixture's stored data and settings to any USB flash drive that is inserted in the USB port behind the battery cover.

Settings stored permanently

The following settings are stored permanently in the fixture memory and are not affected by powering the fixture off and on or by updating the fixture software:

- DMX address
- DMX universe
- DMX Mode
- Fixture ID
- Personality settings (pan/tilt, cooling, dimming curve, DMX reset possible, effect shortcuts, display settings, error mode, etc.)
- Resettable and non-resettable counters
- Service settings (adjustment, calibration)

These settings can be returned to factory defaults using the control menus or via DMX.

Activating service mode

Holding the MENU and ENTER buttons both pressed in while powering the fixture on puts the fixture into service mode, in which pan and tilt are disabled and a SERV warning appears in the display.

Service mode removes the risk of unexpected head movement during service adjustments.

To take the fixture out of SERVICE mode, power the fixture off, then reapply power and allow the fixture to start normally.

Using RDM

RDM can be used to adjust many fixture settings and view readouts. This chapter gives information on using the Martin Companion Windows software application to set up and manage the MAC Aura Raven XIP via RDM. While we recommend the use of Martin Companion, most of the commonly available RDM controllers also support the MAC Aura Raven XIP. Check with the controller manufacturer if you cannot find the Martin MAC Aura Raven XIP in the list of supported fixtures. The exact procedures and command names used by different RDM controllers vary.

Setting up single or multiple fixtures

You can set behavior in one fixture by sending a unicast RDM command to that one fixture only, or you can set behavior in all the fixtures on the data link by sending a broadcast RDM command to all the fixtures.

Martin Companion® and RDM

To set up MAC Aura Raven XIP fixtures via RDM, we recommend using the **Martin Companion Cable** PC-to-DMX interface that is available as an accessory from Martin suppliers. This tool plugs into the USB port of a Windows PC and connects to Martin fixtures over the DMX data link via a 5-pin XLR connector. The Martin Companion Cable is designed to work together with the **Martin Companion software suite** for Windows PCs. This software can be downloaded free of charge from the Martin website at www.martin.com. Martin Companion will always offer the latest MAC Aura Raven XIP features and firmware when your PC is connected to the Internet.

Instructions for connecting the Martin Companion Cable are supplied with the tool and can also be downloaded from the Martin website.

Martin Companion offers the following features:

- Simple PC-based user interface
- Update of fixture firmware
- RDM configuration and DMX addressing
- Standalone show programming with automatic start when fixtures are powered on.

RDM functions

A full list of the RDM functions that MAC Aura Raven XIP fixtures support is given at the end of this chapter. We refer to these functions using the more specific term 'PIDs' ('Parameter IDs').

Fixture discovery

Before you can communicate with fixtures using RDM, you must send a scan command (fixture discovery command) to all the devices on the data link so that the RDM controller can identify them. It does this by retrieving each device's factory-set unique identifier (UID). This process can take some time, depending on the number of devices on the link.

To identify the fixtures on the link:

1. Check that the fixtures are correctly connected to the RDM controller on the data link and that power is applied to all fixtures.
2. Send a discovery command via RDM (Martin Companion does this automatically as soon as the cable is connected).
3. Give the controller time to identify the devices on the link and prepare for communication with the devices.

Supported parameters

MAC Aura Raven XIP fixtures can communicate their supported control parameters to the RDM controller and give brief information on each parameter.

Example: setting a DMX address

You can set the DMX address of a fixture (or fixtures) on the data link via RDM. An example procedure from Martin Companion v. 2.0 might look like this, but the procedure will vary depending on which RDM controller you use:

Check that fixtures are powered on a connected to data over the DMX/RDM link.

Connect the Martin Companion Cable to your computer and to the DMX/RDM link.

Start the Martin Companion application.

Navigate to the **RDM** view in Martin Companion.

Wait until RDM Discovery has completed. This happens automatically, you just need to wait for the Discovery icon top right to stop blinking.

Navigate to the **Patch** tab and check the **Mode** and **Address** columns.

Update the values in those columns to change the DMX mode and/or DMX start address for the selected fixtures.

Status messages

The MAC Aura Raven XIP features a self-diagnostic system that detects any issues concerning correct operation or safety (temperature that exceeds safe level, for example) and communicates the issues as status messages or warnings. These messages can be useful in connection with service and maintenance. Error messages appear in the fixture's control panel display, but you can also call them up via RDM.

It is possible to:

- Call up a list of any status messages that the fixture has stored in memory.
- View information on the messages.
- Clear the stored list of status messages.

RDM functions

MAC Aura Raven XIP fixtures support the following RDM PIDs:

PID	Name	Description	GET	SET
Device discovery				
0x0001	DISC_UNIQUE_BRANCH	Fixture discovery	N/A	N/A
0x0002	DISC_MUTE	Fixture discovery	N/A	N/A
0x0003	DISC_UN_MUTE	Fixture discovery	N/A	N/A
Device information				
0x0060	DEVICE_INFO	Get basic fixture info	✓	
0x0080	DEVICE_MODEL_DESCRIPTION	Product name	✓	
0x0081	MANUFACTURER_LABEL	Manufacturer name	✓	
0x0082	DEVICE_LABEL	Info label (user-settable)	✓	✓
0x8003	FIXTURE_ID	Fixture number (user-settable)	✓	✓
0x8700	SERIAL_NUMBER	Fixture serial number	✓	
0x00C0	SOFTWARE_VERSION_LABEL	Firmware version	✓	
0x0200	SENSOR_DEFINITION	Sensor description	✓	
0x0201	SENSOR_VALUE	Sensor value	✓	✓

PID	Name	Description	GET	SET
0x0400	DEVICE_HOURS	Fixture hours counter (resettable)	✓	✓
0x870A	DEVICE_HOURS_TOTAL	Fixture hours counter (non-resettable)	✓	
0x0401	LAMP/LED_HOURS	Fixture LED hours counter (resettable)	✓	✓
0x870B	LAMP/LED_HOURS_TOTAL	Fixture LED hours counter (non-resettable)	✓	
0x0405	DEVICE_POWER_CYCLES	Fixture power cycles counter (resettable)	✓	✓
0x870C	DEVICE_POWER_CYCLES_TOTAL	Fixture power cycles counter (non-resettable)	✓	
DMX setup				
0x00E0	DMX_PERSONALITY	DMX mode	✓	✓
0x00E1	DMX_PERSONALITY_DESCRIPTION	DMX mode details	✓	
0x00F0	DMX_START_ADDRESS	DMX start address	✓	✓
0x0121	SLOT_DESCRIPTION	DMX channel details	✓	
Ethernet setup				
0x0700	LIST_INTERFACES	List Ethernet ports	✓	
0x0701	INTERFACE_LABEL	Name of Ethernet port	✓	
0x0702	INTERFACE_HARDWARE_ADDRESS_TYPE1	MAC address of Ethernet Port	✓	
0x0703	IPV4_DHCP_MODE	Enable DHCP client	✓	
0x0705	IPV4_CURRENT_ADDRESS	Get current IP address	✓	
0x0706	IPV4_STATIC_ADDRESS	Set static IP address	✓	✓
0x0709	INTERFACE_APPLY_CONFIGURATION	Apply Ethernet configuration		✓
0x0903	ENDPOINT_TO_UNIVERSE	Set Art-Net/sACN universe	✓	✓
Device management				
0x0050	SUPPORTED_PARAMETERS	Parameter discovery	✓	
0x0051	PARAMETER_DESCRIPTION	Parameter discovery	✓	
0x0090	FACTORY_DEFAULTS	Reset to factory defaults	✓	✓
0x1000	IDENTIFY_DEVICE	Identify fixture in rig	✓	✓
0x1001	RESET_DEVICE	Reset fixture		✓
0x1020	PERFORM_SELFTEST	Run self-test	✓	✓
0x1021	SELF_TEST_DESCRIPTION	Self-test description	✓	
0x0500	DISPLAY_INVERT	Flip display	✓	✓
0x0501	DISPLAY_LEVEL	Set display intensity	✓	✓

PID	Name	Description	GET	SET
0x0600	PAN_INVERT	Invert pan	✓	✓
0x0601	TILT_INVERT	Invert tilt	✓	✓
0x8001	DMX_RESET	Enable fixture resettable via DMX	✓	✓
0x8301	EFFECT_SPEED	Set effects speed	✓	✓
0x8308	DISPLAY_ERRORS_ENABLE	Show errors in display	✓	✓
0x8310	DIMMER_CURVE	Set dimmer curve	✓	✓
0x8004	COLOR_MODE	Set color mode	✓	✓
0x8325	VIDEO_TRACKING	Set video tracking	✓	✓
0x8312	DISPLAY_AUTO_OFF	Enable onboard display auto off	✓	✓
0x8326	DISPLAY_CONTRAST	Set onboard display contrast	✓	✓
0x8329	HIBERNATION_MODE	Enable hibernation mode	✓	✓
0x832A	TUNGSTEN_MODE	Enable tungsten mode	✓	✓
0x8400	PAN_TILT_SPEED	Set P/T speed	✓	✓
0x8402	PAN_TILT_LIMITATION_ENABLE	Enable P/T limits	✓	✓
0x8403	PAN_LIMITATION_MINIMUM	Pan minimum limit	✓	✓
0x8404	PAN_LIMITATION_MAXIMUM	Pan maximum limit	✓	✓
0x8405	TILT_LIMITATION_MINIMUM	Tilt minimum limit	✓	✓
0x8406	TILT_LIMITATION_MAXIMUM	Tilt maximum limit	✓	✓
0x8409	PAN_TILT_LIMITATION_RESET	Reset P/T limits		✓
0x8603	FAN_CLEAN	Activate fan cleaning mode (high speed fan operation)	✓	✓
0x8604	FAN_MODE	Cooling fan mode	✓	✓
0x8333	AURA_IN_COMPACT_MODE	Aura ON/OFF in Compact and Compact Direct DMX modes	✓	✓
0x8336	AUTO_EMPTY_WATER	Enable/Disable Auto Empty Water function	✓	✓
0x8337	OUTDOOR_ACTIONS	Empty, Dry Off, Safe Parking	✓	✓
UCM (Universal Connect Module – when installed in UCM port)				
0x8010	DMX_UCM_SHOW_ID	Show UCM wireless ID	✓	✓
0x8011	DMX_UCM_SHOW_KEY	Show UCM wireless PIN code	✓	✓
0x8013	DMX_UCM_RF_OUTPUT_POWER	UCM wireless transmission power	✓	✓

PID	Name	Description	GET	SET
0x8014	DMX_UCM_ANTENNA_TYPE	UCM antenna	✓	✓
0x8017	DMX_UCM_CONNECTION_STATE	Get UCM connection status	✓	
0x8018	DMX_UCM_MODULE_MODEL	Get UCM model	✓	
0x8019	DMX_UCM_MODULE_MANUFACTURE	Get UCM manufacturer	✓	
0x801A	DMX_UCM_MODULE_FIRMWARE	Get UCM firmware version	✓	
Standalone control via Martin Companion				
0x1030	CAPTURE_PRESET	Capture current 'look' and store as standalone scene		✓
0x1031	PRESET_PLAYBACK	Play back any of the stored presets	✓	✓
0x8220	MANUAL_MODE_OVERRIDE	Override DMX control with values sent via RDM	✓	✓
0x810B	PRESET_PLAYBACK_LIMIT	Sets total number of scenes in standalone mode	✓	✓
0x8101	SYNCHRONIZED	Enables synchronization in standalone mode and determines which fixture is synchronization host	✓	✓
0x810C	OFFLINE_MODE	Behavior when fixture is not receiving DMX	✓	✓
Status messages				
0x0020	QUEUED_MESSAGE	Get queued messages	✓	
0x0030	STATUS_MESSAGES	Get status/error information	✓	
0x0031	STATUS_ID_DESCRIPTION	Status/error description	✓	
0x0032	CLEAR_STATUS_ID	Clear status/error queue		✓

Using NFC

The MAC Aura Raven XIP has an NFC interface which lets you configure and read out information from the fixture using an NFC-capable cellphone with the Martin Companion app (available for Android and iOS) installed.

You can carry out the following actions via the NFC interface using the Martin Companion app:

- Adjust all the settings that are available in the fixture's onboard control menus (set DMX mode, set DMX address, select dimmer curve, select fan mode etc.)
- Monitor the fixture (read out fixture sensor data, error codes, usage data, serial numbers, firmware version etc.)
- Trigger quick actions on the fixture (reset to factory defaults, reset pan/tilt limits, run a self-test etc.)

To use the NFC interface:

1. Download the Martin Companion app to your cellphone from the Apple App Store or Google Play Store.
2. Check that NFC is enabled on the cellphone.
3. Hold the cellphone with its NFC antenna directly in front of the fixture display as shown in the photo on the right. The fixture's NFC antenna is located directly behind the control panel display.

The location of the cellphone NFC antenna is different from phone to phone. Please refer to your cellphone manual if you are not sure about the placement of the NFC antenna.







The fixture's NFC interface is also available when the fixture is powered off, even if the fixture's internal battery is discharged or missing.

Control menus

The following commands are available in the fixture's control panel. Note that commands can also be available via RDM, via DMX on the Control/Settings channel, via P3 using a Martin P3 System Controller or via NFC.



Default settings are given in **bold print**.

Menus marked with a battery icon  below are available when the fixture is not connected to power.

Menu level 1	Menu level 2	Menu level 3	Notes
DMX SETUP 			
DMX ADDRESS	1 - XXX		Set DMX address (default address = 1)
CONTROL MODE	COMPACT		Set DMX control mode
	BASIC		
	EXTENDED		
	LUDICROUS		
	PLAID		
	COMPACT DIRECT		
DMX UNIVERSE	1 - 63999		Set DMX universe (default = 1).
WIRELESS	NO MODULE ATTACHED (if no module is installed)		
	Module information – the content of this menu depends on the manufacturer and model of the UCM (Universal Connect Module) that was plugged into the fixture. See that module's documentation for details.		
ETHERNET SETUP 			
IP ADDRESS	XXX.XXX.XXX.XXX		Display fixture's static IP address
	PART 1 MSB		Set far left block (most significant byte) of IP address
	PART 2		Set middle left block of IP address
	PART 3		Set middle right block of IP address
	PART 4 LSB		Set far right block (least significant byte) of IP address
SUBNET MASK	XXX.XXX.XXX.XXX		Display fixture's subnet mask
	EDIT SUBNET MASK	XXX.XXX.XXX.XXX	Set subnet mask with 1-bit increments from the left
MAC ADDRESS	XX:XX:XX:XX:XX:XX		Display fixture's MAC address
RESET IP SETUP	RESET	ARE YOU SURE? →YES/NO	Reset static IP address and subnet mask to factory default values – fixture auto-generates its own IP address based on its MAC address
FIXTURE ID 			
0 - 9999			User-settable 4-digit fixture ID number (default = 0)

PERSONALITY 				
PAN/TILT	PAN INVERT	ON/OFF	Inverse DMX pan control: right → left	
	TILT INVERT	ON/OFF	Inverse DMX tilt control: down → up	
	LIMIT PAN/TILT	LIMIT ENABLE	ON/OFF	Enable limits for pan and tilt
		PAN MIN → degrees		Set minimum pan angle limit
		PAN MAX → degrees		Set maximum pan angle limit
		TILT MIN → degrees		Set minimum tilt angle limit
		TILT MAX → degrees		Set maximum tilt angle limit
RESET PAN / TILT LIMITS		Confirm with: ARE YOU SURE? YES/NO Returns fixture to default pan/tilt limits.		
SPEED	PAN/TILT	FAST	Adjust speed of pan and tilt movement	
		SMOOTH		
		STANDARD		
	EFFECT	FAST	Adjust speed of effects movement	
		SMOOTH		
		STANDARD		
FOLLOW P/T		Effects speed follows pan/tilt speed setting		
DIMMER CURVE	S-CURVE		S-curve (fixture emulates incandescent lamp voltage linear RMS dimming curve)	
	INV SQ LAW		Inverse square law dimming curve	
	SQUARE LAW		Square law dimming curve	
	LINEAR		Optically linear dimming curve	
TUNGSTEN EMULATOR	ON		Color temperature and dimming characteristics emulate incandescent tungsten lamp behavior	
	OFF			
COLOR MODE	CALIBRATED COLOR		Color mixing optimized for even color rendition across multiple fixtures	
	EXTENDED GAMUT		Color mixing optimized for saturation	
VIDEO TRACKING	ENABLED		Color fading optimized for speed of color changes	
	DISABLED		Color fading optimized for smoothness	
DMX RESET	ON		Fixture can be reset via DMX	
	OFF		Fixture cannot be reset via DMX	

COOLING MODE	CONSTANT FAN FULL		Fans optimized for maximum light intensity, fans run at full speed, light intensity reduced if necessary to keep fixture within temperature limits
	CONSTANT FAN MEDIUM		Fans run at medium speed, light intensity reduced if necessary to keep fixture within temperature limits
	CONSTANT FAN LOW		Fans run at low speed, light intensity reduced if necessary to keep fixture within temperature limits
	CONSTANT FAN ULOW		Fans optimized for lowest noise, fans run at ultra-low speed, light intensity reduced if necessary to keep fixture within temperature limits
	REGULATE FANS		Compromise between light intensity and quietness, fan speed temperature-regulated, light intensity only reduced if fans reach full speed and further action necessary to keep fixture within temperature limits
DISPLAY	DISPLAY SLEEP	10 MINUTES	Control panel display goes into sleep mode 10 minutes after last key press
		5 MINUTES	Control panel display goes into sleep mode 5 minutes after last key press
		2 MINUTES	Control panel display goes into sleep mode 2 minutes after last key press
		ON	Control panel permanently on
	DISPLAY INTENSITY	10 ... 100	Set control panel display intensity in % (default = 100%)
	DISPLAY ROTATION	ROTATE 180	Control panel display inverted
		NORMAL	Control panel display orientation normal
DISPLAY CONTRAST	3 ... 41 ... 100	Set control panel display contrast (default = 41%)	
ERROR MODE	SILENT		Disable error messages and warnings in display (the status LED will still light to indicate fixture status if an error has been detected or the fixture has a warning)
	NORMAL		Enable error messages and warnings in control panel display
HIBERNATION MODE	ON		Enable Hibernation Mode (light output set to zero, all effect movement disabled)
	OFF		Disable Hibernation Mode

STANDALONE	RECORD	SAVE	Capture current scene set via DMX or via fixture's control panel as single standalone scene
	PLAYBACK	ENABLE	Fixture shows standalone scene or show when it is not receiving a DMX or network control signal
		DISABLE	Fixture blacks out when it is not receiving a DMX or network control signal
AURA IN COMPACT MODE	ENABLE		Aura LEDs follow color and intensity of Beam LEDs in Compact and Compact Direct DMX modes.
	DISABLE		Aura LEDs remain OFF in Compact and Compact Direct DMX modes.
AUTO EMPTY WATER	ON		Fixture automatically tilts to empty water when it detects accumulated water in front of head
	OFF		Fixture does not automatically tilt when it detects water
DEFAULT SETTINGS 			
FACTORY DEFAULT	LOAD	ARE YOU SURE? → YES/NO	Return all settings (except calibrations) to factory defaults
CUSTOM 1	LOAD	ARE YOU SURE? → YES/NO	Load Custom Settings 1
	SAVE	ARE YOU SURE? → YES/NO	Save current settings as Custom Settings 1
CUSTOM 2	LOAD	ARE YOU SURE? → YES/NO	Load Custom Settings 2
	SAVE	ARE YOU SURE? → YES/NO	Save current settings as Custom Settings 2
CUSTOM 3	LOAD	ARE YOU SURE? → YES/NO	Load Custom Settings 3
	SAVE	ARE YOU SURE? → YES/NO	Save current settings as Custom Settings 3
INFORMATION 			
POWER ON TIME	TOTAL	0 ... XXX HR	Display number of hours fixture has been powered on since manufacture (not user-resettable)
	RESETTABLE	0 ... XXX HR	Display number of hours fixture has been powered on since last counter reset
		CLEAR COUNTER? → YES/NO	Reset counter

POWER ON CYCLES	TOTAL	0 ... XXX HR	Display number of times fixture has been powered on since manufacture (not user-resettable)
	RESETTABLE	0 ... XX HR	Display number of times fixture has been powered on since last counter reset
		CLEAR COUNTER? → YES/NO	Reset counter
LED ON TIME	BEAM TOTAL	0 ... XX HR	Display number of hours Beam LEDs have been powered on since manufacture (not user-resettable)
	BEAM RESETTABLE	0 ... XX HR	Display number of hours Beam LEDs have been powered on since last counter reset
		CLEAR COUNTER? → YES/NO	Reset counter
	AURA TOTAL	0 ... XX HR	Display number of hours Aura LEDs have been powered on since manufacture (not user-resettable)
	AURA RESETTABLE	0 ... XX HR	Display number of hours Aura LEDs have been powered on since last counter reset
		CLEAR COUNTER? → YES/NO	Reset counter
FW VERSION	XX.XX.XX		Display currently active firmware (fixture software) version
RDM UID	4D50.XXXXXXXXX		Display fixture's unique RDM ID
FAN SPEEDS	HEAD FAN 1 ... BASE FAN 1 ...	0 ... XXX RPM	Scroll to display current speed of cooling fans
TEMPERATURES (since last fixture reset)	UI...LED BOARD	CURRENT / MIN / MAX X C	Scroll through PCB temperature sensors, then display current, minimum and maximum temperature in °C of PCBs since fixture was last reset / powered on
BEAMSHAPER STATUS	ATTACHED		Beamshaper accessory successfully installed / not detected
	NOT ATTACHED		
DMX LIVE			
SOURCE	NO INPUT / DMX / ART-NET / SACN / P3 / UCM		Display current control data source (UCM = Universal Connect Module)
RATE	0 – 44 Hz		DMX transmission speed in packets per second
QUALITY	0 – 100%		Percentage of packets received
START CODE	0 – 255		Value of DMX start code
STROBE ... FX SYNC	XXX		Scroll to see values being received on each DMX channel

TEST			
TEST ALL	BEAM DIMMER ... TILT		Run test sequence of all functions. To test a specific function, use UP/DOWN buttons to scroll through functions. Press ENTER to pause and press again to restart test sequence. Press MENU button to exit test.
TEST LEDS	BEAM DIMMER ... AURA VIRTUAL COLOR WHEEL		Run test sequence of LEDs only. Press MENU button to exit test
TEST EFFECTS	ZOOM		Run mechanical test of Zoom effect (and Beamshaper if fitted). Press ENTER to pause and press again to restart test. Press MENU button to exit test.
	BEAMSHAPER		
TEST PAN/TILT	PAN		Run test sequence of pan functions. Press MENU button to exit test
	TILT		Run test sequence of tilt functions. Press MENU button to exit test
MANUAL CONTROL			
RESET			Reset fixture
STROBE ... AURA P3 MIX			Scroll through effects, then manually control an effect
SERVICE			
ERROR LIST	Empty or up to 20 errors		Show all error and warning messages stored in memory
FAN CLEAN	OFF		Run cooling fans at high speed to help dislodge dust and debris
	ON		
PAN/TILT FEEDBACK	OFF		Enable/disable pan/tilt position feedback system
	ON		
ADJUST Important! For use by (or with guidance from) Martin Service only!	P/T AUTOCALIBRATION	PRESS UP → START	Starts pan and tilt autocalibration. Warning! Head will move! Allow room for full pan/tilt movement.
CALIBRATION	BEAM DIMMER ... AURA BLUE	<i>Calibration range (varies depending on effect)</i>	Scroll through all effects, press Enter to select. Adjust position and press Enter to confirm.
	LOAD DEFAULTS	LOAD	Load factory default calibration settings
	SAVE DEFAULTS	SAVE	Replace factory default calibration settings with current calibration settings

OUTDOOR	ACTION	STOP	Stop all outdoor functions
		DRY OFF SURE? → YES/NO	Activate fixture's drying out function
		SAFE PARKING SURE? → YES/NO	Set fixture to park the head facing downwards to avoid sun damage and accumulated water
		EMPTY HEAD SURE? → YES/NO	Tilt head to drain accumulated water from front of head
	WET STATE		Readout from external sensor on base, indicates Wet or Dry
	WET CURRENT	0 ... XXX MIN	If fixture is wet, how long in minutes it has been wet
	WET LIFETIME	0 ... XXX HR	Total time in minutes the fixture has been wet since manufacture
	ORIENTATION	STANDING	Orientation of fixture base at last power on
HANGING			
CONNECTORS UP			
CONNECTORS DOWN			
SIDEWAYS 90 CW			
SIDEWAYS 90 CCW			
SERVICE LOG	NO DEVICE / EXPORT		No USB device present / Press ENTER to export Service Log data to USB device
	CLEAR	SURE? → YES/NO	Clears all saved error data
USB	NO DEVICE		No USB memory device detected at USB port or no firmware detected on USB memory device
	UPDATING FILES		Fixture updating internal memory from USB memory device
	AVAILABLE FIRMWARE	XX.XX.XX ... XX.XX.XX	Select firmware from versions stored in internal memory. Scroll to select version, then press Enter and confirm your choice to update.

Pixel layout

The 37 Beam LEDs and 234 Aura LEDs in the MAC Aura Raven XIP are numbered as shown below.

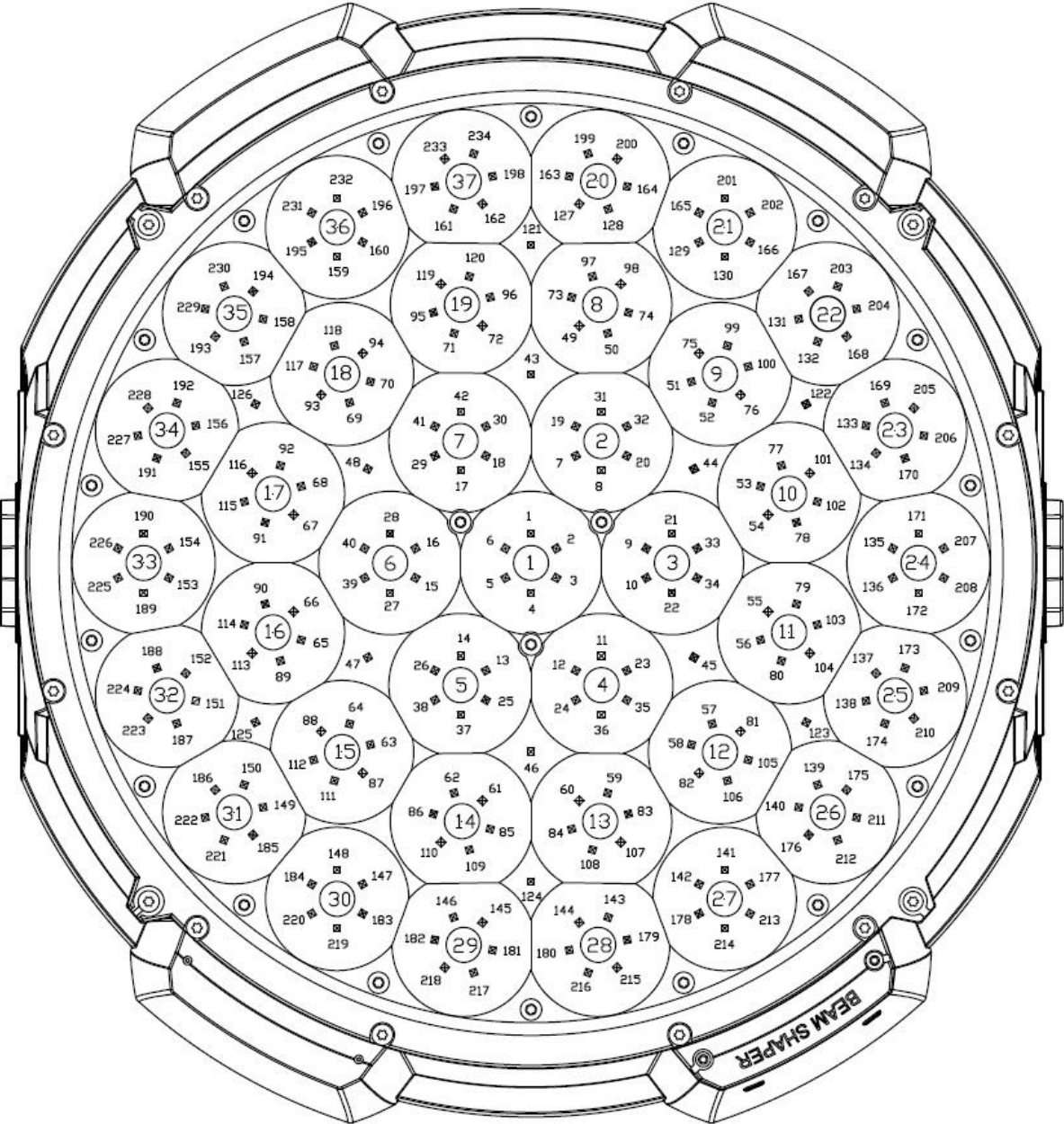

The head is shown with the fixture hanging vertically downwards, display and connectors at back of fixture, pan at 50%, fixture tilted forward.

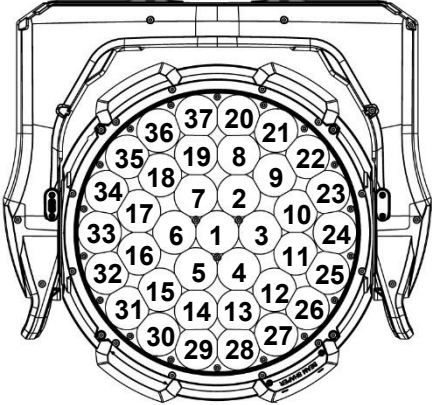

DMX protocols

Compact DMX Mode

22 DMX channels

Channel	DMX Value	Function	Fade type	Default value
1	0–19	Shutter/strobe* Shutter closed	Snap	30
	20–49	Shutter open		
	50–200	Strobe slow → fast		
	201–210	Shutter open		
	211–255	Random strobe slow → fast		
2	0–65535	Dimmer* Closed → Open	Fade	0
3				
4	0–65535	Red* Intensity 0 → 100%	Fade	65535
5				
6	0–65535	Green* Intensity 0 → 100%	Fade	65535
7				
8	0–65535	Blue* Intensity 0 → 100%	Fade	65535
9				
10	0–38	CTC (Color Temperature Control)* Variable from 2000 K to 12850 K in 50 K steps 2000 K 2050 K ... 6500 K ... 12800 K 12850 K	Fade	128
	39			
	...			
	128			
	...			
	254			
255				
11	0–126	Green/Magenta shift (tint)* Shift from Magenta / negative Duv to neutral No shift (native / on black body curve) Shift towards Green / positive Duv	Fade	128
	127–128			
	129–255			

*The Shutter/strobe, Dimmer, RGB, CTC, Green/Magenta shift and Color wheel channels control the Beam and Aura in Compact and Compact Direct modes and control the Beam only in all the other fixture's DMX modes.

Lime is added to the Beam's RGB color mix automatically.

12	0–10	Virtual color wheel* Open	Snap	0
	11–12	Solid colors Moroccan Pink (LEE 790)		
	13–14	Pink (LEE 157)		
	15–16	Special Rose Pink (LEE 332)		
	17–18	Follies Pink (LEE 328)		
	19–20	Fuchsia Pink (LEE 345)		
	21–22	Surprise Pink (LEE 194)		
	23–24	Congo Blue (LEE 181)		
	25–26	Tokyo Blue (LEE 071)		
	27–28	Deep Blue (LEE 120)		
	29–30	Just Blue (LEE 079)		
	31–32	Medium Blue (LEE 132)		
	33–34	Double CT Blue (LEE 200)		
	35–36	Slate Blue (LEE 161)		
	37–38	Full CT Blue (LEE 201)		
	39–40	Half CT Blue (LEE 202)		
	41–42	Steel Blue (LEE 117)		
	43–44	Lighter Blue (LEE 353)		
	45–46	Light Blue (LEE 118)		
	47–48	Medium Blue Green (LEE 116)		
	49–50	Dark Green (LEE 124)		
	51–52	Primary Green (LEE 139)		
	53–54	Moss Green (LEE 089)		
	55–56	Fern Green (LEE 122)		
	57–58	Jas Green (LEE 738)		
	59–60	Lime Green (LEE 088)		
	61–62	Spring Yellow (LEE 100)		
	63–64	Deep Amber (LEE 104)		
	65–66	Chrome Orange (LEE 179)		
	67–68	Orange (LEE 105)		
	69–70	Gold Amber (LEE 021)		
	71–72	Millennium Gold (LEE 778)		
	73–74	Deep Golden Amber (LEE 135)		
	75–76	Flame Red (LEE 164)		
77–78	Red Magenta (LEE 113)			
79–80	Medium Lavender (LEE 343)			
81–82	Pure White (White LEDs only)			
83–84	Pure Red (Red LEDs only)			
85–86	Pure Yellow (Red + Green LEDs only)			
87–88	Pure Green (Green LEDs only)			
89–90	Pure Cyan (Green + Blue LEDs only)			
91–92	Pure Blue (Blue LEDs only)			
93–94	Pure Magenta (Blue + Red LEDs only)			
95–96	Peacock Blue (LEE 115)			
97–98	Dark Lavender (LEE 180)			
99–100	Double CT Orange (LEE 287)			
101–102	Full CT Orange (LEE 204)			
103–104	Half CT Orange (LEE 205)			
105–106	Deep Straw (LEE 015)			
107–190	<i>No function</i>			

*The Shutter/strobe, Dimmer, RGB, CTC, Green/Magenta shift and Color wheel channels control the Beam and Aura in Compact and Compact Direct modes and control the Beam only in all the other fixture's DMX modes.

12 contd.	191–214	Continuous rotation CW, fast → slow Stop (wheel stops at current color) CCW, slow → fast Random slots Fast Medium Slow		
	215–219			
	220–243			
	244–247			
	248–251			
	252–255			
13	0–65535	Zoom Narrow → wide	Fade	32768
14				
15	0 32768 65535	Beamshaper (<i>available when Beamshaper accessory is installed on head</i>) Continuous indexing -180° 0° +180°	Fade	32768
16				
17				
18	0–65535	Pan Left → right	Fade	32768
19				
20	0–65535	Tilt Forward → backward	Fade	32768
21				
Fixture Control/Settings – see ‘Control/Settings DMX channel’ on page 51				
22	0 1–127 128 129–254 255	LED PWM frequency <i>No function</i> Variable -2% → 0% 2400 Hz Variable 0% → +2% High Speed PWM (19200 Hz)	Snap	128

Basic DMX Mode

38 DMX channels

Channel	DMX Value	Function	Fade type	Default value
Channels 1 – 22 as in Compact Mode				
23	0–26	Beam P3 Mix DMX Mode Intensity and colors fully controlled by DMX, P3 pixel data ignored	Snap	0
	27	Mixed Mode Crossfade from DMX control of intensity and color to P3 control of intensity and color:		
	...	<ul style="list-style-type: none"> At 27, intensity and color are still fully controlled by DMX. Between 27 and 228, mix/crossfade from DMX to P3 control. 		
	228	<ul style="list-style-type: none"> At 228, Pure P3 control of intensity and color. 		
	229–255	Video Mode Pixel intensity controlled by P3. Pixel color controlled by DMX.		
24	0–255	FX 1 Select FX Selection 1 -255	Snap	0
25	0–126 127–128 129–255	FX 1 Adjust Reversed fast → slow Stop Forwards slow → fast	Fade	128
26	0–255	FX 2 Select FX Selection 1 -255	Snap	0
27	0–126 127–128 129–255	FX 2 Adjust Reversed fast → slow Stop Forwards slow → fast	Fade	128
28	0	FX Synchronization No sync	Snap	36
	1–35	Fixture offset (shift 10° → 350°)		
	36	Synchronized		
	37–100	<i>No function</i>		
	101–120	Random start (FX1 adjust channel controls overall speed)		
	121–140	Random duration		
	141–255	<i>No function</i>		
Aura backlight control (all Aura LEDs together)				
29	0–19	Aura strobe/shutter Shutter closed	Snap	30
	20–49	Shutter open		
	50–200	Strobe slow → fast		
	201–210	Shutter open		
	211–255	Random strobe slow → fast		
30	0–65535	Aura dimmer	Fade	0
31		Closed → Open		

32	0–255	Aura Red Intensity 0 → 100%	Fade	255
33	0–255	Aura Green Intensity 0 → 100%	Fade	255
34	0–255	Aura Blue Intensity 0 → 100%	Fade	255
35	0–38 39 ... 128 ... 254 255	Aura CTC (Color Temperature Control) Variable from 2000 K to 12850 K in 50 K steps 2000 K 2050 K ... 6500 K ... 12800 K 12850 K	Fade	128
36	0–126 127–128 129–255	Aura Green/Magenta shift (tint) Shift from Magenta / negative Duv to neutral No shift (native / on black body curve) Shift towards Green / positive Duv	Fade	128
37	0–10 11–12 13–14 15–16 17–18 19–20 21–22 23–24 25–26 27–28 29–30 31–32 33–34 35–36 37–38 39–40 41–42 43–44 45–46 47–48 49–50 51–52 53–54 55–56 57–58 59–60 61–62 63–64 65–66 67–68 69–70 71–72 73–74 75–76	Aura virtual color wheel Open Solid colors Moroccan Pink (LEE 790) Pink (LEE 157) Special Rose Pink (LEE 332) Follies Pink (LEE 328) Fuchsia Pink (LEE 345) Surprise Pink (LEE 194) Congo Blue (LEE 181) Tokyo Blue (LEE 071) Deep Blue (LEE 120) Just Blue (LEE 079) Medium Blue (LEE 132) Double CT Blue (LEE 200) Slate Blue (LEE 161) Full CT Blue (LEE 201) Half CT Blue (LEE 202) Steel Blue (LEE 117) Lighter Blue (LEE 353) Light Blue (LEE 118) Medium Blue Green (LEE 116) Dark Green (LEE 124) Primary Green (LEE 139) Moss Green (LEE 089) Fern Green (LEE 122) Jas Green (LEE 738) Lime Green (LEE 088) Spring Yellow (LEE 100) Deep Amber (LEE 104) Chrome Orange (LEE 179) Orange (LEE 105) Gold Amber (LEE 021) Millennium Gold (LEE 778) Deep Golden Amber (LEE 135) Flame Red (LEE 164)	Snap	0

	77–78 79–80 81–82 83–84 85–86 87–88 89–90 91–92 93–94 95–96 97–98 99–100 101–102 103–104 105–106 107–190 191–214 215–219 220–243 244–247 248–251 252–255	Red Magenta (LEE 113) Medium Lavender (LEE 343) Pure White (White LEDs only) Pure Red (Red LEDs only) Pure Yellow (Red + Green LEDs only) Pure Green (Green LEDs only) Pure Cyan (Green + Blue LEDs only) Pure Blue (Blue LEDs only) Pure Magenta (Blue + Red LEDs only) Peacock Blue (LEE 115) Dark Lavender (LEE 180) Double CT Orange (LEE 287) Full CT Orange (LEE 204) Half CT Orange (LEE 205) Deep Straw (LEE 015) <i>No function</i> Continuous rotation CW, fast → slow Stop (wheel stops at current color) CCW, slow → fast Random slots Fast Medium Slow		
38	0–26 27–228 229–255	Aura P3 Mix DMX Mode Intensity and colors fully controlled by DMX, P3 pixel data ignored Mixed Mode Crossfade from DMX control of intensity and colors to P3 control of intensity and color: <ul style="list-style-type: none"> • At 27, intensity and colors are still fully controlled by DMX. • Between 28 and 227, you mix/crossfade from DMX to P3 control. • At 228, Pure P3 control of intensity and color. Video Mode Pixel intensity controlled by P3. Pixel color controlled by DMX.	Snap	0

Extended DMX Mode

149 DMX channels

Channel	DMX Value	Function	Fade type	Default value
Channels 1 – 38 as in Basic Mode				
<i>37 x RGB channels = 111 channels for individual RGB Beam pixel control</i>				
39	0–255	<i>Beam pixel 1 Red Intensity 0 → 100%</i>	<i>Fade</i>	<i>0</i>
40	0–255	<i>Beam pixel 1 Green Intensity 0 → 100%</i>	<i>Fade</i>	<i>0</i>
41	0–255	<i>Beam pixel 1 Blue Intensity 0 → 100%</i>	<i>Fade</i>	<i>0</i>
...	<i>Fade</i>	<i>0</i>
147	0–255	<i>Beam pixel 37 Red Intensity 0 → 100%</i>	<i>Fade</i>	<i>0</i>
148	0–255	<i>Beam pixel 37 Green Intensity 0 → 100%</i>	<i>Fade</i>	<i>0</i>
149	0–255	<i>Beam pixel 37 Blue Intensity 0 → 100%</i>	<i>Fade</i>	<i>0</i>

Beam pixel numbering, Extended DMX Mode

Extended DMX mode adds individual RGB control of the 37 Beam pixels. Lime is added to the Beam's RGB color mix automatically. Individual pixel control is combined with the global RGB Beam control channels using HTP (highest DMX value takes priority).

The Beam pixels are numbered as shown below (fixture hanging downwards, display and connectors at back of fixture, pan at 50%, fixture tilted forward).

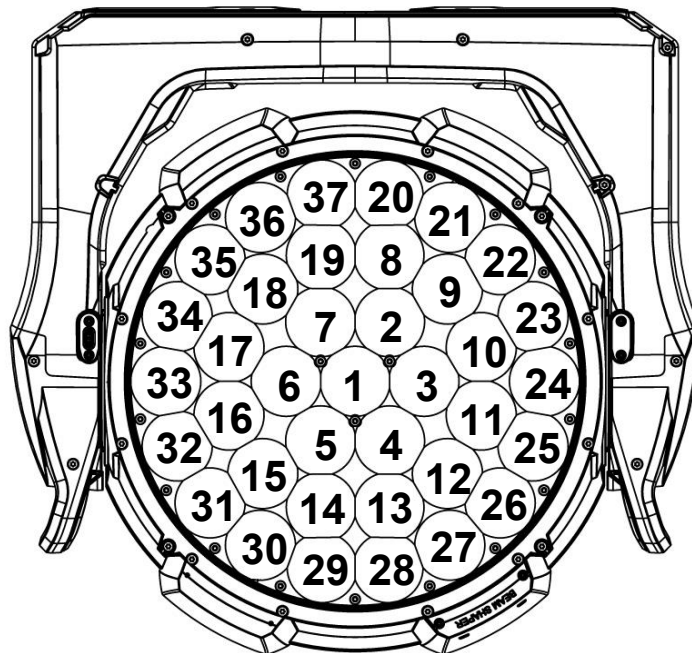

Ludicrous DMX Mode

266 DMX channels

Channel	DMX Value	Function	Fade type	Default value
Channels 1 – 149 as in Extended Mode				
117 channels for Aura control in segments				
150	0–255	Aura pixels around Beam pixel 1 Red Intensity 0 → 100%	Fade	0
151	0–255	Aura pixels around Beam pixel 1 Green Intensity 0 → 100%	Fade	0
152	0–255	Aura pixels around Beam pixel 1 Blue Intensity 0 → 100%	Fade	0
...	Fade	0
264	0–255	Second Aura ring Red Intensity 0 → 100%	Fade	0
265	0–255	Second Aura ring Green Intensity 0 → 100%	Fade	0
266	0–255	Second Aura ring Blue Intensity 0 → 100%	Fade	0

Ludicrous DMX Mode gives the same control options as Extended mode plus RGB control of the 234 Aura backlight pixels in 39 segments:

- RGB control of each group of six Aura LEDs around each Beam pixel 1 – 37 as one segment (37 segments x 3 colors = 111 channels), plus
- RGB control of the inner Aura ring of 6 x LEDs as one segment (x 3 colors = 3 channels), plus
- RGB control of the second Aura ring of 6 x LEDs as one segment (x 3 colors = 3 channels).

The segments are numbered as shown below (fixture hanging downwards, display and connectors at back of fixture, pan at 50%, fixture tilted forward).

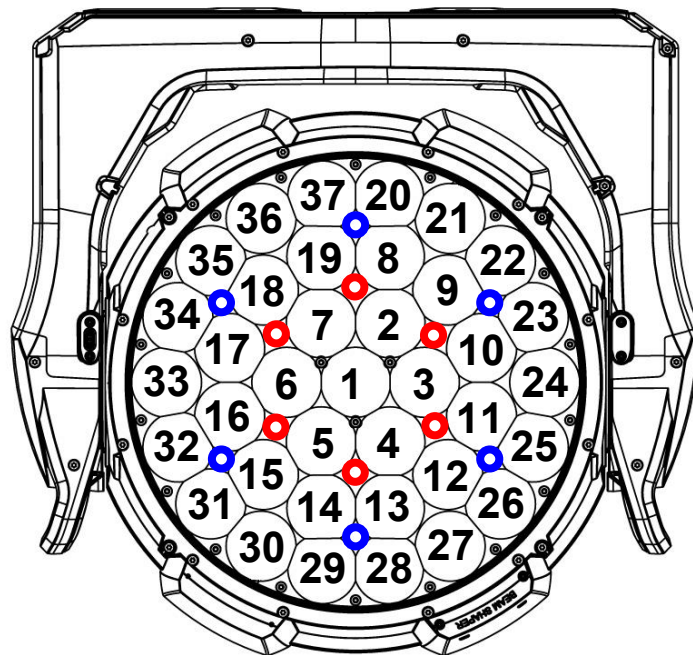
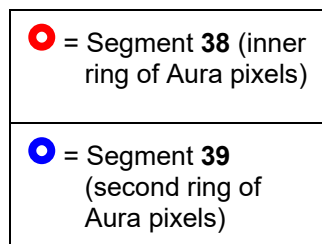

Plaid DMX Mode

851 DMX channels

Plaid Mode uses more than 512 DMX channels, so it is only available when the fixture is controlled by Art-Net, sACN or Martin P3.

Channel	DMX Value	Function	Fade type	Default value
Channels 1 – 149 as in Extended Mode				
<i>702 channels for individual RGB control of all 234 Aura pixels</i>				
150	0–255	<i>Aura pixel 1 Red Intensity 0 → 100%</i>	<i>Fade</i>	<i>0</i>
151	0–255	<i>Aura pixel 1 Green Intensity 0 → 100%</i>	<i>Fade</i>	<i>0</i>
152	0–255	<i>Aura pixel 1 Blue Intensity 0 → 100%</i>	<i>Fade</i>	<i>0</i>
...	<i>Fade</i>	<i>0</i>
849	0–255	<i>Aura pixel 234 Red Intensity 0 → 100%</i>	<i>Fade</i>	<i>0</i>
850	0–255	<i>Aura pixel 234 Green Intensity 0 → 100%</i>	<i>Fade</i>	<i>0</i>
851	0–255	<i>Aura pixel 234 Blue Intensity 0 → 100%</i>	<i>Fade</i>	<i>0</i>

Plaid DMX Mode gives the same control options as Extended mode plus RGB control of all of the 234 Aura backlight pixels. The Beam and Aura pixels are numbered as shown in 'Pixel layout' on page 40.

Compact Direct DMX Mode

22 DMX channels

Channel	DMX Value	Function	Fade type	Default value
1	0–19	Strobe/shutter* Shutter closed Shutter open Strobe slow → fast Shutter open Random strobe slow → fast	Snap	30
	20–49			
	50–200			
	201–210			
	211–255			
2	0–65535	Dimmer* Closed → Open	Fade	0
3				
4	0–65535	Red* Intensity 0 → 100%	Fade	65535
5				
6	0–65535	Green* Intensity 0 → 100%	Fade	65535
7				
8	0–65535	Blue* Intensity 0 → 100%	Fade	65535
9				
10	0–65535	Lime* Intensity 0 → 100%	Fade	65535
11				
12	<i>No function</i>			
13	0–65535	Zoom Narrow → Wide	Fade	32768
14				
15	0 32768 65535	Beamshaper (<i>available when Beamshaper accessory is installed on head</i>) Continuous indexing -180° 0° +180°	Fade	32768
16				
17	0–65535	Pan Left → right	Fade	32768
18				
19	0–65535	Tilt Forward → backward	Fade	32768
20				
21	Fixture Control/Settings – see ‘Control/Settings DMX channel’ on page 51			
22	0	LED PWM frequency <i>No function</i> Variable -2% → 0% 2400 Hz Variable 0% → +2% High Speed PWM (19200 Hz)	Snap	128
	1–127			
	128			
	129–254			
	255			

*The Strobe/Shutter, Dimmer, Red, Green, Blue and Lime channels control the Beam and Aura together in Compact Direct Mode.

It is possible to disable the Aura backlight completely in Compact Direct Mode using the DMX Control/Settings channel, fixture's control panel, RDM, NFC or Martin P3.

Control/Settings DMX channel

The table below lists the control/settings functions available via DMX on channel 21 in all the fixture's DMX modes.

The commands on the Control/Settings channel must be held for a certain number of seconds in order to implement them. The required number of seconds is indicated after each command.

Channel	DMX value	Function	Fade type	Default value
21	0–9	<i>No function, hold zero for 5 secs. to exit calibration function</i>	Snap	0
	10–14	Reset fixture (5 sec.)		
	15–16	<i>No function</i>		
	17	Reset Beam (5 sec.)		
	18	Reset pan and tilt (5 sec.)		
	19–22	<i>No function</i>		
	23	Linear dimmer curve (1 sec.)		
	24	Square law dimmer curve (default, 1 sec.)		
	25	Inverse square law dimmer curve (1 sec.)		
	26	S-Curve dimmer curve (1 sec.)		
	27	Pan and tilt speed = Standard (default, 1 sec.)		
	28	Pan and tilt speed = Fast (1 sec.)		
	29	Pan and tilt speed = Smooth (1 sec.)		
	30–35	<i>No function</i>		
	36	Enable video tracking (1 sec.)		
	37	Disable video tracking (default, 1 sec.)		
	38	Extended Gamut color mode (default, 1 sec.)		
	39	Calibrated color mode (1 sec.)		
	40–51	<i>No function</i>		
	52	Control panel display = ON (default, 1 sec.)		
	53	Control panel display = OFF		
	54	Regulated fan speed, fixed light output intensity (default, 1 sec.)		
	55	Full fan speed, regulated light output intensity (1 sec.)		
	56	Medium fan speed, regulated light output intensity (1 sec.)		
	57	Low fan speed, regulated light output intensity (1 sec.)		
	58	Ultra-low fan speed, regulated light output intensity (1 sec.)		
	59–60	<i>No function</i>		
	61	Hibernation = ON (5 sec.)		
	62	Hibernation = OFF (default, 5 sec.)		
	63–64	<i>No function</i>		
	65	Pan and tilt limits = ON (5 sec.)		
	66	Pan and tilt limits = OFF (default, 5 sec.)		
	67	Store lower pan limit (5 sec.)		
	68	Store upper pan limit (5 sec.)		
	69	Store lower tilt limit (5 sec.)		
70	Store upper tilt limit (5 sec.)			
71	Reset pan and tilt limits (1 sec.)			
72	Tungsten emulation = ON (1 sec.)			
73	Tungsten emulation = OFF (default, 1 sec.)			

74	Standalone scene capture: record scene (5 sec.)		
75	Enable standalone operation (5 sec.)		
76	Disable standalone operation (default, 5 sec.)		
77–91	<i>No function</i>		
92	Compact mode Aura = ON		
93	Compact mode Aura = OFF (default, 1 sec.)		
94–99	<i>No function</i>		
100	Enable calibration (5 sec.)		
101	Store pan and tilt calibration (5 sec.)		
102	Store dimmer calibration (5 sec.)		
103–113	<i>No function</i>		
114	Store zoom calibration (5 sec.)		
115–198	<i>No function</i>		
199	Reset all calibration values to factory default (5 sec.)		
200–207	<i>No function</i>		
208	Auto empty water = ON (1 sec.)		
209	Auto empty water = OFF (default, 1 sec.)		
210	Outdoor: stop actions (default, 1 sec.)		
211	Outdoor: drain water from front of head (1 sec.)		
212	Outdoor: start drying off procedure (stops when sequence is complete or if DMX value 210 is sent, 1 sec.)		
213	Outdoor: safe parking (1 sec.)		
214–255	<i>No function</i>		

FX

The table below lists the pre-programmed dynamic FX (effect macros) available in Basic, Extended, Ludicrous and Plaid Modes in the MAC Aura Raven XIP.

To control the FX:

- Select an effect, or two effects that can run simultaneously, using DMX channels 24 and 26 by sending the values listed in the table.
- Adjust effect speed (and other parameters depending on the effect selected) using channels 25 and 27.
- Adjust synchronization of effects across different fixtures on channel 28.

Effects types

Beam intensity FX (1-13)

These FX modulate the intensity of the Beam LEDs while maintaining the color set by the RGB channels and P3 pixels. The color selected on the Beam virtual color wheel is used as background color.

Beam pixel intensity FX (14-69)

These FX use individual Beam pixels for animated effects while maintaining the color(s) set by the RGB channels, RGB pixel channels and P3 pixels. The color selected on the Beam virtual color wheel is used as background color.

Beam color FX (70-97)

These Beam effects override the color(s) set on the RGB channels, virtual color wheel and P3 pixels.

Beam color modifier FX (98-103)

These Beam effects shift the color(s) set on the RGB channels, virtual color wheel and P3 pixels.

Beam timing (video slo-mo) FX (104)

This effect modifies the timing of the Beam.

Aura intensity FX (105-117)

These FX modulate the intensity of all Aura LEDs together while maintaining the color(s) set by the RGB channels, RGB pixel channels and P3 pixels. The color selected on the Aura virtual color wheel is used as background color.

Aura pixel intensity FX (118-183)

These FX use individual Aura pixels for animated effects while maintaining the color(s) set by the RGB channels, RGB pixel channels and P3 pixels. The color selected on the Aura virtual color wheel is used as background color.

Aura pixel color FX (184-211)

These FX override the Aura color(s) set by the RGB channels, RGB pixel channels, virtual color wheel and P3 pixels.

Aura color modifier FX (212-219)

These FX shift the Aura color(s) set by the RGB channels, RGB pixel channels, virtual color wheel and P3 pixels.

Aura timing (video slo-mo) FX (220)

This effect modifies the timing of the Aura backlight.

Beam and Aura combined FX (221-227)

These effects use the Beam and Aura either alternating or together.

Zoom FX (228-237)

These effects modify the Zoom, sometimes in combination with the Dimmer.

Pan and tilt FX (238-249)

These FX modulate the position of the head around the home position set by the Pan and Tilt channels.

Masks and Looks (250-255)

These FX contain a library of static intensity masks and static color patterns. Use the FX Adjust channel to select a mask/look from the library.

FX table

DMX Value	Effect
0	No FX
Beam Intensity – All	
1	Beam Strobe Pulse Width (when Strobe is activated on Channel 1)
2	Beam Blackout Strobe
3	Beam 2 x Strobe
4	Beam 3 x Strobe
5	Beam 4 x Strobe
6	Beam Up, Down, Flash
7	Beam Up, Down, Flash Second Color
8	Beam Up, Flash, Down, Flash
9	Beam Up, Flash, Down, Flash Second Color
10	Beam Random Levels
11	Beam Movie Flicker
12	Beam Atomic Lighting
13	Beam Thunderstorm
Beam Intensity – Pixels	
14	Beam Pixel Killer Static
15	Beam Sparkle Stars
16	Beam Sparkle Stars Heavy
17	Beam Lightning Flashes Random
18	Beam Lightning Flashes Random Heavy
19	Beam Starfield
20	Beam Fiberoptic
21	Beam Noise
22	Beam Build Up/Down Random Step
23	Beam Build Up/Down Random Fade
24	Beam Random 1 Pixel Step
25	Beam Random 1 Pixel Fade
26	Beam Random 3 Pixel Step
27	Beam Random 3 Pixel Fade
28	Beam Random 6 Pixel Step
29	Beam Random 6 Pixel Fade
30	Beam Random 12 Pixel Step
31	Beam Random 12 Pixel Fade
32	Beam Split Static
33	Beam Split Rotating Step
34	Beam Split Rotating Fade
35	Beam In-Out Step
36	Beam In-Out Fade
37	Beam Waterdrop
38	Beam Radar Spin Step
39	Beam Radar Spin Fade
40	Beam Line Spin Step
41	Beam Line Spin Fade
42	Beam Cross Spin Step
43	Beam Cross Spin Fade
44	Beam Slice Pie 1 Spin Step
45	Beam Slice Pie 1 Spin Fade
46	Beam Slice Pie 2 Spin Step
47	Beam Slice Pie 2 Spin Fade
48	Beam Slice Pie 3 Spin Step
49	Beam Slice Pie 3 Spin Fade

DMX Value	Effect
50	Beam Random Slice Pie Step
51	Beam Random Slice Pie Fade
52	Beam Snake 1 Pixel Step
53	Beam Snake 1 Pixel Fade
54	Beam Snake 3 Pixel Step
55	Beam Snake 3 Pixel Fade
56	Beam Snake 6 Pixel Step
57	Beam Snake 6 Pixel Fade
58	Beam Snake 12 Pixel Step
59	Beam Snake 12 Pixel Fade
60	Beam Vertical Line Step
61	Beam Vertical Line Fade
62	Beam Vertical Line Bounce Step
63	Beam Vertical Line Bounce Fade
64	Beam Horizontal Line Step
65	Beam Horizontal Line Fade
66	Beam Horizontal Line Bounce Step
67	Beam Horizontal Line Bounce Fade
68	Beam Vertical + Horizontal Line Bounce Step
69	Beam Vertical + Horizontal Line Bounce Fade
Beam Color – Pixels	
70	Beam Rainbow Pixels Step
71	Beam Rainbow Pixels Fade
72	Beam Rainbow Pixels Step Random
73	Beam Rainbow Pixels Fade Random
74	Beam Red-Yellow Pixels Step
75	Beam Red-Yellow Pixels Fade
76	Beam Yellow-Green Pixels Step
77	Beam Yellow-Green Pixels Fade
78	Beam Green-Cyan Pixels Step
79	Beam Green-Cyan Pixels Fade
80	Beam Cyan-Blue Pixels Step
81	Beam Cyan-Blue Pixels Fade
82	Beam Blue-Magenta Pixels Step
83	Beam Blue-Magenta Pixels Fade
84	Beam Magenta-Red Pixels Step
85	Beam Magenta-Red Pixels Fade
86	Beam Red White Blue Step
87	Beam Red White Blue Fade
88	Beam Fire
89	Beam Water
90	Beam Swimming Pool
91	Beam Ice
92	Beam Hot and Cold
93	Beam Warm and Fuzzy
94	Beam Silver and Gold
95	Beam Gold and Silver
96	Beam Electric Arc
97	Beam Plasma

DMX Value	Effect
Beam Color Modifier	
98	Beam Spectrum Shifter Static
99	Beam Spectrum Shifter Step
100	Beam Spectrum Shifter Fade
101	Beam Pixel Spectrum Shifter Random Static
102	Beam Pixel Spectrum Shifter Random Step
103	Beam Pixel Spectrum Shifter Random Fade
Beam Timing	
104	Beam Video Slo-Mo
Aura Intensity – All	
105	Aura Strobe Width (when strobe is activated on channel 29)
106	Aura Blackout Strobe
107	Aura 2 x Strobe
108	Aura 3 x Strobe
109	Aura 4 x Strobe
110	Aura Up, Down, Flash
111	Aura Up, Down, Flash Second Color
112	Aura Up, Flash, Down, Flash
113	Aura Up, Flash, Down, Flash Second Color
114	Aura Random Levels
115	Aura Movie Flicker
116	Aura Atomic Lighting
117	Aura Thunderstorm
Aura Intensity – Pixels	
118	Aura Pixel Killer Static
119	Aura Sparkle Stars
120	Aura Sparkle Stars Heavy
121	Aura Lightning Flashes Random
122	Aura Lightning Flashes Random Heavy
123	Aura Starfield
124	Aura Fiberoptic
125	Aura Noise
126	Aura Build Up/Down Random Step
127	Aura Build Up/Down Random Fade
128	Aura Random 10 LED Step
129	Aura Random 10 LED Fade
130	Aura Random 20 LED Step
131	Aura Random 20 LED Fade
132	Aura Random 40 LED Step
133	Aura Random 40 LED Fade
134	Aura Random 80 LED Step
135	Aura Random 80 LED Fade
136	Aura Split Static
137	Aura Split Rotating Step
138	Aura Split Rotating Fade
139	Aura In-Out Step
140	Aura In-Out Fade
141	Aura Waterdrop
142	Aura Radar Spin Step
143	Aura Radar Spin Fade
144	Aura Line Spin Step
145	Aura Line Spin Fade

DMX Value	Effect
146	Aura Cross Spin Step
147	Aura Cross Spin Fade
148	Aura Slice Pie 1 Spin Step
149	Aura Slice Pie 1 Spin Fade
150	Aura Slice Pie 2 Spin Step
151	Aura Slice Pie 2 Spin Fade
152	Aura Slice Pie 3 Spin Step
153	Aura Slice Pie 3 Spin Fade
154	Aura Random Slice Pie Step
155	Aura Random Slice Pie Fade
156	Aura Snake 1 Group Step
157	Aura Snake 1 Group Fade
158	Aura Snake 3 Group Step
159	Aura Snake 3 Group Fade
160	Aura Snake 6 Group Step
161	Aura Snake 6 Group Fade
162	Aura Snake 12 Group Step
163	Aura Snake 12 Group Fade
164	Aura Nightrider Vertical
165	Aura Nightrider Horizontal
166	Aura Snowflakes Vertical
167	Aura Snowflakes Vertical Heavy
168	Aura Snowflakes Horizontal
169	Aura Snowflakes Horizontal Heavy
170	Aura Rain Vertical
171	Aura Rain Vertical Heavy
172	Aura Rain Horizontal
173	Aura Rain Horizontal Heavy
174	Aura Vertical Line Step
175	Aura Vertical Line Fade
176	Aura Vertical Line Bounce Step
177	Aura Vertical Line Bounce Fade
178	Aura Horizontal Line Step
179	Aura Horizontal Line Fade
180	Aura Horizontal Line Bounce Step
181	Aura Horizontal Line Bounce Fade
182	Aura Vertical + Horizontal Line Bounce Step
183	Aura Vertical + Horizontal Line Bounce Fade
Aura Color – Pixels	
184	Aura Rainbow Pixels Step
185	Aura Rainbow Pixels Fade
186	Aura Rainbow Pixels Step Random
187	Aura Rainbow Pixels Fade Random
188	Aura Red-Yellow Pixels Step
189	Aura Red-Yellow Pixels Fade
190	Aura Yellow-Green Pixels Step
191	Aura Yellow-Green Pixels Fade
192	Aura Green-Cyan Pixels Step
193	Aura Green-Cyan Pixels Fade
194	Aura Cyan-Blue Pixels Step
195	Aura Cyan-Blue Pixels Fade
196	Aura Blue-Magenta Pixels Step

DMX Value	Effect
197	Aura Blue-Magenta Pixels Fade
198	Aura Magenta-Red Pixels Step
199	Aura Magenta-Red Pixels Fade
200	Aura Red White Blue Step
201	Aura Red White Blue Fade
202	Aura Fire
203	Aura Water
204	Aura Swimming pool
205	Aura Ice
206	Aura Hot and cold
207	Aura Warm and fuzzy
208	Aura Silver and gold
209	Aura Gold and silver
210	Aura Electric Arc
211	Aura Plasma
Aura Color – Modifier	
212	Aura Spectrum Shifter Static
213	Aura Spectrum Shifter Step
214	Aura Spectrum Shifter Fade
215	Aura Pixel Spectrum Shifter Random Static
216	Aura Pixel Spectrum Shifter Random Step
217	Aura Pixel Spectrum Shifter Random Fade
218	Aura Tungsten
219	Aura Tungsten Delay
Aura Timing	
220	Aura Video Slo-Mo
Beam and Aura Combined	
221	Beam-Aura Step
222	Beam-Aura Fade
223	Aura Ramp, Beam Flash
224	Beam Ramp, Aura Flash
225	Full Thunderstorm
226	Full Welding
227	Full 3-Step Strobe
Zoom Effects	
228	Zoom Fade In Snap Out
229	Zoom Fade Out Snap In
230	Beam Splash
231	Beam Splash Invert
232	Aura Splash
233	Aura Splash Invert
234	Beam Zoom Snap Out Towards Aura
235	Beam Zoom Fade Out Towards Aura
236	Beam Zoom Snap In Towards Aura
237	Beam Zoom Fade In Towards Aura
Movement Effects	
238	Pan and Tilt Circle Small
239	Pan and Tilt Circle Medium
240	Pan and Tilt Circle Large
241	Pan and Tilt Figure 8 Small
242	Pan and Tilt Figure 8 Medium
243	Pan and Tilt Figure 8 Large

DMX Value	Effect
244	Pan and Tilt Diagonal Line Small
245	Pan and Tilt Diagonal Line Medium
246	Pan and Tilt Diagonal Line Large
247	Pan and Tilt Square Small
248	Pan and Tilt Square Medium
249	Pan and Tilt Square Large
Masks and Looks	
250	Beam Pixel Masks
251	Aura Pixel Masks
252	<i>No function</i>
253	Beam Color Looks
254	Aura Color Looks
255	Complete Color Looks

Pan/tilt and zoom orientation guide

Pan range = 540°

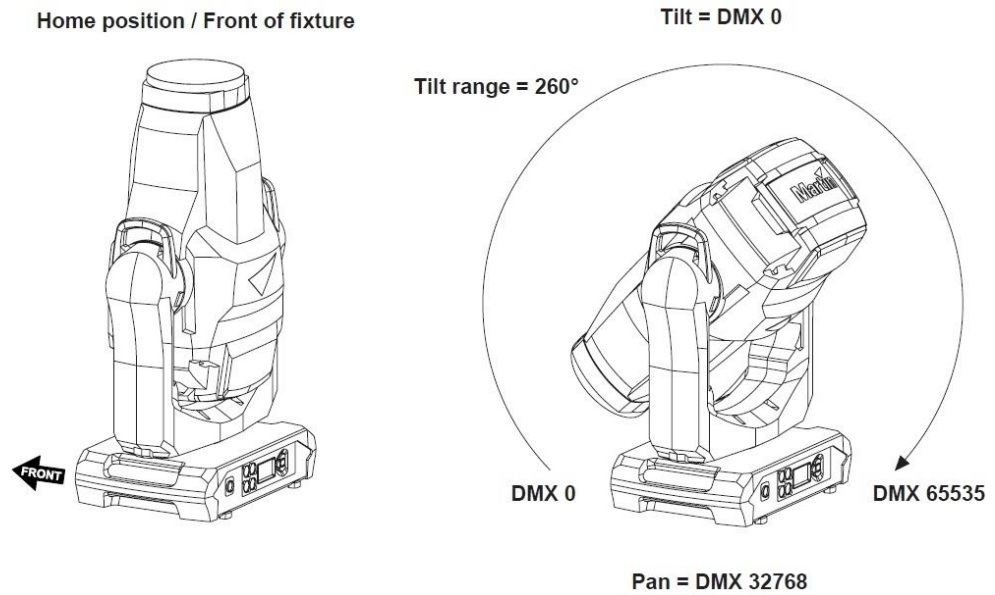
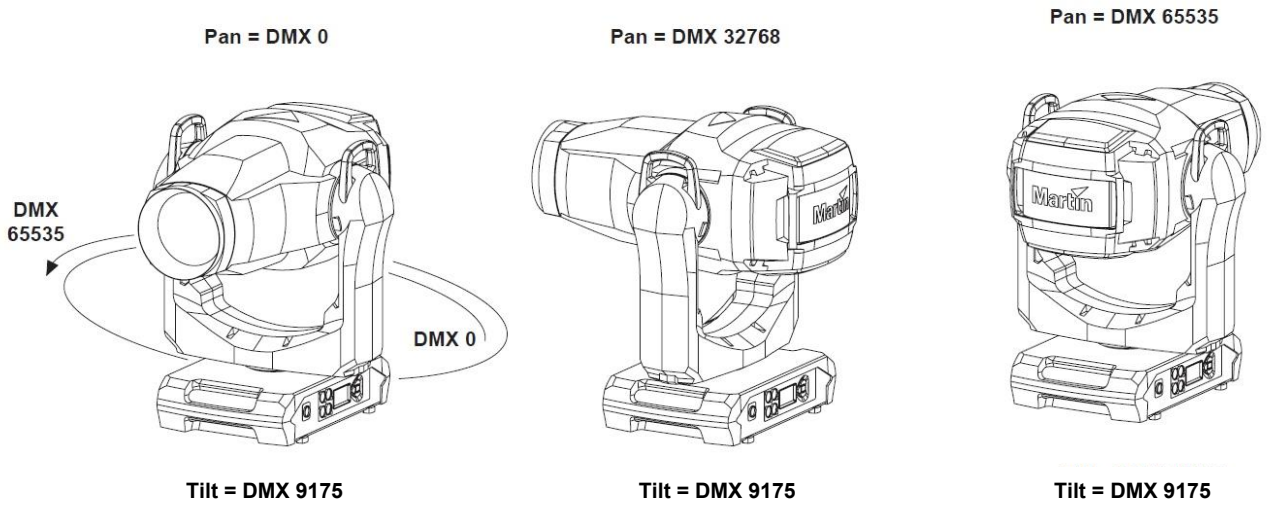

Fixture shown in illustrations is for example purposes only

Tilt = DMX 32768

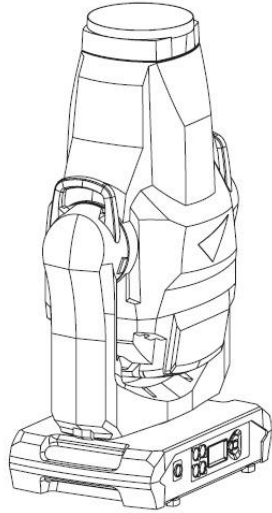

Pan = DMX 32768

Tilt = DMX 65535

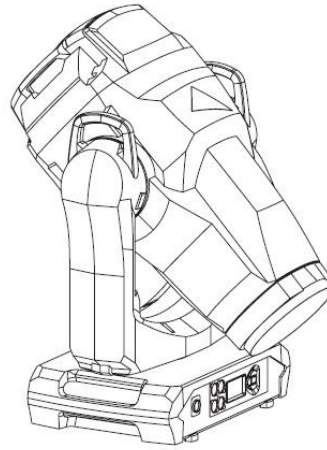

Pan = DMX 32768

Zoom Wide = DMX 65535

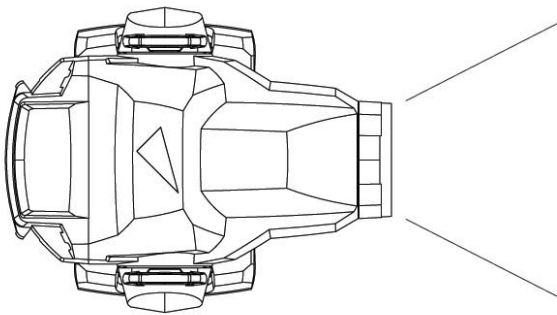

Zoom Narrow = DMX 0

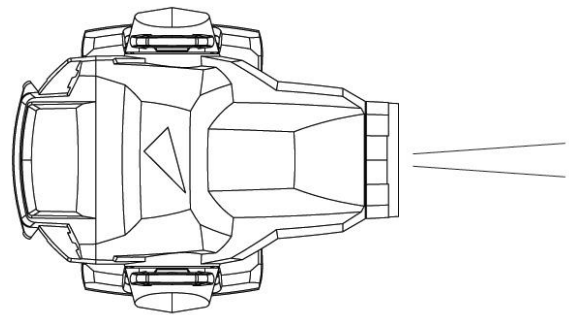

Fixture shown in illustrations is for example purposes only

Service messages

The MAC Aura Raven XIP gives service and maintenance information by displaying a large 3- or 4-character short code and a smaller full-text message in the fixture's display. The short code is visible at a distance, allowing easier reading with the fixture still in the rig, for example, while the full-text message gives more detailed information.

Excessively high temperatures

If any of the temperature sensors reports that the fixture has exceeded its recommended temperature range, the fixture reports a temperature warning and reduces light output to reduce its temperature. If the temperature reaches a dangerous level, light output is shut down completely.

Temperature warnings are canceled and full light output becomes available again as soon as the temperature returns to normal.

Warning messages

Warning messages indicate that either:

- problems might appear in the future if no action is taken, or
- the user needs to pay special attention to a function or procedure when working with the fixture.

The fixture communicates warnings as follows:

- Warning codes are shown continuously in the display and disappear when the user reacts to the warning.
- If more than one warning is detected, all warnings are displayed in sequence.
- If the display is inactive, the fixture's status LED flashes amber to indicate that there is a warning. Activating the display will show the warning.

The possible warning messages are listed below:

Short code	Long message and explanation
AUTW	AURA TMP HIGH LED Aura pixels sensor detects abnormally high operating temperature.*
BANK	BANK NO ACCESS Error unpacking firmware bank during/after software upload. Fixture will continue to operate on existing firmware. Warning message is cleared by a successful software upload or at the next power off/on cycle.
BATM	BATTERY MODE Fixture in battery mode. Certain control menu items are not available.
CTUP	CONNECTORS UPWARD Fixture oriented with connections panel facing upwards.
DRYO	DRYING OUT Drying out function active.
DRYR	DRY OUT FUNC RECOM Drying out function recommended.

EMPW	EMPTYING WATER Head emptying water, pan and tilt temporarily disabled
FOUP	FORCE UPLOAD TO NODES Force firmware upload to nodes (in internal modules)
LDTW	LED DRV TMP HIGH LED Driver PCB sensor detects abnormally high operating temperature.*
LEEP	LED BOARD EEPROM Read/write failure, EEPROM on LED driver board.
LETW	LED BOARD TEMP HIGH LED PCB sensor detects abnormally high operating temperature.*
NFCW	NFC WARNING NFC system unable to access data.
NOUP	NO FW UPLOAD TO NODES Firmware cannot be uploaded to one or more nodes (in internal modules).
PARK	SAFE PARKING Safe parking function active.
PTTW	PT TEMP HIGH Pan/Tilt PCB sensors detect abnormally high operating temperature.*
PUTW	PSU TEMP HIGH PSU sensor detects abnormally high operating temperature.*
SA D	SAFETY DISABLED Safety disabled.
SERV	SERVICE MODE Fixture in service mode.
SRNM	SR NO MISMATCH Mismatch of serial numbers on internal modules. Calibration may be lost.
UITW	UI TEMP HIGH User interface (LCD display and control panel) PCB sensor detects abnormally high operating temperature.*

*High temperature warnings are canceled as soon as temperature returns to normal. If temperature reaches cutoff level, the warning is replaced by a cutoff error message.

Error messages

Error messages indicate that a problem is present. The fixture communicates errors as follows:

- Error messages flash in the display.
- If more than one error is detected, the fixture flashes all errors three times each.
- Errors are shown in the display regardless of display status: they override an inactive display and any other information that the display might be showing.
- If an error is present, the status LED flashes red.

The possible error messages are listed below:

Short code	Long message and explanation
ACER	AURA CALIB ERROR Aura LEDs calibration data missing.
AUTC	AURA TEMP CUTOFF Aura LEDs temperature cutoff activated.
AUTE	AURA TEMP SEN ERROR Aura LEDs temperature sensor error.
BCER	BEAM CALIB ERROR Beam LEDs calibration data missing.
BRER	BEAMSHAPER ROT Beamshaper accessory position error.
CELD	COLOR ENGINE ERR LED DRV LED driver communication error.
CEPT	COM ERR PAN TILT Pan/tilt system communication error.
COLD	FIXTURE COLD Fixture cold. Physical movement of effects is disabled until fixture has warmed up.
FAN	BASE FAN 1 ERR
FAN	BASE FAN 2 ERR
FAN	HEAD FAN 1 ERR
FAN	HEAD FAN 2 ERR
FAN	HEAD FAN 3 ERR
FAN	YOKE FAN ERR
FBEP	PAN FBACK ERR Pan position magnetic indexing system timeout. Fixture is unable to correct pan position (but pan movement will often still be possible).
FBET	TILT FBACK ERR Tilt position magnetic indexing system timeout. Fixture is unable to correct tilt position (but tilt movement will often still be possible).
FBEZ	ZOOM FBACK ERR Zoom effect position magnetic indexing system timeout. Fixture is unable to correct zoom position (but zoom effect will often still be useable).
LDTC	LED TEMP CUTOFF LED temperature cutoff activated.
LDTE	LED TEMP SEN ERR LED temperature sensor error.

LETC	LED BOARD TMP CUTOFF LED PCB temperature sensor cutoff activated.
LETE	LED BOARD SEN ERR LED PCB temperature sensor error.
MMER	MISSING MODULE Impossible to communicate with a module that should be present. Module missing or not correctly connected.
NFCE	NFC ERROR NFC communication not working.
PAER	PAN ERROR Pan position electrical indexing system timeout.
PSER	PAN SENSOR ERROR Fixture unable to retrieve reliable data from pan position sensor.
PTCM	P/T SENSOR ADJUST Pan/tilt sensors are incorrectly adjusted.
PTTC	PT TEMP CUTOFF Pan/tilt PCB temperature cutoff activated.
PTTE	PT TEMP SEN ERROR Pan/tilt PCB temperature sensor error.
PUTC	PSU TEMP CUTOFF PSU temperature cutoff activated.
PUTE	PSU TEMP SEN ERR PSU temperature sensor error.
SEER	ARTNET SOURCES EXCEEDED Number of Art-Net control sources exceeded.
SEER	ETH SOURCES EXCEEDED Number of Ethernet protocol control sources exceeded.
SEER	SACN SOURCES EXCEEDED Number of sACN control sources exceeded.
SLER	SAFETY LOOP Safety loop wire error.
TIER	TILT ERROR Tilt position electrical indexing circuit timeout.
TSER	TILT SENSOR ERR Fixture unable to retrieve reliable data from tilt position sensor.
UELD	UPL ERR LED DRV LED driver upload error.
UEPT	UPLOAD ERR PAN/TILT Firmware cannot be uploaded to pan/tilt system
UITC	UI TEMP CUTOFF User interface module temperature cutoff activated.

UITE	UI TEMP SEN ERR User interface (LCD display and control panel) temperature sensor error.
ZOER	ZOOM ERROR Zoom position error.
ZSER	ZOOM SENSOR ERROR Zoom position sensor error.

Accessories and service procedures

This section gives instructions for service procedures that may be carried out by the user. For any procedure that is not described below or in the MAC Aura Raven XIP Safety and Installation Manual, please contact your Martin supplier for assistance.

Before carrying out service on the fixture, read the 'Safety Information' section of the fixture's Safety and Installation Manual that is included at the end of this User Guide, supplied with the fixture and available for download from the Martin website at www.martin.com. Do not remove any cover from the fixture unless the fixture is in a dry location under dry conditions.

Uploading new firmware

Important! Do not switch the fixture off or disconnect the source of the firmware during an update, or the firmware will be corrupted.

Fixture information and settings are not affected when you upload new firmware to the fixture.

All MAC Aura Raven XIP fixtures that are powered on and connected via a DMX link to the fixture that you update will also have their firmware updated.

If you update firmware to a newer version, check the MAC Aura Raven XIP area of www.martin.com to see whether an updated version of the fixture's User Manual is available for the new firmware.

You can check the currently installed firmware version in the INFORMATION menu in the fixture's control panel. Firmware updates can be downloaded automatically from the Martin cloud using the Martin Companion software suite on a PC connected to the Internet.

You can update the fixture's firmware using one of the following methods:

- A USB memory device inserted into the USB port beside the fixture's control panel.
- A Windows PC running the Martin Companion application with a Martin Companion Cable USB/DMX hardware interface connected either to the fixture's DMX IN socket or to the DMX link.
- A Martin P3 System Controller or Windows PC running the Martin P3-PC application, connected to the fixture(s) via network cables. See the P3 System Controller user manual for more information.

Installing using a USB memory device

The following are required in order to install firmware using a USB flash drive:

- The MAC Aura Raven XIP '.BANK' firmware update file, which the Martin Companion application will download automatically when you run Martin Companion on a PC with an Internet connection.
- A USB flash drive with the firmware update file copied from a PC into the USB flash drive's root directory.

To install the MAC Aura Raven XIP firmware:

1. Download the '.BANK' firmware file from the Martin cloud within the Martin Companion Application and click on **Export USB Stick Firmware...**
2. Read the firmware release notes carefully to check for any instructions or warnings, and copy the firmware file to the root directory of the USB flash drive.
3. Disconnect the DMX data link from the MAC Aura Raven XIP.
4. Insert the USB flash drive into the MAC Aura Raven XIP's USB host socket. The fixture should recognize the USB flash drive and illuminate the display. If the fixture does not recognize the USB flash drive, navigate to **SERVICE** → **USB** in the fixture's control panel.
5. **AVAILABLE FIRMWARE** will appear in the display. You can now scroll through the firmware versions available.
6. To install a firmware version, select it and press ENTER. The MAC Aura Raven XIP asks you to confirm installation of the new firmware. Press ENTER to confirm and press MENU to exit without confirming.
7. Allow the fixture to install the firmware and reboot. Do not remove the USB flash drive until the fixture has successfully rebooted.

8. Remove the USB flash drive. The newly-installed firmware version will now be displayed in the **INFORMATION** menu.
9. Reconnect the data link.

Installing using a PC and Martin Companion

The following are required in order to install firmware using a PC:

- A Windows PC running the latest version of the Martin Companion software suite (available for download free of charge from the Martin website at www.martin.com).
- The MAC Aura Raven XIP firmware file, which the Martin Companion application will download automatically when you run Martin Companion on a PC with an Internet connection.
- The Martin Companion Cable USB-DMX hardware interface, available from your Martin supplier by ordering P/N 91616091.

To install the MAC Aura Raven XIP firmware using a PC and Martin Companion:

1. Apply power to the MAC Aura Raven XIP fixture(s) and allow it to boot.
2. Connect the Martin Companion Cable's USB connector to a USB port on your PC. Connect the Martin Companion Cable's XLR connector either directly to the fixture's DMX IN connector or to the DMX link.
3. Start the PC and launch the Martin Companion application. Check that Martin Companion correctly detects the Martin Companion Cable (the USB status icon in the top right-hand corner of the window should be active).
4. Locate the latest MAC Aura Raven XIP firmware in Martin Companion's **Firmware** window.
5. Start the firmware update by clicking **Update Firmware** in Martin Companion. Do not disconnect the Martin Companion Cable or power off the fixture(s) until the upload is complete and the fixture(s) has successfully rebooted.
6. If you are updating multiple fixtures over a DMX link, check that they have all rebooted correctly.

Installing a UCM (Universal Connect Module)

Universal Connect Modules available from various manufacturers can be installed on the MAC Aura Raven XIP. The module mounts onto the fixture's connections/control panel in place of the battery/USB port cover.

To install a Universal Connect Module:

1. See illustration below. Remove the two screws (arrowed) from the plastic battery/USB port cover and lever the cover gently away from the connections/control panel with a plastic lever (or flat-headed screwdriver). This cover mates with the fixture's USB port with a rubber seal, so there will be some resistance when you lever the cover off. Do not remove the yellow rubber battery cover that becomes visible when you remove the plastic battery/USB port cover.

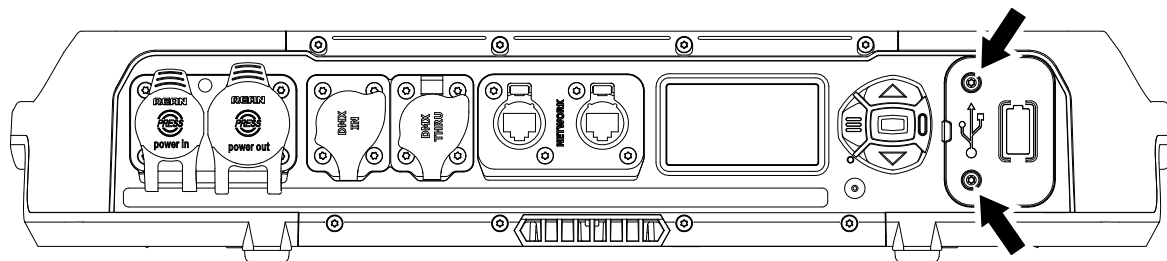

2. See illustration on right. Line up the USB-C connector on the back of the Universal Connect Module with the fixture's USB port and push the module into position on the connections/control panel so that the USB connector mates with the USB port in the fixture. Reinstall the two screws (arrowed) from the original cover. You will probably need to unscrew the antenna temporarily for easy access to the lower of the two screws.

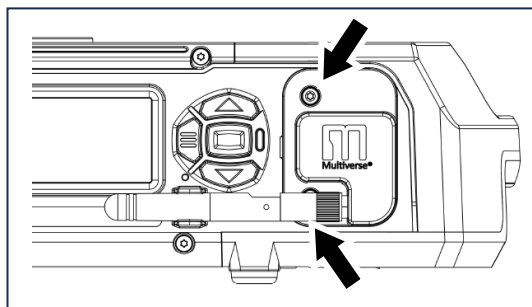

3. See photos on right. Install the supplied antenna holder clip on the fixture by fastening its supplied screw into the hole provided (arrowed).

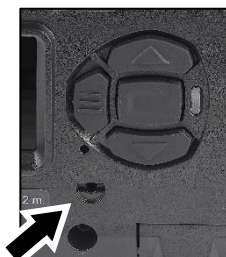

MAC Aura Raven XIP

Safety and Installation Manual



Martin[®]

Dimensions

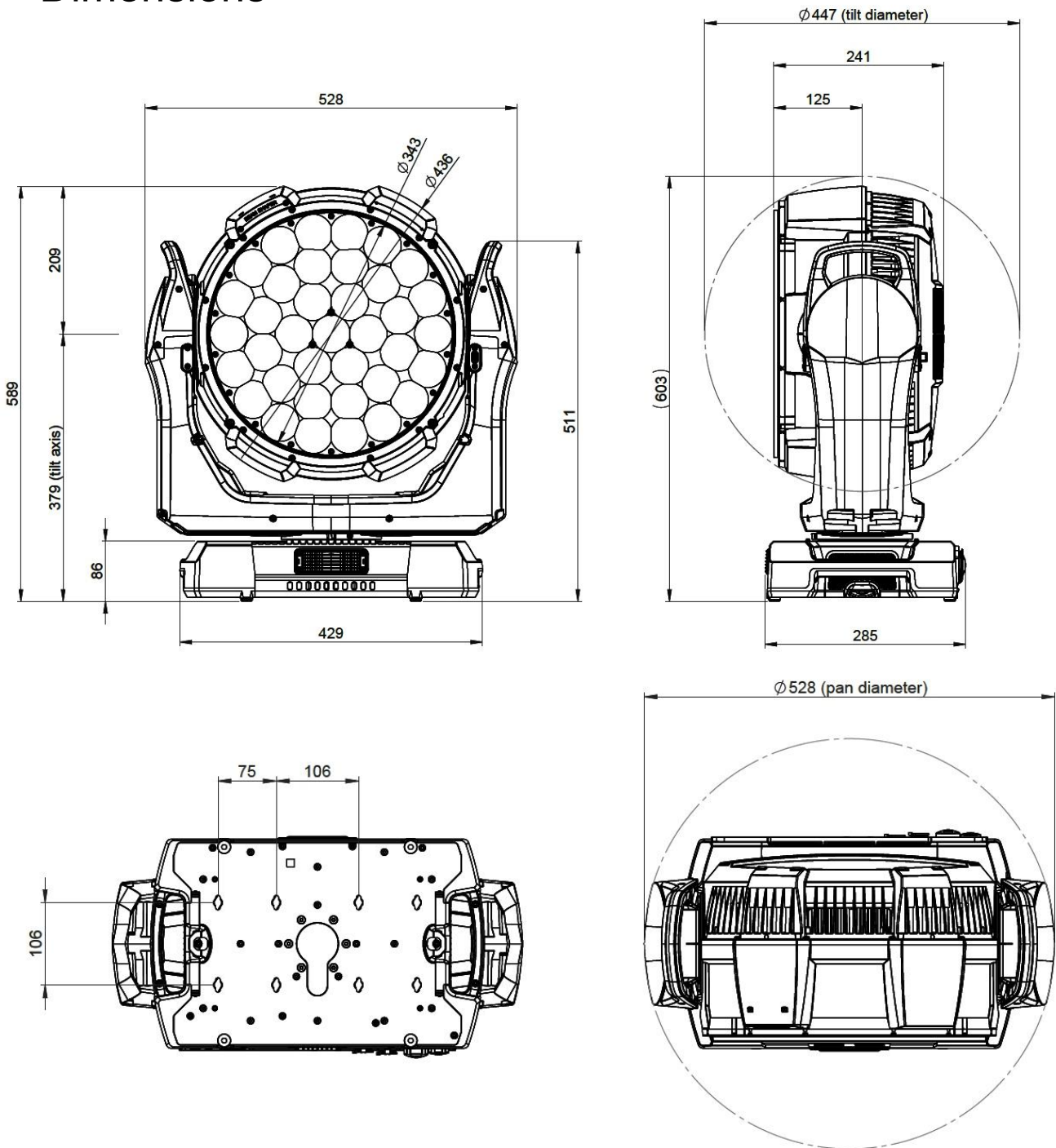

All dimensions are in millimeters

©2025-2026 HARMAN PROFESSIONAL DENMARK ApS. All rights reserved. Features, specifications and appearance are subject to change without notice. HARMAN PROFESSIONAL DENMARK ApS and all affiliated companies disclaim liability for any injury, damage, direct or indirect loss, consequential or economic loss or any other loss occasioned by the use of, inability to use or reliance on the information contained in this document. Martin is a registered trademark of HARMAN PROFESSIONAL DENMARK ApS registered in the United States and/or other countries.

HARMAN PROFESSIONAL DENMARK ApS, Olof Palmes Allé 44, 8200 Aarhus N, Denmark
HARMAN PROFESSIONAL, INC. 8500 Balboa Blvd., Northridge CA 91325, USA

www.martin.com

MAC Aura Raven XIP Safety and Installation Manual, English, Revision C

Table of contents

Dimensions	2
Safety information	4
Introduction	10
Packing and unpacking	10
Condensation	10
Before using the product for the first time	10
Applying mains power	10
Cold starting	11
Overview	11
Tilt lock	11
Physical installation	12
Installation location	12
Installation environment	12
Avoiding damage from other light sources	12
Standing the fixture on a flat surface	12
Mounting the fixture on a truss	13
Securing with a safety cable	14
AC mains power	15
Linking MAC Aura Raven XIP fixtures to power in a chain at 100-120 V	15
Linking MAC Aura Raven XIP fixtures to power in a chain at 200-240 V	15
Connecting to power	16
Data connections	16
Service and maintenance	17
Service mode	17
Cleaning	17
Cleaning air filters	18
Battery replacement	18
Lubrication	19
Specifications and compliance	20

Safety information



WARNING!

Read the safety precautions in this manual before installing, powering, operating or servicing this product.

The following symbols are used to identify important safety information on the product and in this manual:



Warning!

***Safety hazard.
Risk of severe
injury or death.***



Warning!

***Hazardous
voltage. Risk
of lethal or
severe electric
shock.***



Warning!

Fire hazard.



Warning!

***Burn hazard.
Hot surface.
Do not touch.***



Warning!

***Intense light
emission.***



Warning!

***See user
documentation.***



Warning! Risk Group 2 product according to EN 62471 and IEC/TR 62778 (see “Protection from eye injury” on page 8 for full details). Possibly hazardous radiation emitted from this product. May be harmful to the eyes. Do not stare directly into the light output from the product. Position the product so that prolonged staring into the product at a distance closer than 67.5 m (221.5 ft.) is not expected. Do not view the light output with optical instruments or any device that may concentrate the beam.



The MAC Aura Raven XIP lighting fixture presents risks of severe injury or death due to fire and burn hazards, electric shock and falls if the safety precautions in this manual are not followed.



You may carry out external cleaning and service as described in the fixture’s user documentation, following the warnings and instructions provided, but any service operation not described in this Safety and Installation manual or in the fixture’s User Manual must be referred to an authorized Martin service technician.

The MAC Aura Raven XIP is for professional use as a stage light only. It is not for household or general lighting applications. Respect all locally applicable laws, codes and regulations when installing, powering, operating or servicing the fixture.

Ensure that the installation complies with the provisions of ANSI/ESTA E1.58-2017. This standard gives important information on the temporary use of stage and studio lighting equipment outdoors that is supervised by qualified personnel while energized and inaccessible to the general public in the USA as referred to by NFPA 70 article 520.10. Touring shows in Canada must obtain a permit from the relevant authority before the first performance. Respect national and local regulations at all times.

The light source contained in this fixture must be replaced by Martin® Service or an authorized Martin Service partner only.



Install, operate and service Martin products only as directed in their user documentation, or you may create a safety hazard or cause damage that is not covered by product warranties.

Read this manual before installing, powering, operating or servicing the fixture. Follow the safety precautions and observe all warnings in this Safety and Installation Manual, in the fixture’s User Manual, and printed on the fixture.

The latest versions of this Safety and Installation Manual and the fixture's User Manual are available for download from the MAC Aura Raven XIP area of the Martin website at www.martin.com. Before you install, operate or service the fixture, check the Martin website and make sure that you have the latest user documentation for the fixture. Document revisions are indicated at the bottom of page 2.

Technical Support

If you have questions about how to install or operate the fixture safely, please contact Harman Professional Technical support:

- For technical support in North America, please contact
HProTechSupportUSA@harman.com
Phone: (844) 776-4899
- For technical support outside North America, please contact your national distributor.



Protection from electric shock

The fixture has an ingress protection rating of IP54 that is applicable in EN/IEC regions (Europe and other countries). It has a 'Wet locations' rating that is applicable in the USA and Canada. 'Wet Locations' include most outdoor areas without cover or protective shields, or some indoor areas exposed to water dripping or splashing.

An IP54 / 'Wet locations' rating means that a fixture can withstand rain, splashing water, condensation etc. but not high-pressure water jets. The fixture is designed to be used under any weather conditions, but it must not be exposed to an artificially high volume of water (in a fountain, waterfall or shower, for example). The most extreme rain ever recorded had a volume of 400 mm / 16 inches per hour. The fixture is designed to withstand such a condition. A fountain, waterfall or shower can create a much bigger volume of water (up to 15 000 mm / 50 feet per hour). The fixture is not designed to withstand conditions like these.

Do not immerse the fixture in water.

Shut down power to the fixture immediately if extreme conditions such as flooding arise.

Do not expose the fixture to high-pressure water jets.

The fixture is designed for temporary outdoor installation only. Installing it permanently in an outdoor location could cause accelerated aging that would potentially affect its IP54 rating. This would create a potential safety hazard and a risk of damage. Do not use the fixture for permanent outdoor lighting.

Do not install the fixture in locations where the air is aggressive to materials (where the air has a high salt or chlorine content, close to the sea or a swimming pool, for example).

Do not operate the fixture if the ambient temperature (T_a) falls below -10°C (14°F). Do not operate the fixture in ambient temperatures below 5°C (41°F) if ice is forming on the fixture. Protect the fixture from snow and ice. Freezing water may deform the fixture's housing, creating a safety hazard. Monitor weather conditions and take all appropriate safety precautions if a freezing hazard is forecast or present.

The fixture is rated IP54 / 'Wet locations' only when the following types of connector are used on cables connected to the fixture:

- Neutrik powerCON TRUE1 NAC3FX-W-TOP connector at the power IN socket,
- Neutrik powerCON TRUE1 NAC3MX-W-TOP connector at the power THRU socket,
- Neutrik TOP series 5-pin locking XLR connectors at the XLR (DMX, RDM) data sockets, and
- Neutrik TOP series etherCON connectors at the Ethernet (Art-Net, sACN, Martin P3) data sockets.

Use only these connector types and use only cables that are suitable for the given application with respect to humidity, water and sunlight resistance.

The power and data connectors are fitted with rubber caps to protect from water ingress. Keep rubber caps installed at all times on all connectors that are not in use.

The MAC Aura Raven XIP Beamshaper optional accessory from Martin is rated IP20. Installing the Beamshaper accessory on the front of the fixture reduces the fixture's IP rating from IP54 (fixture only) to IP20 (fixture with Beamshaper). When using the Beamshaper accessory, ensure that the fixture is installed only in an environment that is suitable for this lower IP20 rating.

Do not install the fixture with the connections panel facing upwards in locations that require an IP54 / 'Wet locations' rating.

Support the weight of cable runs. Do not allow a length of cable to hang from a connector.

Arrange cables so that they arrive at connectors from below. Create a 'drip loop' if necessary (see drawing on right). With this arrangement, gravity will cause any condensation or water droplets to run away from connectors.

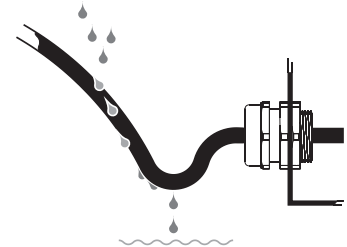

Drip loop

The fixture accepts AC mains power at 100-240 V~ (nominal), 50/60 Hz. Do not connect the fixture to mains power that is not within this range.

The fixture has a maximum total power consumption of 1120 W.

The fixture draws a maximum total current of:

- 11.3 A when connected to mains power at 100-120 V~
- 5.6 A when connected to mains power at 200-220 V~
- 4.8 A when connected to mains power at 230-240 V~

Do not connect a device – or an interconnected daisy chain of devices – to power if the maximum resulting current draw will exceed the electrical ratings of any cable or connector used to supply power.

Before connecting any devices to the fixture's power throughput socket, check the maximum current draw of all the devices that you will connect to power in a chain. Do not exceed a total of 16 amps maximum when you add together the current draw for the entire chain, including the first device in the chain.

If you relay power from one fixture to another using power throughput sockets, observe the following safety limits, or you may create a risk of fire and electric shock:

- Do not connect a MAC Aura Raven XIP fixture to the fixture's mains power thru/output socket when supplying the fixture with mains power from 100 V to 120 V. Do not connect any device that draws more than 4.7 A to the fixture's mains power thru/output socket when operating within this mains power voltage range.
- Do not connect more than two (2) MAC Aura Raven XIP fixtures in total to each other in an interconnected chain when supplying the fixture with mains power from 200 V to 220 V.
- Do not connect more than three (3) MAC Aura Raven XIP fixtures in total to each other in an interconnected chain when supplying the fixture with mains power from 230 V to 240 V.

The fixture draws a typical half-cycle RMS inrush current of 17.0 A for the first 10 milliseconds when mains power is first applied to the fixture at 230 V~, 50 Hz.

The voltage and frequency at the power throughput socket are the same as that applied at the power input socket.

To connect the fixture to mains power, you must first obtain 12 AWG or 2.5 mm² power input cable that is 16 A rated and temperature-rated to suit the installation environment. In the USA and Canada, the cable must be UL-listed, type SJTW or equivalent. In the EU, the cables must be type H05RN-F, H07RN-F or better. Suitable cables with the correct connectors are available from Martin.

Ensure that the fixture is electrically connected to ground (earth) via the power input cable. Do not remove the protective coating on the housing or loosen screws to establish a separate ground (earth) connection from the fixture's chassis.

Use only a source of mains power that complies with local building and electrical codes and has both overload and ground-fault (earth-fault) protection.

Socket outlets or external power switches used to supply the fixture with power must be located near the fixture and easily accessible so that the fixture can easily be disconnected from power.

Disconnect the fixture from AC mains power before carrying out any installation, cleaning or maintenance work and when the fixture is not in use.

Isolate the fixture from power immediately if the power plug or any seal, cover, cable, or other component is damaged, defective, deformed, showing signs of water ingress or showing signs of overheating. Do not reapply power until repairs have been completed.

Before using the fixture, check that all power distribution equipment and cables are in perfect condition and rated for the electrical requirements of all connected devices.

Do not remove any cover from the fixture except as described in the fixture's user documentation.

The fixture contains components that are accessible and live at high voltage while the fixture is connected to power and that remain under tension for up to five minutes after power is disconnected. Wait for at least five minutes after disconnecting from power before opening any of the fixture's covers.

Open covers and carry out service of internal components in a dry location and in dry conditions only.

The DMX and Ethernet transceivers of the fixture are isolated/SELV to prevent ground loops and for safety reasons.

Do not use this equipment at an altitude of more than 2000 m (6570 ft.) above sea level.



Protection from burns and fire

Do not operate the fixture if the ambient temperature (T_a) exceeds 40° C (104° F).

The exterior of the fixture becomes hot during use. After 5 minutes of operation a surface temperature of 80° C (176° F) shall be expected. The maximum steady state surface temperature is also 80° C (176° F). Avoid contact by persons and materials.

Allow the fixture to cool for at least 15 minutes before handling.

Keep flammable materials well away from the fixture. Keep all combustible materials (e.g. fabric, wood, paper) at least 0.2 m (8 in.) away from the fixture.

Ensure that there is free and unobstructed airflow around the fixture. Provide a minimum clearance of 0.5 m (1.7 ft.) around fans and air vents.

Do not use the fixture to illuminate surfaces within 2.5 m (8.2 ft.) of the fixture.

Do not stick filters, masks or other materials onto any optical component.

See drawing on right. The fixture's lenses can focus the sun's rays inside the fixture, creating a risk of fire and damage. Do not expose the front of the fixture to sunlight or any other source of powerful light from any angle, even for a few seconds. Make sure that the head will be pointing away from the sun and from any other potential source of powerful light at all times, even when the fixture is not in use.



Do not attempt to bypass thermostatic switches or fuses.



Protection from eye injury

This fixture corresponds to Risk Group 2 according to EN 62471 and IEC/TR 62778. It emits possibly hazardous optical radiation. It falls into the Risk Group categories shown below according to EN 62471 and IEC/TR 62778 under worst-case conditions:

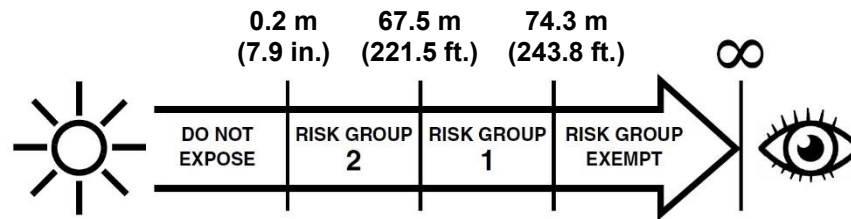

At a distance of less than 0.2 m (7.9 in.) from the fixture, the light output can potentially cause eye or skin injury before an exposed person's natural aversion responses (blink reflex and reaction to skin discomfort) can protect them. At distances greater than 0.2 m (7.9 in.), potential eye and skin injury hazards from the light output are normally prevented by natural aversion reflexes.

Position the fixture so that persons cannot be exposed to the fixture's light output at a distance of less than 0.2 m (7.9 in.) from the fixture and so that prolonged staring into the light output at less than 67.5 m (221.5 ft.) is not expected.

Do not look directly into the fixture's light output.

Do not look at the light output with magnifiers, telescopes, binoculars or similar optical instruments that may concentrate the light output.

Ensure that persons are not looking directly into the front of the fixture when the product lights up suddenly. This can happen when power is applied, when the product receives a control signal, or when certain control menu items are selected.

Disconnect the fixture from power at all times when the fixture is not in use.

Provide well-lit conditions to reduce the pupil diameter of anyone working on or near the fixture.



Protection from injury

The fixture weighs 28.8 kg (63.5 lbs.) not including rigging hardware.

When the fixture is in use, it must be either:

- fastened to a secure, stable structure such as a rigging truss, or
- standing on a stable horizontal surface where it will not present a danger of tripping or falling.

Install the fixture only as directed in this manual.

The fixture is not portable when installed.

Ensure that all supporting structures and hardware used can hold at least six (6) times the weight that they support (or more if required by locally applicable regulations).

Ensure that all rigging hardware items (rigging clamps, omega brackets etc.) are in perfect condition, are approved by a professional body such as TÜV for the weight that they will support, and that they comply with all locally applicable regulations.

Ensure that all supporting structures and rigging hardware items are suitable for the installation environment and will be safe under all weather and temperature conditions. Monitor weather conditions and take all appropriate safety precautions if a hazard is forecast or present.

If suspending from a rigging structure, fasten the fixture to a truss or similar support using two rigging clamps and omega brackets. Do not try to suspend the fixture from only one rigging clamp. Do not use safety cables as the primary means of support.

When clamping a fixture to a truss or other supporting structure in any orientation apart from hanging vertically with the head pointing downwards, use half-coupler-type rigging clamps. Do not use G-clamps, quick-trigger clamps or any other type of clamp that does not completely encircle the supporting structure when fastened.

If there is any danger that this product may cause injury or damage if the primary means of attachment fails, secure it as described in this user manual with a securely anchored safety cable that will catch it if it falls. Ensure that all safety cables used for secondary attachment are in perfect condition, are approved by a professional body such as TÜV for the weight that they will secure, and that they comply with all locally applicable regulations.

Remove as much slack as possible from the safety cable (by looping it more than once around the chord of a rigging truss, for example). Make sure that, if a primary means of attachment fails, the fixture cannot fall more than 20 cm (8 inches) maximum before the safety cable catches it.

If the safety cable attachment point becomes deformed, do not suspend the fixture. Have the fixture repaired by an authorized Martin service partner.

Allow enough clearance around the head to ensure that it cannot collide with an object or another fixture when it moves.

Check that all external covers and rigging hardware are securely fastened.

Block access below the work area and work from a stable platform whenever installing, servicing or moving the fixture. Make sure that there is no risk of injury from falling parts, tools or other materials.

Do not operate the fixture with missing or damaged covers, shields or any optical component.

Do not lift or carry the fixture by its head. Support the fixture by its base only.

In the event of an operating problem, stop using the fixture immediately and disconnect it from power. Do not attempt to use a fixture that is obviously damaged.

Do not modify the fixture in any way not described in the fixture's user documentation. Install only parts and accessories that are supplied by or approved by Martin for the fixture.

Refer any service operation not described in this manual to Martin Service or an authorized Martin service partner.

Introduction

Thank you for selecting the MAC Aura Raven XIP moving head lighting fixture from Martin®.

This Safety and Installation Manual is supplied with the fixture. It gives details of installing and servicing the fixture as well as connecting to mains power. The MAC Aura Raven XIP User Manual, containing full instructions for connecting to control data, setting up, controlling and monitoring the fixture is available for download from the MAC Aura Raven XIP area of the Martin website at www.martin.com. If you have any difficulty locating this document, please contact your Martin supplier for assistance.

Before installing, operating or servicing the MAC Aura Raven XIP, please check the fixture's area of the Martin website at www.martin.com and make sure that you have the latest user documentation for the product.

Not all product specifications are included in the fixture's user documentation. You can find full specifications for the fixture in the MAC Aura Raven XIP area of the Martin website. The online specifications include information to help you order accessories such as cables, flightcases etc.

The fixture is supplied with this Safety and Installation manual and two Martin omega brackets for fastening a rigging clamp to the fixture base.

Packing and unpacking

Allow the fixture to cool for 30 minutes before packing it for storage or transport in a flightcase or packaging. If the fixture is wet, wipe it with a soft, dry cloth and apply power until the fixture is completely dry before packing. This will avoid moisture damage and mold.

If you move the fixture from a cold to a warm environment, remove it from its flightcase or packaging and give it at least two hours to acclimatize before you apply power. This will help to avoid damage due to internal condensation.

Condensation

When using the fixture in outdoor locations – especially locations with wide temperature variations and/or high humidity – we recommend that you keep power applied to the fixture at all times in order to avoid condensation inside the fixture. However, it is possible to shut down power to the fixture for up to 18 hours if followed by a period of 6 hours with power applied.

Before using the product for the first time

1. Check the support pages on the Martin website at www.martin.com for the most recent user documentation and technical specifications for the fixture. Martin user manual revisions are identified by the revision letter at the bottom of the inside cover.
2. Read 'Safety information' on page 4 before installing, operating or servicing the fixture.
3. Unpack and ensure that there is no transportation damage before using the fixture. Do not attempt to operate a damaged fixture.
4. Check that the voltage and frequency of the local power source match the mains power requirements of the fixture.
5. Either hard-wire the fixture's power input cable to an AC mains power source or install as described in this manual a power plug (cord cap) that is suitable for local power outlets on the power input cable and connect the cable to an AC mains power outlet. If you need to fabricate a power cable, use only the cable and connector specified in this manual.

Applying mains power

The fixture does not have an on/off switch. It becomes active as soon as AC mains power is applied at the power input connector. Be prepared for the head to move and for the fixture to suddenly emit bright light.

Each time power is applied to the fixture, it will reset all effects and functions to their home positions. A reset typically takes around 35 seconds.

Cold starting

At +5° C (41° F) and below, the fixture starts up in cold-start mode. In this mode, the current to some motors is increased and reset speed is reduced. This makes sure that the fixture can reset safely without any step loss. After a successful reset, the fixture stays in cold-start mode until it has warmed up. In cold-start mode there is a slight increase in noise from the fixture. Some effects are slower than normal.

The fixture exits cold-start mode as soon as it reaches an internal temperature of approximately 20° C (68° F).

To warm up the fixture as quickly as possible, set LED output to full intensity.

Overview

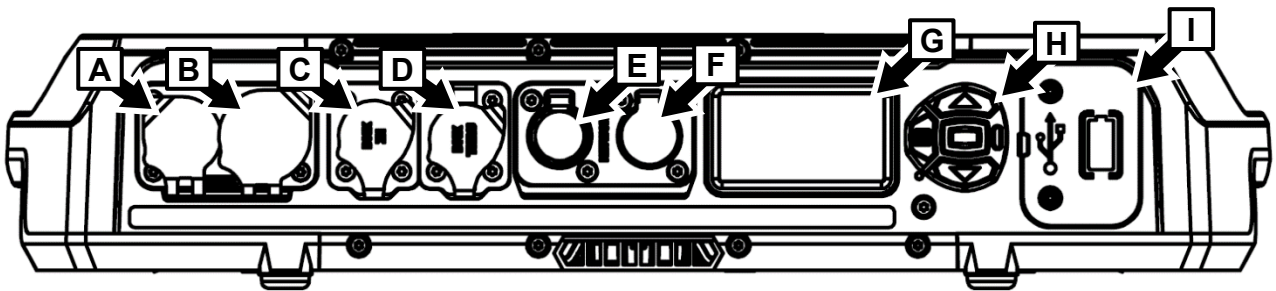

A – AC mains power IN (accepts Neutrik powerCON TRUE1 TOP or compatible)

B – AC mains power OUT/THRU (accepts Neutrik powerCON TRUE1 TOP or compatible)

C – DMX data IN (5-pin locking male XLR)

D – DMX data OUT/THRU (5-pin locking female XLR)

E – Control data Ethernet port A in/out

F – Control data Ethernet port B in/out

G – Control panel display (including antenna for NFC interface)

H – Control buttons

I – Cover for CR123A lithium battery and USB-C port (can be used with accessory options)

Tilt lock

The fixture has a tilt lock located on the yoke (see photo on right) that can be applied during servicing, for example.

It is not necessary to release the tilt lock before transporting the MAC Aura Raven XIP in its Martin flightcase, but the head must be vertical to match the flightcase insert.



Physical installation



Warning! Read ‘Safety information’ on page 4 before installing the fixture.

To avoid head collisions when installing MAC Aura Raven XIP fixtures next to each other, allow a minimum center-to-center distance between fixtures of 540 mm (21.3 inches).

Martin can supply installation hardware such as rigging clamps and safety cables that are suitable for use with the fixture (see the product specifications on the MAC Aura Raven XIP product page on the Martin website at www.martin.com).

Installation location

The MAC Aura Raven XIP is designed for permanent or temporary indoor use or for temporary outdoor use. A fixture with an IP54/‘Wet locations’ rating can withstand rain and splashing water, but it cannot withstand high pressure water jets or immersion in water.

Note that installing the Beamshaper optional accessory from Martin reduces the fixture’s IP rating to IP20. When using the Beamshaper accessory, ensure that the fixture is installed only in an environment that is suitable for this lower IP20 rating.

Fasten the fixture to a secure structure or surface or stand it on a surface where it cannot be moved or fall over. If you install the fixture in a location where it may cause injury or damage if it falls, secure it as directed in this manual using a securely anchored safety cable that will hold the fixture if the primary fastening method fails.

Installation environment

The fixture has a rugged construction and is designed to withstand temporary outdoor conditions. However, it is not designed for use in extreme environments such as air with a high content of salt, chlorine, acid or other aggressive agents. Exposure to harsh environmental conditions like these may result in deterioration of the product that is not covered by the product warranty. If the fixture is exposed to salt etc., rinse it carefully in pure water.

The fixture is designed and tested according to the IP54 standard. This means that the fixture is dust-protected, not dust-tight. Ingress of dust is not entirely prevented, but it shall not enter in sufficient quantity to interfere with the safe operation of the fixture. If the fixture is used in dusty or sandy environments, cleaning will be required after use.

Avoiding damage from other light sources

Do not point the light output from other lighting fixtures at the MAC Aura Raven XIP, as powerful light can damage the display.

Standing the fixture on a flat surface

The fixture can be placed on a hard, fixed, flat horizontal surface provided that there is no risk that it may cause an obstruction or be knocked over. Ensure that the surface can safely bear the weight of all items that it will support, including any dynamic loads.

If you install the fixture in a location where it may cause injury or damage if it falls, secure it as directed in this chapter with a securely anchored safety cable.

Mounting the fixture on a truss

The fixture can be clamped to a truss or similar rigging structure in any orientation. Use half-coupler type clamps (see illustration on right) that completely encircle the truss chord or tubular support.

If installing the fixture outdoors, mount it so that the connections panel does not face upwards. Ensure that cables arrive from below the fixture, creating 'drip loops' in cables if necessary. Check that all rigging hardware is suitable for outdoor use.

To clamp the fixture to a truss:

1. Check that the rigging structure can support at least six times (or more if required by local regulations) the weight of all fixtures and equipment to be installed on it.
2. Block access under the work area.
3. The fixture is supplied with two omega-type brackets. Bolt a half-coupler type rigging clamp that is in perfect condition and approved for the weight that it will support securely to the each bracket. Use M12, grade 8.8 steel minimum bolts with self-locking nuts.
4. Fasten the two omega brackets complete with rigging clamps to the base of the fixture by locking each bracket's quarter-turn fasteners into two of the receptacles (see **B** in illustration below) in the base of the fixture. The brackets must be spaced evenly. Turn quarter-turn fasteners a full 90° to lock them as shown on right.



Half-coupler clamp

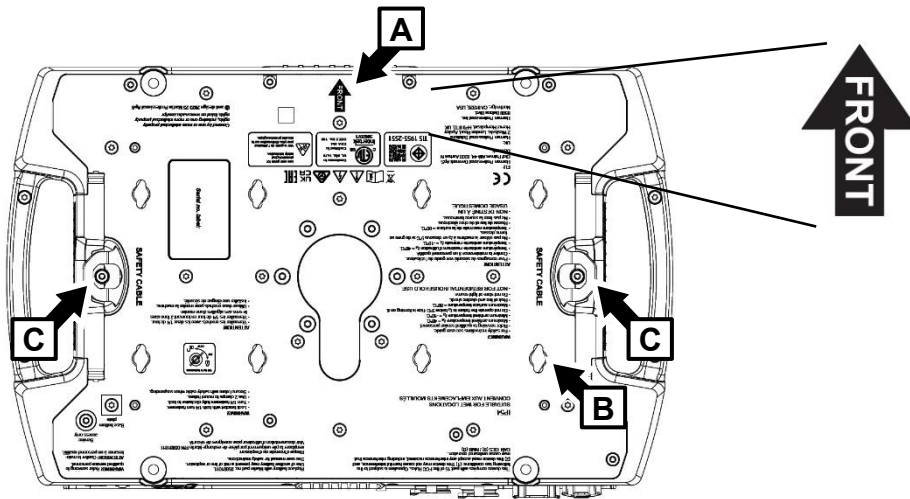
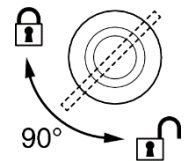

5. Note the position of the arrow marked **FRONT** (see **A** in illustration above). Working from a stable platform, hang the fixture on the truss and fasten the two rigging clamps onto the truss with **FRONT** pointing towards the main area to be illuminated.
6. Secure the fixture with a safety cable as directed below.
7. Make sure that there is no possibility of the head colliding with other fixtures or objects when it moves through its full pan and tilt ranges.

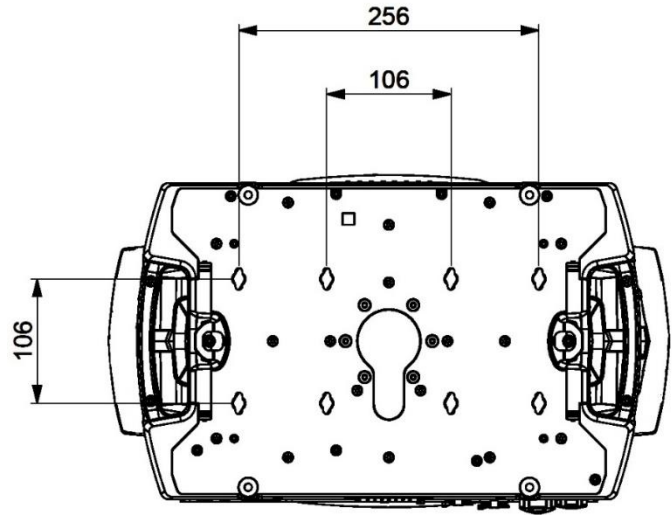

Quarter-turn receptacles in base

Securing with a safety cable

1. Obtain a safety cable that is approved for the weight of the fixture.
2. Fasten the cable to one of the safety cable attachment points in the base of the fixture (see **C** in illustration above) by either looping it around or fastening a carabiner clip to the attachment point. Do not use one of the fixture's carrying handles as the attachment point for the safety cable.
3. Remove as much slack as possible from the safety cable (by looping the cable around the truss chord, for example) and fasten it to a secure anchoring point.
4. Make sure that the safety cable will hold the fixture if a primary attachment fails.

AC mains power



Warning! Read ‘Safety information’ on page 4 before connecting the fixture to AC mains power.

The fixture has an auto-ranging power supply that accepts AC mains power at 100-240 V at 50/60 Hz. Do not apply AC mains power at any other voltage or frequency to the fixture.



The fixture's maximum current draw is as follows:

- At 100-120 V~: 11.3 A
- At 200-220 V~: 5.6 A
- At 230-240 V~: 4.8 A

Typical half-cycle RMS inrush current: 17.0 A at 230 V, 50 Hz.

Typical earth-leakage current: 0.7 mA.

The fixture requires a power input cable with an IP65-rated Neutrik powerCON TRUE1 NAC3FX-W (TOP) or equivalent female cable connector for AC mains power input. The cable must meet the requirements listed under “Protection from electric shock” on page 5. Martin can supply suitable input cables 1.5 m (4.9 ft.) long with connectors installed, as well as loose input connectors (see the Martin website at www.martin.com).

The fixture can be hard-wired to a building electrical installation if you want to install it permanently. Alternatively, you can connect it to local power outlets if you install a suitable power plug on the power input cable. When installing a power plug, follow the plug manufacturer's instructions and connect the wires in the power cable following the color coding guide in the table below:

	Live or L	Neutral or N	Earth, Ground or ⊕
US system	Black	White	Green
EU system	Brown	Blue	Yellow/green

If you need to install a Neutrik powerCON TRUE1 (TOP) or equivalent IP65-rated connector on a power cable, follow the connector manufacturer's instructions (normally published on the manufacturer's website or included with the product), respecting the color coding guide above.

Linking MAC Aura Raven XIP fixtures to power in a chain at 100-120 V

If you are supplying the fixture with AC mains power at 100-120 V, do not connect any other MAC Aura Raven XIP fixture to the mains power OUT/THRU socket on the fixture's connections panel. Do not connect any device to the mains power OUT/THRU that draws a current of more than 4.7 A.

Linking MAC Aura Raven XIP fixtures to power in a chain at 200-240 V

You can connect up to two (2) fixtures in total to mains power at 200-220 V and three (3) fixtures in total to mains power at 230-240 V in a linked daisy chain as follows:

1. Obtain a 12 AWG / 2.5 mm² power input cable and 12 AWG / 2.5 mm² power relay cables (available from Martin – see the Martin website at www.martin.com).
2. Relay mains power from one fixture to another by connecting fixtures to power in a linked daisy-chain, mains power OUT/THRU socket to mains power IN socket. This daisy-chain may contain up to a maximum of two (2) fixtures in total at 200~220V or three (3) fixtures in total at 230V~240V.

If you are supplying a fixture with AC mains power at 200-240 V, do not connect any device – or chain of devices – that draws a current of more than 10.4 A to the mains power OUT/THRU socket of that first fixture.

If you connect two or three fixtures to power in a daisy-chain, we recommend that you draw power from a circuit that is protected by a type C MCB (Miniature Circuit Breaker). This will avoid the breaker tripping unnecessarily due to inrush current.

Connecting to power

Connect the fixture to AC mains power by lining up the keys in the IP65 power input cable connector with the keyways in the mains power IN connector in the connections panel, inserting the connector and twisting clockwise. Twist the cable connector counterclockwise and remove it from the connections panel to disconnect.

The mains power connectors support hot-plugging, but it is still good practice to shut down power to the power input cable before connecting to or disconnecting from the fixture if you can do this without inconvenience.

The fixture does not have an on/off switch. It becomes active as soon as power is applied at the power input connector. Be prepared for the head to move suddenly and for the fixture to emit bright light as soon as power is applied.

Data connections

See the MAC Aura Raven XIP User Manual available for download from www.martin.com for full details of connecting the fixture to control data.

Use shielded twisted-pair Ethernet cable of type S/UTP, SF/UTP, S/STP or SF/STP only for the data link. The cable must be rated Cat 5e or better. The cable shield must be electrically connected to connector housings, and the other devices on the data link must also support shielded connections.

Service and maintenance



Warning! Read 'Safety information' on page 4 before servicing the fixture.

Refer any service or repair operation not described in this manual or in the fixture's User Manual to an authorized Martin service technician. Do not try to carry out such an operation yourself, as doing so may present a health or safety risk. It may also cause damage or malfunction, and it may void your product warranty. The LED light source is not user-replaceable.

Installation, on-site service and maintenance can be provided worldwide by the Martin Professional Global Service organization and its approved agents, giving owners access to Martin's expertise and product knowledge in a partnership that will ensure the highest level of performance throughout the product's lifetime. Please contact your Martin supplier for details.

The user must clean the MAC Aura Raven XIP periodically to maintain optimum performance and cooling, removing air filters from the base as described in this chapter for inspection and cleaning. The user may replace the fixture's 3-volt lithium battery as described in this chapter. The user may upload firmware (fixture software) via the fixture's DMX data input port, Ethernet port or USB-C port using firmware from Martin and instructions in the fixture's User Manual (available for download from the Martin website at www.martin.com). Finally, the user may install or uninstall an optional wireless DMX accessory that fits onto the fixture's USB port following instructions from Martin. All other service operations on the fixture must be carried out by Martin, its approved service agents or trained and qualified personnel using the official Martin service documentation for the fixture.

It is Martin policy to apply the strictest possible calibration procedures and use the best quality materials available to ensure optimum performance and the longest possible component lifetimes. However, optical components are subject to wear and tear over the life of the product, resulting in gradual changes in color over many thousands of hours of use. The extent of wear and tear depends heavily on operating conditions and environment, so it is impossible to specify precisely whether and to what extent performance will be affected. However, you may eventually need to replace optical components if their characteristics are affected by wear and tear after an extended period of use and if you require fixtures to perform within very precise optical and color parameters.

Service mode

Pressing MENU and ENTER buttons immediately when the fixture name appears in the display while powering the fixture on puts the fixture into service mode, in which pan and tilt motors are deactivated and SERV appears in the display. To take the fixture out of service mode, power off and then power on again normally.

The MAC Aura Raven XIP User Guide (available for download from the MAC Aura Raven XIP page on www.martin.com) gives full details of the menus in the fixture's control panel.

Cleaning

Important! Excessive dust, smoke fluid, and particle buildup degrades performance, causes overheating and will damage the fixture. Damage caused by inadequate cleaning or maintenance is not covered by the product warranty.

At regular intervals, the front glass must be cleaned to optimize light output and air filters must be removed for inspection and cleaning. Cleaning schedules for lighting fixtures vary greatly depending on the operating environment. It is therefore impossible to specify precise cleaning intervals for the fixture. Environmental factors that may result in a need for frequent cleaning include:

- Use of smoke or fog machines.
- High airflow rates (near air conditioning vents, for example).
- Presence of cigarette smoke.
- Airborne dust (from stage effects, building structures and fittings or the natural environment at outdoor events, for example).

If one or more of these factors is present, inspect fixtures within their first 100 hours of operation to see whether cleaning is necessary. Check again at frequent intervals. This procedure will allow you to assess

cleaning requirements in your particular situation. If in doubt, consult your Martin dealer about a suitable maintenance schedule.

Use gentle pressure only when cleaning, and work in a clean, well-lit area. Do not use any product that contains solvents or abrasives, as these can cause surface damage.

To clean the fixture:

1. Disconnect the fixture from power and allow it to cool for at least 15 minutes.
2. Vacuum or gently blow away dust and loose particles from the outside of the fixture and air vents with low-pressure compressed air. Holding cooling fan blades stationary with a screwdriver will protect them from spinning too fast and possibly being damaged when you apply a vacuum or air jet.
3. Clean surfaces using warm water with a little detergent and a soft cloth, sponge or soft brush of the type used for washing cars. Do not rub glass surfaces hard: lift particles off with a soft repeated press. Dry with a soft, clean, lint-free cloth or low-pressure compressed air. Remove stuck particles with an unscented tissue or cotton swab moistened with glass cleaner or distilled water.
4. Wipe the fixture with a soft, dry cloth after cleaning. We recommend that you apply power to the fixture for a short time, which will allow it to warm up slightly and dry out completely, before putting it into storage.

Cleaning air filters

The MAC Aura Raven XIP has two wire gauze air filters in the base of the fixture.

Base air filters

To service the base air filters:

1. See photos below. For each of the two air filters, push on the air filter cover retaining clips (arrowed) to release them, then remove the filter from the base.

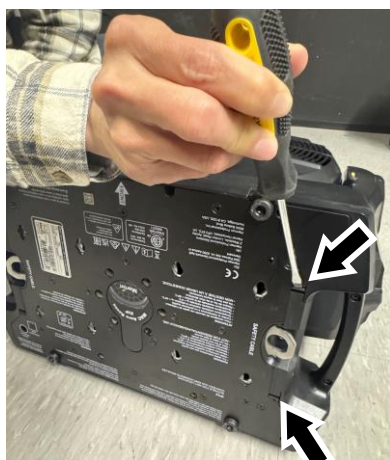

2. Remove dust from each filter with a soft brush and/or low-pressure compressed air. Remove grease with warm soapy water. You can clean the filters in a household dishwasher at maximum 50° C (122° F), short cycle recommended.
3. Dry each filter carefully, then push it back into its recess in the base until both retaining clips lock into place. Make sure that the filter is held securely.

Battery replacement

Warning! Disconnect the fixture from AC power before replacing its battery. Do not attempt to recharge the battery, or you may create a risk of fire or explosion.

The MAC Aura Raven XIP has a non-rechargeable 3-volt lithium battery that provides power to the control panel and display when the fixture is not connected to AC mains power. If the battery runs flat, you must replace it. Do not attempt to recharge it.

The battery is located behind a cover in the USB port / battery compartment next to the control panel on the base of the fixture. If a wireless DMX module accessory is installed, the battery is behind this module.

To replace the battery:

1. Order Martin P/N 05801011 (CR123A, 3 V lithium battery).
2. Disconnect the fixture from AC mains power and allow to cool.
3. See illustration on right. Remove the two Torx10 screws from their holes (arrowed) in the black USB port / battery compartment cover.



4. Carefully lever the cover off the fixture base with a flathead screwdriver. Take care not to damage seals.

5. See illustration on right. The battery is located behind a yellow rubber cover. Pull the yellow cover off the battery compartment and remove the used battery.



6. Insert the new CR123A battery, respecting the correct battery polarity (positive terminal facing upwards, towards the head).

7. Reinstall the yellow rubber cover over the battery compartment. Check the condition of the seal on the black cover (or the wireless DMX module, if used) that fits over the USB port / battery compartment. The seal must be in perfect condition. If not, contact your Martin supplier for a replacement. Install the cover (or module), fastening it in position with its two screws. Check that it is closed securely before reapplying power.

8. Dispose of the used battery responsibly: send to an authorized waste recycling and disposal center.

Lubrication

The MAC Aura Raven XIP does not require lubrication under normal circumstances. Moving parts can be checked and a long-lasting Teflon-based grease reapplied by a Martin service partner if necessary.

Specifications and compliance

For full product specifications, see the MAC Aura Raven XIP area of the Martin website at www.martin.com

FCC compliance

This equipment has been tested and found to comply with the limits for a Class B digital device, pursuant to part 15 of the FCC Rules. These limits are designed to provide reasonable protection against harmful interference in a residential installation. This equipment generates, uses and can radiate radio frequency energy and, if not installed and used in accordance with the instructions, may cause harmful interference to radio communications. However, there is no guarantee that interference will not occur in a particular installation. If this equipment does cause harmful interference to radio or television reception, which can be determined by turning the equipment off and on, the user is encouraged to try to correct the interference by one or more of the following measures:

- Reorient or relocate the receiving antenna.
- Increase the separation between the equipment and receiver.
- Connect the equipment into an outlet on a circuit different from that to which the receiver is connected.
- Consult the dealer or an experienced radio/TV technician for help.

FCC supplier's declaration of conformity declaration

This device complies with part 15 of the FCC Rules. Operation is subject to the following two conditions:

- This device may not cause harmful interference.
- This device must accept any interference received, including interference that may cause undesired operation.

Canadian Interference-Causing Equipment Regulations – Règlement sur le Matériel Brouilleur du Canada

This Class B digital apparatus meets all requirements of the Canadian Interference-Causing Equipment Regulations. *Cet appareil numérique de la classe B respecte toutes les exigences du Règlement sur le Matériel Brouilleur du Canada.*

CAN ICES (B) / NMB (B)

EU Declaration of Conformity

Harman Professional, Inc. hereby declares that the equipment type MAC Aura Raven XIP complies with the following: European Union Restriction of Hazardous Substances Recast (RoHS2) Directive 2011/65/EU and as amended by 2015/863; European Radio Equipment Directive (RED) 2014/53/EU.

Type: NFC tag

Frequency: 13.56 MHz

The full text of the EU Declaration of Conformity covering this product is available for download from the MAC Aura Raven XIP product area of the Martin website at www.martin.com.

Conditional connection

For conformity with mains voltage fluctuations and flicker according to EN61000-3-11 during extensive use of continuous strobe effects, the user must determine – in consultation with the mains power supply authority if necessary – that the equipment is connected to a supply impedance of less than 0.39 ohms at 50 Hz.

Disposing of this product



Martin products are supplied in compliance with Directive 2012/19/EC of the European Parliament and of the Council of the European Union on WEEE (Waste Electrical and Electronic Equipment), where applicable.

Help preserve the environment! Ensure that this product is recycled at the end of its life. Your supplier can give details of local arrangements for the disposal of Martin products

