

iK81 User Guide



Important safety instructions

- Please read these instructions and keep them for future reference.
- Heed all warnings and follow all instructions.
- Keep this unit away from rain or moisture.
- Keep this unit away from heat sources.
- Keep this unit away from candles and flames.
- Don't block the ventilation openings.
- Install in accordance with Martin Audio instructions.
- Don't remove the protective earth from the power cable plug. This unit must be earthed.
- Protect the power cable from being walked on or damaged, particularly near the plugs.
- Unplug this unit during lightning storms or when unused for a long period of time.
- Don't open this unit. There is a risk of electric shock and there are no user-serviceable parts.
- If servicing is required, contact qualified service personnel.
- At the end of this unit's life, please use a recycling centre.

Table of Contents

Introduction	6
Key features	6
Other iKONS	6
Drive modules	6
LIR crossover filtering	7
FIR linear phase equalisation	7
Quick start	8
Auto and static IP	8
Connecting the amplifier and PC	8
Installation	8
Audio connections	8
Front panel	9
Back panel	11
Example system setup	12
To load XE300 bi-amp presets	12
Operation	13
Starting up the unit	13
Modules, preset components and snapshots	13
Home screen	13
Drive modules	13
Drive module presets	14
Component presets	14
Factory module presets	14
Storing module presets	14
Recalling module presets	14
Snapshots	15
Secure mode	15
Revert to factory default settings	15
Dante	16
Dante support by iK81	16
Updating inputs	17
Selecting the input channel	17
Input gain, polarity and muting	17
Recall preset	17
Store preset	18
Routing	18
Routing style	18
Input and fallover type	19
Trim digital input gain	20
Drive module latency	20
Input FIR	20
FIR high shelf EQ	21
Input parametric EQ filters	21
FIR low shelf EQ	21
High pass filter	22
Input delay	22
Updating outputs	23
Selecting the output channel	23
Output gain and polarity	23

Recall preset	23
Drive load	23
Output routing	24
Limiters	24
Output VX limiter	24
Output thermal limiter	25
Output excursion limiter	25
Bridge mode	25
Output FIR	26
Output high shelf filter	26
Output parametric EQ filters	26
Output low shelf filter	27
Output low pass filter	27
Output high pass filter	27
Output delay	28
Updating utilities	29
DevID	29
Stereo linking	29
Dante name	29
Firmware version	29
Power saving	30
External breaker protection	31
Alarm	31
AUX style	32
Parametric EQ bandwidth	32
Screen contrast	32
Recall snapshot	32
Store snapshot	32
Static IP address	33
IP mode	33
Current IP address	33
Ethernet	35
Ethernet configurations	35
DHCP	35
Auto IP	35
Static IP	35
IP Troubleshooting	35
Vu-Net software	36
To download Vu-Net	36
Using Vu-Net	36
To download the Vu-Net User Guide	36
Performance logging	36
Installation	37
AC power connection	38
Audio connections	39
Input connections	39
Analogue audio connection	39
Output connections,	39
Load matching	40
Rack ears	41
Requirements	41

To attach the amplifier brackets	41
To attach the rack brackets	42
To attach the amplifier brackets to the rack strip	42
AUX port	43
Example	43
AUX styles	43
Event or state	43
Q-SYS plugin	45
To download the Q-SYS plugin	45
To download the Q-SYS plugin user guide	45
Tipi control	46
Tipi specification	46
Tipi message format	46
Commands	46
Responses	47
Error codes	47
Fault codes	47
Incident codes	48
Tipi testing	49
To test Tipi using Tera Term	49
Example commands	49
Example responses	49
Tipi commands	50
Latency delay	52
Input latency	52
Output latency	52
Processing latency	52
Example latency calculation	52
Protection systems	53
Summary of protection indication	53
Fault relay port	53
Signal path	54
EQ and filter response graphs	55
Power draw and thermal dissipation	59
Technical specifications	60
Protection systems	61
iK81 loudspeaker compatibility	62
Amplifier compatibility legend	63

Introduction

The Martin Audio iK81 advanced system amplifier represents current state-of-the-art technology in a number of areas. This product is the result of several years of research, from which many advances in switched mode power technologies and ever finer detail in signal processing have stemmed. Taking advantage of the latest advances in analogue to digital conversion technologies, the unit achieves performance levels among the very best that current technology permits.

Key features

- Eight channels of sonically pure Class D amplification
- Very high power density in 2U rack space
- Up to 10,000 watts total power output, depending on load impedance
- Packed with robust protection and monitoring systems to keep the show going
- External Breaker Protection (EBP) limits the current draw to prevent breakers opening
- Martin Audio minimal signal path design
- Class leading sonic performance achieved by the use of state-of-the-art amplifier technologies and highly advanced DSP algorithms using Linea Micro Detail (LMD)
- High performance 96 kHz DSP on all inputs and outputs
- Up to 1,000 FIR filter taps at 48 kHz on each output channel (reserved for optimised systems)
- High speed Ethernet communications supporting DHCP, static IP and auto IP and direct connection to a computer without the need for a router or a switch
- Powerful Drive Module concept, abstraction from device centric to speaker-based control
- Innovative Component Presets to allow individual outputs to be used for selected drivers of a loudspeaker system
- Unique VX limiter providing dynamic control for passive two-way enclosures
- Unique LIR crossover shapes giving FIR-like performance without the drawbacks
- Linear phase HF system EQ profiling which provides perfect integration between enclosures

- Innovative excursion control limiter with sliding High Pass Filter; limits only the damaging low frequencies
- Transducer thermal modelling provides regulation limiters, addressing long term overload
- Overshoot limiter governs amplitude of transient signals retaining average power whilst constraining peak energy
- Analogue, AES3 and Dante (AES67 compatible) inputs
- Automatic fallover from digital inputs

Other iKONs

There are three amplifiers in the iKON range and the only differences are total power output and number of channels:

iKON	Channels	Power ¹
iK42	4	20,000 watts
iK81	8	10,000 watts
iK41	4	6,000 watts

¹The total power output depends on the load impedance

For details of the other iKON amplifiers, go to our website martin-audio.com.

Drive modules

The iK81 processor uses Drive Modules to order and group channels using a speaker-based approach to controlling, designing and recalling speaker configurations. A Drive Module is the processing provided by one input DSP block and a number of output DSP blocks. These blocks are associated by routing. For example, if input DSP block B is routed to outputs 3 and 4, then this is a two-way Drive Module with input DSP block B forming the 'Master' control, and output DSP blocks 3 and 4 providing the driver-related control. Overall, this forms the processing typically for one loudspeaker sub-system. You can use [Vu-Net \(page 36\)](#) to control and monitor the associated speaker.

The presets in the device are Drive-Module centric and are used to configure individual Drive Modules rather than the whole device. Importantly, Drive Modules move the focus away from the processing device and onto the loudspeaker systems. A Drive Module preset can be broken into components, allowing any output to be used

for any component within a Drive Module preset (that is, any driver in a loudspeaker sub-system).

For further details, see [Modules, preset components and snapshots \(page 13\)](#).

LIR crossover filtering

This device includes Linear Impulse Response (LIR) crossover filtering, which results in a linear phase crossover that has a constant delay regardless of frequency. This is unlike other types of crossover that delay different frequencies to different extents, thus smearing the arrival times. The LIR crossover can thus be described as having a flat group delay response and is thus entirely free of group delay distortion. The shape of the LIR crossover filter is quite similar to a 4th order or 24 dB/Oct Linkwitz-Riley filter and maintains zero phase difference between the adjacent bands across the crossover region to keep the polar response rock steady.

FIR linear phase equalisation

The input high shelf equalisers use finite impulse response (FIR) filtering to produce linear phase equalisation; that is, all frequencies are delayed by the same amount, perfectly preserving the transient response. This can also be important in applications where different amounts of EQ are applied to different parts of a speaker cluster, such as to add 'Throw' EQ boost so that parts of cluster that are throwing further can have HF absorption correction added. If this EQ is not linear phase, then the zones where the speakers combine may suffer frequency response anomalies. Linear phase equalisation solves this problem.

Quick start

This user guide tells you how to set up and configure your amplifier using the front panel. Note that most people connect the amplifier to a PC using Ethernet and set up and control the amplifier using [Vu-Net \(page 36\)](#) at the PC. In this case, you can use the front panel as a fall back when you don't have a PC available.

The only important setting where you have to use the front panel is IP mode (auto or static). You can't change this using Vu-Net.

Auto and static IP

If you only have a few iKON amplifiers, it is probably easiest and best to use auto IP.

If you have several iKON amplifiers, we recommend that you use static IP. This will allow you to create offline project files in [Vu-Net \(page 36\)](#) that target the static IP address. It will also make troubleshooting much easier.

- To choose the IP mode, see [IP mode \(page 33\)](#).
- To update the static IP address, see [Static IP address \(page 33\)](#),

For further details, see [Ethernet \(page 35\)](#).

Connecting the amplifier and PC

If you have several iKON amplifiers to control from a PC, you will need to connect them using an Ethernet network.

If you only have one iKON amplifier, you can either use an Ethernet network or connect it directly to the PC without a network. For a direct connection, you run a single network cable between the amplifier's Ethernet socket and the PC's Ethernet socket.

If you have a small number of amplifiers and no network available, you can connect and configure them one at a time using a direct connection.

Installation

For details, see [Installation \(page 37\)](#).

Audio connections

For details, see [Audio connections \(page 39\)](#).

Front panel

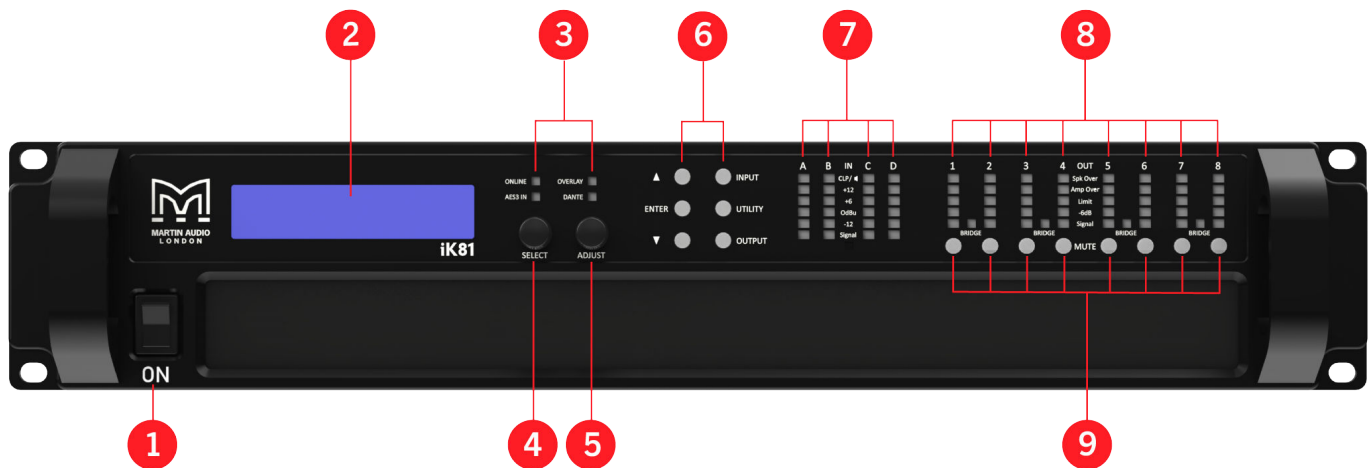

1. **Power switch.** The mains power on-off switch is at bottom front left. If the device is in [sleep mode \(page 30\)](#), you can wake it up using [Vu-Net \(page 36\)](#) or by switching this power switch off, waiting for a couple of seconds and then switching it on again.

2. **Graphical display.** The home screen shows the device name and an overview of the channel allocation. It may also show a flashing IP address. For details, see [Home screen \(page 13\)](#).

If **SECURE** appears (either top right or bottom left), this means that the amplifier is in [secure mode \(page 15\)](#) and you won't be able to edit any settings.

When you select the [input \(page 17\)](#), [output \(page 23\)](#) or [utility \(page 29\)](#) menus, the menu item names appear on the top line and the parameters to edit appear on lower lines.

To change the contrast, see [Screen contrast \(page 32\)](#).

3. **Status Indicators.** The **ONLINE** indicator has three states:
 - **Off** – The unit isn't connected to [Vu-Net \(page 36\)](#).
 - **Flashing** – The unit is configured to [auto IP \(page 33\)](#) and is searching for an IP address. If the unit fails to find one, it will assign itself an IP address automatically and the indicator will stop flashing.

- **On** – The unit is connected to [Vu-Net \(page 36\)](#).

The **AES3 IN** indicator is on when one or more inputs are configured to an AES3 source.

The **DANTE** indicator is on when one or more inputs are configured to Dante.

The **OVERLAY** indicator is unused, so you can ignore this.

4. **SELECT** (the left-hand dial) allows you to switch between parameters.
5. **ADJUST** (the right-hand dial) allows you to edit parameters.



When you edit a parameter, the parameter changes straight away. There is no separate step to save changes.

6. **Menu buttons.** When you press **INPUT**, **OUTPUT** or **UTILITY**, the button illuminates to show that you've selected this menu. The up ▲ and down ▼ buttons illuminate to show that you can use these buttons to page through the menu. The **ENTER** button illuminates whenever you need to press the **ENTER** button to confirm a change.

The **OUTPUT** button displays a menu of parameters associated with each [output channel \(page 23\)](#).

The **INPUT** button displays a menu of parameters

associated with [each input socket or each input DSP channel \(page 17\)](#). If you press **INPUT** or **OUTPUT** several times, you scroll through the input or output channels. After the last channel, you exit the menu and return to the home screen. The **UTILITY** button displays [miscellaneous parameters \(page 29\)](#). The menus are mutually exclusive – if you press one of these buttons you switch to that menu. To exit from a menu, press **UTILITY**.



To lock the front panel (to stop tampering), see [Secure mode \(page 15\)](#).

7. **Input Signal Indicators.** A set of five indicators show **Signal**, **-12**, **0dBu**, **+6** and **+12** and **CLP/(mute)** for each of the DSP inputs A, B, C and D. The **Signal** indicator shows the signal is greater than about -40 dBu. The **CLP/(mute)** indicator warns you of input overload and operates at 1 dB before clip. This indicator also shows whether the [input is muted \(page 17\)](#).
8. **Limiter Indicators.** The output indicators show the status of the limiter and the output level. The level shown is the level before the limiter, referenced to the limiter threshold.

The **Signal** indicator shows when a signal is present on the output.

The **-6dB** indicator shows that the signal has reached 6 dB below the limiter threshold.

The **Limit** indicator shows that the threshold of that output channel has been reached.

Bridge Indicator. This illuminates when the channel pair is in [Bridge mode \(page 25\)](#). The amplifier uses the settings for the left channel of the pair.

Amplifier Indicator. This indicates when the amplifier protection systems are reducing the gain to keep the parameters of the amplifier within specification, or when the channel is clipping.

Driver Indicator. This indicates a signal 6 dB higher than the limiter threshold, or that the threshold of the excursion limiter has been exceeded, or that the thermal limiter is active. Please note that because of the long release time of the thermal limiter, this indicator may remain illuminated for several seconds after signal on that channel is reduced.
9. **Mute Buttons.** DSP output mute status is indicated and controlled by an illuminated button for each channel. If the amplifier protection systems automatically mute a channel, the mute button flashes.

Back panel

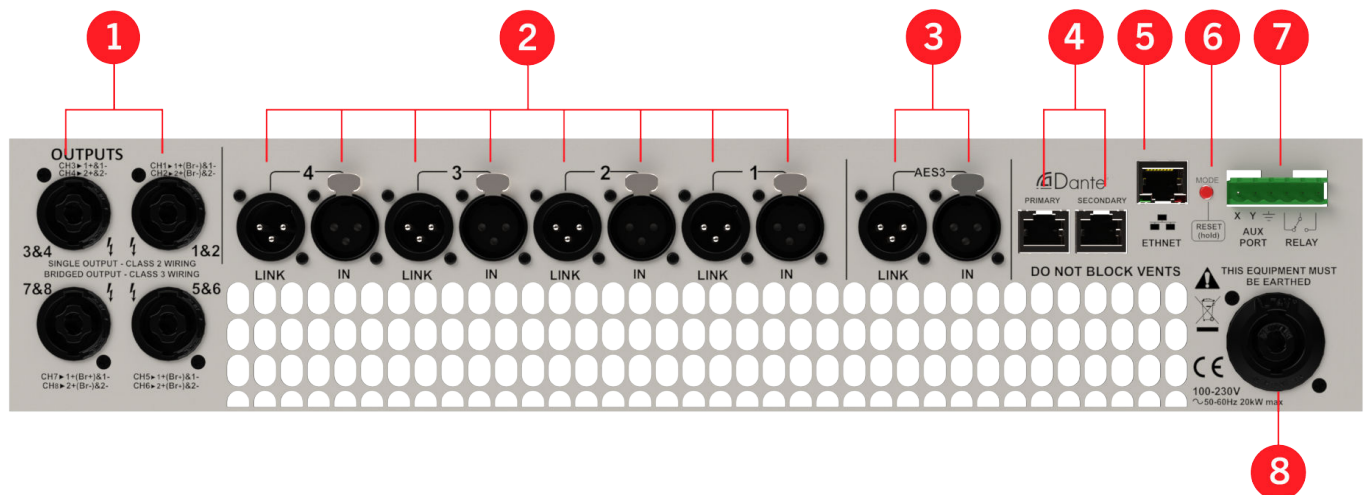

- Loudspeaker connectors.** The amplifier has four speakON outputs labelled 1&2, 3&4, 5&6 and 7&8. For details, see [Output connections, \(page 39\)](#).
- Analogue audio input connectors.** All audio connections are fully balanced and wired: pin 1 to ground (as required by the AES48 standard), pin 2 hot and pin 3 cold. For details, see [Audio connections \(page 39\)](#).
Analogue audio link connectors. Carries a duplicate (parallel) connection (to another amplifier for example).
- AES3 audio input connectors.** For inputting digital audio signals. The Input is fully balanced and wired: pin 1 to ground, pin 2 data+ and pin 3 data. The link connector allows a buffered AES3 signal to be passed on to another device.
- Dante ports.** Primary and Secondary [Dante ports \(page 16\)](#).
- Ethernet port.** Use this port to connect your amplifier and PC so that you can control the amplifier using [Vu-Net \(page 36\)](#). This software also allows you to update the amplifier firmware and to integrate with other Martin Audio products such as MLA and CDD-Live.
- Mode.** If you press and hold this button for about six seconds, the unit changes the IP mode to auto and searches for an IP address. If the IP mode is already auto, it just searches for an IP address. In both cases, if the amplifier fails to find an IP address, it allocates one. You can also [change IP mode using the utility menu \(page 33\)](#).
- Six-pin Phoenix connector** (also known as a Euroblock). This has two ports:
 - The three pins on the left are the [AUX port \(page 43\)](#). This allows you to control the amplifier from an external device.
 - The three pins on the right are the [Fault relay port \(page 53\)](#). This allows you to monitor the amplifier from an external device.
- Power Inlet.** Connect to a suitable mains electricity supply using an earthed 32 amp powerCON connection power lead. To allow you to choose the appropriate cable length, cable type and plug type, we supply the powerCON connector but not the cable. The device has a switch-mode power supply that is capable of operating with a nominal mains voltage of 100 V to 230 V, 50/60 Hz without reconfiguration. For details, see [AC power connection \(page 38\)](#).



The device must be earthed to a suitable power earth. Failure to do so will invalidate the warranty and could be hazardous. It could also affect performance and operation.

Example system setup

The iK81 is not only a powerful amplifier but it has extremely comprehensive processing abilities allowing complex systems to be designed to suit any application. However, often all you need to do is recall the appropriate preset and connect your speakers and source. As an example, this section shows you how to set up a system using an iK81 and XE300 stage monitors.

To load XE300 bi-amp presets

1. Connect an analogue, AES3 or [Dante \(page 16\)](#) input feed to the amplifier.

If you are using two XE300 bi-amp monitors, connect one to amplifier speakON output 1&2 and the other to output 3&4. For these bi-amp monitors, output socket 1&2 pins 2+/2- carry channel 2 and output socket 3&4 pins 2+/2- carry channel 4. For further details, see [Audio connections \(page 39\)](#).

2. Power up the amplifier.
3. Press **INPUT** so that **A** appears top left. This shows that you are editing input channel A. Press the down arrow button **▼** once so that **RECL** (for Recall Preset) appears top left.
4. Rotate **ADJUST** (the right-hand dial) so that **XE300 BI** appears bottom right.
5. Press **ENTER**. The following message will appear and the **ENTER** button flashes to show that this is the button to press:

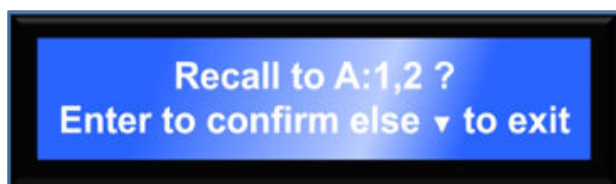

6. Press **ENTER** to confirm. Input A now feeds output 1 with XE300 LF parameters and output 2 with XE300 HF parameters.
7. Press **INPUT** so that **B** appears top left. Note that when you switch from one input to the next, the amplifier shows the same menu item, in this case **RECL**.

8. Rotate **ADJUST** (the right-hand dial) to select the **XE300 BI** preset and press **ENTER**.

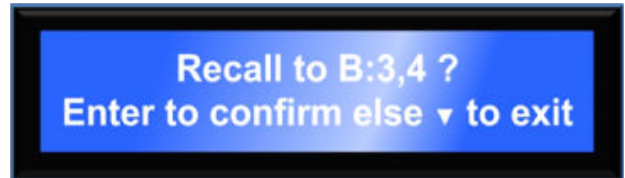

9. Press **ENTER** to confirm. Input B now feeds output 3 with XE300 LF parameters and output 4 with XE300 HF parameters.
10. Preset loading is now complete and you can press **UTILITY** to escape.

The home screen shows that:

- DSP A is loaded with the preset for one monitor and is routed to outputs 1 and 2.
- DSP B is loaded with the preset for the other monitor and is routed to outputs 3 and 4.
- DSP C and D aren't used and therefore aren't routed anywhere.

The amplifier is ready for use.

Operation

Starting up the unit

The power switch is on the front of the unit at the lower left. When you switch on the amplifier, it goes through a start-up cycle and checks all the sub-systems. The screen shows you progress and when complete, the home screen shows the drive module configuration.

Modules, preset components and snapshots

A Drive Module represents a loudspeaker sub-system (for example, a sub and full range) and comprises one input channel routed to a number of output channels. The size of the Drive Module is determined by the number of outputs it includes. The amplifier can contain up to four Drive Modules.

DSP input A	Output 1
	Output 2

A Module Preset is a collection of settings (parameters) for a Drive Module of a particular size. The Preset contains a set of parameters for one input and a set of parameters for each of the outputs in the module. The most obvious example would be a bi-amp system, either individual cabinets such as a BlacklineX sub used with one of the full range cabinets, or a bi-amp speaker such as the XE500 monitor.

When you recall a Module Preset, it will automatically change the routing between Input DSPs and Outputs, consuming a number of outputs according to the size of the Drive Module. Recalling a Module Preset thus always creates a Drive Module with consecutive outputs.

Input component parameters	Output component parameters
	Output component parameters

A Component is a collection of settings (parameters) for one channel (input or output). Any one of the output components in a Module Preset may be recalled to any individual output.

A Snapshot is a device-wide representation of most of the settings in the device. This is represented as four Input Component numbers, four Output Component numbers, plus a number of machine-centric settings such as routing and input/output analogue/digital selection and so on.

Device settings	Input A component number	Output 1 component number
	Input B component number	Output 2 component number
	Input C component number	Output 3 component number
	Input D component number	Output 4 component number

Home screen



The home screen shows an overview of the configuration of the device:

- The device name is shown at top left.
 - To update the device name, use [Vu-Net \(page 36\)](#). You can't change the device name at the amplifier [front panel \(page 9\)](#).
- If an IP address is shown flashing at top right, this means that the amplifier is configured to use [static IP \(page 33\)](#) and isn't connected to [Vu-Net \(page 36\)](#).
 - To update the static IP address, see [Static IP address \(page 33\)](#).
- If **SECURE** is shown top right, this means that the amplifier is connected to [Vu-Net \(page 36\)](#) or is in [secure mode \(page 15\)](#).
- The four [Drive modules \(page 6\)](#) are shown on the middle line. This shows the input DSP channel (A, B, C and D) and the name you've given each channel.
 - To update the channel names, use [Vu-Net \(page 36\)](#). You can't change the channel names at the amplifier [front panel \(page 9\)](#).
- The bottom line shows the physical input number and a list of the outputs that are routed from the drive module.

Drive modules

The iKON amplifiers use drive modules to represent loudspeaker sub-systems. Drive modules result in a less

processor-centric and more speaker-orientated system design. A drive module is defined as the processing provided by one Input DSP and a number of outputs, which are associated with one-another by means of routing. For example, if Input DSP B is routed to outputs 3 and 4, then this is a two-way drive module; input DSP B forming the 'master' control, and output DSP 3 and 4 providing the driver-related control. The input DSP parameters control the drive module (and thus the speaker sub-system). You can control and monitor sub-systems using [Vu-Net \(page 36\)](#).

Drive module presets

Presets do not change the settings device-wide. Rather, recalling a Module Preset creates a Drive Module by 'consuming' a number of consecutive outputs and setting up routing between the Input the preset was recalled on and those outputs. The parameters in that Drive Module are then set according to the parameters in the components in the Module Preset.

You can if you wish create modules with non-consecutive outputs by manually manipulating the routing and then recalling Component Presets to the individual outputs. You could then store the resulting system in a Snapshot, though you wouldn't be able to store the Module in a Module Preset.



When a Module Preset Recall consumes outputs to construct a module, it treats a pair of Bridged outputs as a single channel, so recalling a two-way Module Preset will consume three output channels if a Bridged pair is encountered. For further details, see [Bridge mode \(page 25\)](#).



DSP inputs are not the same as physical inputs. The iK81 has four audio inputs and four DSP inputs. This is a matrix mixing system where any physical inputs, be they analogue, AES3 or Dante, can drive any number of DSP inputs.

Component presets

A Component Preset represents the processing for just one output. Any part of a Module Preset can be recalled to any one output. A Drive Module comprised of parameters which have been recalled to its outputs using Component Preset Recalls can then be saved into another Module Preset provided the outputs remain consecutive (i.e. you have not changed the routing manually). If you have changed the routing manually, you can save the whole arrangement into a Snapshot. For further details, see [Modules, preset components and snapshots \(page 13\)](#).

Factory module presets

The amplifier contains a small library of factory presets designed to suit a range of enclosures. However, [Vu-Net \(page 36\)](#) has an extensive library of presets, so it's best to install presets using [Vu-Net \(page 36\)](#).

Factory presets may contain some parameters that are fixed and hidden from view and other parameters that you can edit. The number and type of hidden parameters is dependent on the factory preset. Typically, the settings that are a function of the loudspeaker cabinet design are hidden. Factory presets are locked (as indicated by a 'box' symbol after the preset name), which means you can't overwrite them. However, you can create and update your own presets.

Storing module presets

For details of how to store drive modules, see [Store preset \(page 18\)](#).



You can only store drive module presets where the outputs are consecutive.



If you store a drive module preset at the [front panel \(page 9\)](#), you won't be able to edit the component names. To change component names, you need to save the module preset using [Vu-Net \(page 36\)](#).

Recalling module presets

For details, see [Recall preset \(page 17\)](#).

Snapshots

You can recall snapshots using:

- [Vu-Net software \(page 36\)](#)
- The amplifier front panel with [RECL in the utility menu \(page 32\)](#)
- Signals sent to the [AUX port \(page 43\)](#) on the back of the amplifier
- [TIPI commands \(page 50\)](#) or the [Q-SYS plugin \(page 45\)](#)

When you recall a snapshot, the amplifier recalls components to each input and output and it may change device-wide settings, effectively recalling a processor-wide preset.

The parameters inside the drive modules are not individually stored in snapshots. Recalling a snapshot triggers the recall of the appropriate input and output components, rather than restoring the parameters that were active when the snapshot was stored. This has the distinct advantage that the library of OEM presets can be updated without having to be concerned about what parameters might have been saved in snapshots. It does however require that any existing edits to the parameters in drive modules are stored into drive module presets before you store the snapshot.

For further details, see [Modules, preset components and snapshots \(page 13\)](#).

Secure mode

Secure mode (front panel lock) stops people from updating settings at the front panel. If you connect the amplifier to [Vu-Net \(page 36\)](#), the amplifier automatically switches to secure mode.

If you're not using [Vu-Net \(page 36\)](#), you can manually switch secure mode on and off at the front panel as described below.

Note that in secure mode you can still:

- Mute and unmute output channels.
- View but not edit the [input \(page 17\)](#), [output \(page 23\)](#) and [utility settings \(page 29\)](#).

In secure mode, all indicators operate normally, and the Ethernet port is unaffected.

To switch secure mode on or off

- Press and hold the **UTILITY** button for about 8 seconds.



When you're connected to [Vu-Net \(page 36\)](#), you can't switch off secure mode.

Revert to factory default settings

If you wish to restart with the amplifier in a clean state, you can erase all settings and revert to the factory defaults. Note that you can't do this if the amplifier is in [secure mode \(page 15\)](#).

To revert to factory default settings



This deletes all settings, so only do this if you're sure it's the right thing to do.

1. Simultaneously press and hold the up arrow button ▲ and the mute output 1 button for about 8 seconds.
2. Press **ENTER** to confirm or press the down arrow button ▼ to cancel.

Dante

Currently, all iKON amplifiers include Dante support (AES67 compatible). However, we have previously produced non-Dante versions of these amplifiers. If you have a non-Dante version, please ignore the Dante sections of this user guide.

If you are not sure whether your amplifier has Dante or not, check the Dante ports on the [back panel \(page 11\)](#); if they are blanked off, you have a non-Dante model.

Upgrading an iKON from non-Dante to Dante is a chargeable service and you will need to return your amplifier to your supplier for the installation of the Dante card. For further details, contact your supplier.

Dante support by iK81

The iK81 supports eight channels of Dante, four routable to input DSP and four routable to output DSP.

- To see this diagrammatically, see [Signal path \(page 54\)](#).
- To set this up, use [Vu-Net \(page 36\)](#).

To set up eight channels of Dante

1. Start [Vu-Net \(page 36\)](#).
2. From a project, double click on an iK81 icon.
3. Click on the **Routing** tab at the bottom of the screen.
4. Click the **Dante** selection button on the middle left.

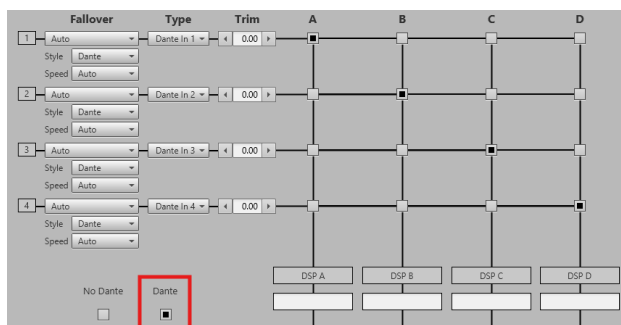

5. In the **Type** fields at top left, select **Dante in 1**, **Dante in 2** and so on.

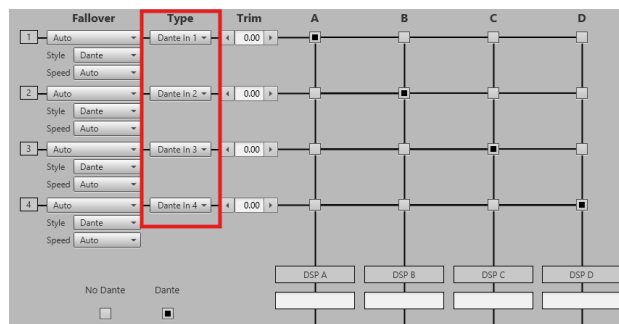

6. Set up the **Fallover** settings ([page 19](#)) as necessary.

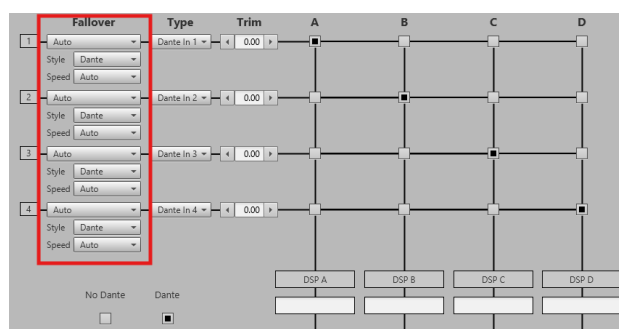

7. At top right, choose the input routing for A, B, C and D.

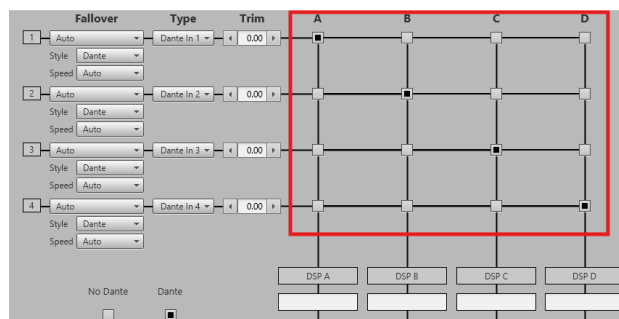

8. At bottom right, choose the output routing for **Dante in 5**, **Dante in 6** and so on.

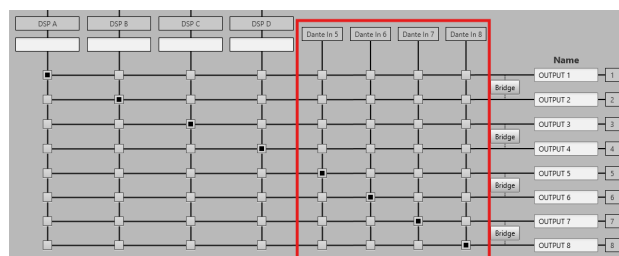

Updating inputs

The input menu allows you to choose:

- **GAIN** – see [Input gain, polarity and muting \(page 17\)](#)
- **RECL** – see [Recall preset \(page 17\)](#)
- **STOR** – see [Store preset \(page 18\)](#)
- **IN Input** – see [Routing \(page 18\)](#)
- **IN Style** – see [Routing style \(page 18\)](#)
- **TYPE** – see [Input and fallover type \(page 19\)](#)
- **TRIM** – see [Trim digital input gain \(page 20\)](#)
- **Latency** – see [Drive module latency \(page 20\)](#)
- **FIR** – see [FIR high shelf EQ \(page 21\)](#)
- **EQ1 to EQ6** – see [Input parametric EQ filters \(page 21\)](#)
- **EQa and EQb** – see [FIR low shelf EQ \(page 21\)](#)
- **HPF** – see [High pass filter \(page 22\)](#)
- **DEL** – see [Input delay \(page 22\)](#)

Selecting the input channel

Press **INPUT** to select the input menu. The letter at top left shows the channel that you're editing and this could be any of the input channels: A, B, C or D. For example:

1. Press **INPUT** several times until channel D appears top left.
2. Press **UTILITY** to exit the menu.
3. Press **INPUT** and you go back to channel D.

If you use **INPUT** to scroll through the channels, the first channel is always A:

1. Press **INPUT** several times until channel D appears top left.
2. Press **INPUT** rather than **UTILITY** to exit the menu.
3. Press **INPUT** and you go back to channel A.

Note that when you select an input menu item and change to another channel, you remain on the same menu item. For example:

1. Press **INPUT** so that channel A appears top left.
2. Press the down arrow button ▼ until **RECL** appears top left (normally one press).

3. Press **INPUT**. You are now on menu item **RECL** for channel B.
4. Press **INPUT** three times to exit the menu.
5. Press **INPUT** again and you go back to channel A and menu item **RECL**.

Input gain, polarity and muting

Use the input **GAIN** menu item to update the input channel gain, polarity and muting.

To update gain, polarity and muting

1. Press **INPUT** to select the channel. For details, see [Selecting the input channel \(page 17\)](#).
2. **GAIN** should appear top left. If not, press the down arrow button ▼ several times until it does.
3. Rotate **ADJUST** (the right-hand dial) to choose the gain (–40 to 20 dB in 0.2 increments).
4. Rotate **SELECT** (the left-hand dial) to choose **Pol** for polarity and rotate **ADJUST** (the right-hand dial) to choose **Norm** to use normal polarity or **Rev** to use reverse polarity.
5. Rotate **SELECT** (the left-hand dial) to choose **Mute** and rotate **ADJUST** (the right-hand dial) to select **Norm** to unmute or **Mute** to mute this input channel.
6. Press **UTILITY** to exit the menu or press **INPUT** several times to step through the channels.

Recall preset

Use the input **RECL** menu item to recall input presets. The factory-installed presets have a square next to the preset number. You can also create your own input presets using [Store preset \(page 18\)](#) and these presets won't have a square next to them.

Note that the amplifier also has [output presets \(page 23\)](#).

To recall a preset

1. Press **INPUT** to select the channel. For details, see [Selecting the input channel \(page 17\)](#).
2. Press the down arrow button ▼ several times until **RECL** appears top left (usually one press).

3. Rotate **ADJUST** (the right-hand dial) to choose the preset.
4. Press **ENTER** to recall this preset.
5. Press **ENTER** to confirm or press the down arrow button ▼ to cancel.
6. Press **UTILITY** to exit the menu or press **INPUT** several times to step through the channels.

Store preset

Use the input **STOR** menu item to store input presets. To recall presets, see [Recall preset \(page 17\)](#).

Note that the amplifier also has [output presets \(page 23\)](#).

To store a preset

1. Press **INPUT** to select the channel. For details, see [Selecting the input channel \(page 17\)](#).
2. Press the down arrow button ▼ several times until **STOR** appears top left (usually two presses).
3. Rotate **ADJUST** (the right-hand dial) to choose preset number (1 to 50).
4. Press **ENTER** to choose this preset number.
5. You can now enter a name for the preset, by rotating **ADJUST** (the right-hand dial) to select each character and rotating **SELECT** (the left-hand dial) to select the position in the name.
6. Press **ENTER** to choose this name.
7. Press **ENTER** to confirm or press the down arrow button ▼ to cancel.
8. Press **UTILITY** to exit the menu or press **INPUT** several times to step through the channels.

Routing

Use the **IN** menu item to set up routing.

Routing allows you to route any physical analogue or digital signal channel to any DSP input. This is effectively a matrix mixing system where all DSPs can be driven from any one input or from any two, three or four inputs. Summed inputs have 6dB of attenuation so that a sum of largely similar programme material remains at the correct calibrated level.

To set up routing

1. Press **INPUT** to select the channel. For details, see [Selecting the input channel \(page 17\)](#).
2. Press the down arrow button ▼ several times until **IN** appears top left (usually three presses).
3. Rotate **ADJUST** (the right-hand dial) to choose the routing for this channel. This can be 1, 2, 1+2, 3, 4, 3+4, 1+3, 1+4, 2+3, 2+4, 123, 1234, 124, 134, 234.
4. Press **UTILITY** to exit the menu or press **INPUT** several times to step through the channels.

Routing style

Use the **IN Style** menu item to check that the routing style is set to **Combo** and not **Matrix**. Matrix routing isn't supported and isn't available in [Vu-Net \(page 36\)](#). If you set the routing style to **Matrix**, it will cause inconsistent routing when synchronising between hardware and software in [Vu-Net \(page 36\)](#).

If you have used **System Engineer** (for example, to download log files), use this front panel menu item to confirm that the routing style is still set to **Combo**.



Routing style can only be checked and edited at the front panel. You can't view or change the routing style in [Vu-Net \(page 36\)](#).

To set routing style

1. Press **INPUT** to select the channel. For details, see [Selecting the input channel \(page 17\)](#).



Make sure you select channel A. You can only set routing style when the channel is A.

2. Press the down arrow button ▼ several times until **IN** appears top left and **STYLE** appears top right (usually four presses).
3. Rotate **ADJUST** (the right-hand dial) to choose the routing style **Combo** and not **Matrix**.



Make sure the routing style is set to **Combo**.

- Press **UTILITY** to exit the menu or press **INPUT** several times to step through the channels.

Input and fallover type

The **TYPE** menu item allows you to select which input type to use for the channel (analogue, AES3 or Dante) and to specify what the amplifier should do if digital input fails or is inactive.

Detect and speed

The **TYPE Detect** screen (added in firmware 1.680) has two settings, **Detect** on the left and **Speed** on the right. This screen allows you to specify how fallover works for digital input.

The **Detect** setting only applies to Dante:

- **Audio** – Fallover as soon as Dante audio stops even if the Dante network is still responding.
- **Dante** – Fallover only if Dante fails (Dante stops responding or has synchronisation problems).

The **Speed** setting only applies to digital input (Dante or AES3). For Dante, what counts as failure depends on the **Detect** setting (see above):

- **Auto** – Fallover as soon as digital input fails and fallback to it automatically as soon as it returns.
- **Delayed** – Fallover as soon as digital input fails and if it returns, switch back to it automatically after five minutes.
- **Latch** – Fallover as soon as a digital input fails but don't switch back to it automatically. If you want to switch back, you will need to do so manually using the next screen or [Vu-Net \(page 36\)](#).

Fallover

The **TYPE Fallover** screen allows you to specify the **Fallover** type on the left of the screen:

- **Manual** – No automatic fallover. The amplifier uses the input type you specify on the right of the screen under the heading **Type** (see the next section).
- **Dante>AES3** – Use Dante and if this fails automatically switch to AES3.

This option is only available for channels A and B as channels C and D don't support AES3.

- **Dante>Analog** – Use Dante and if this fails automatically switch to analogue.

This option is only available for channels A and B. To select the same option for channels C and D, use **Auto**.

- **AES3>Analog** – Use AES3 and if this fails automatically switch to analogue.

This option is only available for channels A and B as channels C and D don't support AES3.

- **Auto** – For channels A and B, use Dante and if this fails, use AES3 and if this fails, use analogue. For channels C and D, use Dante and if this fails use analogue. This setting means that you can just plug in Dante, AES3 or analogue and the amplifier will adapt to the signal.

Type

If you select a **Fallover** type of **Manual**, you need to specify the input type under the heading **Type** on the right of the screen:

- For channels A and B, you can choose Dante, AES3 or analogue.
- For channels C and D, you can only choose Dante or analogue, as these channels don't support AES3.

If you select a **Fallover** type of anything other than **Manual**, the current input type is shown under the heading **Type** on the right of the screen. You can't edit this input type as the amplifier selects the type automatically.

For example, if **Fallover** is **Dante>AES3** the type on the right will be Dante unless Dante fails, in which case the type on the right will automatically change to AES3.

The only exception is if **Speed** is set to **Latch** (see above). In this case, if the digital input fails you can switch back to this input manually using the **Type** setting on the right of the screen.

To change the input and fallover type

- Press **INPUT** to select the channel. For details, see [Selecting the input channel \(page 17\)](#).
- Press the down arrow button ▼ several times until **TYPE** appears top left (usually five presses).
- If you are using firmware 1.680 or above and you are using digital input and an automatic fallover type:

Rotate **ADJUST** (the right-hand dial) to choose **Detect** (see explanation above).

Rotate **SELECT** (the left-hand dial) to choose **Speed** and rotate **ADJUST** (the right-hand dial) to select **Auto**, **Delayed** or **Latch** (see explanation above).

Press the down arrow button ▼ once to go to the second **TYPE** screen.

4. Rotate **ADJUST** (the right-hand dial) to choose **Fallover** (see explanation above).
5. If the fallover type is **Manual**, rotate **SELECT** (the left-hand dial) to choose **Type** and rotate **ADJUST** (the right-hand dial) to choose the input type (see explanation above).
6. Press **UTILITY** to exit the menu or press **INPUT** several times to step through the channels.

Trim digital input gain

This amplifier can use analogue inputs, AES3 digital inputs or [Dante digital inputs \(page 16\)](#). The **TRIM** menu item allows you update digital input gain.

AES inputs

When you [assign a DSP input channel to AES3 \(page 19\)](#), the **AES3** indicator illuminates.

There is no standard for the relative gains between analogue and AES3 inputs so depending on the levels delivered by the audio sources, you may need to adjust the digital input gain trims to normalise them. For example:

- To achieve 0dBFS = +18dBu, set the AES3 trim to –2dB.
- To achieve 0dBFS = +24dBu, set the AES3 trim to +4dB.

This device will automatically lock onto any sample rate within the range 28kHz and 108kHz.

Dante Inputs

Using [Dante input \(page 16\)](#), you can select any channel or channels as being sourced from this network. To do this, connect the audio network to the connection on the [back panel \(page 11\)](#) and set the relevant [Input channels to Dante \(page 19\)](#).

When you select Dante as part of the input routing, the **Dante** indicator illuminates (it does this even if there are no cables plugged into the Dante ports).

As with the AES3 inputs, you can set the relative gain between analogue input and audio sourced from Dante.

The amplifier will automatically select the correct sample rate from the incoming stream.

For other details on the operation of Dante, please refer to the relevant manufacturer's documentation.

To trim digital input gain

1. Press **INPUT** to select the channel. For details, see [Selecting the input channel \(page 17\)](#).
2. Press the down arrow button ▼ several times until **TRIM** appears top left (usually seven presses).
3. Rotate **ADJUST** (the right-hand dial) to choose the AES3 gain (–40 to 20 dB in 0.2 increments).
4. Rotate **SELECT** (the left-hand dial) to choose **Dante** and rotate **ADJUST** (the right-hand dial) to choose the Dante gain (–40 to 20 dB in 0.2 increments).
5. Press **UTILITY** to exit the menu or press **INPUT** several times to step through the channels.

Drive module latency

Use the **Latency** menu item to see the current [Latency delay \(page 52\)](#).

To see the latency

1. Press **INPUT** to select the channel. For details, see [Selecting the input channel \(page 17\)](#).
2. Press the down arrow button ▼ several times until **Latency** appears top left (usually eight presses).



The latency shown on the front panel doesn't include the [input and output latencies \(page 52\)](#).

3. Press **UTILITY** to exit the menu or press **INPUT** several times to step through the channels.

Input FIR

For input FIR, there are nine stages of equalisation available for each channel:

- Three shelving filters. These are the [high shelf filter \(page 21\)](#) and the [two low shelf filters \(page 21\)](#).

- [Six parametric filters \(page 21\)](#).

You can also apply a [high pass filter \(page 22\)](#).

FIR high shelf EQ

Use the **FIR** menu item to update frequency and gain for the FIR high shelf EQ. For details of FIR, see [input FIR \(page 20\)](#).

The input high shelf EQ is implemented using a Finite Impulse Response (FIR) filter and exhibits a linear phase response; that is all frequencies are delayed by the same amount. This can be important in applications where different amounts of EQ are applied to different parts of a speaker cluster, such as to add 'Throw' EQ boost so that parts of cluster that are throwing further can have HF absorption correction added. If this EQ isn't linear phase, then the zones where the speakers combine may suffer frequency response anomalies. Being a linear phase FIR equaliser, this necessarily introduces some [latency delay \(page 52\)](#), which is constant regardless of the settings.

If you switch off the FIR high shelf EQ (by setting the **Enable** parameter to **Off**) it's removed from the signal path entirely and no longer adds any latency.

To update the FIR high shelf EQ

1. Press **INPUT** to select the channel. For details, see [Selecting the input channel \(page 17\)](#).
2. Press the down arrow button ▼ several times until **FIR** appears top left (usually nine presses).
3. Rotate **ADJUST** (the right-hand dial) to choose the frequency.
4. Rotate **SELECT** (the left-hand dial) to choose **Enable** and rotate **ADJUST** (the right-hand dial) to select **On** or **Off**.
5. Rotate **SELECT** (the left-hand dial) to choose **Gain** and rotate **ADJUST** (the right-hand dial) to change the cut and boost in 0.2 dB increments.
6. Press **UTILITY** to exit the menu or press **INPUT** several times to step through the channels.

Input parametric EQ filters

For each of the six input parametric EQ filters you can specify the frequency, bandwidth and gain. For details of FIR, see [input FIR \(page 20\)](#).

Note that the amplifier also has [output parametric EQ filters \(page 26\)](#).

To update the six parametric filters

1. Press **INPUT** to select the channel. For details, see [Selecting the input channel \(page 17\)](#).
2. Press the up arrow button ▲ several times until **EQ1** appears top left (usually five presses).
3. Rotate **ADJUST** (the right-hand dial) to choose the frequency.
4. Rotate **SELECT** (the left-hand dial) to choose **Width** and rotate **ADJUST** (the right-hand dial) to update the bandwidth in [Q or octaves \(page 32\)](#).
5. Rotate **SELECT** (the left-hand dial) to choose **Gain** and rotate **ADJUST** (the right-hand dial) to update the gain (0.2 dB increments).
6. Press the up arrow button ▲ again so that **EQ2** appears top left. Update the second parametric filter and repeat for all six parametric filters.
7. Press **UTILITY** to exit the menu or press **INPUT** several times to step through the channels.

FIR low shelf EQ

Use the **EQa** and **EQb** menu items to update frequency, slope and gain for the two low shelf EQ filters. For details of FIR, see [input FIR \(page 20\)](#).

Note that in [Vu-Net \(page 36\)](#):

- **EQa** is **LS1** (low shelf one).
- **EQb** is **LS2** (low shelf two).

To update the FIR low shelf EQ

1. Press **INPUT** to select the channel. For details, see [Selecting the input channel \(page 17\)](#).
2. Press the up arrow button ▲ several times until **EQa** appears top left (usually three presses). This is low shelf one.
3. Rotate **ADJUST** (the right-hand dial) to update the frequency.
4. Rotate **SELECT** (the left-hand dial) to choose **Slope** and rotate **ADJUST** (the right-hand dial) to update the slope in dB. This is shown as Q in [Vu-Net \(page 36\)](#).
5. Rotate **SELECT** (the left-hand dial) to choose **Gain** and rotate **ADJUST** (the right-hand dial) to change the cut and boost in 0.2 dB increments.

- Press the up arrow button ▲ until **EQb** appears top left. This is low shelf two. Edit this in the same way as low shelf one.
- Press **UTILITY** to exit the menu or press **INPUT** several times to step through the channels.
- Rotate **ADJUST** (the right-hand dial) to change the delay in ms. To remove the delay, set the delay to 0 ms.
- Press **UTILITY** to exit the menu or press **INPUT** several times to step through the channels.

High pass filter

Use the **HPF** menu item to edit the high pass filter for the input signal. You can update the frequency and select the following filter types:

1st	Not supported in Vu-Net (page 36)
Bes12	Bessel 12 dB
But12	Butterworth 12 dB
LR12	Linkwitz-Riley 12 dB
Bes18	Bessel 18 dB
But18	Butterworth 18 dB
Bes24	Bessel 24 dB
But24	Butterworth 24 dB
LR24	Linkwitz-Riley 24 dB
Har4th	Hardman 4th order – Not supported in Vu-Net (page 36)

To select the high pass filter

- Press **INPUT** to select the channel. For details, see [Selecting the input channel \(page 17\)](#).
- Press the up arrow button ▲ several times until **HPF** appears top left (usually two presses).
- Rotate **ADJUST** (the right-hand dial) to choose the frequency. If you want to switch off the high pass filter, rotate to the left to set the frequency to <<Out.
- Rotate **SELECT** (the left-hand dial) to choose **Shape** and rotate **ADJUST** (the right-hand dial) to choose the high pass filter type (see above).
- Press **UTILITY** to exit the menu or press **INPUT** several times to step through the channels.

Input delay

Use the **DEL** menu item to add a delay to an input channel. See also [Latency delay \(page 52\)](#).

To update input delay

- Press **INPUT** to select the channel. For details, see [Selecting the input channel \(page 17\)](#).
- Press the up arrow button ▲ several times until **DEL** appears top left (usually one press).

Updating outputs

The output menu allows you to choose:

- **GAIN** – see [Output gain and polarity \(page 23\)](#)
- **RECL** – see [Recall preset \(page 23\)](#)
- **DRIV** – see [Drive load \(page 23\)](#)
- **ROUT** – see [Output routing \(page 24\)](#)
- **LIM** – see [Output VX limiter \(page 24\)](#)
- **Tmax** – see [Output thermal limiter \(page 25\)](#)
- **Xmax** – see [Output excursion limiter \(page 25\)](#)
- **AMP** – see [Bridge mode \(page 25\)](#)
- **EQ<** – see [Output high shelf filter \(page 26\)](#)
- **EQ1 to EQ8** – see [Output parametric EQ filters \(page 26\)](#)
- **EQ>** – see [Output low shelf filter \(page 27\)](#)
- **LPF** – see [Output low pass filter \(page 27\)](#)
- **HPF** – see [Output high pass filter \(page 27\)](#)
- **DEL** – see [Output delay \(page 28\)](#)

Selecting the output channel

Press **OUTPUT** to select the output menu. The number at top left shows the channel that you are editing and this could be any of the output channels: 1, 2, 3, 4, 5, 6, 7 or 8.

Selecting output channels works in the same way as selecting input channels; for details, see [Selecting the input channel \(page 17\)](#). The only difference is that input channels have letters (A, B, C and D) and output channels have numbers.

Output gain and polarity

Use the **GAIN** menu item to adjust the output channel gain and polarity.

To update gain and polarity

1. Press **OUTPUT** to select the channel. For details, see [Selecting the output channel \(page 23\)](#).
2. **GAIN** usually appears top left. If not, press the down arrow button ▼ several times until it does.
3. Rotate **ADJUST** (the right-hand dial) to choose the gain (–40 to 20 dB in 0.2 increments).

4. Rotate **SELECT** (the left-hand dial) to choose **Pol** and rotate **ADJUST** (the right-hand dial) to choose **Rev** for reverse polarity or **Norm** for normal polarity.
5. Press **UTILITY** to exit the menu or press **OUTPUT** several times to step through the channels.

Recall preset

Use the output **RECL** menu item to recall a preset to an output channel. The **Comp** parameter shows a component number with the following format:

ModulePreset.ComponentNumber

For example, 3.2 is module preset 3 and component number 2.

The preset name is shown to the right.

Note that the amplifier also has [input presets \(page 17\)](#).

To recall a preset

1. Press **OUTPUT** to select the channel. For details, see [Selecting the output channel \(page 23\)](#).
2. Press the down arrow button ▼ several times until **RECL** appears top left (usually one press).
3. Rotate **ADJUST** (the right-hand dial) to select a preset.
4. Press **ENTER** to recall this preset.
5. Press **ENTER** to confirm or press the down arrow button ▼ to cancel.
6. Press **UTILITY** to exit the menu or press **OUTPUT** several times to step through the channels.

Drive load

Use the **DRIV** menu item to adjust the optimal drive level for a given driver impedance. The screen also shows the live measured impedance value under the heading **Imp** on the right. If there is insufficient signal level to measure the impedance, it displays **0.1 ohms**.

If this is set to **Auto**, the amplifier adjusts the maximum voltage and current to maximise output power for the measured load impedance.

See also, [Load matching \(page 40\)](#).

To update the drive load

1. Press **OUTPUT** to select the channel. For details, see [Selecting the output channel \(page 23\)](#).
2. Press the down arrow button ▼ several times until **DRIV** appears top left (usually two presses).
3. Rotate **ADJUST** (the right-hand dial) to choose the load. The possible values are: 25V Line, 70V Line, 100V Line, 2 ohm, 3 ohm, 4 ohm, 6 ohm, 8 ohm or Auto (see above).
4. Press **UTILITY** to exit the menu or press **OUTPUT** several times to step through the channels.

Output routing

Outputs can be driven from any DSP input. This routing is the fundamental means by which Drive Modules are created. By default, routing always uses consecutive channels. However, you can create non-consecutive Drive Modules. For further details, see [Drive modules \(page 6\)](#).

To update routing

1. Press **OUTPUT** to select the channel. For details, see [Selecting the output channel \(page 23\)](#).
2. Press the down arrow button ▼ several times until **ROUT** appears top left (usually three presses).
3. Rotate **ADJUST** (the right-hand dial) to choose None, DSP A, DSP B, DSP C or DSP D.
4. Press **UTILITY** to exit the menu or press **OUTPUT** several times to step through the channels.

Limiters

The iKON amplifiers include three limiters in the output signal path:

- [VX limiter \(page 24\)](#)
- [Thermal limiter \(page 25\)](#)
- [Excursion limiter \(page 25\)](#)



Although these limiters offer protection for amplifiers and drivers, they can never protect from all possible scenarios. Martin Audio is not responsible for any damage that might occur.

Output VX limiter

Use the **LIM** menu item to configure the VX limiter. This is one of [three output limiters \(page 24\)](#) in the amplifier.

The VX limiter is a peak-detecting signal limiter. The VX mode parameter determines the style of limiter. When Virtual Crossover (VX) mode is off, the limiter is controlled in a conventional manner; the only controls being Threshold and Overshoot.

The Overshoot limiter prevents the signal from exceeding the threshold during the attack phase of the main limiter by more than a predetermined amount. The optimal Overshoot setting is usually about 8 dB. Overshoot settings lower than this will sound progressively 'harder'.

When VX mode is on, you can choose the crossover point of a 'virtual crossover', which incorporates two limiters per output so you can individually limit the drivers in a passive two-way enclosure using individual thresholds and optimised attack and release characteristics for each. The Threshold of the second 'Hi' limiter is set relative to the threshold of the first 'Lo' limiter.

This Limiter introduces some delay. With VX mode off, this delay will depend on the lowest high pass frequency used in the crossover filters in a given [Drive Module \(page 6\)](#). With VX mode on, the delay is related to the Split frequency. This delay will be applied to all of the outputs in a given Drive Module to keep them in phase. For further details, see [Latency delay \(page 52\)](#).

To update limiter settings

1. Press **OUTPUT** to select the channel. For details, see [Selecting the output channel \(page 23\)](#).
2. Press the down arrow button ▼ several times until **LIM** appears top left (usually three presses).
3. Rotate **ADJUST** (the right-hand dial) to change **Thresh** the threshold value.
4. Rotate **SELECT** (the left-hand dial) to choose **Over** and rotate **ADJUST** (the right-hand dial) to change the overshoot value (see above).
5. Rotate **SELECT** (the left-hand dial) to choose **VxMde** and rotate **ADJUST** (the right-hand dial) to switch VX mode on or off (see above).
6. Press **UTILITY** to exit the menu or press **OUTPUT** several times to step through the channels.

Output thermal limiter

The thermal limiter is designed to protect the driver against damage due to over-heating. This is one of [three output limiters \(page 24\)](#) in the amplifier. You configure this using the **Tmax** menu item.

The thermal limiter models the temperature of the driver and constrains the output signal level in order to keep the average output power below a predetermined limit. It applies attack and release characteristics to go some way towards modelling the complex thermal circuit of a driver's voice coil and magnet assembly.

There are three parameters:

- **Threshold** – The continuous RMS voltage which the driver should be able to withstand. This is calibrated at the output of the amplifier. You can switch off the thermal limiter by setting the threshold to off.
- **Attack** – The time-constant of the speed at which the driver heats up (in seconds).
- **Release** – The time-constant of the speed at which the driver cools down (expressed as a multiple of the attack time).

To update thermal limiter settings

1. Press **OUTPUT** to select the channel. For details, see [Selecting the output channel \(page 23\)](#).
2. Press the down arrow button ▼ several times until **Tmax** appears top left (usually five presses).
3. Rotate **ADJUST** (the right-hand dial) to change **Thresh** the threshold value. To switch off the thermal limiter, rotate the dial to the right until **Off** appears.
4. Rotate **SELECT** (the left-hand dial) to choose **Attack** and rotate **ADJUST** (the right-hand dial) to change the attack value (0.01 to 34.4 s).
5. Rotate **SELECT** (the left-hand dial) to choose **Rel** and rotate **ADJUST** (the right-hand dial) to change the release value (1.0X to 16.4X).
6. Press **UTILITY** to exit the menu or press **OUTPUT** several times to step through the channels.

Output excursion limiter

Use the **Xmax** menu item to update the excursion limiter settings. This is one of [three output limiters \(page 24\)](#) in the amplifier.

The excursion limiter protects the driver against excessive linear movement of the cone and voice-coil which

could otherwise cause mechanical damage. Since this movement (excursion) is largely related to the inverse of the signal frequency, drivers are prone to being damaged by very low frequencies. This limiter is progressively more sensitive at lower frequencies and, rather than varying the gain to provide the limiting action, it uses a sliding high pass filter to progressively curtail the low-frequency response, effectively limiting the linear excursion to below the Xmax specification of the driver.

To set the limiter up, it is necessary to know the shape of the family of Excursion versus Frequency curves of the driver for various drive voltage levels. A curve should then be chosen where the slope is high, where it passes through the specified Xmax value for the driver. The peak voltage and frequency of this point should then be noted.

The Xmax limiter is usually then set up using just two parameters:

- **Threshold** – the peak voltage of the point arrived at above. This is calibrated at the output of the amplifier. The Excursion Limiter can be defeated by setting Threshold to Off.
- **Frequency** – The frequency at which the above threshold voltage is appropriate.

A further parameter **Min** may also be available for more advanced applications. This allows the increasing limiting action at lower frequencies to level-off below a certain frequency. In most application, this would be left set to its default value of 5Hz.

To update excursion limiter settings

1. Press **OUTPUT** to select the channel. For details, see [Selecting the output channel \(page 23\)](#).
2. Press the down arrow button ▼ several times until **Xmax** appears top left (usually six presses).
3. Rotate **ADJUST** (the right-hand dial) to change **Thresh** the threshold value (1 to 201V or **Off**).
4. Rotate **SELECT** (the left-hand dial) to choose **Freq** and rotate **ADJUST** (the right-hand dial) to change the frequency (10 to 1,000 Hz).
5. Press **UTILITY** to exit the menu or press **OUTPUT** several times to step through the channels.

Bridge mode

If you select bridge mode, two amplifier channels drive one loudspeaker with greater power. In this mode, only one set of output controls is active per pair of amplifier

channels since both of the amplifiers in the pair are driven with the same signals, as determined by the left-hand (lower numbered) channel of the pair. Bridge settings should be set up before recalling Drive Module presets. Module Preset Recall will see a bridged pair of outputs as a single channel. When Bridged, the partner (even numbered) channel doesn't show any signal on the limiter meter, though the amplifier protection indicator does still operate. For this channel, the mute button doesn't operate and you can't update any of the output channel parameters.

Note that the gain of a bridged pair of channels is 6 dB higher than a single channel. As the gain for a single channel (with all DSP level controls set to 0 dB) is 32 dB, the gain for a pair of bridged channels is 38 dB. This may impact limiter settings and the balance of levels in a system where some amplifier channels are bridged and others are in standard mode.

To bridge or unbridge two channels

1. Press **OUTPUT** to select the channel. For details, see [Selecting the output channel \(page 23\)](#).

To bridge channels, you must select an odd-numbered channel. For example, to bridge channels 3 and 4, select channel 3.

2. Press the down arrow button ▼ several times so that **AMP** appears top left (usually seven presses).



This menu item doesn't exist for even-numbered channels.

3. Rotate **ADJUST** (the right-hand dial) to set **Bridge** to **On** or **Off**.

If you bridge channels, an orange bridge indicator lights up between the two channels on the right-hand side of the [front panel \(page 9\)](#).

4. Press **UTILITY** to exit the menu or press **OUTPUT** several times to step through the channels.

Output FIR

For output FIR, there are ten stages of equalisation available for each channel:

- Two shelving filters: the [high shelf filter \(page 26\)](#) and the [low shelf filter \(page 27\)](#).
- [Eight parametric filters \(page 26\)](#).

You can also apply a [high pass filter \(page 27\)](#) and a [low pass filter \(page 27\)](#).

Note that the amplifier also has 1,000 FIR filter taps at 48 kHz on each output channel. This is reserved for optimised systems and Martin Audio's **Display** software. You can't upload your own file.

Output high shelf filter

Use the **EQ<** menu item to edit the high shelf filter for the output channel. You can update the frequency, slope and gain. For details of FIR, see [output FIR \(page 26\)](#). The high shelf filter is shown as **HS** in [Vu-Net \(page 36\)](#).

To edit the high shelf filter

1. Press **OUTPUT** to select the channel. For details, see [Selecting the output channel \(page 23\)](#).
2. Press the up arrow button ▲ several times until **EQ<** appears top left (usually thirteen presses).
3. Rotate **ADJUST** (the right-hand dial) to change the frequency.
4. Rotate **SELECT** (the left-hand dial) to choose **Slope** and rotate **ADJUST** (the right-hand dial) to update the slope.
5. Rotate **SELECT** (the left-hand dial) to choose **Gain** and rotate **ADJUST** (the right-hand dial) to update the gain.
6. Press **UTILITY** to exit the menu or press **OUTPUT** several times to step through the channels.

Output parametric EQ filters

For each of the eight output parametric filters you can specify the frequency, bandwidth and gain. For details of FIR, see [output FIR \(page 26\)](#).

Note that the amplifier also has [input parametric EQ filters. \(page 21\)](#)

To update the eight parametric filters

1. Press **OUTPUT** to select the channel. For details, see [Selecting the output channel \(page 23\)](#).
2. Press the up arrow button ▲ several times until **EQ1** appears top left (usually five presses).
3. Rotate **ADJUST** (the right-hand dial) to choose the frequency.

4. Rotate **SELECT** (the left-hand dial) to choose **Width** and rotate **ADJUST** (the right-hand dial) to update the bandwidth in **Q** or **octaves** (page 32).
5. Rotate **SELECT** (the left-hand dial) to choose **Gain** and rotate **ADJUST** (the right-hand dial) to update the gain (0.2 dB increments).
6. Press the up arrow button ▲ again so that **EQ2** appears top left. Update the second parametric filter and repeat for all eight parametric filters.
7. Press **UTILITY** to exit the menu or press **OUTPUT** several times to step through the channels.

Output low shelf filter

Use the **EQ>** menu item to edit the low shelf filter for the output channel. You can update the frequency, slope and gain. For details of FIR, see [output FIR \(page 26\)](#). The low shelf filter is shown as **LS** in [Vu-Net \(page 36\)](#).

To edit the low shelf filter

1. Press **OUTPUT** to select the channel. For details, see [Selecting the output channel \(page 23\)](#).
2. Press the up arrow button ▲ several times until **EQ>** appears top left (usually four presses).
3. Rotate **ADJUST** (the right-hand dial) to change the frequency.
4. Rotate **SELECT** (the left-hand dial) to choose **Slope** and rotate **ADJUST** (the right-hand dial) to update the slope.
5. Rotate **SELECT** (the left-hand dial) to choose **Gain** and rotate **ADJUST** (the right-hand dial) to update the gain.
6. Press **UTILITY** to exit the menu or press **OUTPUT** several times to step through the channels.

Output low pass filter

Use the **LPF** menu item to edit the low pass filter for the output channel. You can update the frequency and the filter type. The filter types available are the same as for the [high pass filter \(page 27\)](#).

To edit the low pass filter

1. Press **OUTPUT** to select the channel. For details, see [Selecting the output channel \(page 23\)](#).

2. Press the up arrow button ▲ several times until **LPF** appears top left (usually three presses).
3. Rotate **ADJUST** (the right-hand dial) to change the frequency. To remove the low pass filter, turn the dial to the right until **Out>>** appears.
4. Rotate **SELECT** (the left-hand dial) to choose **Shape** and rotate **ADJUST** (the right-hand dial) to select the low pass filter type (see above).
5. Press **UTILITY** to exit the menu or press **OUTPUT** several times to step through the channels.

Output high pass filter

Use the **HPF** menu item to edit the high pass filter for the output channel. You can update the frequency and the filter type:

1st	Not supported in Vu-Net (page 36)
Bes12	Bessel 12 dB
But12	Butterworth 12 dB
LR12	Linkwitz-Riley 12 dB
Bes18	Bessel 18 dB
But18	Butterworth 18 dB
Bes24	Bessel 18 dB
But24	Butterworth 24 dB
LR24	Linkwitz-Riley 24 dB
Har4th	Hardman 4th order – Not supported in Vu-Net (page 36)
But48	Butterworth 48 dB
LR48	Linkwitz-Riley 48 dB
Har8th	Hardman 8th order – Not supported in Vu-Net (page 36)
LIR	Linear impulse response – Not supported in Vu-Net (page 36)

Hardman filter

The Hardman type filter is always described by its order. This is because the filter becomes progressively steeper rather than following a linear slope and so a dB/octave description is not accurate.

Linear impulse response filter

Unique to Martin Audio, linear impulse response (LIR) crossover filtering gives a linear phase crossover that has a constant delay regardless of frequency. This is unlike other types of crossover that delay different frequencies to a different extent, thus smearing the arrival time. The LIR crossover can therefore be described as having a flat group delay response and is thus entirely free of group delay distortion. Common FIR filtering can provide this too, but FIR filtering does have complications and disadvantages when compared with LIR filtering.

The shape of the LIR crossover filter is similar to a 4th order Linkwitz-Riley filter and maintains zero phase difference between the adjacent bands across the crossover region to keep the polar response rock steady.

Note that very narrow bandwidths are not possible with this crossover type. If the low pass frequency is too close to the high pass frequency, then the filter will 'mute'.

Linear phase filtering necessarily introduces delay; the laws of physics demand it. To keep this delay to a minimum, we recommend that more conventional crossover shapes (such as Linkwitz-Riley) are used for the very lowest frequency high pass edge, particularly if this is less than about 100 Hz, which is well below the frequency thought to cause audible 'Group Delay Distortion'.

This constant delay will depend on the lowest high pass frequency used in the crossover filters in a given [Drive Module \(page 6\)](#). For further details, see [Latency delay \(page 52\)](#).

To edit the high pass filter

1. Press **OUTPUT** to select the channel. For details, see [Selecting the output channel \(page 23\)](#).
2. Press the up arrow button ▲ several times until **HPF** appears top left (usually two presses).
3. Rotate **ADJUST** (the right-hand dial) to change the frequency. To remove the high pass filter, turn the dial to the left until <<**Out** appears.
4. Rotate **SELECT** (the left-hand dial) to choose **Shape** and rotate **ADJUST** (the right-hand dial) to select the high pass filter type (see above).
5. Press **UTILITY** to exit the menu or press **OUTPUT** several times to step through the channels.

Output delay

Use the **DEL** menu item to add a delay to an output channel. See also [Latency delay \(page 52\)](#).

To update output delay

1. Press **OUTPUT** to select the channel. For details, see [Selecting the output channel \(page 23\)](#).
2. Press the up arrow button ▲ several times until **DEL** appears top left (usually one press).
3. Rotate **ADJUST** (the right-hand dial) to change the delay in ms. To remove the delay, set the delay to 0 ms.

4. Press **UTILITY** to exit the menu or press **OUTPUT** several times to step through the channels.

Updating utilities

From the utility menu you can choose:

- **DevID** – see [DevID \(page 29\)](#)
- **STER** – see [Stereo linking \(page 29\)](#)
- **DANT** – see [Dante name \(page 29\)](#)
- **VER** – see [Firmware version \(page 29\)](#)
- **ECO** – see [Power saving \(page 30\)](#)
- **PWR** – see [External breaker protection \(page 31\)](#)
- **ALM** – see [Alarm \(page 31\)](#)
- **Aux** – see [AUX style \(page 32\)](#)
- **ParaEQ** – see [Parametric EQ bandwidth \(page 32\)](#)
- **Screen** – see [Screen contrast \(page 32\)](#)
- **RECL** – see [Recall snapshot \(page 32\)](#)
- **STOR** – see [Store snapshot \(page 32\)](#)
- **IP Static** – see [Static IP address \(page 33\)](#)
- **IP Mode** – see [IP mode \(page 33\)](#)
- **IP Curr** – see [Current IP address \(page 33\)](#)

DevID

We added **DevID** (Device ID) in firmware 1.700. **DevID** is for future use.

Stereo linking

You can stereo link inputs A and B and/or inputs C and D. If you link two inputs and then edit one of them, the amplifier automatically updates both.



You can only link inputs that are of equal size.

The amplifier stores the stereo linking state in [snapshots \(page 15\)](#) but not in [presets \(page 13\)](#).

To stereo link channels

1. Press **UTILITY**.
2. Press the down arrow button ▼ once so that **STER** appears top left. If you have firmware 1.680 or earlier, you don't need to do this as **STER** is the first item in the menu.

3. Rotate **SELECT** (the left-hand dial) to highlight the text below **Link A** or **Link C**.
4. Rotate **ADJUST** (the right-hand dial) .
 - To link inputs A and B, select **Link A** on the top line and **To B** below.
 - To link inputs C and D, select **Link C** on the top line and **To D** below.
 - To unlink inputs, select **None**.
5. Press **UTILITY** to exit the menu.

Dante name

The **DANT** menu item displays the unique amplifier name used with [Dante \(page 16\)](#). You can only change the Dante name using the **Dante Controller** software. You can't change the Dante name at the front panel or in [Vu-Net \(page 36\)](#).

To view the Dante name

1. Press **UTILITY**.
2. Press the down arrow button ▼ twice (once with firmware 1.680 and earlier) so that **DANT** appears top left. The Dante name for this amplifier is bottom right.
3. Press **UTILITY** to exit the menu.

Firmware version

The **VER** menu item displays the firmware and [Dante \(page 16\)](#) version numbers.

- To update the firmware, use [Vu-Net \(page 36\)](#).
- To update Dante, use the **Dante Controller** software.

To view the firmware version

1. Press **UTILITY**.
2. Press the down arrow button ▼ three times (two times with firmware 1.680 and earlier) so that **VER** appears top left. The screen shows the amplifier model, the firmware version (under the heading **Ver**) and the Dante version.
3. Press **UTILITY** to exit the menu.

Power saving

Use the **ECO** menu item to specify **standby** or **sleep** timeout settings in minutes. For example:

- With **standby** set to 10, the amplifier automatically goes into standby after 10 minutes without an audio signal.
- With **sleep** set to 30, the amplifier automatically goes to sleep after 30 minutes without an audio signal.

Note that you can also use the **ECO** menu to put the amplifier straight into **standby** manually.

Standby

- In **standby**, the amplifier uses less power than normal and can wake up instantly.
- If there is a **standby** timeout setting and the unit detects an audio signal, it will come out of standby instantly and automatically.
- If **standby** is set to manual, the amplifier will only come out of standby manually; it won't come out of standby when audio signal restarts.
- In **standby** the front screen remains lit and the up-arrow button ▲ flashes every five or six seconds to show you that you can press this button to come out of standby.



When the amplifier goes into standby, it checks for high residual voltage in the main PSU. If it detects this, it switches on the fast fan to discharge this power and protect the amplifier. Discharging the power can take a few minutes or sometimes longer depending on the amount of power that needs to be discharged.

Sleep

- In **sleep**, the amplifier uses minimal power (significantly less than in standby) and takes about a minute to wake up, as it goes through the normal startup checks.
- In **sleep** the front panel is off and the amplifier can't wake up automatically. It only comes out of sleep when you wake it up.
- In **sleep**, the amplifier appears to be switched off, but the front panel power switch is set to on and

[Vu-Net \(page 36\)](#) can still communicate with the amplifier.

Choosing standby or sleep

To save energy overnight with amplifiers kept indoors, use **sleep** rather than **standby**. Note that to put the amplifier straight into sleep mode rather than waiting for the timeout, you need to use [Vu-Net \(page 36\)](#) or an [external controller \(page 46\)](#), as you can't do this at the front panel.

To save energy overnight with touring amplifiers, **standby** is often the better choice. Touring amplifiers are frequently exposed to fluctuating temperatures, and in **standby** mode, the amplifier fans can help prevent condensation. In contrast, the fans are turned off in **sleep** mode.



Standby and sleep can be confusing as:

- **Standby** is similar to **sleep** in Windows and macOS.
- **Sleep** is similar **standby** or **hibernate** in macOS or **hibernate** in Windows.

Also, the parameter names on the **ECO** menu are confusing as you set the standby timeout under the parameter name **Save**.

The default settings for **standby** and **sleep** are **manual**, which means that:

- The amplifier only goes into standby or sleep if you select them manually.
- The amplifier will only come out of standby or sleep if you bring them out manually.

To bring the amplifier out of standby

Do one of the following:

- At the **front panel**, press the (flashing) up arrow ▲ button.
- Use [Vu-Net \(page 36\)](#).
- Use an [external controller \(page 46\)](#).

To bring the amplifier out of sleep

Do one of the following:

- At bottom left of the **front panel**, switch the power off, wait for a couple of seconds and then switch it on again.
- Use [Vu-Net \(page 36\)](#).
- Use an [external controller \(page 46\)](#).

To change standby or sleep settings

1. Press **UTILITY**.
2. Press the down arrow button ▼ four times (three times with firmware 1.680 and earlier) so that **ECO** appears top left.
3. **To choose a standby timeout** rotate **SELECT** (the left-hand dial) to highlight the text below **Save** and rotate **ADJUST** (the right-hand dial) to select a number of minutes (3 to 89). For example, if this is 30, the amplifier will go into standby after 30 minutes without an audio signal. In this case, as soon as the amplifier detects audio, it will come out of standby instantly and automatically.
4. **To switch off automatic standby** rotate **SELECT** (the left-hand dial) to highlight the text below **Save** and rotate **ADJUST** (the right-hand dial) to the right until **Man** appears. This selects manual standby mode (the default setting). Note that if you now put the amplifier into standby, it won't come out of standby automatically when there is audio signal. It will only come out of standby if you bring it out of standby manually (see above).
5. **To select a sleep timeout** rotate **SELECT** (the left-hand dial) to highlight the text below **Sleep** and rotate **ADJUST** (the right-hand dial) to select a number of minutes (3 to 89). For example, if this is 60, the amplifier will go to sleep after 60 minutes without an audio signal. Note that the amplifier won't come out of sleep automatically. It will only come out of sleep if you bring it out of sleep manually (see above).
6. **To switch off automatic sleep** rotate **SELECT** (the left-hand dial) to highlight the text below **Sleep** and rotate **ADJUST** (the right-hand dial) to the right until **Man** appears. This selects manual sleep mode (the default setting).
7. **To put the amplifier straight into standby** rotate **SELECT** (the left-hand dial) to highlight the text below **S'dby** and rotate **ADJUST** (the right-hand dial) to the left. The text changes from **Now<<** to **Bye** and the amplifier goes straight into standby.



The two left arrows (<<) after the word **Now** are to remind you that to select standby you rotate **ADJUST** (the right-hand dial) to the left.

Note that If standby is automatic (if **Save** is set to a timeout between 3 and 89), the amplifier will come out of standby automatically if it detects an audio signal.

If standby is manual (if **Save** is set to **Man**), the amplifier won't come out of standby automatically if it detects an audio signal. It will only come out of standby if you bring it out of standby manually (see above).

8. Press **UTILITY** to exit the menu.

External breaker protection

If you use the amplifier on a mains supply with a restricted capacity, use external breaker protection (EBP) to limit the output power. This will avoid the nuisance of tripping mains circuit breakers or fuses. Set the EBP value to be the same value as the circuit breaker or fuse.

To set External Breaker Protection

1. Press **UTILITY**.
2. Press the down arrow button ▼ five times (four times with firmware 1.680 and earlier) so that **PWR** appears top left.
3. Rotate **ADJUST** (the right-hand dial) to select the amp value (between 9 and 50 A). The screen displays the draw (which you can't edit).
4. Press **UTILITY** to exit the menu.

Alarm

The **ALM** screen allows you to choose whether the **Fault relay port (page 53)** triggers for faults only or faults and warnings. Note if you select faults and warnings, you can't tell the faults and warnings apart as they both trigger in the same way.

For further details, see [Fault relay port \(page 53\)](#).

To edit the relay action for alarms

1. Press **UTILITY**.

- Press the down arrow button ▼ six times (five times with firmware 1.680 and earlier) so that **ALM** appears top left.
- Rotate **SELECT** (the right-hand dial) to choose:
 - **Fault only** – The fault relay port only triggers when the amplifier has a fault where it has stopped working (or when the power is off).
 - **Fault or Check** – The fault relay port triggers for faults and warnings (and when the power is off). A warning means that the amplifier is still working, but we recommend that you **check** the amplifier. This is why the menu item has the word **check** in it.
- Press **UTILITY** to exit the menu.

AUX style

This allows you to view or update the way that the amplifier responds to signals sent to the **AUX port** (page 43).

To update the AUX style

- Press **UTILITY**.
- Press the down arrow button ▼ seven times (six times with firmware 1.680 and earlier) so that **Aux** appears top left.
- Rotate **ADJUST** (the right-hand dial) to select the AUX style. For details of the AUX styles, see **AUX port** (page 43).
- Press **UTILITY** to exit the menu.

Parametric EQ bandwidth

This allows you to choose whether to edit the bandwidth of the parametric equalisers in octaves or Q. This applies to the **Input parametric EQ filters** (page 21) and the **Output parametric EQ filters** (page 26).

To set the parameter EQ bandwidth

- Press **UTILITY**.
- Press the down arrow button ▼ eight times (seven times with firmware 1.680 and earlier) so that **ParaEQ** appears top left.
- For octaves, rotate **ADJUST** (the right-hand dial) to select **BW=oct**.
For Q, rotate **ADJUST** (the right-hand dial) to select **BW=Q**.

- Press **UTILITY** to exit the menu.

Screen contrast

This allows you to change the screen contrast.

To update the screen contrast

- Press **UTILITY**.
- Press the down arrow button ▼ nine times (eight times with firmware 1.680 and earlier) so that **Screen** appears top left.
- Rotate **ADJUST** (the right-hand dial) to select a screen contrast between 0 and 100%. You can't edit **Check1** and **Check2**.
- Press **UTILITY** to exit the menu.

Recall snapshot

This allows you to recall a **saved set of amplifier settings** (page 32). For further details, see **Snapshots** (page 15).

To recall a snapshot

- Press **UTILITY**.
- Press the down arrow button ▼ ten times (nine times with firmware 1.680 and earlier) so that **RECL** appears top left.
- Rotate **ADJUST** (the right-hand dial) to select the snapshot number (between 1 and 20).
- Press **ENTER**.
- Press **ENTER** again to confirm or press the down arrow button ▼ to cancel.
- Press **UTILITY** to exit the menu.

Store snapshot

This allows you to save a set of amplifier settings. To recall the settings, use **Recall snapshot** (page 32).



You need to store presets before you can store snapshots.

For further details, see **Snapshots** (page 15).

To store a snapshot

1. Press **UTILITY**.
2. Press the down arrow button **▼** eleven times (ten times with firmware 1.680 and earlier) so that **STOR** appears top left.
3. Rotate **ADJUST** (the right-hand dial) to select the snapshot number to use (between 1 and 20).
4. Press **ENTER**.
5. You can now enter a name for the snapshot (up to 12 characters).

Rotate **ADJUST** (the right-hand dial) to select each character. Scrolling right gives A to Z followed by six symbols followed by a to z in lower case. Scrolling left gives the numbers 0 to 9 and some symbols.

Rotate **SELECT** (the left-hand dial) to move forward or backward in the name.

6. Press **ENTER**.
7. Press **ENTER** again to confirm or press the down arrow button **▼** to cancel.
8. Press **UTILITY** to exit the menu.

Static IP address

The **IP Static** screen allows you to specify the IP address of the amplifier.



The **IP Static** screen only appears in the utility menu if you've selected static IP using **IP mode** (page 33). If you're using automatic IP, this menu item won't appear in the utility menu.

To edit the IP address

1. Press **UTILITY**.
2. Press the up arrow button **▲** twice and check the **IP mode** (page 33). If it's auto, change it to static.
3. Press the up arrow button **▲** once so that **IP Static** appears top left.
4. Rotate **ADJUST** (the left-hand dial) to select the part of the address to edit.
5. Rotate **SELECT** (the right-hand dial) to update the address.

6. Press **UTILITY** to exit the menu.

IP mode

The **IP Mode** screen allows you to choose static or automatic IP addressing.

If you're using static IP, the home screen shows the IP address on the top line as flashing text.



If you change IP mode from static to automatic, you will need to wait for the amplifier to pick up an address. This could take a few minutes.

To edit the IP mode

1. Press **UTILITY**.
2. Press the up arrow button **▲** twice so that **IP Mode** appears top left.
3. Rotate **SELECT** (the right-hand dial) to choose **Static** or **Auto**.
4. To adjust the subnet mask, rotate **ADJUST** (the left-hand dial) to the right to highlight the subnet mask. Then rotate **SELECT** (the right-hand dial) to choose a mask value between 1 and 29.
5. If you've chosen static IP, press the up arrow **▲** once so that **IP Static** appears top left. Use that screen to specify the **Static IP address** (page 33).
6. Press **UTILITY** to exit the menu.

Current IP address

If you are using **auto IP** (page 33), the **IP Curr** screen displays the current Ethernet IP address. You can't edit this automatically assigned IP address.

If you're using **static IP** (page 33), press up arrow **▲** twice from the **IP Curr** screen to go to the **Static IP address screen** (page 33).

To view the IP address

1. Press **UTILITY**.
2. Press the up arrow button **▲** once so that **IP Curr** appears top left. The IP address is divided into three

sections. For example, IP address 169.254.241.120 appears like this:

Curr		
169.254	241	120

3. Press **UTILITY** to exit the menu.

Ethernet

Ethernet configurations

IP addressing by the iK81 can be completely automatic, with no setup required. To select auto IP, see [IP mode \(page 33\)](#).

When first installing and launching [Vu-Net \(page 36\)](#), the computer Firewall may ask you to allow Vu-Net to access the network.



Allow Vu-Net to have access to both private and public networks.

DHCP

There are two primary IP address ranges:

- One used when there is a DHCP server.
- Another ('Link Local') used when there is no DHCP server. In this case the device and computer will use 'Auto IP' to allocate themselves an IP address.

Both the device and the computer must be in the same IP address range. In a local network environment such as an office where there is a DHCP server, both the computer and the device will be in the DHCP IP address range and will connect immediately.

Auto IP

When you turn on the amplifier, the **ONLINE** Indicator flashes on the [front panel \(page 9\)](#) to show that the amplifier is searching for a DHCP server. If this fails, the amplifier uses Auto IP to allocate an IP address. This means that if you aren't using a DHCP server, it can take several minutes for your computer to connect to your amplifier.

Static IP

To select static IP, see [IP mode \(page 33\)](#).

To select the IP address, see [Static IP address \(page 33\)](#).

If the amplifier or computer has a static IP address and a different IP address range (i.e. a different subnet), [Vu-Net \(page 36\)](#) may not be able to 'see' the device.

IP Troubleshooting

If [Vu-Net \(page 36\)](#) can't connect to the amplifier:

- A router acting as a DHCP server provides a trouble-free way of administering IP addresses. Always switch on any DHCP server before you connect the computer or amplifier to the network.
- If you're not using a DHCP server, check that the [current IP address \(page 33\)](#) of the device is compatible with the IP address of the computer. Generally, the leftmost six digits (two sets of three) should be the same for the amplifier and computer.
- If there is no router in the system acting as a DHCP server, wait 10 minutes (for the computer to acquire the correct IP address) and try again.
- Check that your computer firewall is allowing Vu-Net to access both private and public networks.

Vu-Net software

Martin Audio's Vu-Net software allows you to control and monitor iKON amplifiers from a PC. To do this, connect the amplifiers and PC using an Ethernet network and run Vu-Net on the PC. Vu-Net also allows you to control and monitor many Martin Audio loudspeaker systems.

Vu-Net is a Windows app available as a free download from our website martin-audio.com.



We don't support macOS, but we know that some users run this app successfully on virtual platforms such as Parallels Desktop, VMware Fusion and Apple Boot Camp Assistant.

- Output current: Driver current (A) – For each output, the average current being delivered to the driver.
- Load impedance: Driver impedance (ohm) – For each output, the average impedance of the driver.
- Global protection systems: Protection limiting (dB) – For each output, the amount that the amplifier is 'dimming' itself in order to protect itself from potential damage.

To download Vu-Net

1. Visit our website martin-audio.com and select **Support > Software**.
2. Scroll to the **Vu-Net** section and click **DOWNLOAD VU-NET**.

Using Vu-Net

For full details, see the **Vu-Net User Guide**.

To download the Vu-Net User Guide

1. Visit our website martin-audio.com and select **Support > Software**.
2. Scroll to the **Vu-Net** section and click **USER GUIDE**.

Performance logging

[Vu-Net \(page 36\)](#) allows you to see graphs of performance against time, recording events over a period of up to three days. Breaks in the log due to power-downs are shown in blue. The graphs show:

- Supply current (A) – How much current is being supplied to the device via the mains inlet.
- Power systems: DC link voltage (V) – The voltage which is derived from the mains supply voltage.
- Thermal management: Thermal capacity (%) – The percentage of the available thermal capacity that has been used.

Installation

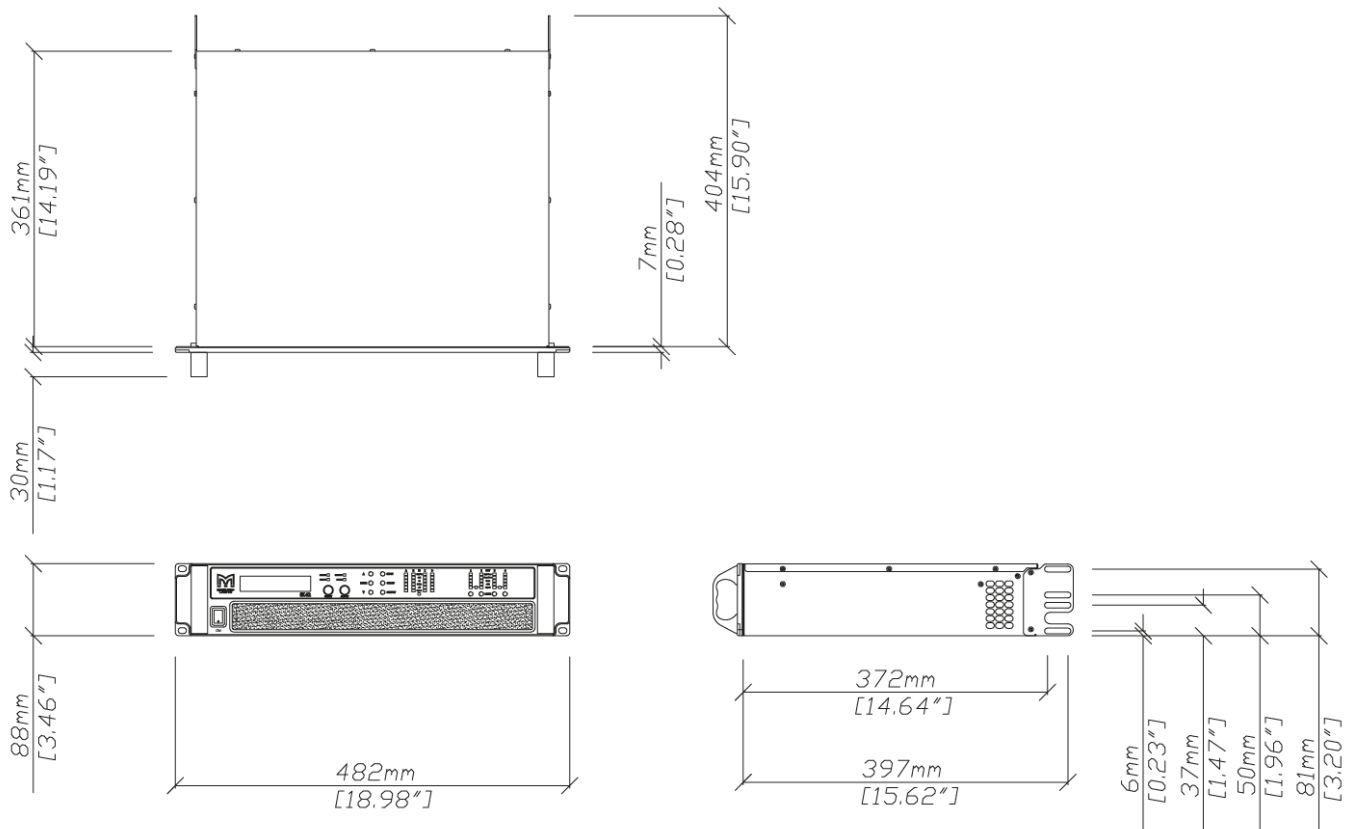

iKON amplifiers are designed to be mounted in standard 19-inch rack enclosures.

If you have a fixed installation, with the bottom unit supported and no gaps between units, you can just use the front panel 19-inch rack holes.

If you have a mobile rack, you must support the rear of the units with [rack ears](#) (page 41). Any damage caused by insufficient rack support is not covered by the warranty.

To prevent damage to the front panel, we recommend that you fit plastic cups or washers underneath the rack-mounting bolt heads.

You can mount multiple iKON amplifiers without any ventilation gaps between them. However, you must make sure that there is an unobstructed flow of clean air from the front to the rear of the units. You must not cover the air intakes on the front of the units or the exhaust vents on the rear of the units. You must make sure that you aren't

just continually circulating hot air through the amplifiers from the back of the rack to the front.

The amplifier should never be exposed to rain or moisture during operation or storage. If the unit does come into contact with moisture, remove the AC power cable immediately and leave the unit in a warm location to dry out.

Note that when equipment is taken from a cold location to a hot humid one, condensation can form inside the device. Before you connect the AC power cable, always allow time for equipment to reach the same temperature as the surrounding environment.



Keep your amplifier away from dirt, liquids and vapour from theatrical smoke and fog machines.

Damage from these sources isn't covered by the warranty.

initially selected range. If the mains voltage is outside that range the amplifier will enter protection mode and briefly display the message **Mains out of range** followed by one of the messages above. In protection mode, audio will be muted but communication with the amplifier will still be possible. The amplifier will continue to monitor the mains and will automatically resume normal operation if the mains is stable and has returned to the initial range selected when the unit was first powered up.

AC power connection

The amplifier uses a 32A Neutrik powerCON chassis connector, which is a locking AC power connector. To allow you to choose the appropriate cable length, cable type and plug type, we supply the powerCON cable connector but not the mains cable. If you use an AC power cable with its own powerCON connector, make sure that this connector is the correct type.

The amplifiers are designed to operate on 50 to 60 Hz AC power (threshold 47 to 63 Hz). The power supply sections automatically configure themselves for either 100-120 V or 220-240 V nominal voltage at start-up. The amplifiers will operate over an extended range of supply voltage with thresholds as follows:

- 100-120 V range thresholds 75-138 V
- 220-240 V range thresholds 138-275 V

Note that whilst the amplifier will operate correctly at the voltages indicated, the specified output power will only be achieved when operating with the stated nominal voltages.

Once an amplifier has configured itself for a particular range it will not change range, even if the mains voltage varies wildly, unless the power is completely interrupted for several seconds or you switch the amplifier off and on again.

During start-up the amplifier checks the mains environment and waits for the mains to settle within either the 100-120 V or 220-240 V ranges and the thresholds shown above. If the mains takes a long time to settle, the amplifier will display one of the following messages on the front panel:

Message	Problem
Mains too low	Voltage below the 100-120 V range threshold of 75 V
Mains too high	Voltage above the 220-240 V range threshold of 275 V
Mains unstable	Voltage within the 100-120 V or 220-240 V range but is unstable

When an amplifier is running normally, it continuously monitors the mains to ensure that it remains within the

Audio connections

Input connections

The audio input can be analogue, AES or Dante.

- For analogue, there are four female XLR connectors, one for each input channel.
- For AES, there is one female XLR for a single stream of two-channel AES3 digital audio. You can [route the two AES channels to input channels A and B \(page 19\)](#).
- For Dante, there are two RJ45 connectors, one primary and one secondary. You can [route four Dante channels to input channels A, B, C and D \(page 19\)](#). Note that for the iK81, you can route another four channels direct to output DSP using [Vu-Net \(page 36\)](#). This means that for the iK81, you can use eight channels of Dante.

Analogue audio connection

For analogue audio, we recommend that you use a balanced connection:

- HOT, + or 'in phase' connected to pin 2 of the XLR connector.
- COLD, – or 'out of phase' connected to pin 3 of the XLR connector.
- The chassis and cable shield connected to pin 1 of the XLR connector. This connection is required for EMC performance and regulations.

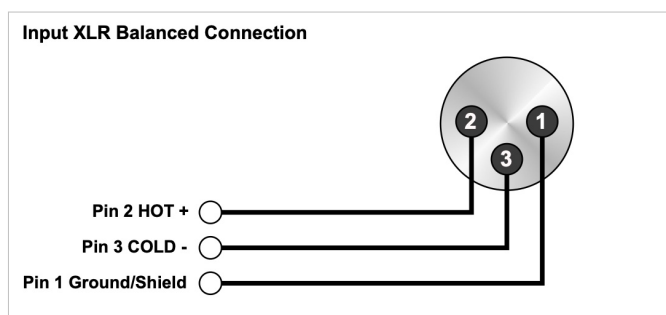

We don't recommend an unbalanced connection, but if you do need to do this, connect as follows:

- Signal conductor connected to pin 2 of the XLR connector.
- COLD or cable screen connected to pin 1 of the XLR connector with a short connection between pin 1 and pin 3.

Input XLR Unbalanced Connection

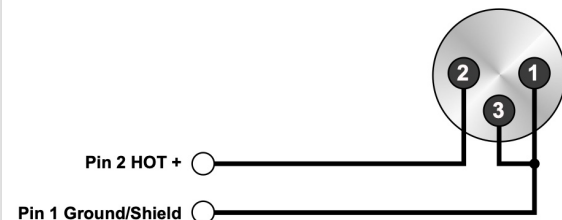

Output connections,

The iK41, iK42 and iK81 amplifiers have four speakON connectors for audio output.

- For the iK41 and iK42, there is one connector for each channel. The connectors are labelled 1, 2, 3 and 4 on the [back panel \(page 11\)](#).
- For the iK81, there is one connector for each pair of channels. The connectors are labelled 1&2, 3&4, 5&6 and 7&8 on the [back panel \(page 11\)](#). Connection 1&2 is for channels 1 and 2, connection 3&4 is for channels 3 and 4 and so on.

Note that you can connect more than one speaker to each channel, provided the total impedance per channel is 2 ohms or more. In [bridged mode \(page 25\)](#), the minimum total impedance is 4 ohms.

The iK41 and iK42 have one connector for each amplifier channel. You connect the loudspeaker to terminals 1+ and 1– as shown below:

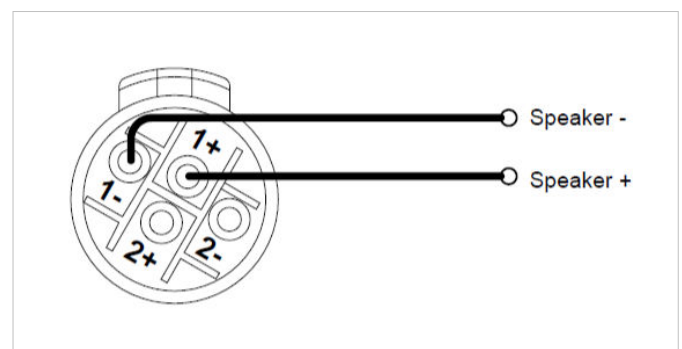

Alternatively, for the iK41 and iK42, you can use bi-amp wiring with connectors 1 and 3. This is because:

- Channel 2 output is duplicated on terminals 2+ and 2– of connection 1.

- Channel 4 output is duplicated on terminals 2+ and 2– of connection 3.

With iK41, iK42 and iK81 bi-amp wiring you connect two loudspeakers using one 4-core cable as follows:

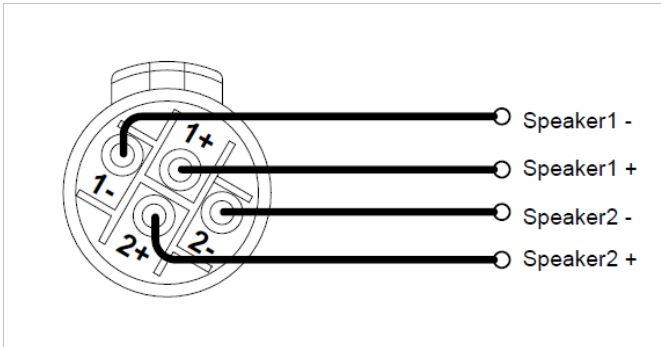

The iK81 has four bi-amp outputs with each speakON connector carrying two amplifier outputs. This means that for the iK81, you always use bi-amp wiring.

Bridge mode

If you [bridge \(page 25\)](#) a pair of amplifier channels, you connect to terminals 1+ and 2+ as follows:

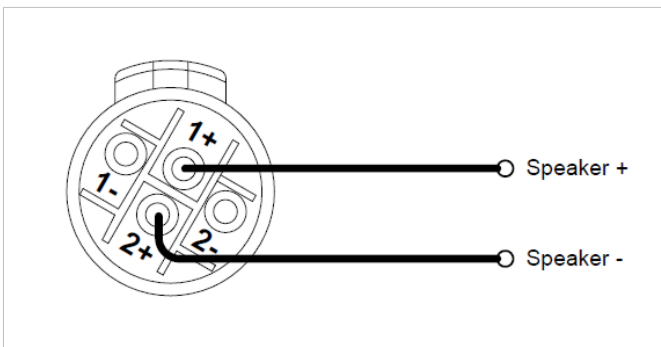

For the iK41 and iK42, this applies to connectors 1 and 3.

For the iK81, this applies to all four connectors.

Bridge mode example

In this example, an iK42 is powering two SXH218 subs in bridge mode, with one breakout cable to the first sub and a second cable between the subs:

- The breakout cable has two speakON connectors at one end for the iK42 and one speakON connector at the other end for the first SXH218.
- The speakON connectors for the iK42 plug into connectors 1 and 3.
- The cable between the subs runs from the link connector of the first SXH218 to the input connector of the second SXH218.

- The first SXH218 is powered by iK42 channels 1 and 2. The second SXH218 is powered by iK42 channels 3 and 4.

The connections for the breakout cable are as follows:

- iK42 connector 1 terminal 1+ to SXH218 input terminal 1+.
- iK42 connector 1 terminal 2+ to SXH218 input terminal 1–.
- iK42 connector 3 terminal 1+ to SXH218 input terminal 2+.
- iK42 connector 3 terminal 2+ to SXH218 input terminal 2–.

The SXH218 has cross-links between input and link, so the cable between the subs connects as follows:

- SXH218 link terminal 1+ to input terminal 1+ of the other SXH218.
- SXH218 link terminal 1– to input terminal 1– of the other SXH218.

This example also applies to SX218+ and SXHF218 because these subs also have cross-linking between input and link.

Load matching

Each output of the amplifier can be optimised to drive either a low impedance load (2, 3, 4, 6 or 8 ohm for iK41 and iK81; 2 or 3 ohm for iK42) or a constant voltage (25 V, 70 V or 100 V line).

With the low impedance settings, it's not critical that the setting matches the impedance of the connected load, but if it does, this will maximise the power that is available for the load.

The constant voltage settings specify the maximum RMS voltage that the amplifier will produce.

To choose the load matching, use the [Drive load on the Output menu \(page 23\)](#).

Rack ears

Rack ears (part number RACKKITC) provide rear support for iKON amplifiers installed in 19-inch racks. We recommend that you use rack ears for all rack mounted amplifiers, particularly for touring racks, where the vibration from movement can place unwanted stresses on the amplifier chassis if it is only supported at the front.

You can install the rack ears in two ways: removable or locked. Removable installation allows easy removal of the amplifier from the rack with no need for access to the rear:



With locked installation, you attach the amplifier to the rack at the rear, preventing removal from the front:

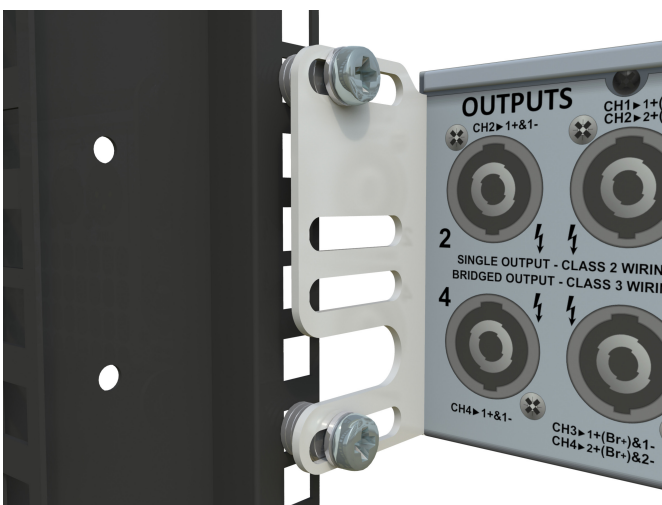

For removable installation, you attach amplifier brackets, attach rack brackets and then slot the two brackets together.

For locked installation, you attach amplifier brackets and then attach these brackets to the rear rack strip. With this method, you don't use the rack brackets.

Requirements

- The amplifier rack must have 19-inch rack strip at the front and rear. For removable installation, the depth between front and rear is relatively unimportant as the rack bracket allows for up to 180 mm of variation. For locked installation, the slots in the amplifier bracket allow up to 25 mm of variation.
- Four standard 19-inch rack cage nuts and fixing screws (most commonly M6 in Europe) to attach the brackets to the rear rack strip.
- A Pozidriv PZ1 screwdriver.
- A suitable screwdriver for the rack screws.
- A small pair of pliers or a 7 mm spanner.

To attach the amplifier brackets

1. Remove the two screws shown below. You can discard these screws.

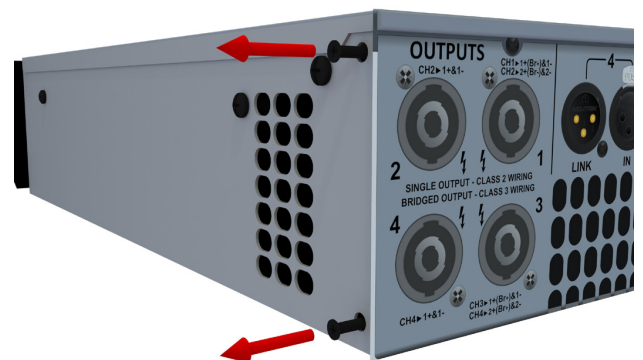

2. Attach the support bracket to the side panel using the screws and hex key supplied with the kit (M3 hex head screws and M2.5 hex key).



3. Attach the second amplifier bracket in the same way. You now either attach rack brackets (for removable installation) or attach the amplifier brackets to the rack strip (for locked installation).

To attach the rack brackets

1. Fit the amplifier in the rack using the front panel rack screws.
2. Temporarily hold one of the rack brackets on the rear rack strip so that the holes in the bracket line up with the slot in the amplifier bracket.
3. Make a note of the hole that is closest to the centre of the slot in the amplifier bracket.
4. Remove the amplifier from the rack.

5. Fit the nylon bush to the hole you identified in step 3. Use the M4x25 countersunk screw and M4 Nylok nut supplied with the kit.

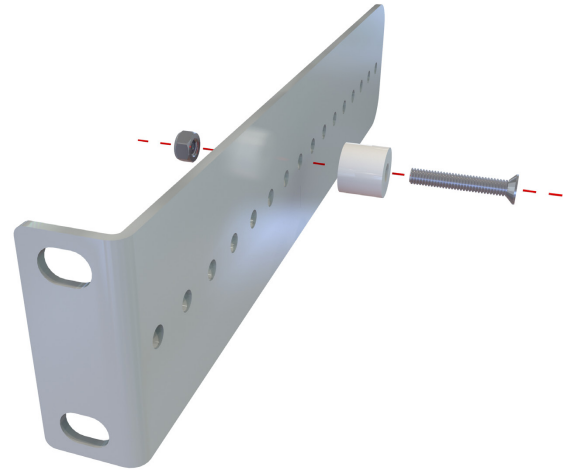

6. Fit the nylon bush to the same hole in the second bracket.
7. Fit two cage nuts onto the rear rack strip at the correct height to ensure that the rack brackets will engage with the amplifier brackets.
8. Attach each bracket with two rack screws.
9. Fit the amplifier in the rack and check that the amplifier bracket engages on the nylon bushes on both sides, supporting the weight of the amplifier at the rear.
10. Screw the amplifier to the rack using the four rack mount holes in the front panel.

To attach the amplifier brackets to the rack strip

1. Attach an amplifier bracket to the return on the rear rack strip, as shown in the picture near the start of this section. Use two standard rack cage nuts and screws. If there is a gap between the bracket and rack strip, use washers or spacers to close the gap; don't close the gap by tightening the rack screws so that the brackets bend.
2. Attach the second amplifier bracket in the same way.

AUX port

AUX X	AUX Y	2+Mute (event or state)	3 snaps (event or state)	4 snaps (state)	3+Mute (state)	2+Sleep (state)	Mute Slp (state)
Open	Open	No change	No change	Recall snap 1	Recall snap 1	No change	No change
Ground	Open	Recall snap 1	Recall snap 1	Recall snap 2	Recall snap 2	Recall snap 1	Mute
Open	Ground	Recall snap 2	Recall snap 2	Recall snap 3	Recall snap 3	Recall snap 2	Sleep
Ground	Ground	Mute	Recall snap 3	Recall snap 4	Mute	Sleep	Sleep

The AUX port allows you to send signals to the amplifier to:

- [Recall snapshots \(page 15\)](#). Note that the front panel screen shows the snapshot number.
- Mute and unmute all output channels. Note that all front panel output mutes will flash and continue to flash until you unmute.
- [Sleep \(page 30\)](#) and wake up.

The AUX port consists of the leftmost three pins of the six-pin Phoenix (Euroblock) connector on the [back panel \(page 11\)](#). From left to right, pin 1 is X, pin 2 is Y and pin 3 is ground (as labelled on the back panel). To trigger inputs X and Y you can:

- Connect the input to ground using a simple contact closure device (a relay or switch) with no need for an external voltage.
- **Or** – Send a logic signal to the input. The logic low must be less than +0.5V and the logic high must be less than +24V.

Example

1. Set the [style \(page 32\)](#) to **Mute Slp** (the rightmost column in the table above).
2. To mute all output channels, connect input X to ground (connect pin 1 to pin 3).
3. To unmute, disconnect X and ground (disconnect pin 1 and pin 3),
4. To sleep the amplifier, connect input Y to ground (connect pin 2 to pin 3).
5. To wake the amplifier, disconnect input Y and ground (disconnect pin 2 and pin 3).

AUX styles

You can configure the AUX port to respond in various styles, as summarised in the table above.

To select the style, use the [Aux style page of the Utility menu \(page 32\)](#).

The styles are:

- **None** – Ignore all signals.
- **2+Mute** (event or state) – To recall snapshot 1 or 2, apply a momentary or static connection to input X or Y. To mute the device, apply a static connection to both X and Y.
- **3 Snaps** (event or state) – To recall snapshot 1, 2 or 3, apply a momentary or static connection to inputs X and/or Y.
- **4 Snaps** (state) – To recall snapshot 1, 2, 3 or 4, apply a static connection to inputs X and/or Y.
- **3+Mute** (state) – To recall snapshot 1, 2 or 3, apply a static connection to input X or Y. To mute the device, apply a static connection to both X and Y.
- **2+Sleep** (state) – To recall snapshot 1 or 2, apply a static connection to input X or Y. Sleep the device by applying a static connection to both X and Y.
- **Mute Slp** (state) – Mute the device by applying a static connection to input X. Sleep the device by applying a static connection to AUX input Y.

Event or state

With the first two AUX styles (**2+Mute** and **3 snaps**) you can use events or states:

- With events, the signal is a momentary push-button or momentary relay contact closure.

- With states, the signal is a switch that holds the closure.

With the last four AUX styles (**4 snaps**, **3+Mute**, **2+Sleep**, **Mute Slp**), you can only use states. With these AUX styles, a selected snapshot is only held while the connection continues.



If the connection pattern is static, the snapshot recall overrides both [Vu-Net \(page 36\)](#) and the front panel menu.

Q-SYS plugin

Our **Q-SYS plugin** allows you to control and monitor iKON amplifiers from a Q-SYS controller.

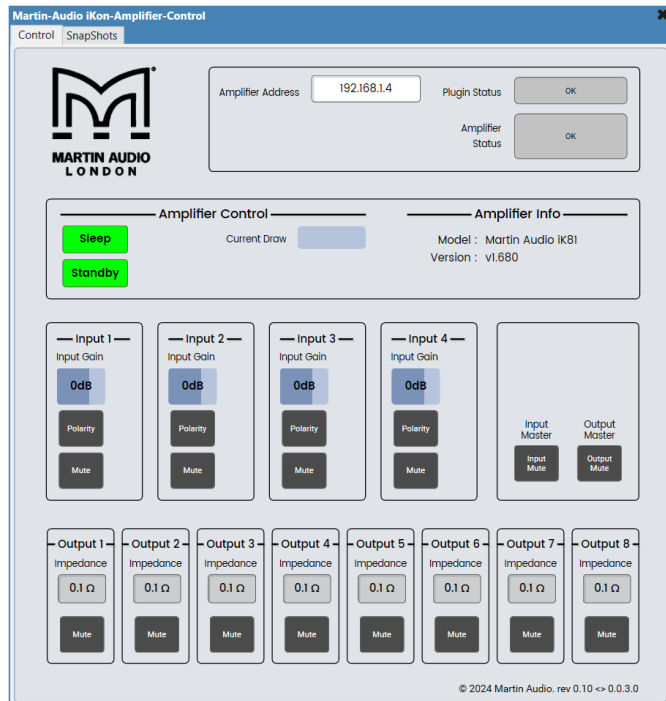

The plugin is available as a free download from our website and allows you to:

- Mute and unmute inputs.
- Update input gain and polarity.
- Mute and unmute outputs.
- Put the amplifier into sleep or standby mode.
- Bring the amplifier out of sleep or standby mode.
- Check whether the amplifier is on or off.
- Check the firmware version.
- Recall amplifier snapshots.

To download the Q-SYS plugin

1. Visit our website www.martin-audio.com.
2. Select **Support > Software/Firmware** and scroll to the section **Q-SYS plugin**.
3. Click **DOWNLOAD Q-SYS PLUGIN**.

To download the Q-SYS plugin user guide

1. Visit our website www.martin-audio.com.
2. Select **Support > Software/Firmware** and scroll to the section **Q-SYS plugin**.
3. Click **USER GUIDE**.

Tipi control

Tipi is a text-based protocol that allows you to control and monitor iKON amplifiers over Ethernet using third-party control panels or software applications. For example, our [Q-SYS plugin \(page 45\)](#) uses Tipi commands.

Tipi specification

- Tipi uses Ethernet (10/100/1G) with TCP/IP protocol and port 51456.
- Messages are text strings (8-bit ASCII) of up to 255 characters.
- Messages start with a `$` character.
- Messages end with a carriage return character (`<CR>`, `\r`, ASCII 13, hexadecimal 0x0D).
- Fields are separated by one or more space characters.
- Numbers are expressed in decimal units.
- Tipi isn't case sensitive, so you can use any combination of upper and lower case. For example, all of the following are valid commands to mute input A:

```
$SET INA/MUTE YES
$SET inA/Mute Yes
$set ina/mute yes
```

The response messages are upper case, except for the parameter values.

Tipi message format

The message format is:

```
$C M V E
```

Where:

- `$` is the start character.
- `C` is the command: `get`, `set` or `nop`. You mustn't put a space between the `$` and the command.
- `M` is the method name. For example:

```
$get ina/meter
```

This command uses method `ina/mute` to request the mute status for input A.

- For inputs A to D, use `ina` to `ind`
- For outputs 1 to 4, use `out1` to `out4`

Note that the iK81 has outputs 1 to 8, so you can use `out1` to `out8`

Some commands are only for inputs (such as `set ina/gain`) and some commands are only for outputs (such as `get out1/imp`).

- `V` is the value, for example `-3.5dB`. Note that you can omit the unit of measure, for example:

```
$set inc/gain -3.5
```

This sets the gain for input C to `-3.5 dB`.

- `E` is the end delimiter `<CR>`

Commands

- `set` tells the amplifier to set the specified parameter to a particular value. For example:

```
$set out2/mute yes
```

This command mutes output 2.

- `get` requests the value of a parameter. The amplifier returns a `NOTIFY` message with the value requested. For example:

```
$get out3/mute
```

This requests the mute setting for output 3. If this output is unmuted, the response is:

```
$NOTIFY OUT3/MUTE no
```

As parameter values are quantised in the device, the value returned to a `get` command may not be exactly the same as the value used in the `set` command. For example:

```
$set ina/gain 3.15
$get ina/gain
```

Response:

```
$NOTIFY INA/GAIN 3.2dB
```

The amplifier has rounded the gain from 3.15 dB to 3.2 dB.

- `nop` keeps the session alive. There are no parameters for `nop` so the whole command is:

```
$nop
```

The session timeout is 120 seconds, so sending a `nop` command every 60 seconds works well.

For the list of Tipi commands, see [Tipi commands \(page 50\)](#).

Responses

- If a `set` or `nop` command is successful, there is no response.
- If a `get` command is successful, the response is a `NOTIFY` message. For example:

```
$get inc/gain
```

Response:

```
$NOTIFY INC/GAIN 2.0dB
```

- If a `set` or `get` command is incorrect, the response is an error message. The format is:

```
$ERROR [number] [description]
[incorrect message]
```

For example:

```
$get out1/gain
```

Response:

```
$ERROR 12 UnknownMethod $get out1/gain
```

This example command returns this error because you can't view or change the output gain with Tipi (though you can view and change the input gain).

For a list of example responses, see [Tipi commands \(page 50\)](#).

Error codes

If the command is incorrect, the `$ERROR` response includes an error code between 01 and 12:

01, 02, 03, 04	Bad command - incomplete
05	Bad command - unexpected length
06	Bad command
07	Bad command - param value
08	Unknown method
09	Unknown method type
10	Bad command - expected yes or no
11	Bad command - float format
12	Unknown method

Fault codes

If you use the command `$get alarms/worst` and the worst alarm is a fault, the number at the end of the response is a positive number:

14	Fan fault
15	PSU power fault
16	VHF fault
17	Driver current fault
18	Mains voltage fault
19	Temperature fault
20	HT fault
21	PSU shutdown fault
22	DC fault
23	Starting fault

Incident codes

If you use the command `$get alarms/worst` and the worst alarm is an incident, the number at the end of the response is negative number:

-1	PSU current needs attention
-2	Channel 1 impedance needs attention
-3	Channel 2 impedance needs attention
-4	Channel 3 impedance needs attention
-5	Channel 4 impedance needs attention
-6	Channel 5 impedance needs attention
-7	Channel 6 impedance needs attention
-8	Channel 7 impedance needs attention
-9	Channel 8 impedance needs attention
-10	Slow fan needs attention
-11	PSU power needs attention
-12	Temperature needs attention
-13	Startup needs attention

Tipi testing

You can test Tipi commands using a terminal emulator. As an example, the instructions below show you how to test Tipi using **Tera Term**, which is a free open-source terminal emulator that you can download from github or various other websites.

To test Tipi using Tera Term

1. Download and install **Tera Term**.
2. Start **Tera Term**.
3. In the **Host** field, enter the **IP address (page 33)** of the amplifier.
4. In the **TCP port#** field, enter 51456.
5. In **Service**, select **Other**.
6. Click OK.
7. Select **Setup > Terminal**.
8. In the **New-line** section set **Receive** to **CR+LF**.
9. Tick **Local echo**.
10. Click OK.
11. Start typing commands, such as the examples below.

Example commands

The following example commands find out the firmware version, then mute and unmute input A and output 1. The `$get` commands check the mute status before and after each change, allowing you to see the change in status. Note that the `$set` commands don't return a message unless an error occurs.

```
$get version
$get ina/mute
$set ina/mute yes
$get ina/mute
$set ina/mute no
$get ina/mute
$get out1/mute
$set out1/mute yes
$get out1/mute
$set out1/mute no
$get out1/mute
```

Example responses

If input A and output 1 start off unmuted, the responses to the above commands should look like this (with firmware 1.680):

```
$NOTIFY VERSION 1680
$NOTIFY INA/MUTE no
$NOTIFY INA/MUTE yes
$NOTIFY INA/MUTE no
$NOTIFY OUT1/MUTE no
$NOTIFY OUT1/MUTE yes
$NOTIFY OUT1/MUTE no
```

Tipi commands

The following table shows the full list of Tipi commands supported by iKON amplifiers.

Command	Example	Response
View input mute	<code>\$get inb/mute</code> This example requests the mute status of input B.	<code>\$NOTIFY INB/MUTE yes</code> This example shows that input B is muted <code>\$NOTIFY IND/MUTE no</code> This example shows that input D is unmuted
Update input mute	<code>\$set inb/mute yes</code> This example mutes input B <code>\$set ina/mute no</code> This example unmutes input A	There is no response to this command
View input gain	<code>\$get ina/gain</code> This example requests the gain for input A	<code>\$NOTIFY INA/GAIN 1.0dB</code> This example shows that the gain for input A is 1 dB The response ends with the gain (–40 dB to 20 dB)
Update input gain Note that you can't view or update output gain (Tipi isn't designed for tuning the system)	<code>\$set ina/gain -3.2</code> This example sets the input A gain to –3.2 dB The gain can be –40 dB to 20 dB	There is no response to this command
View input polarity (page 17)	<code>\$get ind/pol</code> This example checks the polarity of input D	<code>\$NOTIFY IND/POL yes</code> This example shows that input D has reversed polarity <code>\$NOTIFY INC/POL no</code> This example shows that input C has normal polarity
Update input polarity (page 17)	<code>\$set inc/pol yes</code> This example sets input C polarity to reversed <code>\$set inb/pol no</code> This example sets input B polarity to normal	There is no response to this command
View output mute	<code>\$get out2/mute</code> This example checks the mute status of output 2	<code>\$NOTIFY OUT2/MUTE yes</code> This example shows that output 2 is muted <code>\$NOTIFY OUT4/MUTE no</code> This example shows that output 4 is unmuted
Update output mute	<code>\$set out3/mute yes</code> This example mutes output 3 <code>\$set out4/mute no</code> This example unmutes output 4	There is no response to this command
Change snapshot (page 15)	<code>\$set snapshot 5</code> This example recalls snapshot 5 The snapshot can be 1 to 20	There is no response to this command
View sleep status (page 30)	<code>\$get sleep</code>	<code>\$NOTIFY SLEEP no</code> This example shows that the amplifier is not sleeping <code>\$NOTIFY SLEEP yes</code> This example shows that the amplifier is sleeping
Change sleep status (page 30)	<code>\$set sleep yes</code> This example puts the amplifier to sleep <code>\$set sleep no</code> This example wakes the amplifier up	There is no response to this command

Command	Example	Response
View standby status (page 30)	<code>\$get standby</code>	<code>\$NOTIFY STANDBY yes</code> This example shows that the amplifier is in standby <code>\$NOTIFY STANDBY no</code> This example shows that the amplifier is not in standby
Change standby status (page 30)	<code>\$set standby yes</code> This example puts the amplifier into standby <code>\$set standby no</code> This example brings the amplifier out of standby	There is no response to this command
View worst alarm This requests the worst error code currently detected by the amplifier. For example, if there is an incident and a fault, the response will just show the fault	<code>\$get alarms/worst</code>	<code>\$NOTIFY ALARMS/WORST -6</code> This example shows that the worst alarm is minus 6 0 means no errors Negative means the worst alarm is an incident. See Incident codes (page 48) Positive means the worst alarm is a fault. See Fault codes (page 47)
View input meter	<code>\$get ina/meter</code> This example checks the meter for input A	<code>\$NOTIFY INA/METER 1.2dB</code> This example shows that the input A meter is currently 1.2 dB
View output meter	<code>\$get out2/meter</code> This example checks the meter for output 2	<code>\$NOTIFY OUT2/METER 5.1dB</code> This example shows that the output 2 meter is currently 5.1 dB
View driver impedance (page 23)	<code>\$get out3/imp</code> This example checks the impedance for output 3	<code>\$NOTIFY OUT3/IMP 4.2R</code> This example shows that the impedance for output 3 is 4.2 ohm 0.1R or a value over 100 means un-determined
View output channel current draw	<code>\$get amp1/current</code> This example checks the current draw of output 1 Note the wording is <code>amp</code> rather than <code>out</code>	<code>\$NOTIFY AMP1/CURRENT 2.3A</code> This example shows that output 1 current draw is 2.3 A
View amplifier current draw	<code>\$get drawcurrent</code>	<code>\$NOTIFY DRAWCURRENT 11A</code> This example shows that the amplifier current draw is 11 A
View firmware type	<code>\$get type</code>	<code>\$NOTIFY TYPE 3520</code> The response shows the version number multiplied by a thousand. So, this example shows that the firmware type is 3.520
View Firmware version (page 29)	<code>\$get version</code>	<code>\$NOTIFY VERSION 1680</code> The response shows the version number multiplied by a thousand. So, this example shows that the firmware version is 1.680
Keep the session alive The session timeout is 120 seconds, so you need to send <code>\$nop</code> command more frequently than this (60 seconds works well)	<code>\$nop</code>	There is no response to this command

Latency delay

Digital Signal Processing and conversion between different formats of signal (analogue, digital, network and so on) introduces some delay (latency) to the signal path. Of course, we strive to minimise these latencies. The following tables show the principal latencies introduced by the device.

Input latency

Analogue input	0.385 ms
Or digital input at 96 KHz sample rate	0.5 ms
Or digital input at 48 KHz sample rate	0.66 ms

Output latency

Analogue output	0.402 ms
Or AES3 output	0.1 ms
Or Dante output (excluding Dante network latency)	1.29 ms @ 44.1 kHz
	0.68 ms @ 48 kHz
	0.45 ms @ 96 kHz

Processing latency

Unless you're using LIR crossover filters or FIR high shelf EQs, the processing latency is always 1.57 ms. So to calculate total latency, you normally just add 1.57 ms to the input and output delays.

If you're using LIR or FIR, the processing latency calculations are shown in the table below. Note that the processing latency can be more than 1.57 ms. When high pass frequency is set below 40 Hz the filter will automatically revert to Linkwitz-Riley; this is set so that the latency will not exceed 30 ms.

Input HiShelf FIR	0.4 ms (0 ms if set to 'Off')
LIR crossover filter	1.19 ms / crossover high pass frequency in kHz, limited to 30 ms maximum
VxLim Limiter (VX mode off)	0.12 ms / crossover high pass frequency in kHz, limited to 1.57 ms maximum
Or VxLim Limiter (VX mode on)	0.358 ms / Vx split frequency in kHz, limited to 1.57 ms maximum

If you're using input FIR filters, LIR filters or VX Limiters, it's best to view the Drive Module latency on the front panel rather than calculating the value. For details, see [Drive module latency \(page 20\)](#).

Example latency calculation

Analogue input	0.385 ms
Analogue output	0.402 ms
Input high shelf FIR (off)	0 ms
LIR crossover (500 Hz)	2.380 ms
VxLim Lim (VX mode on, Vx split frequency 1 kHz)	0.358 ms
Total	3.525 ms

Note that the latencies within a Drive Module are equalised among outputs of that Drive Module. That is, the device automatically adds padding delay to some outputs so that the total latency is the same for each output of a Drive Module.

This latency equalisation does not extend outside a Drive Module, so Drive Modules are not guaranteed to have the same latency as one another.

Protection systems

Comprehensive protection features preserve the longevity of the loudspeaker and amplifier by continuously monitoring critical parameters, and reducing the gain, or muting the amplifier either temporarily or more permanently depending on the nature and seriousness of the fault or misuse. The amplifier will recover and restart if at all possible but may remain in shut down if a serious fault persists.

Limiters deal with routine over-driving of the amplifier, making sure that the drivers aren't pushed too hard. The limiter indicators will warn you when the driver is being driven into limit.

Minor faults are dealt with by 'dimming' the amplifier, reducing the level to a sufficient degree and for a sufficient time that the amplifier is able to recover gracefully without any user interaction. When the fault condition has passed, the amplifier will recover automatically.

When the protection systems are reducing the level, this is indicated by illuminating the left-hand amplifier channel protection indicator. This will also illuminate when the output voltage is 'clipping'. This indicator will remain permanently illuminated if the channel has been muted by the protection systems. In addition, the mute button will flash and there will usually be a warning message on the display. Some types of protection affect all output channels and in this case, all output mute buttons will flash.

Summary of protection indication

The protection indicators illuminate for the following reasons:

Amplifier indicator	Driver indicator	Notes
	Limiter 6dB over	
	Thermal limiting	
	Excursion limiting	
Amplifier clipping		
Amplifier clip limiting		
Amplifier current limiting		
Amplifier VHF limiting		
PSU current limiting		Will show on all output channels
PSU power limiting		Will show on all output channels

Amplifier indicator	Driver indicator	Notes
Thermal limiting		Will show on all output channels

Fault relay port

The fault relay port allows you to monitor for amplifier faults using an external system such as Q-SYS or Crestron. The fault relay port consists of the three pins on the right of the six-pin Phoenix connector (also known as a Euroblock) on the [back panel \(page 11\)](#). With the six pins numbered from left to right, the fault relay port is pins 4, 5 and 6.

When the amplifier is off, the relay is idle so that pin 4 connects to pin 5. This is shown on the diagram printed below the connector on the [back panel \(page 11\)](#). When the amplifier is switched on, the relay energises so that pin 4 connects to pin 6. If a fault occurs, the relay de-energises so that pin 4 connects to pin 5. So, if pin 4 is connected to pin 5, this means either fault or amplifier off.

You can choose whether the fault relay port shows faults only or faults and warnings. To configure this, see [Alarm \(page 31\)](#). If you choose to monitor for faults and warnings, the relay de-energises when faults occur, when warnings occur and when the amplifier is off. So, if pin 4 is connected to pin 5, this means fault, warning or amplifier off.

Signal path

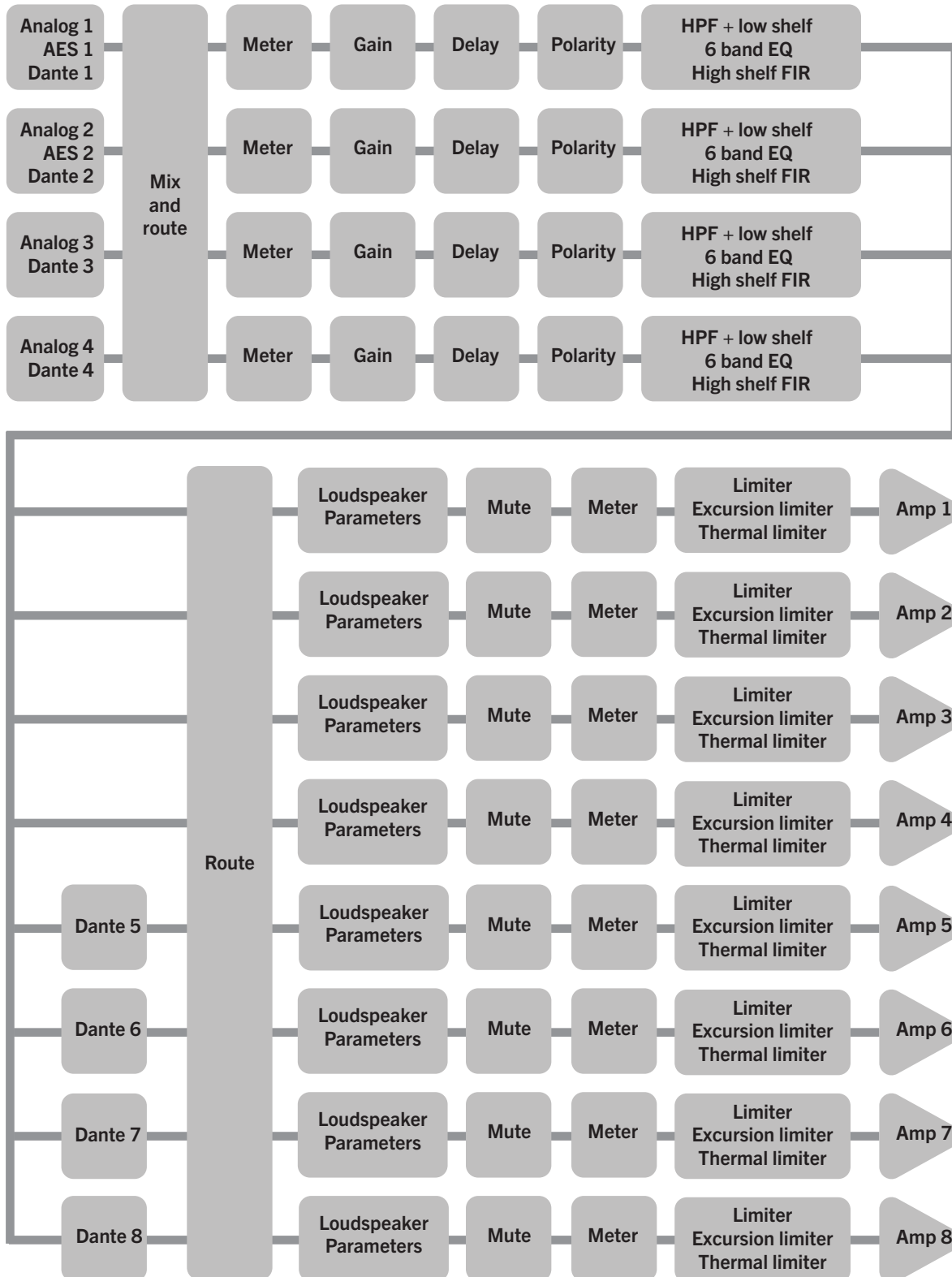

EQ and filter response graphs

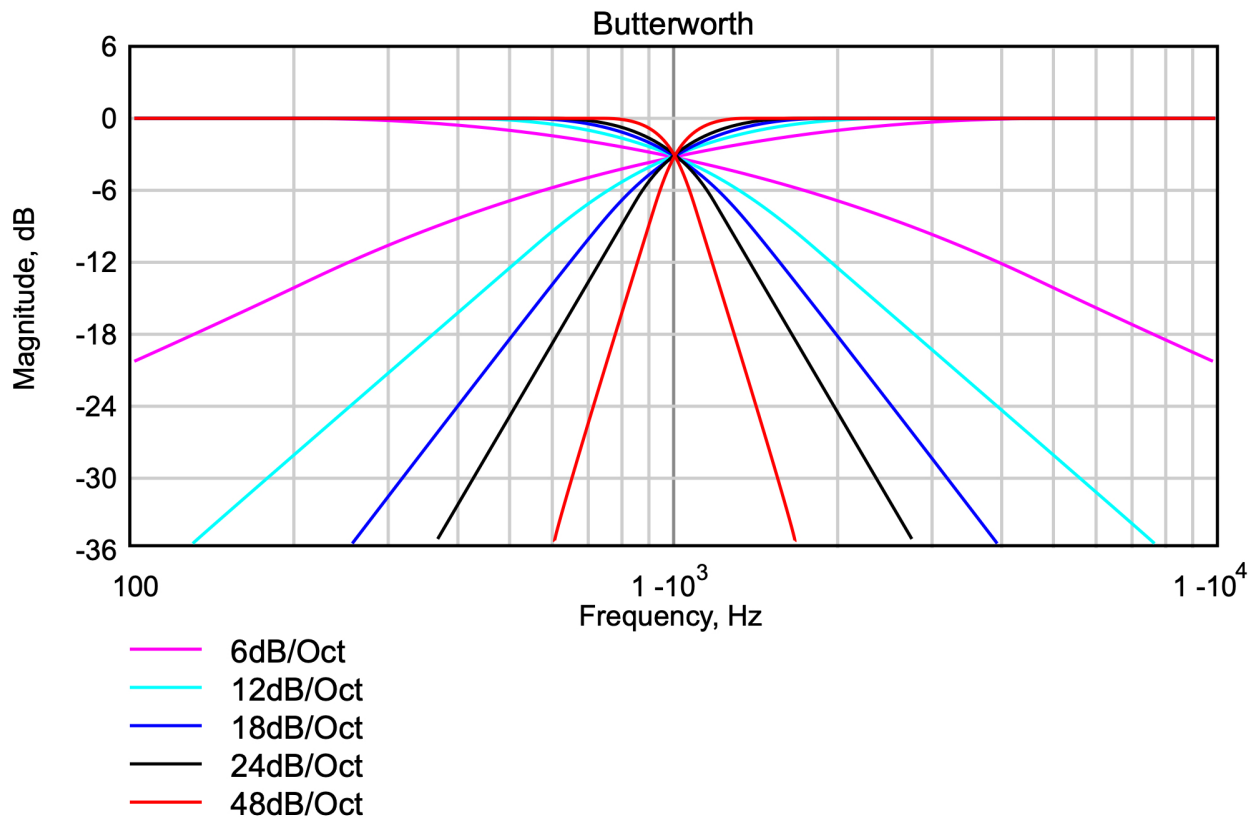

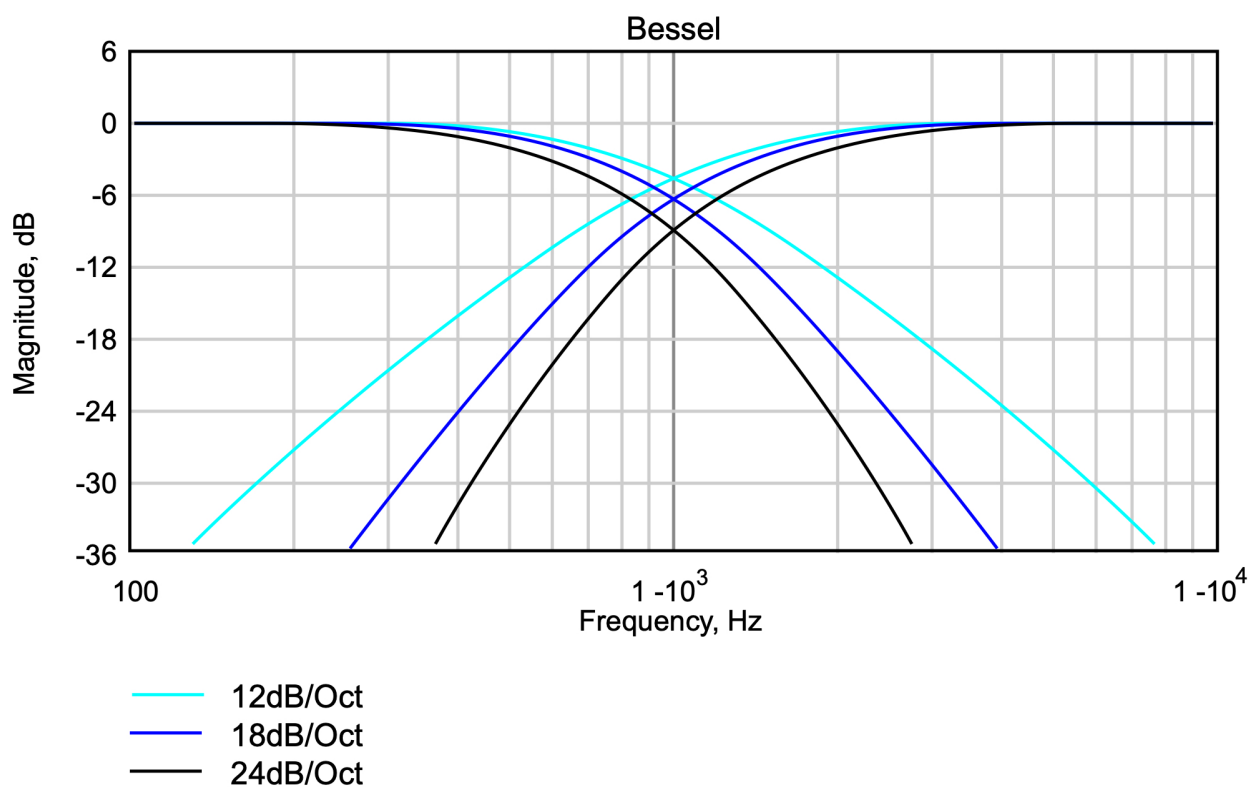
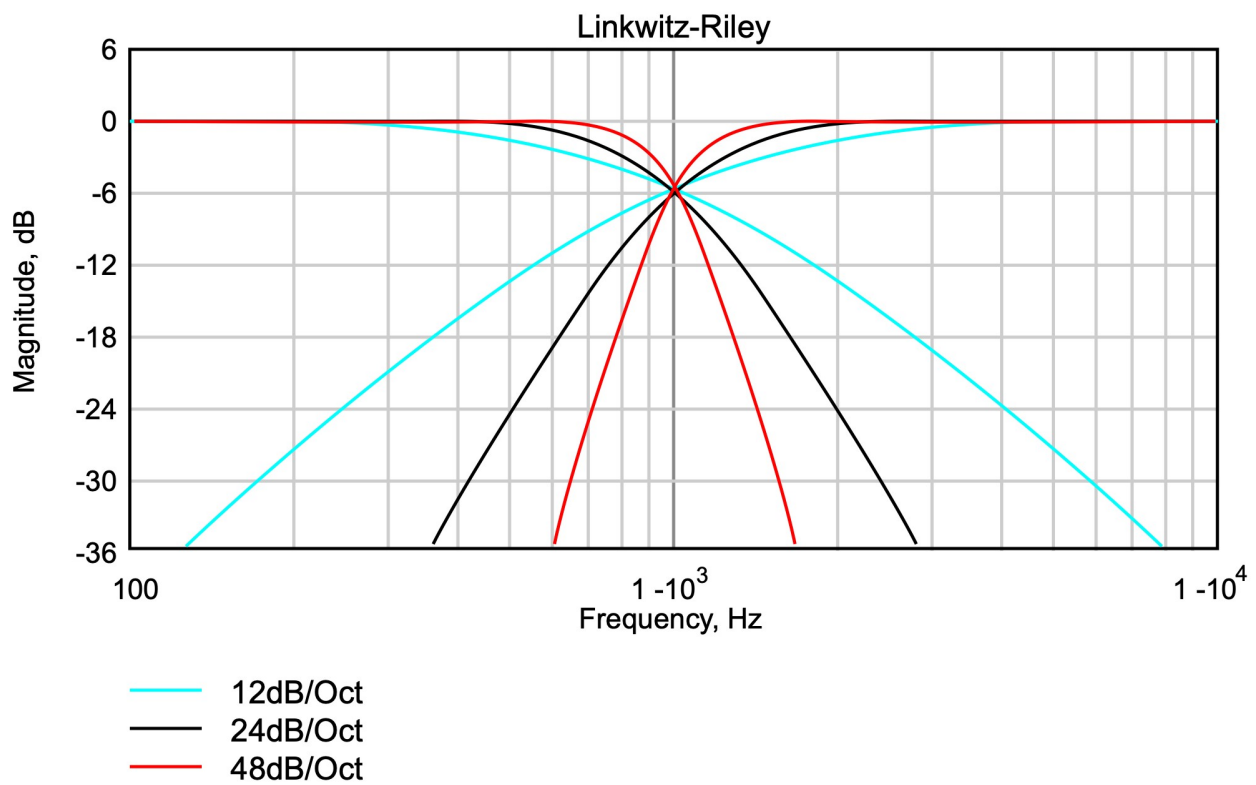

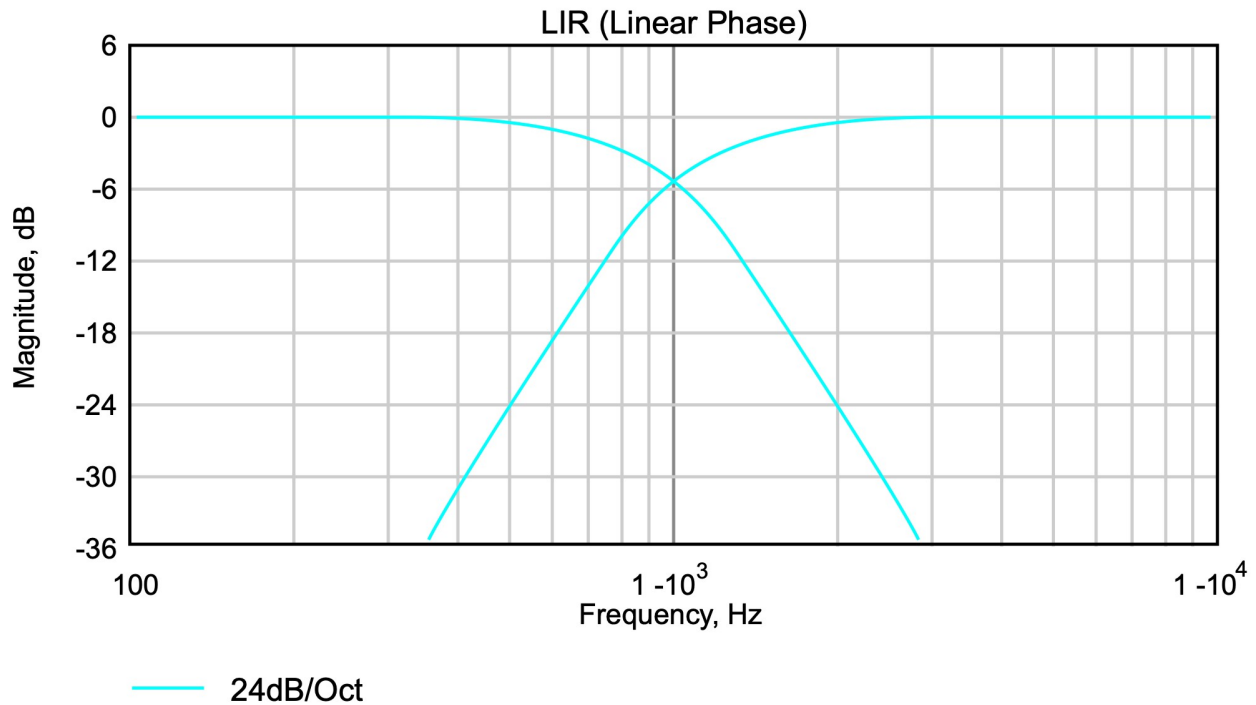
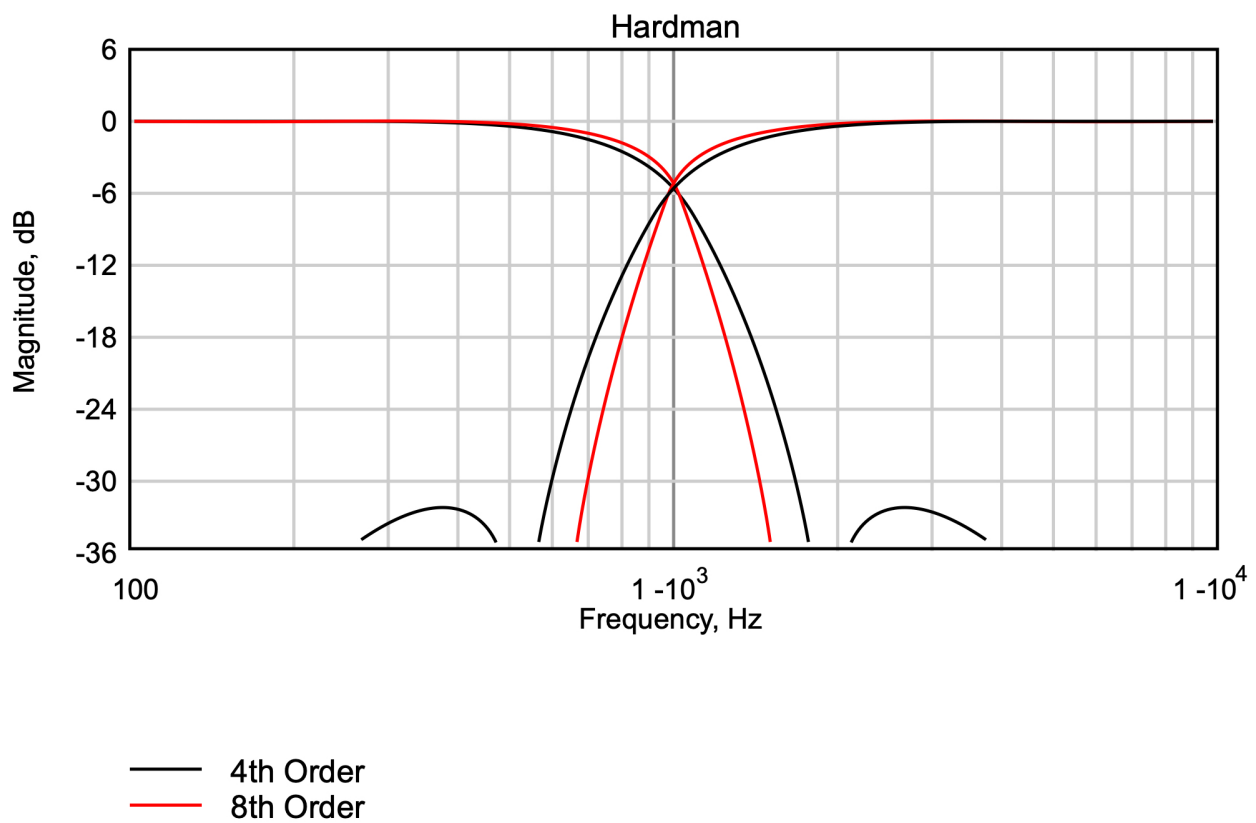

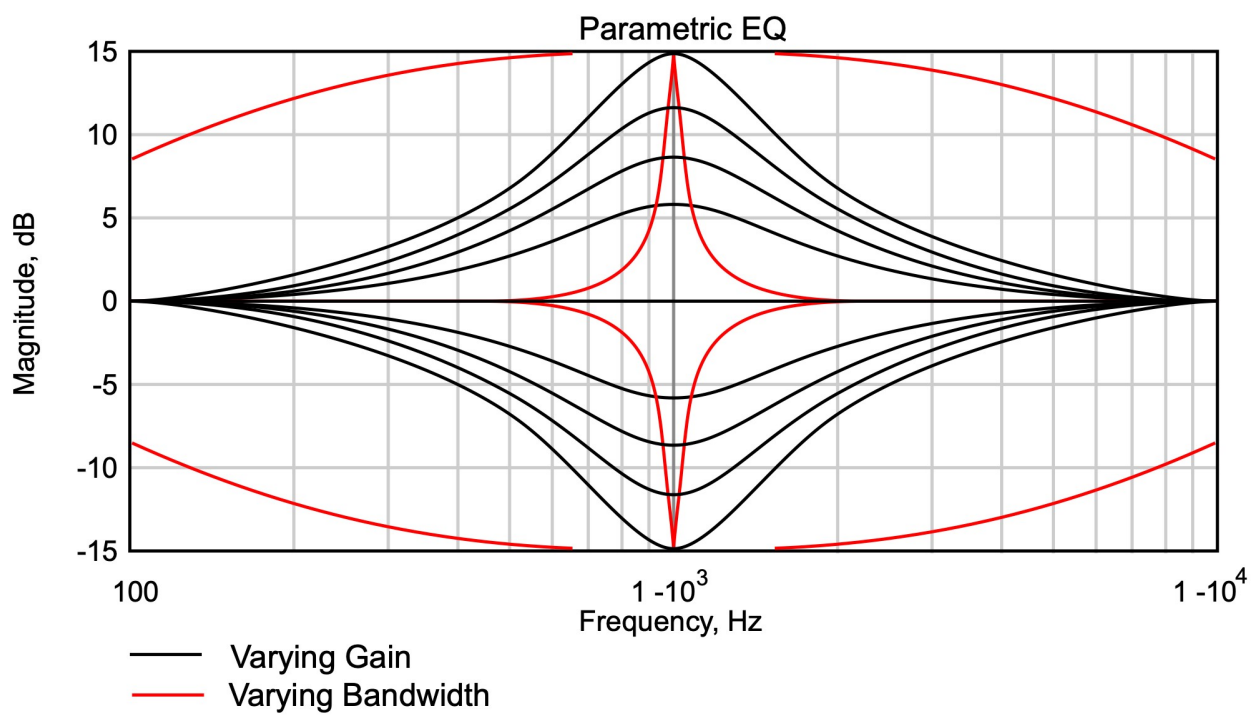
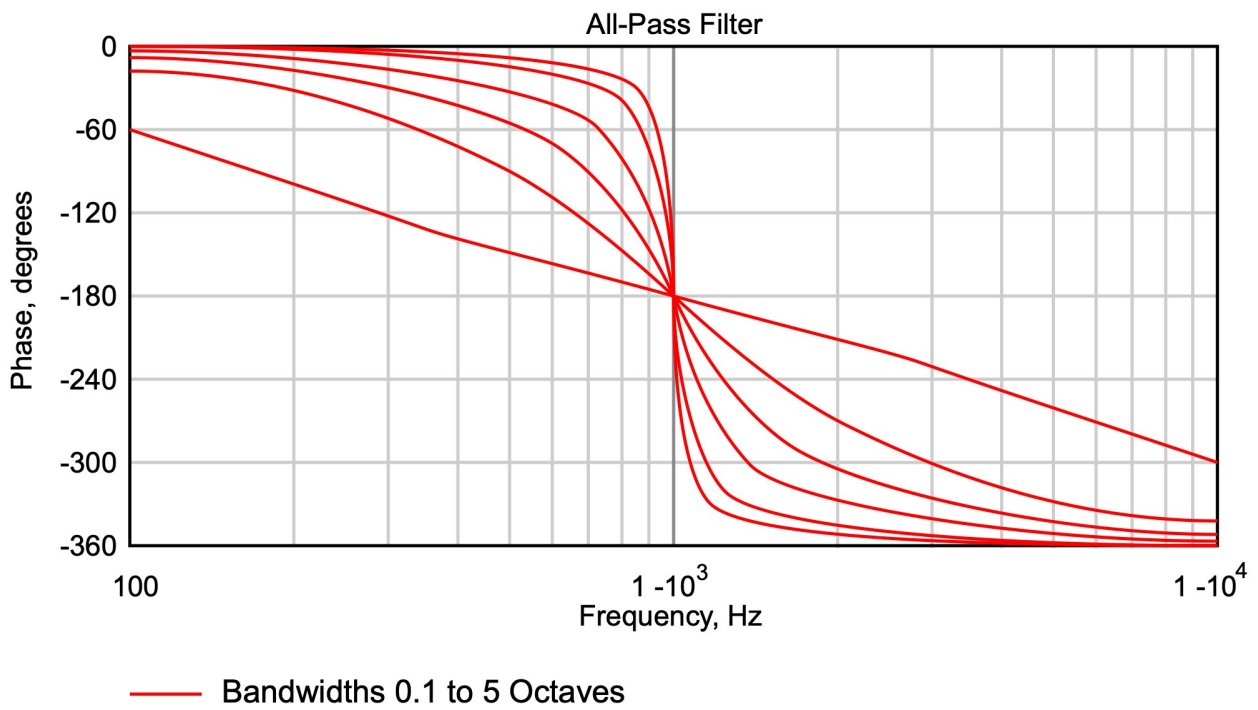

Power draw and thermal dissipation

Sleep mode (slow wake up)					
AC Mains Power Draw (watts)	Current Draw (amps)		Thermal Dissipation		
	120 Vac	230 Vac	watts	kcal/hr	Btu/hr
4.5	0.4	0.2	4.5	4	15

Standby mode (fast wake up)					
AC Mains Power Draw (watts)	Current Draw (amps)		Thermal Dissipation		
	120 Vac	230 Vac	watts	kcal/hr	Btu/hr
60	1.0	0.5	60	52	205

Running with no audio signal					
AC Mains Power Draw (watts)	Current Draw (amps)		Thermal Dissipation		
	120 Vac	230 Vac	watts	kcal/hr	Btu/hr
204	3	1.55	204	175	696

Running (all channels driven)								
Load mode	Load	Signal duty and Crest Factor	Input power (watts)	Current Draw		Thermal Dissipation		
				(amps)		watts	kcal/hr	Btu/hr
				120 Vac	230 Vac			
2 ohm	2 ohm	1/8, cf = 4.0 (12 dB)	1,703	20.4	10.6	453	390	1,547
2 ohm	4 ohm	1/4, cf = 2.8 (9 dB)	1,652	19.8	10.3	402	345	1,371
2 ohm	4 ohm	1/8, cf = 4.0 (12 dB)	938	11.9	6.2	313	269	1,069
4 ohm	4 ohm	1/4, cf = 2.8 (9 dB)	2,967	31.6	16.5	467	401	1,592
4 ohm	4 ohm	1/8, cf = 4.0 (12 dB)	1,617	20	10.4	367	315	1,251
4 ohm	8 ohm	1/4, cf = 2.8 (9 dB)	1,605	19.2	10.0	355	305	1,211
4 ohm	8 ohm	1/8, cf = 4.0 (12 dB)	920	16.6	6.1	295	254	1,007
8 ohm	8 ohm	1/4, cf = 2.8 (9 dB)	2,825	33.1	17.3	325	279	1,109
8 ohm	8 ohm	1/8, cf = 4.0 (12 dB)	1,567	18.48	9.6	317	272	1,081
100V	–	1/8, cf = 4.0 (12 dB)	1,551	18.3	9.5	301	259	1,026
70V	–	1/8, cf = 4.0 (12 dB)	1,601	19.8	10.3	351	302	1,197
25V	–	1/8, cf = 4.0 (12 dB)	946	12	6.3	321	276	1,094

- Measurements done using a Hameg HM8115-2 power analyser
- Amplifier configured to have no audio processing
- All measurements done at 230 Vac, 50 Hz
- Current Draw values for 120 Vac are calculated values

Technical specifications

General	
Number of output channels	Eight
Total power output	10,000 watts RMS, depending on load impedance
Input types	<ul style="list-style-type: none"> ■ Analogue – four channels ■ AES3 – two channels ■ Dante (AES67 compatible) – eight channels (four inputs routable to four input DSP, four inputs routable to four output DSP) (page 16)
Control, monitoring & alarm	Ethernet, configurable function Volt-free relay and contact closure port
Energy saving modes	Standby and deep sleep, both with auto-sleep timers
System sleep and wakeup	Front panel switch, network command, contact closure and audio detection
Max ambient temperature (full power, no limiting)	40°C (104°F)

Audio	
Amplifier topology	Proprietary 5th generation Martin Audio Class D
Amplifier modulation scheme	Low feedback, multiple loop, with feedforward error correction
Dynamic range (analogue input to speaker output)	>113 dBA typically
Dynamic range (AES3 or Dante input to output)	>114 dBA typically
Gain (with all DSP level controls set to 0 dB)	32 dB
Frequency response	<7 Hz to >30 kHz, 4 ohm, –2.5 dB
Total harmonic distortion (THD)	<0.05% typically, 1 kHz, AES17, 4 ohm load
Inter-channel crosstalk (worst combination of channels)	Better than –85 dB at 1 kHz and –75 dB at 10 kHz
Slew Rate	>60 V per microsecond typical
Damping factor (Ref 8 ohm)	>800 at amplifier output
Maximum analogue input level	+20 dBu
Analogue input sensitivity range for full output	0 dBu to +20 dBu, continuously adjustable
Analogue input	20,000 ohm, electronically balanced
Analogue link	Directly connected to the analogue input
Analogue ground scheme	AES48 standard compliant
AES3 input	Transformer isolated with active cable equalisation for extended range
AES3 link	Active signal regeneration with automatic direct bypass to the AES3 input if the unit is unpowered

Audio	
AES3 supported sampling rates	24 kHz to 192 kHz (auto locking)

Digital processing	
Resolution	40 bit, using proprietary Linea Micro Detail (LMD) algorithms
Sample rate	96 kHz throughout
Special functionality:	<p>Class leading limiter suite (page 53)</p> <p>Hardman crossover filters (better out of band rejection than Linkwitz-Riley)</p> <p>LIR crossover filters (Linear Phase without the compromises of FIR filters)</p> <p>FIR Shelving EQ filters (for linear phase filtering)</p>

Power output	
Power specification	RMS output power per channel, all channels driven with continuous program material and a nominal ambient temperature of 40°C (105°F)
	1,250 W into 2 ohm
	1,250 W into 4 ohm
	1,250 W into 8 ohm
	625 W into 16 ohm
	2,500 W bridged per channel pair, 4 ohm
	2,500 W bridged per channel pair, 8 ohm
CV line output	625 W, 25 V line
	1,250 W, 70 V line
	1,250 W, 100 V line

Power supply	
Topology (main power supply)	3rd generation Series Resonant
Topology (auxiliary and standby supplies)	Low quiescent Eco-Flyback
Internally stored energy	>600 joules
Mains input voltage range (automatically configured)	100-120 V range thresholds 75-138 V
	220-240 V range thresholds 138-275 V
Mains input frequency range	47 Hz to 63 Hz
Mains inrush current (max for <10 ms)	6 A at 100-120 V 12 A at 220-240 V

Physical	
Cooling	Variable speed fans
Airflow	Front to back
Air filtration	Washable media, changeable without the use of tools
Analogue IN and LINK connectors	4 x Genuine Neutrik™ XLR for IN 4 x Genuine Neutrik™ XLR for LINK Analogue – four channels
AES3 IN and LINK connectors	1 x Genuine Neutrik™ XLR for IN 1 x Genuine Neutrik™ XLR for LINK AES – two channels
Audio output connector	4 x Genuine Neutrik™ speakON Output audio – eight channels (two channels per connector)
Mains input connector	1 x Genuine Neutrik™ 32A powerCON chassis connector 1 x powerCON cable connector supplied (page 38)
Dante	2 x Shielded RJ45 (one primary and one secondary) Dante (AES67 compatible) – eight channels (four inputs routable to four input DSP, four inputs routable to four output DSP) (page 16)
Relay output and contact closure inputs	Six-pin Phoenix pluggable terminal block for: <ul style="list-style-type: none"> ■ AUX port (page 43) ■ Fault relay (page 53)
Front panel display	Graphical, backlit, high contrast, daylight visible
Front panel encoders	Two, indented, velocity sensitive
Front panel push buttons	Large, tactile, illuminated
LED indicators	Bright, easily differentiated
Enclosure	Standard 19-inch 2U (88 mm) with handles and optional rear support (page 41)
Depth (behind rack ears)	357 mm (14 inch)
Net Weight	12.5 kg (27.5 pounds)

Options

Rear rack ears (page 41) (rear support for iKON amplifiers installed in 19-inch racks)	Part number RACKKITC
--	----------------------

Protection systems

System protection

The control and protection systems aim to deliver the maximum power possible for the current conditions, applying limiters only in extreme circumstances

Muting only occurs when the amplifier detects a dangerous situation. When the condition clears, normal operation automatically resumes

Detect excessive output current

Detect excessive power supply current

Detect excessive amplifier section temperature

Detect excessive power supply section temperature

System protection

Detect excessive DSP section temperature

Detect mains voltage out of range

Detect fan speeds out of range

Detect internal power rails out of range

Speaker protection

Audio soft-clip limiter

VxLim, Multiband peak limiter

VxMax, Multiband overshoot limiter

Vx-Xmax, Driver excursion limiter

Vx-Tmax, Driver thermal limiter (long term power limiter)

DC offset protection

Excessive HF energy (VHF) limiter

Power distribution protection systems

Mains inrush current limiting (soft start and anti-surge)

Mains average current limiting (mains breaker / fuse trip protection)

Randomised initialisation when powered up to reduce the peak power demand in large systems

Monitoring and logging

You can configure the inbuilt alarm and notification system to indicate problems to remote devices either via Ethernet or the [fault relay port \(page 53\)](#)

Supply current logged vs time

Supply voltage logged vs time

Thermal Capacity logged vs time

Each driver current logged vs time

Each driver impedance logged vs time

Protection limiting for each output logged vs time

Number of power cycles counted

Number of mains brownout events counted

Fan speeds continuously monitored

Fan under-speed events counted

Various protection mute events counted

Driver Impedance continuously monitored

iK81 loudspeaker compatibility

The following table shows the compatibility of the iK81 with core Martin Audio loudspeakers. For explanation, see the [Amplifier compatibility legend \(page 63\)](#).

		Channels	Impedance	16 Ω	8 Ω	4 Ω	2 Ω	8 Ω Bridged	4 Ω Bridged
				625 W	1,250 W	1,250 W	1,250 W	2,500 W	2,500 W
CDD	CDD5	1	8	NA	Yes	Yes	Yes	NN	NN
	CDD6	1	8	NA	Yes	Yes	Yes	NN	NN
	CDD8	1	8	NA	Yes	Yes	-1.1 dB	NN	NN
	CDD10	1	8	NA	Yes	Yes	-2.0 dB	NN	NN
	CDD12	1	8	NA	Yes	Yes	-2.8 dB	NN	NN
	CDD15	1	8	NA	Yes	-1.1 dB	No	NN	Yes
FlexPoint	FP4	1	16	Yes	Yes	Yes	Yes	NN	NN
	FP6	1	16	Yes	Yes	Yes	-2.8 dB	NN	NN
	FP8	1	8	NA	Yes	Yes	-2.0 dB	NN	NN
	FP12	1	8	NA	Yes	-0.5 dB	No	NN	Yes
	FP15	1	8	NA	Yes	-2.0 dB	No	NN	Yes
LE monitors	LE100	1	8	NA	Yes	Yes	-2.8 dB	NN	NN
	LE200	1 or 2	8	NA	Yes	-1.1 dB	No	NN	Yes
O-LINE	O-LINE	1	16	Yes	Yes	Yes	Yes	NN	NN
SX subwoofers	SX110	1	8	NA	Yes	Yes	-1.1 dB	NN	NN
	SX210	1	4	NA	NA	Yes	-1.1 dB	NA	NN
	SX112	1	8	NA	Yes	-1.1 dB	No	NN	Yes
	SX212	1	4	NA	NA	-1.1 dB	No	NA	Yes
	SX115	1	8	NA	-1.1 dB	No	No	Yes	-1.1 dB
	SXC(F)115	2	8	NA	-2.0 dB	No	No	Yes	-2.0 dB
	SX215	1	4	NA	NA	No	No	NA	-1.1 dB
	SX118+	1	8	NA	No	No	No	-0.8 dB	No
	SX118	1	8	NA	-2.0 dB	No	No	Yes	-2.0 dB
	SXC(F)118	2	8	NA	-2.0 dB	No	No	Yes	-2.0 dB
	SX218+	1	4	NA	NA	No	No	NA	No
	SX218	2	8	NA	-2.0 dB	No	No	Yes	-2.0 dB
	SX218-MAR	1	4	NA	NA	No	No	NA	-2.0 dB
	SXH(F)218	1	4	NA	NA	No	No	NA	No
TH series	THS	2	8	NA	-1.1 dB	No	No	Yes	-1.1 dB
	THH, THV	2	8	NA	-0.8 dB	No	No	Yes	-0.8 dB
TORUS	T8	1	8	NA	Yes	Yes	-1.1 dB	NN	NN
	T12	1	8	NA	Yes	-1.1 dB	No	NN	Yes
Wavefront Precision	WPM	1	16	Yes	Yes	-2.8 dB	NA	NN	Yes
	WPS	1	6	NA	NA	Yes	No	NA	NN
	WPC	2	8	NA	Yes	No	NA	NN	No
	WPL	2	8	NA	No	No	NA	No	No
XE monitors	XE300	1 or 2	6	NA	NA	Yes	-0.5 dB	NN	NN
	XE500	2	4	NA	NA	Yes	-2.5 dB	NA	NN

Amplifier compatibility legend

Yes	The amplifier channel can deliver the required power to achieve the full pink noise rated output of the loudspeaker, providing a reasonable amount of headroom for dynamic music content.
-1.0 dB	The amplifier channel provides sufficient power to meet the loudspeaker's RMS requirements (based on a 20 Hz – 20 kHz sine wave). However, it is unable to deliver the 6 dB peaks found in the AES pink noise test signal, which more accurately reflects the demands of dynamic music content. The table shows the shortfall in dynamic headroom, expressed in decibels.
No	The amplifier channel does not meet the loudspeaker's pink noise or RMS power requirements and is therefore not recommended. However, it may still be suitable if the application does not demand the full rated output of the loudspeaker.
NN	Not needed: channel bridging is unnecessary, as a single amplifier channel provides sufficient power to drive the speaker.
NA	Not applicable: this impedance does not apply to this speaker.

Note that it is far more likely that an underpowered amplifier will damage a loudspeaker than one with excess power. Modern limiters in speaker presets can safely manage the amplifier's output. However, driving a system into distortion due to an insufficiently powered amplifier can cause heat buildup and lead to voice coil burnout, which is the most common form of loudspeaker damage.

If you need assistance with system design, please contact [Technical Support](#).

Martin Audio Limited

Century Point

Halifax Road

Cressex Business Park

High Wycombe

Buckinghamshire

HP12 3SL

England

FOR SALES ENQUIRIES

UK

+44 1494 535 312

info@martin-audio.com

NORTH AMERICA

+1 323 381 5310

www.martin-audio.com

Martin Audio, the Martin Audio logo and Hybrid are registered trademarks of Martin Audio Ltd. in the United Kingdom, United States and other countries; all other Martin Audio trademarks are the property of Martin Audio Ltd.

