

# MARTIN AUDIO XE SERIES

## XE300/XE500 USER GUIDE





# CONTENTS

- APPROVALS..... 4
- UNPACKING THE UNIT ..... 4
- INTRODUCTION ..... 5
- OVERVIEW ..... 6
  - Safety Note ..... 6
  - Coaxial Differential Dispersion® Technology ..... 6
  - XE Series - models ..... 7
    - XE300 ..... 8
    - XE500 ..... 8
- CONNECTIONS ..... 9
  - XE300 only – crossover modes ..... 10
  - Cable lengths ..... 10
- IK42 AMPLIFIER ..... 11
  - Maximum drive capability ..... 11
- IK42 OPERATIONAL GUIDE ..... 11
  - Introduction ..... 11
  - Key Features ..... 11
  - Drive Modules ..... 12
  - Overlays ..... 12
    - LIR Linear Phase Crossover Filtering ..... 13
    - FIR Linear Phase Equalisation..... 13
  - User guide ..... 13
  - Installation Instructions..... 14
    - Mechanical Installation ..... 14
    - AC Power Connection ..... 15
    - Audio Connections ..... 15
    - Load Matching..... 16
  - Panel Layouts..... 17
    - Front Panel ..... 17
    - Rear Panel ..... 19



Quick start .....20  
    Loading XE500 (or XE300 Bi-amp) Presets .....20  
    Loading XE300 Passive Presets.....22  
Vu-Net.....24  
    Processing Block Diagram.....25  
    Input Menu Map .....26  
    Output Menu Map.....27  
    Utility Menu Map.....28  
MOUNTING OPTIONS.....29  
    Flying LE Series monitors .....30  
ACCESSORIES .....30  
XE SERIES MONITOR SPECIFICATIONS.....31  
IK42 AMPLIFIER TECHNICAL SPECIFICATIONS.....32  
    XE Series Monitors - Technical Drawings .....35  
WARRANTY.....36  
COPYRIGHT AND TRADEMARKS .....36

## APPROVALS



This equipment conforms to the requirements of the EMC Directive 89/336/EEC, amended by 92/31/EEC and 93/68/EEC and the requirements of the Low Voltage Directive 72/23/EEC, as amended by 93/68/EEC.

EMC Emission: EN55103-1:2009

EMC Immunity: EN55103-2:2009

Electrical Safety: IEC60065:2002 + A2:2010

## UNPACKING THE UNIT

Thank you for purchasing a Martin Audio XE Series stage monitor. Every Martin Audio loudspeaker is built to the highest standard and thoroughly inspected before it leaves the factory. After unpacking the monitor, examine it carefully for any signs of transit damage and inform your dealer if any is found. It is suggested that you keep the original packaging so that the system can be repacked at a future date if necessary. Please note that neither Martin Audio nor its distributors can accept any responsibility for damage to any returned product which arises through the use of non-approved packaging.



Please think of our environment.

When the product has reached the end of its useful life, please dispose of it responsibly through a recycling centre.

## INTRODUCTION

Thank you for purchasing this Martin Audio XE Series stage monitor system. Designed in consultation with leading monitor engineers, the XE Series uses engineering innovation to set a new standard in on-stage monitor sound and lets performers hear themselves and their fellow musicians clearly, dynamically and with presence.

Martin Audio XE Series on-stage monitors deliver high performance in a compact, low-profile package. Our exclusive Coaxial Differential Dispersion® Technology is employed to overcome the common constraints of wedge monitor speaker designs, be they conventional designs with separate LF and HF drivers or other coaxial solutions. Coaxial Differential Dispersion® technology combines the 'point-source' advantage of coaxial designs with the consistency of coverage of Differential Dispersion. Horizontal coverage reduces from 60° directly over the monitor to 30° fatter back, giving a near-rectangular sound coverage area at head height which maintains both sound level and balance throughout the coverage area, allowing the performer natural freedom of movement. XE Series drivers incorporate a patent-pending static third waveguide that increases the size of the horn mouth: this further controls the response pattern and minimises spill outside the coverage area. Front reflex ports couple the monitors to the floor, increasing LF output.

The wedge-style cabinets are neat and unobtrusive, with a low profile to improve audience and camera sight lines. The enclosures are constructed from strong multi-laminate birch ply, with integral carrying handles and a black textured finish to minimise reflections from stage lighting. The grilles are black perforated steel with an acoustically transparent black scrim cloth backing. Both end faces have moulded rubber feet to protect the monitor during set-up and break-down and the rear of the cabinet base has two folding riser feet to increase the monitoring angle when circumstances require it. Four NL4 connectors are fitted for ease of on-stage cabling and to facilitate daisy-chaining.

XE Series monitors use two-way, full-range coaxial drivers, incorporating Martin Audio's exclusive Differential Dispersion® horn technology. There are two models: the XE300, based on a 12" driver rated at 300 W\*, and the XE500, based on a 15" driver rated at 400 W\*. The XE300 has an internal passive crossover (at 1.1 kHz) optimised for the driver, but may be bi-amped if wished. The larger XE500 is designed for bi-amp operation only.

The XE Series system includes the iK42 four-channel power amplifier. This model has been developed specifically for use with the XE Series cabinets and the combination will give monitor engineers the confidence that performers' on-stage monitoring experience will be the same night after night, from one venue to another. The iK42 has huge power reserves, an advanced onboard DSP section, is fully compatible with Martin Audio's Vu-Net control application and is provided with audio inputs for analogue, AES3 and Dante™ network signals.

This User Guide provides a detailed explanation of the various features of XE Series monitors. The iK42 power amplifier has its own User Guide, which contains full details of amplifier and DSP configuration. Please take the time to read through both Guides even if you are experienced with other Martin Audio products.

Thank you again for placing your confidence in Martin Audio products.

\* All power ratings are AES.

## OVERVIEW

### SAFETY NOTE

It is important that loudspeaker systems are used in a safe manner. Please take some time to review the following points concerning safe use of XE Series loudspeakers:

- Professional loudspeakers are capable of producing extremely high sound levels and should be used with care.
- Hearing loss is cumulative, and can result if people are exposed to levels above 90 dB SPL for a long period.
- Never stand close to loudspeakers driven at high level.

### COAXIAL DIFFERENTIAL DISPERSION® TECHNOLOGY

XE Series monitors feature Martin Audio's unique, patented Coaxial Differential Dispersion® technology. The design augments the 'point-source' benefits of coaxial drivers with the consistency of coverage which Coaxial Differential Dispersion® technology can deliver.

Non-coaxial systems can suffer from uneven frequency response in the crossover region because of interference between the LF and HF sections; this causes off-axis variations, undesirable in a stage monitoring environment. In contrast, coaxial systems aim to sum LF and HF contributions at all positions off-axis, and over a range of distances from the loudspeaker.

A disadvantage of conventional coaxial devices can be HF beaming, where the HF dispersion reduces at higher frequencies. This is primarily because the HF energy emerges through a narrow tube in the pole-piece of the magnet system. Coaxial Differential Dispersion® drivers overcome this by the use of a static waveguide that merges seamlessly with the unique cone shape — maintaining the dispersion pattern even at very high frequencies.

A Coaxial Differential Dispersion® horn has a trapezoidal dispersion pattern in both vertical and horizontal planes which covers the target area more evenly than a system with a conventional, fixed-dispersion type horn. A conventional horn tends to produce an imperfect coverage pattern which misses out some areas — particularly side areas close to the loudspeaker.

In contrast, a Coaxial Differential Dispersion® system as implemented in the XE Series produces a near rectangular coverage pattern at head height. The consistency of frequency response and SPL thus achieved throughout the target area is exceptional, and furthermore the area itself is more extensive than with conventional monitors, allowing the performer a great deal more flexibility of movement while remaining in the sound field.

**XE SERIES - MODELS**

There are two models in the XE range: one based on a 12" driver, the other on a 15" driver.



XE300



XE500

The basic characteristics of the two models are summarised below (full specifications at "XE Series Monitor Specifications" on page 31).

Model	Driver (dia.)		LF -3 dB point	Power rating*		Impedance	
	LF	HF		LF	HF	LF	HF
XE300	12" (300 mm)	1.4" (35 mm)	67 Hz	350 W	80 W	6 ohms	8 ohms
XE500	15" (380 mm)		62 Hz	550 W		4 ohms	

\* AES power ratings

Both models are fitted with four fully-paralleled NL4 type connectors: two are fitted at the front (facing the performer) and one at each end. Recessed carrying handles are fitted in both ends for easy handling: the XE500 has heavier bar type handles to take account of the extra weight. The normal operating angle (to the horizontal) is 27.5° (XE300) or 30° (XE500); the angle increases to 40° in both cases when the rear feet are extended. Both models have two M8 inserts in each cabinet end face; eyebolts to fit these are available as a standard accessory to permit flying where desired.

**XE300:**

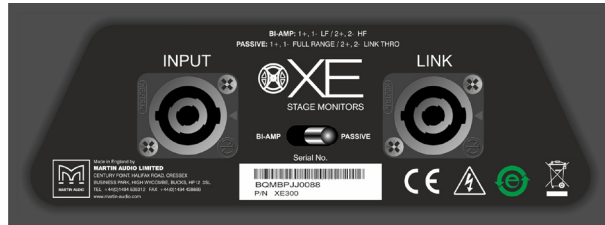

The XE300 may either be bi-amped or driven by a single full-range amplifier. For full-range use, it uses an internal crossover at a frequency of 1.1 kHz. The two modes of operation are selected by a switch on the front connector panel.

**XE500:**

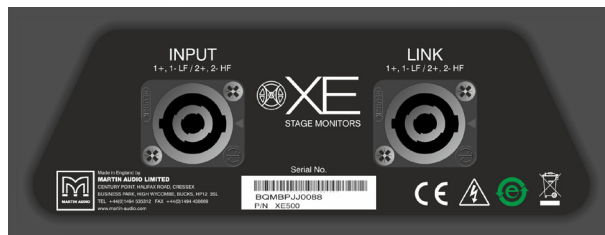

Model XE500 is designed for bi-amp use only.

## CONNECTIONS

XE Series monitors are fitted with low-profile, NL4-type four-pin push-lock connectors, rated at 30 A. All the connectors are wired in parallel: use whichever suit the stage cabling layout. The provision of multiple connectors permits simple interconnection between monitors on the same circuit; they can be used to “daisy-chain” the amplifier output to further speakers. However, note that all four pins on each connector - including any that are unused by the speaker itself - are wired in parallel (pin-to-pin) to all the other connectors on the cabinet.

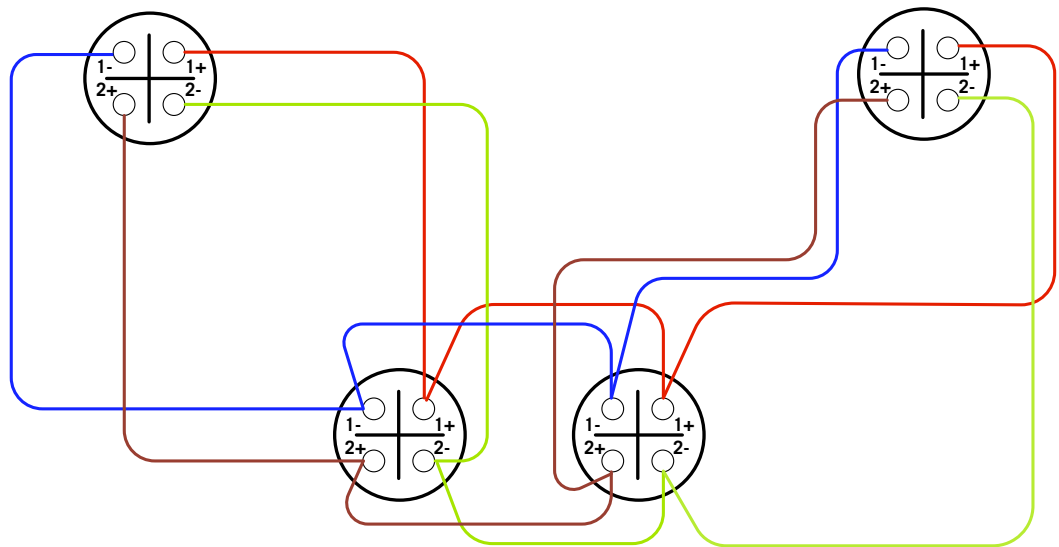

**Important:** Each iK42 amplifier channel can drive a maximum of two XE Series monitors in parallel. Do not attempt to connect more than two monitors to any one amplifier channel as the combined load impedance will be lower than the minimum impedance the amplifier is designed to drive. This will result in unsatisfactory performance and may cause damage to the amplifier.

Wire the mating connectors according to the following pinout table:

Pin	XE300		XE500
	Passive x-over	Bi-amped	Bi-amped only
1+	Input '+'	LF input '+'	LF input '+'
1-	Input '-'	LF input '-'	LF input '-'
2+	(no connection)	HF input '+'	HF input '+'
2-	(no connection)	HF input '-'	HF input '-'

The speaker output connectors on the iK42 amplifier are also NL4 type (Neutrik Speakon™). The connectors for amplifier Channels 1 and 3 also carry the outputs of Channels 1 and 4, so that when the amplifier channels are configured in pairs for bi-amp operation, standard four-core speaker cables terminated in NL4s may be used throughout the system without a problem.

**XE300 ONLY – CROSSOVER MODES**

The XE300 may be switched between passive (full-range) mode and bi-amped mode with the switch located on the recessed front panel between the two connectors.

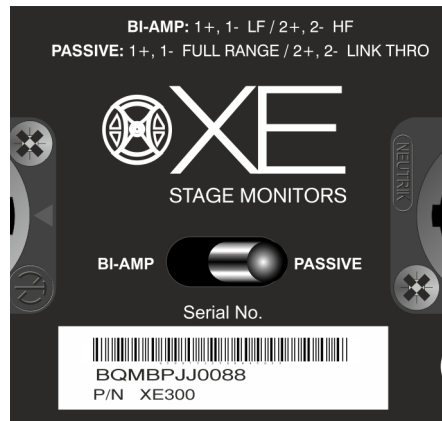

- Set the switch to **PASSIVE** if driving the XE300 with a full-frequency range amplifier channel, and wire only the **1+** and **1-** pins of the NL4 connectors.
- Set the switch to **BI-AMP** if using an external electronic crossover or system controller in conjunction with separate amplifiers (or amplifier channels) for LF and HF. Wire the LF amplifier channel to pins **1+** and **1-**, and the HF amplifier channel to pins **2+** and **2-**.

**CABLE LENGTHS**

When connecting any loudspeaker system to an amplifier, it is recommended that the return resistance of the cable used is less than one tenth of the nominal impedance of the loudspeaker or loudspeakers in parallel. The table below gives an indication of the maximum permissible cable runs for various conductor cross-sectional areas.

Conductor CSA	Maximum Cable Run	
	4 ohms	8 ohms
1.0 mm <sup>2</sup>	11 m	22 m
1.5 mm <sup>2</sup>	17 m	34 m
2.0 mm <sup>2</sup>	22 m	44 m
2.5 mm <sup>2</sup>	29 m	58 m
4.0 mm <sup>2</sup>	44 m	88 m
6.0 mm <sup>2</sup>	66 m	132 m

## IK42 AMPLIFIER

### Maximum drive capability

The iK42 is a four-channel power amplifier, with the following maximum drive capacities:

- When used with XE300s in **PASSIVE** mode, each amplifier channel can drive a maximum of two monitors, meaning a total of eight monitors may be connected in four chains. Each chain may, of course, be fed with a different mix.
- When used with XE500s, or XE300s in **BI-AMP** mode, each amplifier channel can drive a maximum of two monitors, with separate channels being used for the HF and LF inputs. This means a total of four monitors may be connected in two chains. Each chain may, of course, be fed with a different mix.

## IK42 OPERATIONAL GUIDE

### INTRODUCTION

The Martin Audio iK42 Series Advanced System Amplifier represents current state-of-the-art technology in several areas. This product is the result of several years of research, from which many advances in switched mode power technologies and ever finer detail in signal processing have stemmed. Taking advantage of the latest advances in analogue to digital conversion technologies, the unit achieves performance levels among the very best that engineering permits.

### KEY FEATURES

- Four/Eight channels of sonically pure Class D amplification
- Very high power density - packs four channels and 20 kW into just 2U of rack space
- Packed with robust protection and monitoring systems to keep the show going
- External Breaker Protection (EBP) limits the current draw to prevent breakers opening
- Martin Audio minimal signal path design
- Class leading sonic performance achieved by the use of state of the art Amplifier technologies and highly advanced DSP algorithms using Linea Micro Detail (LMD)
- 96 kHz sampling frequency provides for a nominally flat response beyond 40 kHz
- Rotary encoders, illuminated buttons and graphical display provide a rapid, intuitive and user-friendly control interface
- High speed Ethernet communications supporting DHCP, static-IP and auto-IP, and direct connection to a computer without the need for a router or a switch
- Powerful Drive Module concept, abstraction from device-centric to speaker-based control
- Innovative Component Presets to allow individual outputs to be used for selected drivers of a loudspeaker system
- Twelve layers of Parameter Overlays for trouble-free Grouping
- Unique VX limiter providing dynamic control for passive 2-way enclosures
- Unique LIR linear phase crossover shapes giving FIR-like performance without the drawbacks

- Linear phase HF system EQ profiling which provides perfect integration between enclosures
- Innovative excursion control limiter with sliding High Pass Filter; limits only the damaging low frequencies
- Transducer thermal modelling provides regulation limiters, addressing long term overload
- Overshoot limiter governs amplitude of transient signals retaining average power whilst constraining peak energy
- Dante audio networking with automatic fall-over to Analogue or AES3
- AES3 inputs

## DRIVE MODULES

The iK42/iK81 Series processor has a new way of ordering and grouping channels in order to give a more speaker-based approach to controlling, designing and recalling speaker configurations; these are called Drive Modules. A Drive Module is the Processing provided by one Input DSP Block, and a number of Output DSP Blocks, which are associated with one-another by means of routing. For example, if Input DSP Block B is routed to Outputs 3 and 4, then this is a 2-way Drive Module with Input DSP Block B forming the 'Master' control, and Output DSP Blocks 3 and 4 providing the driver-related control. Overall, this forms the processing typically for one loudspeaker sub-system. The Vu-Net Drive Module control panel for this sub-system may then be used for control and monitoring of the associated speaker.

Drive Modules may be included in Module Groups, which use the Parameter Overlay feature in the Device to achieve trouble-free Grouping in the Vu-Net application.

The Presets in the Device are Drive-Module centric, and are used to configure individual Drive Modules rather than the whole device.

Importantly, Drive Modules move the focus away from the processing device, and onto the loudspeaker systems.

A Drive Module Preset may be broken apart into Components, allowing any output to be used for any component within a Drive Module Preset (i.e., any driver in a loudspeaker subsystem).

## OVERLAYS

When the Device is used in Modules view in Vu-Net, it allows the modules to be grouped into Overlay Groups. These groups allow various Input (master) parameters to be adjusted in all modules in that group, whilst maintaining independent parameter values across each group. This is achieved in the device by combining the parameters for all the layers for a given section (Gain Delay, EQ etc.). When an Overlay parameter is active, the Overlay indicator will become illuminated. The combined Gain or Delay etc. associated with a given section is shown on the module panel in Vu-Net, within square brackets "[ ]" under the Delay and Gain for each input channel. The combined EQ curve is shown in an olive colour. The Input Mute button in Vu-Net will flash if an overlay mute is active. On the device, the presence of an active overlay is generally indicated by square brackets "[ ]" after the parameter value on the display. An input overlay mute is indicated on the mute/clip indicator for that channel flashing. Note that overlay parameters cannot be adjusted on the Device itself; these can only be controlled by the Vu-Net application. However, overlay parameters may be removed on the device – see Overlay Flush. Note that overlays are not stored in presets or snapshots or carried in settings files.

### **LIR Linear Phase Crossover Filtering**

The Device also includes a new type of crossover filtering “Linear Impulse Response” (LIR) crossover filtering, which results in a Linear Phase crossover that has a constant delay regardless of frequency (unlike other types of crossover which delay different frequencies to a different extent, thus smearing the arrival time). The LIR crossover can thus be described as having a flat Group Delay response, and thus entirely free of Group Delay Distortion.

The shape of the LIR crossover filter is quite similar to a 4th order or 24 dB/Oct Linkwitz-Riley filter, and maintains zero phase difference between the adjacent bands across the crossover region to keep the polar response rock steady.

### **FIR Linear Phase Equalisation**

The Input High-Shelf Equalisers use Finite Impulse Response (FIR) filtering to produce Linear Phase equalisation; that is all frequencies are delayed by the same amount, perfectly preserving the transient response. This can also be important in applications where different amounts of EQ are applied to different parts of a speaker cluster, such as to add ‘Throw’ EQ boost so that parts of cluster which are throwing further can have HF absorption correction added. If this EQ is not linear phase, then the zones where the speakers combine may suffer frequency response anomalies.

## **USER GUIDE**

A dedicated User Guide for the iKON amplifiers is available for download from the Martin Audio website.

## INSTALLATION INSTRUCTIONS

### Mechanical Installation

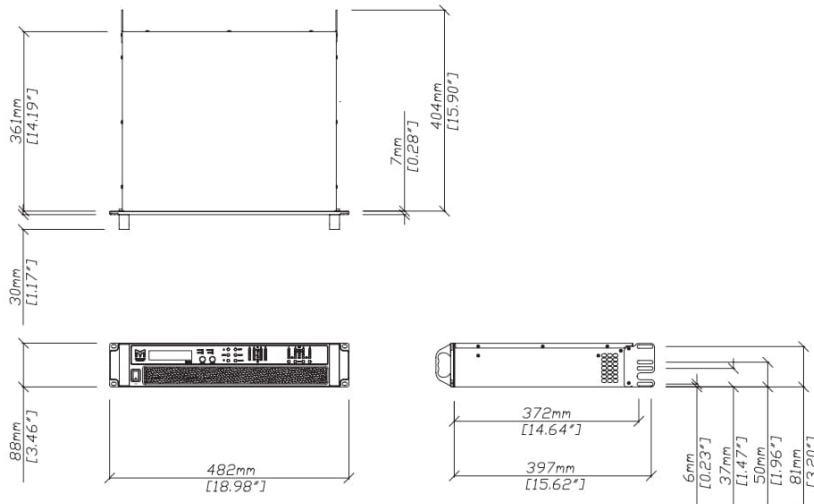

The iK42/iK81 Series Amplifier system is designed to be mounted in a standard 19" rack enclosure.

Where the amplifier is used in a fixed installation, as long as the bottom unit is supported and there are no gaps between units, it is acceptable to use only the front panel 19" rack holes when fitting it in a standard rack enclosure. If the amplifier is mounted in a mobile rack it is important that the rear is supported with a rear rack mounting kit (part number IKRACK). Damage caused by insufficient support is not covered by the warranty.

To prevent damage to the front panel it is recommended that plastic cups or washers are fitted underneath the rack mounting bolt heads.

It is possible to mount multiple iK42/iK81 Series amplifiers without ventilation gaps between them but it is essential that an unobstructed flow of clean air is available from the front of the unit to the rear. It is important that neither the air intakes on the front of the unit or the exhaust vents at the rear are covered. Steps must be taken to ensure that hot air does not continually circulate through the amplifiers from the back of the rack to the front.

The amplifier should never be exposed to rain or moisture during operation or storage. If the unit does come into contact with moisture, remove the AC power cable immediately and leave it in a dry and warm location to dry out.

Note that when any equipment is taken from a cold location into a hot humid one, condensation may occur inside the device. Always allow time for the equipment to attain the same temperature as its surrounding environment before connecting the AC power cable.

**Important:** It is the responsibility of the user to ensure that dirt, liquids and vapour from theatrical smoke and fog machines is not ingested by the amplifier. Damage so caused is not covered by the manufacturer's warranty.

## AC Power Connection

The amplifier utilises a 32 A Neutrik PowerCon™ type locking AC power connector. Use only an AC power cable with a correctly terminated PowerCon™ type connector to make the connection to the mains power supply.

The amplifiers are designed to operate on 50/60 Hz AC power. The power supply sections automatically configure themselves for either 115 V or 230 V nominal voltage at turn on. The amplifiers will operate over an extended range of supply voltages (please refer to the technical specifications).

Note that whilst the amplifier will operate correctly at voltages indicated, the specified output power will only be achieved when operating with the stated nominal voltages.

## Audio Connections

### Input Connections

For each input channel there is a female XLR connector for analogue inputs. There is also one female XLR for one stream (two channels) of AES3 digital audio. Note that only two channels of AES3 digital audio are available. The Dante option permits more channels of Digital Audio inputs.

- The HOT, + or 'in phase' connection should be made to pin 2 of the XLR connector.
- The COLD, - or 'out of phase' connection should be made to pin 3 of the XLR connector.
- Pin 1 of the XLR connectors is internally connected to the chassis. The shield of the input cable should always be connected Pin 1 of the XLR to ensure that EMC performance and regulations are met.

Input XLR balanced connection

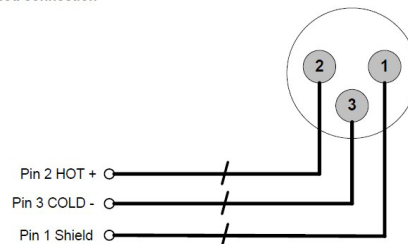

### Using unbalanced connections

Please note that the use of unbalanced connections is not recommended, however when connecting the amplifier to an unbalanced audio source, the signal conductor should be connected to XLR pin 2. The 'Cold' conductor or cable screen should be connected to XLR pin 1 with a short connection made between pin 1 and pin 3.

Input XLR unbalanced connection

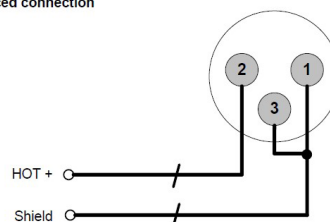

### Amplifier Output Connections

The iK42 amplifier is fitted with one Speakon™ connector per amplifier channel. The appropriate conductor terminations are shown below and on the rear panel of the unit.

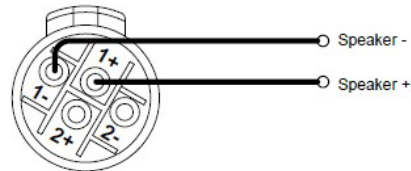

Additionally, the channel 2 output is duplicated on the Speakon™ connector for amplifier channel 1 for Bi-Amp wiring. Similarly, the channel 4 output is duplicated on the Speakon™ connector for amplifier channel 3. This can be useful for making a connection to two loudspeakers with one 4-core cable (i.e., Bi-Amp).

On the iK81 model, all outputs are Bi-Amp; each Speakon™ connector carries two amplifier outputs – Channels 1 & 2, Channels 3 & 4, Channels 5 & 6 and Channels 7 & 8.

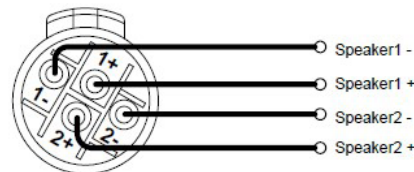

In addition, the channel 1 or channel 3 connector (all the Speakon™ connectors on the iK81 model) can also be used if the pair of amplifier channels is being operated in bridged mode.

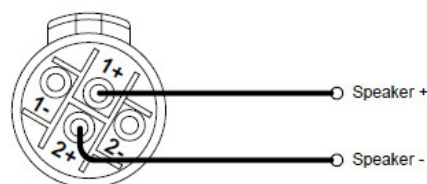

More than one speaker can be connected to each channel provided the total impedance per channel is not less than **2 ohms**. In bridged mode the minimum total impedance should not be less than **4 ohms**.

### Load Matching

Each output of the device can be optimised to drive either a low impedance load (e.g., 2, 4 or 8 ohms), or a Constant Voltage (C.V.) using the Load parameter in the Output menu. There are several C.V. settings (25 V, 70 V and 100 V Line) which determine the maximum RMS voltage that the amplifier will produce. Select the one which is appropriate for the installation. A number of low impedance settings (depending on the model) are also available. Although it is not critical that this setting matches the impedance of the connected load, this will maximise the power that is available for the load.

## PANEL LAYOUTS

(The iK42 is illustrated. The iK81 is similar, but with double the quantity of output indicators and mute buttons).

### Front Panel

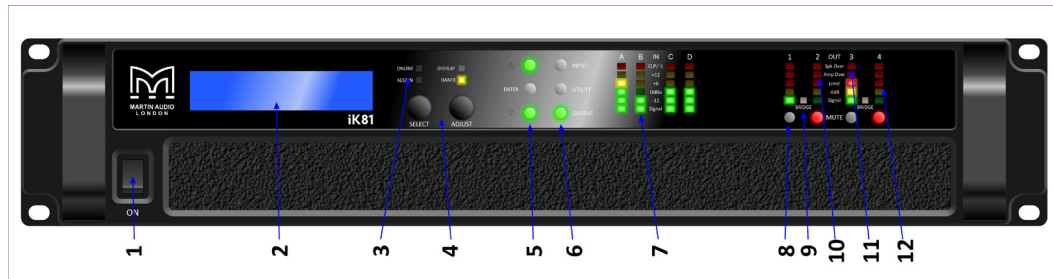

1. Power Switch – Applies mains power to the device. If the device has entered Sleep mode, it may be woken up again either from the Vu-Net application, or by switching this switch off, then on again.
2. Graphical Display – This will show the Home screen; a useful overview of channel allocation. On most pages the currently selected channel and parameter information is displayed on the upper part of the screen and the parameter value on the lower part of the screen. The screen contrast can be changed by pressing the **UTILITY** button to navigate to “Screen” and using the encoders to change the percentage; this can also optimise the viewing angle.
3. Status Indicators – The **OVERLAY** indicator shows when there are parameters active on a group layer, which the user cannot access through the front panel of the device (see Overlay Flush). The **DANTE** indicator shows that a Dante network feed is routed. The **ONLINE** indicator has three states: Off – the unit is offline and not connected to a computer or network. Flashing - the unit is searching for an IP address; if the unit does not find an IP address the unit will assign itself an IP address automatically and the indicator will stop flashing. On - the unit is online and connected with software. IP settings can be viewed or changed within the **UTILITY** pages. The **AES3 IN** indicator illuminates when one or more of the inputs is using an AES3 source.
4. Parameter Encoders – Two velocity sensitive parameter encoders are used to adjust parameters shown on the display. Up to three parameters at a time are displayed on the screen. The parameter name is shown above the parameter value in each of the three screen sections. Use **SELECT** to highlight the parameter, then **ADJUST** to change it.
5. Page Selection Buttons – When one of the buttons **INPUT**, **OUTPUT** or **UTILITY** is illuminated, the ▲ and down ▼ arrows will also illuminate, informing the user that these buttons may be used to scroll through the various pages of parameters that may be viewed and edited. The **ENTER** button is used to confirm an operation such as storing or recalling a preset or snapshot. It will illuminate when the user is being invited to press it. It will flash when warning the user that pressing this button will activate an important function.

6. **Menu Buttons** – There are three buttons to determine which section of the device to view or edit. The **OUTPUT** button displays pages of parameters associated with a particular output channel. The **INPUT** button displays pages of parameters associated with a particular input socket or input DSP channel. Pressing **INPUT** or **OUTPUT** buttons repeatedly will scroll through the inputs/outputs of the device. After the last channel, navigation returns to the Home screen. The **UTILITY** button displays pages of miscellaneous parameters not associated with any particular channel. Whilst in Edit mode, one of these three buttons will be illuminated. They are mutually exclusive - pressing one of the buttons will deselect any others that are active. Pressing Utility will escape back to the Home screen.
7. **Input Signal Indicators** – A set of five indicators show **Signal, -12, 0dBu, +6, +12** and **CLP/mute** for each of the DSP inputs **A, B, C** and **D**. The **Signal** indicators operate at approximately -40 dBu. The **CLP/mute** Indicators warn the user of input overload and operate at 1 dB before clip. This indicator also shows a muted input
8. **MUTE** buttons (4) – DSP output mute status is indicated and controlled by an illuminated button for each channel. These flash when the entire unit is muted from the AUX port or from Vu-Net Mute-All, or if this channel has been muted by the protection systems.
9. **BRIDGE** indicators (2) – these will illuminate when the channel pair is in Bridge mode. The controls for the left channel of the pair will determine the settings.
10. **Amp Over** indicators (4) – these indicate when the amplifier protection systems are reducing the gain to keep the parameters of the amplifier within specification, or when that the channel is clipping.
11. **Spk Over** indicators (4) – these indicate a signal 6 dB higher than the limiter threshold, or when the threshold of the excursion limiter has been exceeded, or when the thermal limiter is active. Please note that because of the long release time of the thermal limiter, this indicator may remain illuminated for several seconds after signal on that channel is reduced.
12. **Limit** indicators (4) – The output indicators shows the status of the limiter and output level. The level indicated is that before the limiter, referenced to the limiter threshold. The **SIG** indicator shows when a signal is present on the output. The second indicator **-6dB** shows that the signal has reached 6dB below the limiter threshold. The third **LIMIT** indicator indicates that the threshold of that output channel has been reached.

## Rear Panel

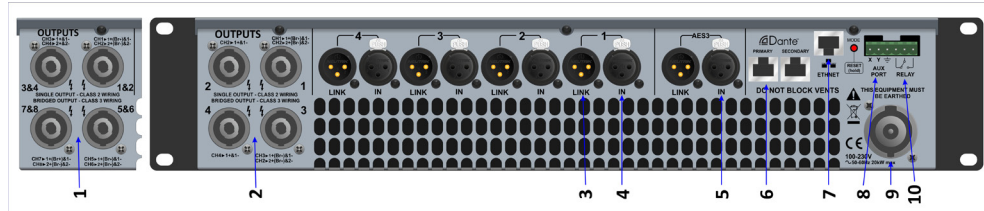

1. Loudspeaker Connectors (iK81). The amplifier Speakon™ outputs. Connect the first loudspeaker to the 1+ and 1- terminals and the second loudspeaker to the 2+ and 2- terminals. For Bridged mode, use terminals 1+ and 2+.
2. Loudspeaker Connectors (iK42). The amplifier Speakon™ outputs. Connect the loudspeaker to the 1+ and 1- terminals. CH1 also carries the (duplicated) loudspeaker output for channel 2 on terminals 2+ and 2-. Similarly, CH3 carries the loudspeaker output for channel 4 on terminals 2+ and 2-. For Bridged mode, use terminals 1+ and 2+ of either CH1 or CH3.
3. Analogue Audio Link Connectors – carries a duplicate (parallel) connection (to another amplifier for example).
4. Analogue Audio Input Connectors – all audio connections are fully balanced and wired: pin-1 to ground (as required by the AES48 standard), pin-2 hot & pin-3 cold.
5. AES3 Audio Input Connectors – for inputting Digital Audio signals. The Input is fully balanced and wired: pin 1: ground, pin 2: data+ and pin 3: data-. The LINK connector allows a buffered AES3 signal to be passed on to another device.
6. Dante Ports – connection ports for Dante™ with the Primary and Secondary port convention available.
7. Ethernet Communications Port – the amplifier may be controlled entirely using Martin audio's Vu-Net software and so can integrate easily with other products that are supported on the same platform such as the Multicellular range, CDD-Live, DD12 and PSX. Connection will normally be made via this Ethernet port connector. This port is also used for updating the firmware in the unit.
8. **AUX PORT** – the auxiliary port may be configured to recall snapshots or apply muting.
9. Power Inlet – the unit should be connected to a suitable mains electricity supply using an earthed 32 amp PowerCon connection power lead. The device has a switch mode power supply that is capable of operating with a nominal mains voltage of 100 V to 230 V, 50/60 Hz without re-configuration.  
**NOTE:** The device must be earthed to a suitable power earth; failure to do so may affect performance and/or operation and will invalidate warranty and could be potentially hazardous.
10. **RELAY** – this isolated relay output may be used to indicate abnormal conditions to external monitoring apparatus.

**QUICK START**

The iK81 and iK42 are not only powerful amplifiers but have extremely comprehensive processing ability allowing complex systems to be designed to suit any application for many applications however, all you need to do is recall the appropriate Preset, connect your speakers and source and away you go. This section shows you how to achieve the quickest, most straightforward set up using an iK42 to drive the XE range of monitors.

**Loading XE500 (or XE300 Bi-amp) Presets**

1. Connect the amplifier. The iK42 requires mains to be connected to its 32 Amp PowerCon inlet, and an input feed, either balanced analogue to the input XLRs, AES3 to the dedicated AES XLR, or Dante to the Dante RJ45 port. XE500 and any of the other monitors run in bi-amp mode can be connected directly to output Speakon 1 and 3 as these also have channels 2 and 4 respectively connected to pins 2+/- specifically for bi-amp operations. See “AC Power Connection” and “Audio Connections” on page 15 for more details.
2. Power up the amplifier, once it has completed its power-up cycle press **INPUT** and press the down arrow once to show the Preset recall for Channel A:

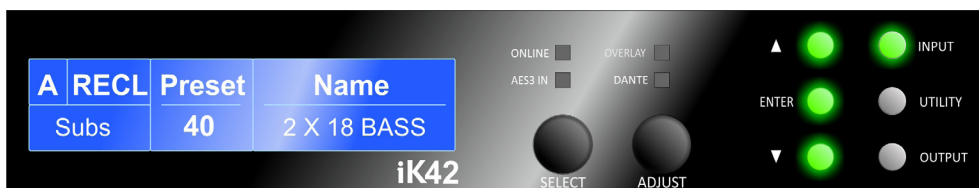

3. Use the **ADJUST** control to scroll round to the required XE500 Preset:



4. Press **ENTER** and you will see the following message:

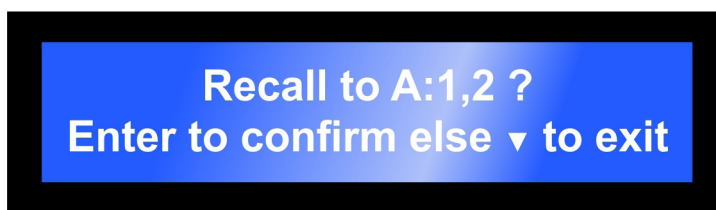

- The **ENTER** button will be flashing, press it and you will see the following:

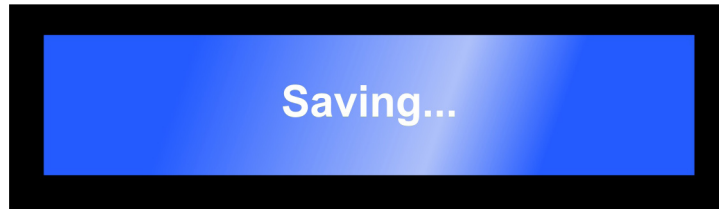

- Input A will now feed output 1 with the XE500 LF Parameters and output 3 with XE500 HF parameters. Press **INPUT** again:

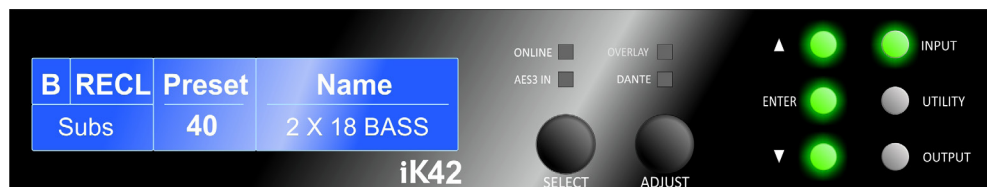

- You will notice that the screen is now showing the preset for input B. Again using the **ADJUST** control select the XE500 preset and press **ENTER**:

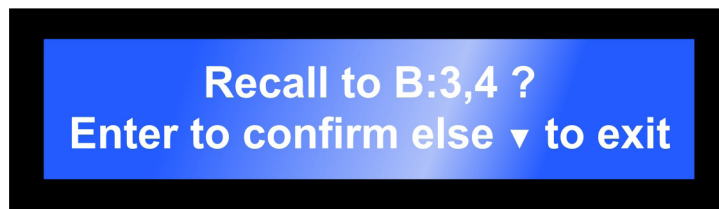

- Press **ENTER** and the preset loading is complete, press **UTILITY** to escape back to the default screen:

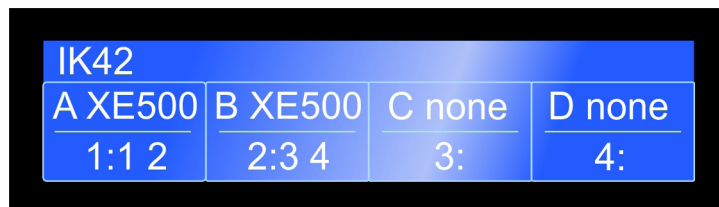

This shows that DSP A and B are both loaded with the XE500 preset. Input 1 is routed to output 1 & 2, input 2 is routed to outputs 3 & 4, output 3 and 4 are not used therefore not routed anywhere. The amplifier is ready for use.

**Loading XE300 Passive Presets**

Loading presets for passive monitors is exactly the same procedure other than it being necessary to define the preset for all four Inputs.

1. Connect the amplifier. The iK42 requires mains connected to its 32 Amp PowerCon inlet, an input feed, either balanced analogue to the input XLRs, AES3 to the dedicated AES XLR, or Dante to the Dante RJ45 port. XE300 in passive mode can be connected directly to output Speakons 1, 2, 3 and 4. See “AC Power Connection” and “Audio Connections” on page 15 for more details.
2. Power up the amplifier, once it has completed its power-up cycle press **INPUT** and press the down arrow once to show the Preset recall for Channel A:

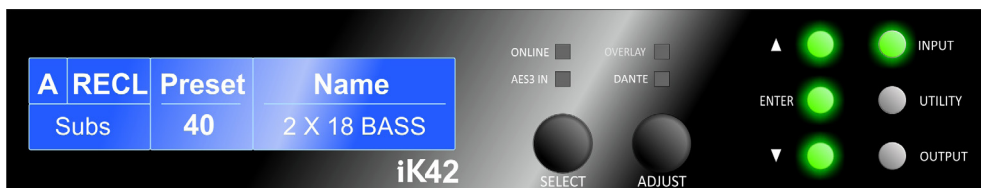

3. Use the **ADJUST** control to scroll round to the required XE300 Preset:



4. Press **ENTER** and you will see the following screen:

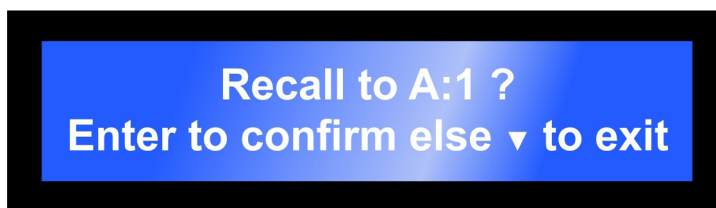

- Press **ENTER** again and you will see this screen:

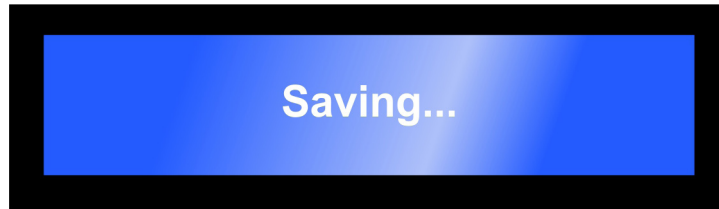

- Press **INPUT** again and you will see the Recall Preset Screen for input B:

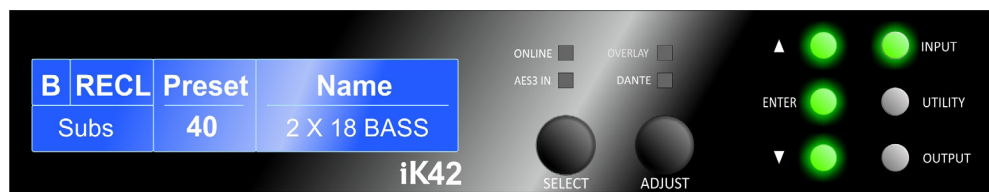

- Repeat the previous process, scroll the **ADJUST** knob to select the XE300 passive preset, press **ENTER** twice to confirm. When the preset is loaded press **INPUT** again to load the same preset into input C and repeat, finally press **INPUT** once more to enter the preset into input D. Press **UTILITY** to return to the home screen:

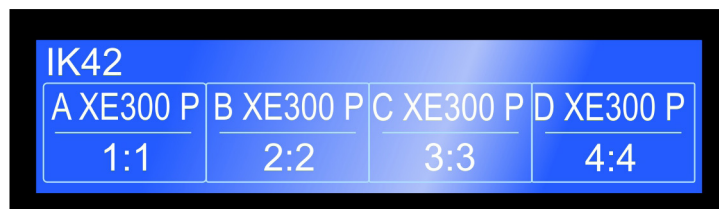

This shows that DSP A, B C and D are loaded with the XE300 Passive Preset, Input 1 is routed to Output 1, Input 2 to Output 2 and so on. The amplifier is ready to use.

**VU-NET**

iKon amplifiers feature an Ethernet connection to allow them to be networked together for control and monitoring of the system they are driving. This is achieved using a PC on the same Ethernet network running Martin Audio's Vu-Net software. Vu-Net allows comprehensive control of every amplifier function:

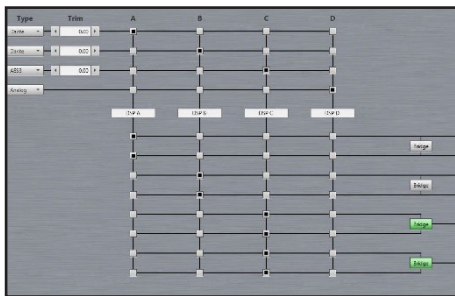
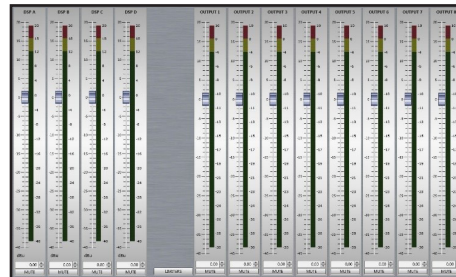
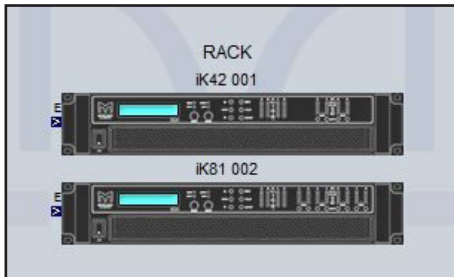

Key	Linking	Total Delay	A	B	C	D
001-01	Multi-Channel	0.000 ms				
001-02	Multi-Channel	0.000 ms				
001-03	Multi-Channel	0.000 ms				
001-04	Multi-Channel	0.000 ms				
001-05	Multi-Channel	0.000 ms				
001-06	Multi-Channel	0.000 ms				
001-07	Multi-Channel	0.000 ms				
001-08	Multi-Channel	0.000 ms				
001-09	Multi-Channel	0.000 ms				
001-10	Multi-Channel	0.000 ms				

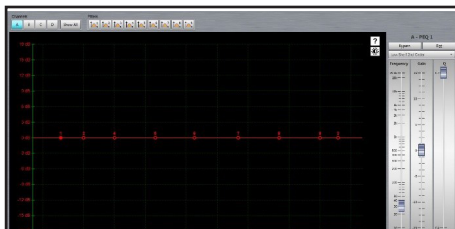

Vu-Net is available as a free download from the Martin Audio website. For full details of Vu-Net operation please also download the Vu-Net User Guide which shows Vu-Net operation for the iKon amplifiers and all Vu-Net enabled Martin Audio products.

Processing Block Diagram

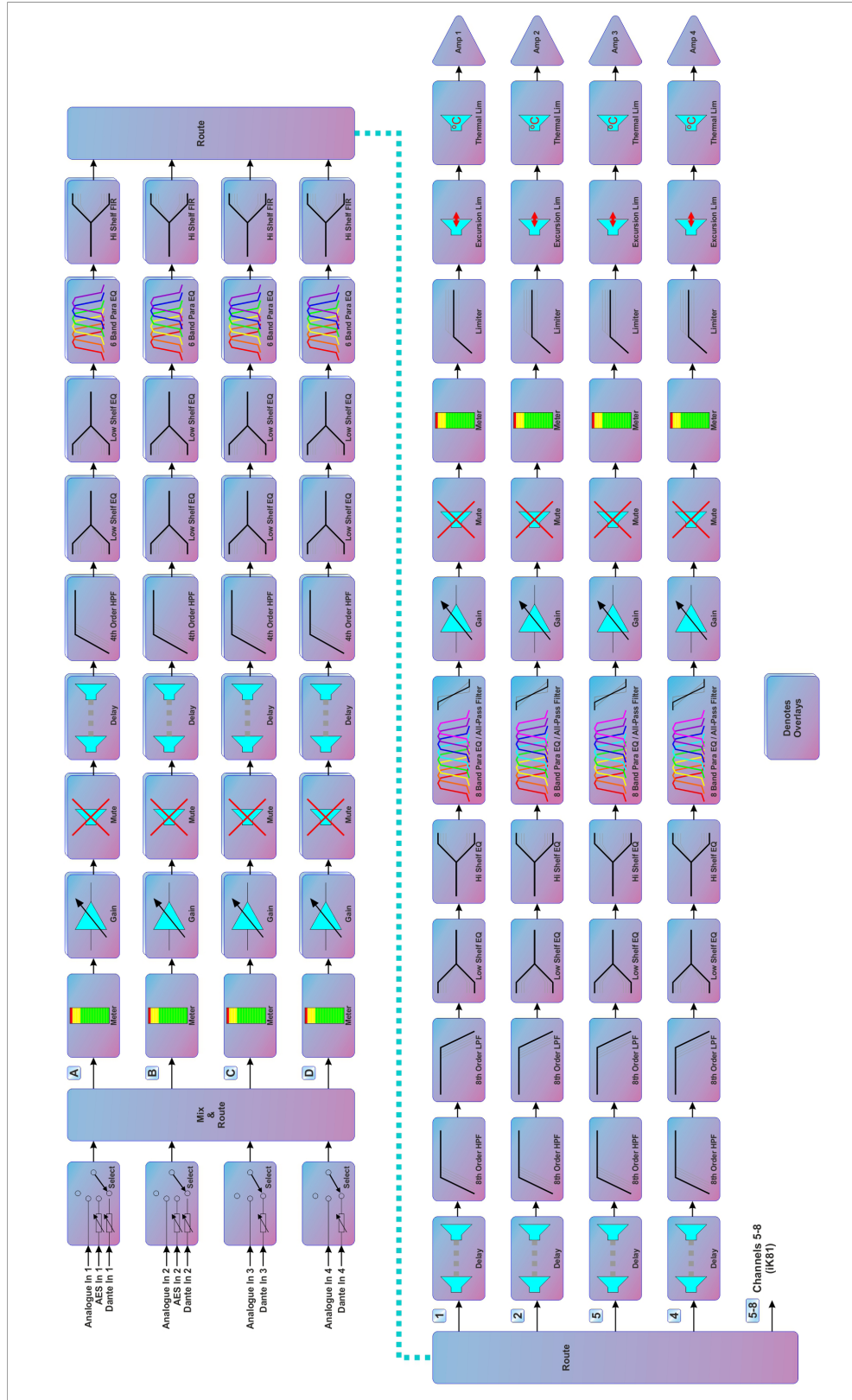

Input Menu Map

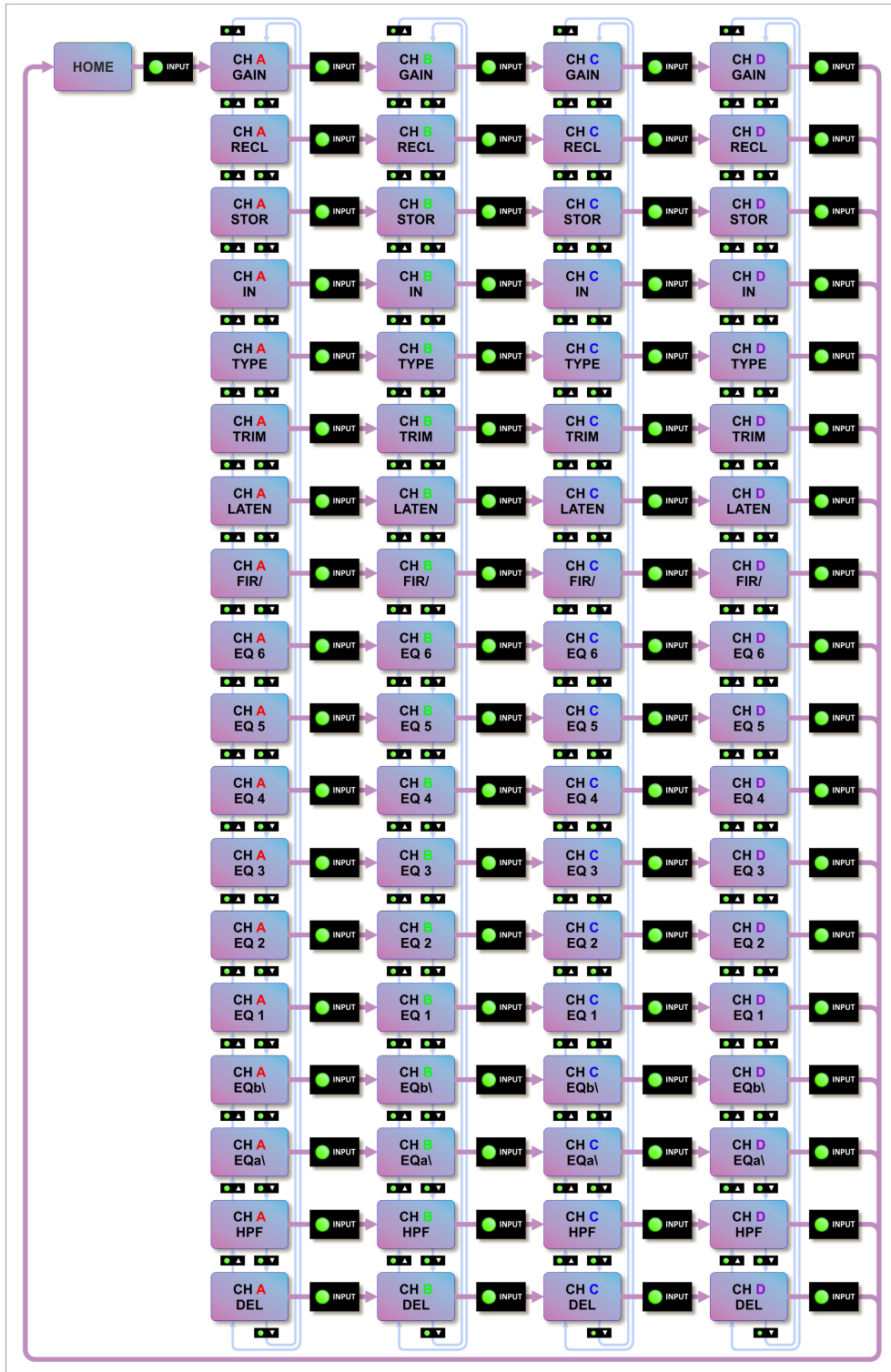

Output Menu Map

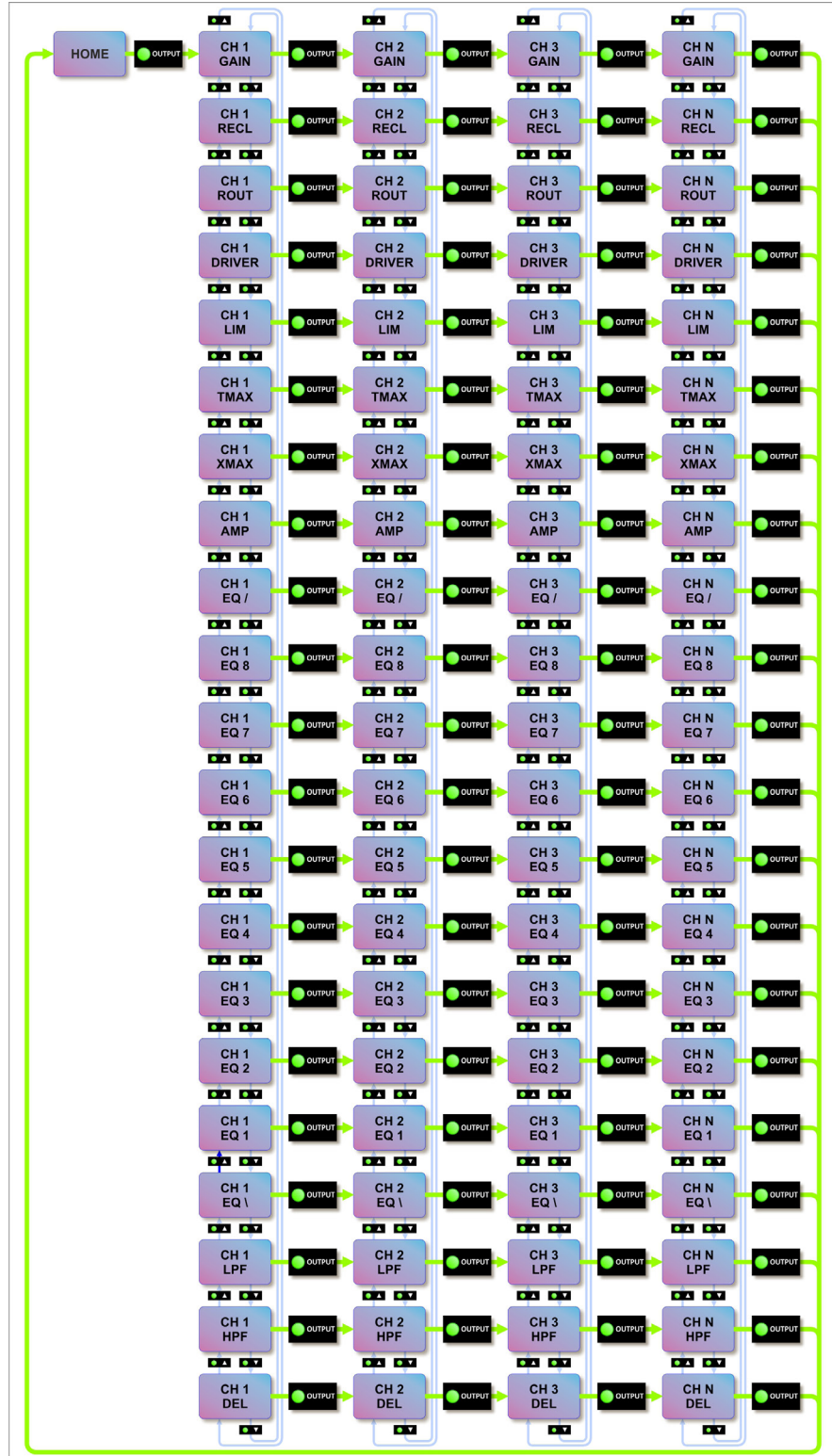



Utility Menu Map

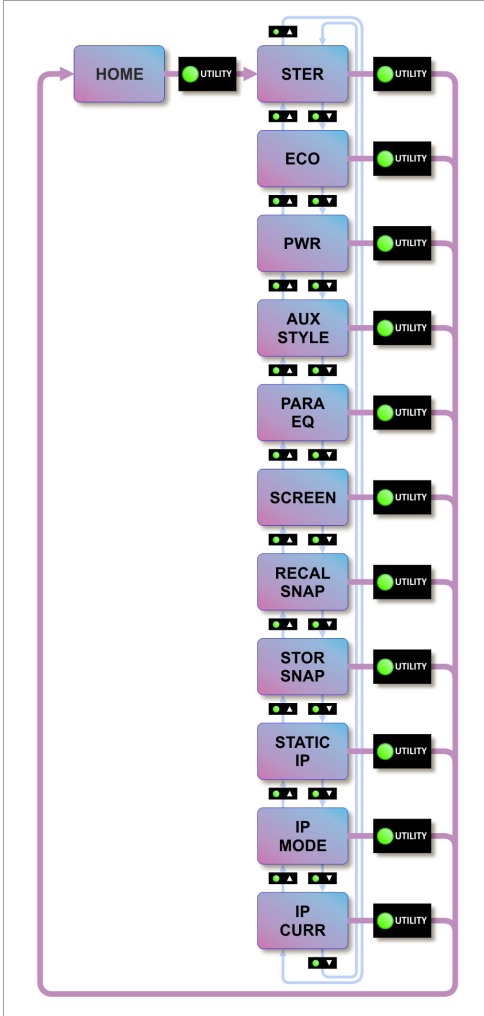

## MOUNTING OPTIONS

As wedge monitors, XE Series monitors will most often be used as free-standing cabinets in “landscape orientation” at floor level. The monitoring angle can be increased if necessary by extending the two built-in “risers” at the rear of the cabinet. These are normally stowed so that they are flush with the base of the cabinet, but can be simply hinged outwards to raise the rear of the cabinet.



The enclosures are fitted with moulded rubber feet on the base which protect the stage and help the units to retain their position.

The coverage at ear height of the XE500 when used in “landscape” orientation (i.e., normal wedge mode, risers not extended) is shown below:

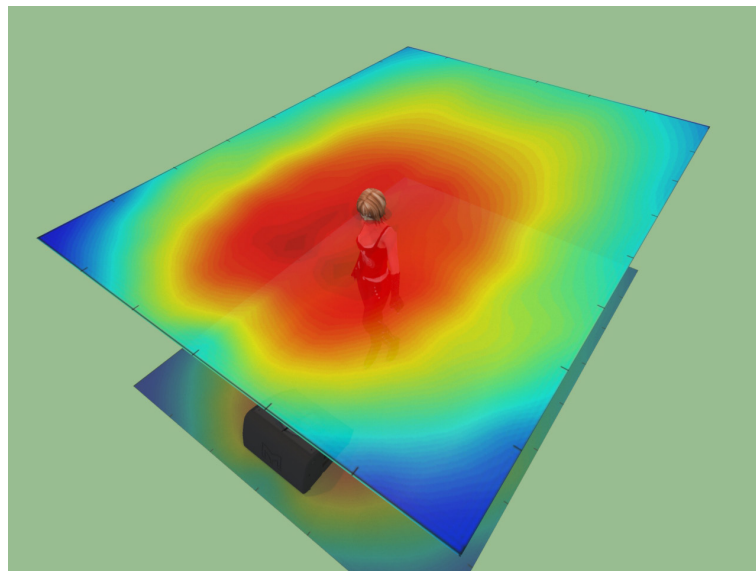

**FLYING XE SERIES MONITORS**

The XE300 and XE500 are also suitable for mounting at height: both models have two M8 inserts in each end of the enclosure into which eye bolts may be fitted, to allow them to flown from a truss using standard rigging techniques.

**Important:** To maintain the correct coverage characteristics, XE Series should only be flown upside-down.

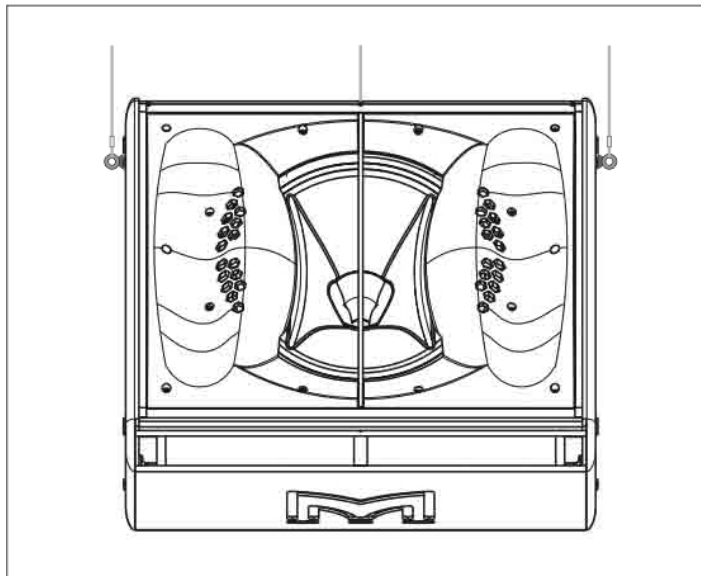

When flying any loudspeakers, always observe standard industry guidance regarding truss loading and safety considerations. The weights of XE Series enclosures are:

Model	Weight
XE300	19 kg (41.9 lbs)
XE500	29 kg (63.9 lbs)

**ACCESSORIES**

The following Martin Audio accessories are available for the XE Series:

- HTK00003                      M8 Eye Bolt (galvanised finish)
- XE300FCUK                    Flightcase for Model XE300
- XE500FCUK                    Flightcase for Model XE500

## XE SERIES MONITOR SPECIFICATIONS

	XE300	XE500
TYPE	Two-way, bi-amp/passive Coaxial Differential Dispersion stage monitor	Two-way passive, Coaxial Differential Dispersion stage monitor
FREQUENCY RESPONSE (1)	67 Hz - 18 kHz $\pm$ 3dB; -10 dB @ 55 Hz	62 Hz - 18 kHz $\pm$ 3 dB; -10 dB @ 45 Hz
DRIVERS	LF: 12" (300 mm)/3" (75 mm) voice coil, long dual-gap neodymium motor system HF: 1.4" (35 mm) exit/3" (75 mm) voice coil, titanium dome compression driver	LF: 15" (380 mm)/3.5" (89 mm) voice coil, long dual-gap neodymium motor system HF: 1.4" (35 mm) exit/3" (75 mm) voice coil, titanium dome compression driver
RATED POWER (2)	LF: 350 W AES, 1400 W peak HF: 80 W AES, 320 W peak	LF: 550 W AES, 2200 W peak HF: 80 W AES, 320 W peak
SYSTEM AMPLIFIER	iKON iK42	
MAXIMUM SPL (3)	Bi-amp: 140 dB peak Passive: 139 dB peak	143 dB peak
NOMINAL IMPEDANCE	LF/FR: 6 ohms, HF: 8 ohms	LF: 4 ohms, HF: 8 ohms
DISPERSION(-6 dB)	60° - 30° horizontal, 90° vertical	60° - 30° horizontal, 70° vertical
CROSSOVER	PASSIVE mode: 1.1 kHz internal BI-AMP mode: 1.1 kHz via iK42 amplifier	BI-AMP only: 1.1 kHz via iK42 amplifier
ENCLOSURE	Birch/beech ply and hardwood	
FINISH	Black textured paint	
PROTECTIVE GRILLE	Black perforated steel with scrim cloth backing	
BAFFLE ANGLE	27.5° (feet unextended) 40°(feet extended)	30° (feet unextended) 40°(feet extended)
CONNECTORS	4 x NL4 type	
PIN CONNECTIONS	LF/FR: 1+/-, HF: 2+/-	LF: 1+/-, HF: 2+/-
FITTINGS	2 x pocket handles Protective rubber feet on base and sides Built-in risers 4 x M8 inserts	2 x bar handles Protective rubber feet on base and sides Built-in risers 4 x M8 inserts
DIMENSIONS	(W) 550 mm x (H) 290 mm x (D) 470 mm (W) 21.7 ins x (H) 11.4 ins x (D) 18.5 ins	(W) 635 mm x (H) 364 mm x (D) 583 mm (W) 25.0 ins x (H) 14.3 ins x (D) 22.9 ins
DIMENSIONS (INCLUDING FEET)	(W) 556 mm x (H) 293 mm x (D) 470 mm (W) 21.9 ins x (H) 11.5 ins x (D) 18.5 ins	(W) 641 mm x (H) 367 mm x (D) 583 mm (W) 25.2 ins x (H) 14.4 ins x (D) 22.9 ins
WEIGHT	19 kg (41.9 lbs)	29 kg (63.9 lbs)
ACCESSORIES	Eyebolts	Eyebolts

### NOTES:

1. Measured in half (2pi) space at 2 metres with 1 watt input, using band limited pink noise, then referred to 1 metre.
2. AES Standard ANSI S4.26-1984.
3. Calculated at 1 m.

## IK42 AMPLIFIER

### TECHNICAL SPECIFICATIONS

General	
Number of Output channels	Four
Total power output (iK42)	20,000 watt RMS
Input types	Analogue, AES3, Dante
Control, monitoring & alarm	Ethernet, configurable function volt-free relay and contact closure port
Energy saving modes	Standby and deep sleep, both with auto-sleep timers
System sleep and wakeup	Front panel switch, network command, contact closure and audio detection
Max ambient temperature (full power, no limiting)	40 degC (105 degF)
Audio	
Amplifier topology	Proprietary 5th generation Martin Audio Class D
Amplifier modulation scheme	Low feedback, multiple loop, with feed-forward error correction
Dynamic range (analogue input to speaker output)	>113 dBA typ
Dynamic range (AES3 or Dante input to output)	>114 dBA typ
Frequency response	< 7Hz to >30 kHz, 4 ohms, -2.5 dB
Total harmonic distortion, THD	<0.05% typ, 1 kHz, AES17, 4 ohms
Inter-channel crosstalk (worst combination of channels)	Better than -85 dB at 1 kHz Better than -75 dB at 10 kHz
Slew Rate	>60 V per microsecond typical
Damping factor (ref 8 ohms)	>800 at amplifier output
Maximum analogue input level	+20 dBu
Analogue input sensitivity range for full output	0 dBu to +20 dBu, continuously adjustable
Analogue input	20k ohm, electronically balanced
Analogue link	Directly connected to the analogue input
Analogue ground scheme	AES48 standard compliant
AES3 input	Transformer isolated with active cable equalisation for extended range
AES3 link	Active signal regeneration with automatic direct bypass to the AES3 input if the unit is unpowered
AES3 supported sampling rates	24 kHz to 192 kHz (auto locking)
Digital processing	
Resolution	40 bit, using proprietary LMD (Linea-Micro-Detail) algorithms
Sample rate	96kHz throughout
Special functionality:	Class leading limiter suite (See the 'speaker protection systems' section )
	Hardman crossover filters (Better out of band rejection than Linkwitz-Riley)
	LIR crossover filters (Linear Phase without the compromises of FIR filters)
	FIR Shelving EQ filters (For linear phase filtering)
	Overlays (Twelve additional independent overlays of EQ, Delay and Gain)



Power Output iK42	
Power specification	RMS output power per channel, all channels driven with continuous program material and a nominal ambient temperature of 40 degC / 105 degF
Crest Factor of 4 (12 dB), 2 ohm nominal load	5,000 W
Crest Factor of 2.8 (9 dB), 4 ohm nominal load	3,000 W
Crest Factor of 2 (6 dB), 8 ohm nominal load	1,500 W
Bridged, per channel pair, 4 ohm load	10,000 W
25 V line (CV) operation, Crest Factor 4 (12 dB)	1,250 W
70 V line (CV) operation, Crest Factor 4 (12 dB)	3,500 W
100 V line (CV) operation, Crest Factor 4 (12 dB)	5,000 W
Power Output iK81	
Power specification	RMS output power per channel, all channels driven with continuous program material and a nominal ambient temperature of 40 degC / 105 degF
Crest Factor of 4 (12dB ), 2-Ohm nominal load	1,250 W
Crest Factor of 2.8 (9dB), 4-Ohm nominal load	1,250 W
Crest Factor of 2 (6dB), 8-Ohm nominal load	1,250 W
Bridged, per channel pair, 4 Ohm load	2,500 W
25 V line (CV) operation, Crest Factor 4 (12dB)	625 W
70 V line (CV) operation, Crest Factor 4 (12dB)	1,250 W
100 V line (CV) operation, Crest Factor 4 (12dB)	1,250 W
Power supply	
Topology (main power supply)	3rd generation Series Resonant
Topology (auxiliary and standby supplies)	Low quiescent Eco-Flyback
Internally stored energy	>600 Joules
Mains input voltage range (automatically configured)	85 V to 240 V
Mains input frequency range	47 Hz to 63 Hz
Mains inrush current (max for <10 ms)	6 A at 115 V, 12 A at 230 V
Protection systems	
Note: Under all circumstances the control and protection systems will endeavour to deliver the maximum power possible for a given set of conditions, applying limiters only in extreme circumstances. Muting will only occur when a dangerous situation is detected, normal operation automatically resuming when the condition clears.	
System protection	Speaker protection
Excessive output current	Audio soft-clip limiter
Excessive power supply current	VxLim, Multiband peak limiter
Excessive amplifier section temperature	VxMax, Multiband overshoot limiter
Excessive power supply section temperature	Vx-Xmax, Driver excursion limiter
Excessive DSP section temperature	Vx-Tmax, Driver thermal limiter (long term power limiter)
Mains voltage out of range	DC offset protection
Fan speeds out of range	Excessive HF energy (VHF) limiter
Internal power rails out of range	
Power distribution protection systems	
Mains inrush current limiting (soft start and anti-surge)	
Mains average current limiting (mains breaker / fuse trip protection)	
Randomised initialisation when powered up to reduce the peak power demand in large systems	



Monitoring and logging	
Supply current logged vs time	Number of power cycles counted
Supply voltage logged vs time	Number of mains brownout events counted
Thermal Capacity logged vs time	Fan speeds continuously monitored
Each driver current logged vs time	Fan under-speed events counted
Each driver impedance logged vs time	Various protection mute events counted
Protection limiting for each output logged vs time	Driver Impedance continuously monitored
An inbuilt alarm and notification system can be configured to indicate problems to remote devices either via the network or the Volt-free changeover relay contacts accessibly on the rear panel.	
Physical	
Cooling	Variable speed fans
Airflow	Front to back
Air filtration	Washable media, changeable without the use of tools
Analogue IN and LINK connectors	Genuine Neutrik™ XLR
AES3 IN and LINK connectors	Genuine Neutrik™ XLR
Audio output connector	Genuine Neutrik™ Speakon
Mains input connector	Genuine Neutrik™ 32 A PowerCon
Dante Primary and Secondary	Shielded RJ45
Relay output & contact closure inputs	Phoenix pluggable terminal block
Front panel display	Graphical, backlit, high contrast, daylight visible
Front panel encoders	Two, indented, velocity sensitive
Front panel push buttons	Large, tactile, illuminated
LED indicators	Bright, easily differentiated
Enclosure	Standard 19" 2U (88 mm ) with handles and optional rear support system
Depth (behind rack ears)	357 mm (14")
Net Weight	12.5 kg (27.5 lbs)
Options	
Rear rack support kit	IKRACK

**XE SERIES MONITORS - TECHNICAL DRAWINGS**

**XE300**

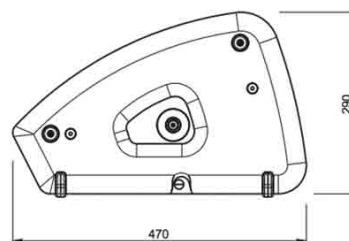
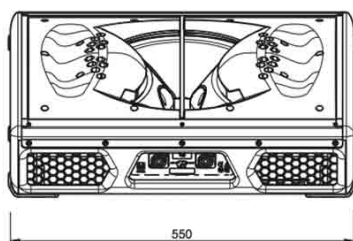
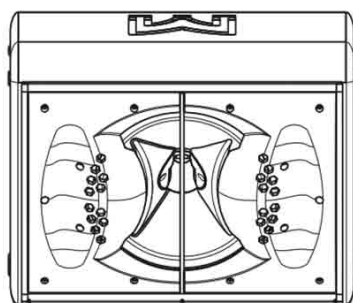

**XE500**

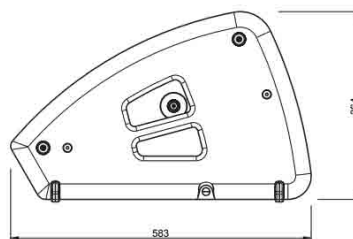
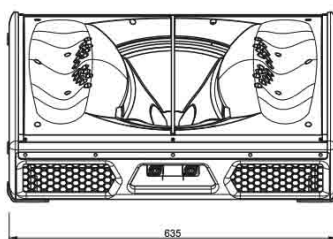
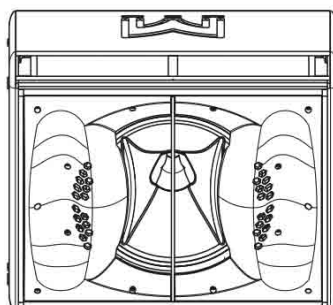



## WARRANTY

Martin Audio XE Series Stage Monitors are warranted against manufacturing defects in materials or craftsmanship over a period of 5 years from the date of original purchase.

During the warranty period Martin Audio will, at its discretion, either repair or replace products which prove to be defective provided that the product is returned in its original packaging, shipping prepaid, to an authorised Martin Audio service agent or distributor.

Martin Audio Ltd. cannot be held responsible for defects caused by unauthorised modifications, improper use, negligence, exposure to inclement weather conditions, act of God or accident, or any use of this product that is not in accordance with the instructions provided by Martin Audio. Martin Audio is not liable for consequential damages.

This warranty is exclusive and no other warranty is expressed or implied. This warranty does not affect your statutory rights.

## COPYRIGHT AND TRADEMARKS

Copyright Martin Audio Ltd. Martin Audio and Coaxial Differential Dispersion are registered trademarks of Martin Audio Ltd and are registered in the United Kingdom, United States and other countries.

All other trademarks and trade names are the property of their respective owners.

2024 © Martin Audio Limited. All rights reserved.



**Martin Audio Limited**

**Century Point**

**Halifax Road**

**Cressex Business Park**

**High Wycombe**

**Buckinghamshire**

**HP12 3SL**

**England**

**UK**

**Telephone: +44 (0)1494 535312**

**Facsimile: +44 (0)1494 438669**

**E-mail: [info@martin-audio.com](mailto:info@martin-audio.com)**

**NORTH AMERICA**

**Telephone: 519 747 5853**

**Facsimile: 519 747 3576**

**E-mail: [info@martin-audio.com](mailto:info@martin-audio.com)**

All information is Copyright © 2024 Martin Audio Ltd.

Copyright Martin Audio Ltd. Martin Audio and Coaxial Differential Dispersion are registered trademarks of Martin Audio Ltd and are registered in the United Kingdom, United States and other countries.

All other trademarks and trade names are the property of their respective owners.

[www.martin-audio.com](http://www.martin-audio.com)