

TH Series

User Guide



TH
SERIES





TH SERIES



Content

Introduction..... 3

Unpacking..... 3

TH Series overview 4

 TH Series 3-way horn-loaded, full range systems..... 5

 THV 5

 THH 6

Accessories 7

 Eye Bolts 7

Safety first..... 8

 Stacking..... 8

 Rigging and suspension 8

Amplification 9

 Choosing a power amplifier..... 9

 Gain Settings..... 9

 Recommended Amplifiers 9

Connections 10

Cable lengths 10

Recommended controllers 10

 DX0.5 10

 DX1.5 11

 DX2 11

System Parameters..... 12

 DX0.5, 1.5 or DX2..... 12

 iK42 (Parameters entered via Vu-Net)*..... 12

 iK42 (Programmed from the Front Panel) 12

Wiring Diagrams 13

 System A- basic set-up bi-amping THV or THH 13

 System B basic bi-amp system using IKON iK42 14

 System C- Introducing Subs 15

 System D- Using an IKON iK42 and SXH218..... 16

Eye Bolt Mounting 17

Specifications..... 18

 Notes 18

Technical Drawings..... 19

 THV 19

 THH 20

Warranty..... 21



Introduction

Thank you for purchasing a Martin Audio TH Series system. The TH Series is a range of portable loudspeaker enclosures designed for a variety of portable sound reinforcement and club applications.

TH products covered in this user's guide include the THV and THH horn-loaded systems

TH Series systems are designed to run bi-amped and should be used with a loudspeaker processors such as the Martin Audio DX0.5, DX1.5 or DX2 or an amplifier with integral DSP such as the iK42

Unpacking

Each Martin Audio TH Series loudspeaker is built to the highest standard and thoroughly inspected before it leaves the factory. After unpacking the system, examine it carefully for any signs of transit damage and inform your dealer if any such damage is found. It is suggested that you retain the original packaging so that the system can be repacked at a future date if necessary.

Please note that Martin Audio and its distributors cannot accept any responsibility for damage to any returned product through the use of non-approved packaging.



TH Series overview

The TH Series is made up of two models, both are 3-way all-horn full-range systems with identical acoustic properties;-

THV

Vertically formatted 15"+10"+1" bi-amplified

THH

Horizontally formatted 15"+10"+1" bi-amplified

TH Series 3-way horn-loaded, full range systems

THV



The THV is very high performance, vertically formatted, all-horn, three-way systems in a single, wide-bandwidth package.

The THV is bi-amplified. New drivers have been developed for improved performance in all bands.

The Hybrid™ low frequency section comprises a horn-loaded 15" (380mm)/4" (100mm) voice coil driver that is reflex loaded to extend the LF output to below the natural cut-off point of the horn. The new LF driver features a water resistant cone and triple roll surround for increased excursion.

The THV mid horn has a unique 'phase-ball' loading device which maintains the constant directivity characteristics of the horn at the upper end of its range. It is driven by a new 10" (250mm) midrange driver with an aluminium demodulating ring for improved high-mid clarity and reduced distortion when driven hard. The 70° x 40° THV HF section features a neodymium 1" (25mm) exit compression driver with a Kapton diaphragm for high sensitivity and extended HF performance.

The internal mid/high passive crossover allows this three-way system to be driven in a bi-amp configuration. The THV is bi-amplified and must be used with a system controller. Martin Audio DX0.5, DX1.5, DX2 or iK42 may be configured to provide the recommended 2-way crossover and limiter functions. Martin Audio DX0.5, DX1.5 or DX2 may also be used to configure THV systems with additional sub-bass cabinets – e.g. THV + SX218 combinations.

THH



The THH is a very high performance, all-horn, three-way system in a single, wide-bandwidth package. The THH offers all the attributes of the standard THV but is horizontally formatted making it suitable for venues with restricted ceiling height.

The THH is bi-amplified and must be used with a system controller. Martin Audio DX0.5, DX1.5 or DX2 system controllers, or iK42 amplifiers may be configured to provide the recommended 2-way crossover and limiter functions.

Martin Audio DX0.5, DX1.5 or DX2 may also be used to configure THV systems with additional sub-bass cabinets – e.g. THH with SX218.

Accessories

Eye Bolts



TH Series speakers have threaded inserts available for flown applications in fixed installations. All cabinets have twelve M10 inserts. The inserts can be used for fitting bespoke flying hardware or for flying using Eye Bolts. These must be forged steel or machined shouldered types certified with a safe working load in excess of the cabinet weight. Do NOT be tempted to use cheap formed steel types commonly available from DIY stores as they are unsafe for flying heavy speaker cabinets. Correctly rated shouldered eye bolts are available from Martin Audio as an optional accessory, part number is as follows:-

M10 (THV, THH) HTK00004



Safety first

It is important that loudspeaker systems are used in a safe manner. Please take some time to review the following points concerning safe use of TH Series loudspeakers.

Professional loudspeakers are capable of producing extremely high sound levels and should be used with care. Hearing loss is cumulative and can result from levels above 90dB if people are exposed for a long period. Never stand close to loudspeakers driven at high level.

Stacking

- Ensure that the floor or stage is level and solid
- Do not stack speakers too high outdoors where winds could topple the stack
- Be aware that speakers producing very high power levels can move or creep. To avoid this, place friction material between the floor and speaker and between each speaker or use strapping to secure the stack.

Rigging and suspension

WARNING: Suspending the system should only be done by qualified personnel following safe rigging practices. Secure fixings to the building structure are vital. Seek help from architects, structural engineers or other specialists if in any doubt.

TH Series enclosures are designed for portable applications, but can be suspended singly by means of the threaded inserts provided. Enclosures are fitted internally with steel corner reinforcement brackets, where necessary, to ensure that each cabinet is strong enough to be hung from its top.

- Never suspend one enclosure from another to form an array or cluster using these fittings
- The common practice of using commercially available eye bolts for suspension should only be undertaken with great caution.
- Only forged or machined shoulder eye bolts should be considered and it is important that the thread length is at least 30mm
- Formed eye bolts i.e. those which are formed from a steel rod bent into an eye are **not** recommended
- Eye bolts are strongest along the thread axis. Angling the enclosure will result in an angle pull and it is important to use eye bolts that are safe in these circumstances.

Amplification

Choosing a power amplifier

Martin Audio loudspeakers are capable of recreating musical dynamics accurately and with incredible impact if powered correctly. Martin Audio loudspeaker power ratings are quoted for AES power - a long-term average power rating with a much closer relation to a music signal than other measurement standards such as RMS, and Peak power – a short-term burst capability.

Moving coil loudspeakers can be run up to their AES power rating continuously and up to the higher Peak power rating for transient musical peaks. All TH Series speakers have a peak power rating four times the long-term AES rating. Ideally you should use an amplifier that can deliver the full peak rating without risk of clipping. This however may be beyond the budget for many so a good compromise is to aim for an amplifier that can deliver at least twice the AES rating.

This should be acceptable for many applications but be aware of the limitations particularly if the system is used with uncompressed live music. In particular it is vital to avoid amplifier clipping, this is possibly the biggest single cause of damage to speaker drivers. The clipped waveform has a colossal harmonic output at ultra-high frequencies all being delivered at the full power capability of the amplifier so speaker damage is extremely likely.

The amplifier selection table below will assist in choosing an amplifier to suit your application at an acceptable price point.

Gain Settings

The vast majority of professional and even budget amplifiers on the market these days have a standard front to back gain regardless of their output power capability. The industry standard gain figure is 32dB which is a gain of X40. This figure is a good balance between enough gain to run that majority of systems without having to drive mixers and any other processing equipment at a level so high that there is a risk of clipping, and not too much gain which would raise the noise floor of the system. When using a DX0.5 or other system processor which has a limiter function you should always use the limiter settings shown in the parameter chart (see the chapter on the DX0.5 Speaker Processor). The limiter threshold is calculated to allow the maximum level from your system without damage and is based on a known amplifier gain setting- 32dB by default. For that reason it is vital that if the amplifier has front panel gain controls they **MUST** be set FULL UP. Lowering them does not offer more protection for your system, it just changes the gain setting of the amplifier so a greater input level is required to obtain the maximum power from the amp. This will make the limiter in the system controller useless as the gain is no longer at the setting for which the threshold has been calculated. For optimum performance always observe the following:-

- **Use a DX0.5, DX1.5, DX2 or high quality loudspeaker processor**
- **Use the published Parameters for the TH range**
- **Use an amplifier with a gain of 32dB (X40)**
- **Always run front panel gain controls full up**
- **Avoid amplifiers that only quote a sensitivity rating; "xxdB for maximum output" (i.e. no published gain setting)**

Recommended Amplifiers

Model	AES Power Rating	Peak Power Rating	Ideal amplifier rating		Minimum rating		Martin Audio amplifiers
			4Ω	8Ω	4Ω	8Ω	
THV LF	750W	3,000W	6,000W	3,000W	3,000W	1,500W	iK42
THV HF	300W	1,200W	2,400W	1,200W	1,200W	600W	iK81, MA5.2K, MA3.0
THV LF	750W	3,000W	6,000W	3,000W	3,000W	1,500W	iK42
THV HF	300W	1,200W	2,400W	1,200W	1,200W	600W	iK81, MA5.2K, MA3.0

Connections

Each connector panel has two Neutrik Speakon connectors wired in parallel with each other. The second connector allows use of a short link lead to power another, parallel TH loudspeaker. The connectors are wired as follows:

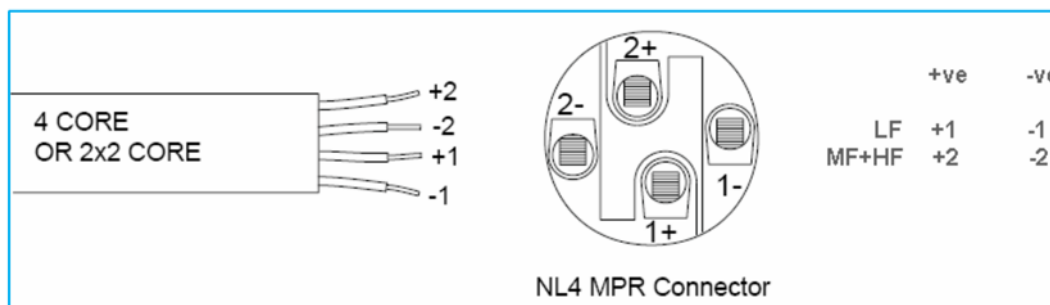

Cable lengths

When connecting Blackline+ systems to an amplifier, it is recommended that the return resistance of the cable used is less than one tenth of the nominal impedance of the system or systems in parallel. The table below gives an indication of the maximum permissible cable runs for various conductor cross-sectional areas.

Conductor CSA	Maximum Cable Run		
	4 ohms	8 ohms	16 ohms
1.0mm ²	11m	22m	44m
1.5mm ²	17m	34m	68m
2.0mm ²	22m	44m	88m
2.5mm ²	29m	58m	116m
4.0mm ²	44m	88m	176m
6.0mm ²	66m	132m	264m

Recommended controllers

Controllers must be used with the bi-amplified THV and THH. Controllers must also be used when adding a subwoofer such as an SX218 to a system as this very high power subwoofer does not include a passive low-pass network.

DX0.5



The DX0.5 is a powerful 2in-6out DSP based audio processing unit for live applications and fixed installations.

The unit is configurable in 5 basic modes (2 x stereo + sub, 3 x stereo, 2 x 2-way + sub, 2 x 3-way and 1 x 6-way). Each input has adjustable gain and delay. Each output consists of a high and low pass filter, 5 bands of parametric equalisation, limiter, delay (adjustable in 2.6 µs steps), gain and polarity controls. A USB Port allows connection to a PC for desk-top control using the dedicated DX0.5 control application available free of charge from www.martin-audio.com.

Please refer to the DX0.5 user guide for further information.

DX1.5



The DX1.5 is a 2 input 6 output digital loudspeaker management system for use in both live applications and fixed installations. Based on a processing platform running at 96kHz the DX1.5 offers unrivalled performance and flexibility.

The DX1.5 has standard routing matrix configurations, such as 2 x 3-way, as well as flexible routing allowing any output to be fed from any input or sum of inputs. Each output consists of a high and low filter, 9 bands of parametric equalisation, limiter delay (adjustable in 0.3 μ s steps), gain and polarity. A PC Binary loader application allows loading of Martin Audio presets in .bin format via the RS232 port

Please refer to the DX1.5 user guide for further information.

DX2



The DX2 embraces the very latest advances in technology to meet the ever increasing demand and expectations placed on professional audio systems setting a new standard in terms of performance, flexibility and ease of use.

Based on a completely new processing platform, running at 96kHz, the DX2 sets a new standard in terms of performance, flexibility and ease of use. The DX2 is a comprehensive, 4 input 8 output, digital loudspeaker management system, capable of being easily configured to meet the most demanding applications in both fixed installation and live touring environments. PC control is available via XTA's Audiocore and iCore platforms allowing quick and easy system configuration and monitoring

Please refer to the DX2.0 user guide for further information.



System Parameters

DX0.5, 1.5 or DX2

	Driver	Gain	Delay	HPF		LPF		EQ			Limiter			
				Freq	Slope	Freq	Slope	Freq	Q	Gain	Thresh	Attack	Rel	Peak
THV THH	15"	2dB	0ms	20Hz	24dB/Oct LR	250Hz	24dB/Oct LR	55Hz	1.4	4dB	6dBu	45ms	X16	9dBu
								170Hz	2.5	3dB				
	10/1"	0dB	3.2ms	250Hz	24dB/Oct LR	22kHz	24dB/Oct LR	231Hz	6.0	-6dB	3dBu	4ms	X16	6dBu
								275Hz	3.6	-3.5dB				
THV THH With Sub	15"	2dB	0ms	20Hz	24dB/Oct LR	250Hz	24dB/Oct LR	55Hz	1.4	4dB	6dBu	45ms	X16	9dBu
								170Hz	2.5	3dB				
	10/1"	0dB	3.2ms	250Hz	24dB/Oct LR	22kHz	24dB/Oct LR	231Hz	6.0	-6dB	3dBu	4ms	X16	6dBu
								275Hz	3.6	-3.5dB				
							655Hz	4.0	2.5dB					
							1KHz	3.0	-1dB					

iK42 (Parameters entered via Vu-Net)*

	Driver	Gain	Delay	HPF		LPF		EQ			VX Limiter		Tmax Limiter		
				Freq	Slope	Freq	Slope	Freq	Q	Gain	Thresh	Overshoot	thresh	Attack	Release
THV THH	15"	2dB	0ms	20Hz	24dB/Oct LR	250Hz	24dB/Oct LR	55Hz	1.9	4dB	78V	3dB	58V	12s	X2
								170Hz	3.4	3dB					
	10/1"	0dB	3.2ms	250Hz	24dB/Oct LR	22kHz	24dB/Oct LR	231Hz	7.2	-6dB	49V	6dB	35V	3s	X4
								275Hz	4.8	-3.5dB					
THV THH With Sub	15"	2dB	0ms	20Hz	24dB/Oct LR	250Hz	24dB/Oct LR	55Hz	1.9	4dB	78V	3dB	58V	12s	X2
								170Hz	3.4	3dB					
	10/1"	0dB	3.2ms	250Hz	24dB/Oct LR	22kHz	24dB/Oct LR	231Hz	7.2	-6dB	49V	6dB	35V	3s	X4
								275Hz	4.8	-3.5dB					
							655Hz	5.5	2.5dB						
							1KHz	4.3	-1dB						

*Note that Factory presets are available in Vu-Net to load parameters for THV and THH into an iK42 so it shouldn't be necessary to manually program an amplifier.

iK42 (Programmed from the Front Panel)

	Driver	Gain	Delay	HPF		LPF		EQ			VX Limiter		Tmax Limiter		
				Freq	Slope	Freq	Slope	Freq	Q	Gain	Thresh	Overshoot	thresh	Attack	Release
THV THH	15"	2dB	0ms	20Hz	24dB/Oct LR	202Hz	24dB/Oct LR	55Hz	1.9	4dB	82V	3dB	58V	12s	X2
								140Hz	3.4	3dB					
	10/1"	0dB	3.2ms	202Hz	24dB/Oct LR	22kHz	24dB/Oct LR	297Hz	4.8	-3.5dB	51V	6dB	36V	3s	X4
								655Hz	5.5	2.5dB					
THV THH With Sub	15"	2dB	0ms	80Hz	24dB/Oct LR	202Hz	24dB/Oct LR	55Hz	1.9	4dB	82V	3dB	58V	12s	X2
								140Hz	3.4	3dB					
	10/1"	0dB	3.2ms	202Hz	24dB/Oct LR	22kHz	24dB/Oct LR	297Hz	4.8	-3.5dB	51V	6dB	36V	3s	X4
								655Hz	5.5	2.5dB					
							1KHz	4.3	-1dB						

Wiring Diagrams

There are several ways that TH systems can be configured so we will now look at some practical wiring examples for the most common system configurations.

System A- basic set-up bi-amping THV or THH

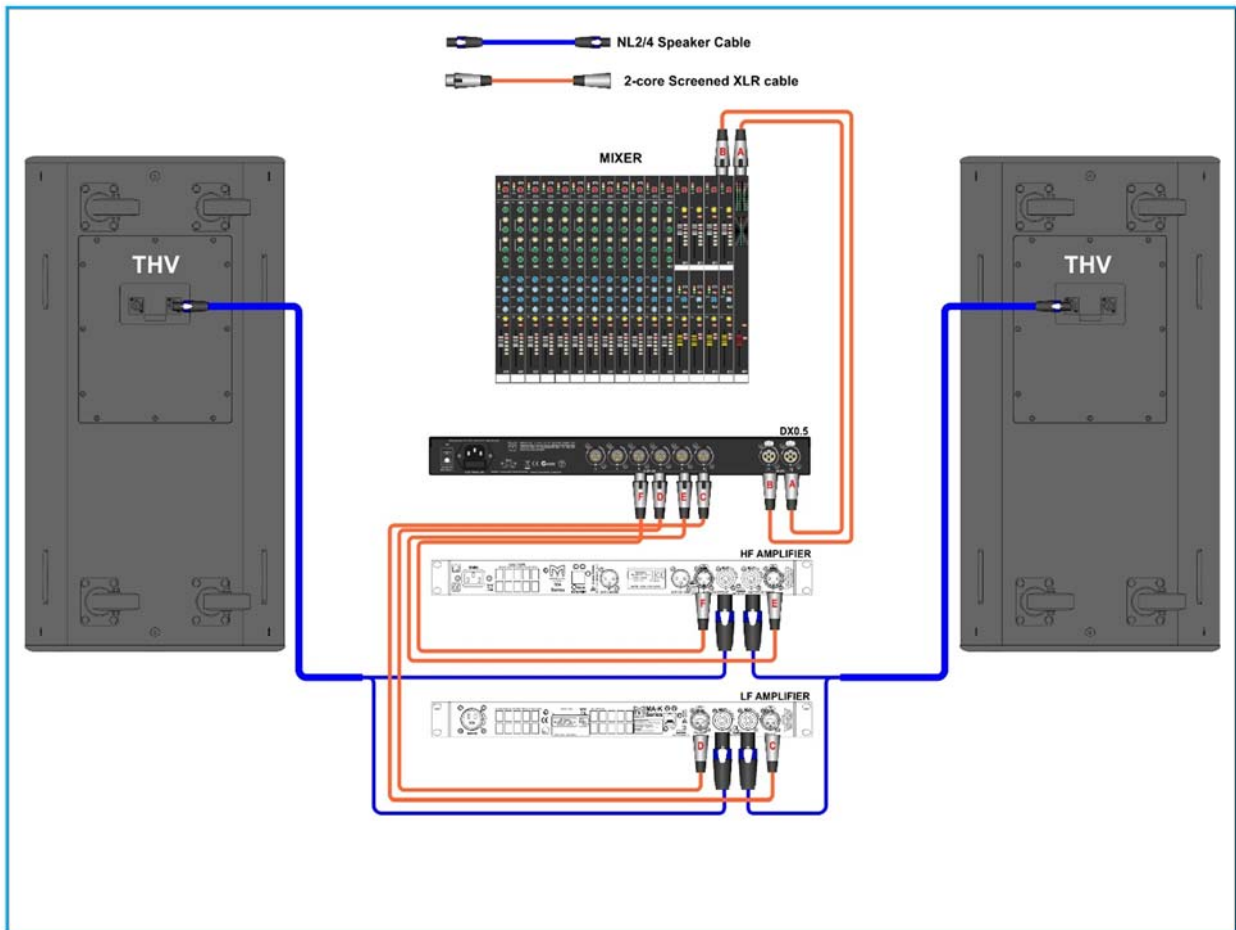

This is the most simple system set up for stereo operation, connecting from your source, often a mixer, straight to a DX0.5 (or other system processor) using balanced XLR "microphone" cables. From the DX0.5 we take four outputs, two low frequency and two high frequency and these are routed to the two amplifiers. We then use a speaker cable that combines two Neutrik NL2 or NL4 Speakon connectors into a single 4-core speaker cable to go from the amplifier outputs to the TH speaker inputs. This could also be achieved with a custom patch panel using NL4 panel connectors with short speaker cables routed from pins 1+/- and 2+/- on the panel to the high and low frequency amplifiers. This will allow a standard 4-core speaker cable can be used between the panel and TH speaker.

See the chapter on amplifier selection to choose the most appropriate amplifier for use with the TH cabinet.

System B basic bi-amp system using IKON iK42

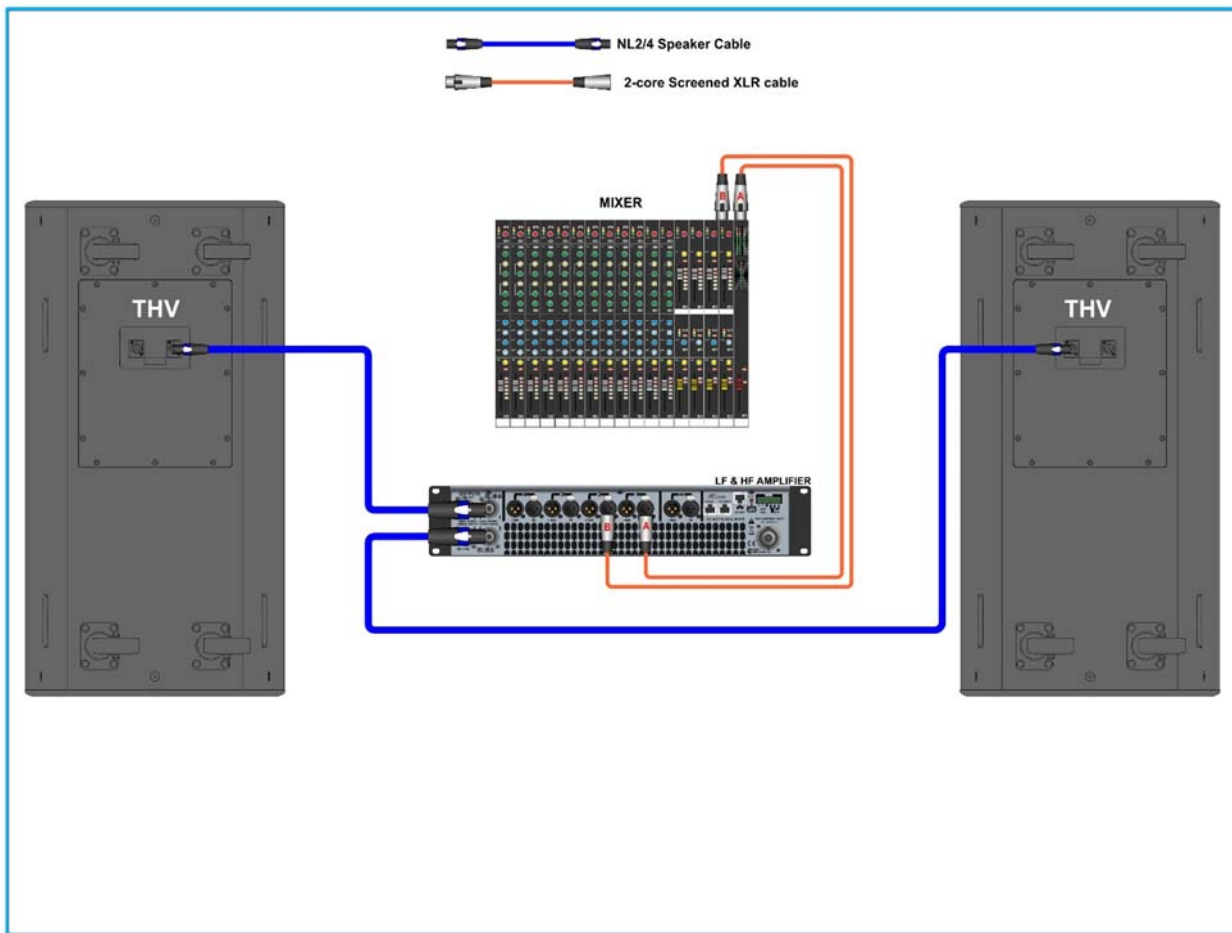

This system is similar to System A running a stereo pair of THV (or THH) bi-amplified. This time we have used an iK42 amplifier from the IKON range. This makes system wiring extremely simple. First we can disregard the loudspeaker processor as the amplifier has on-board DSP and factory presets are available in Vu-Net to add the correct parameters to each channel. Secondly, the amplifier has four channels so only a single amp is required to drive a stereo pair of THV (or THH), in addition the output wiring combines amplifier channels onto single NL4 connectors so output 2 is available on both pins 1+/- on channel 2 NL4 and also on pins 2+/- on output channel 1 NL4. Likewise, output channel 4 appears on channel 4 NL4 and channel 3 NL4 on pins 2+/-.

This makes driving bi-amped cabinets very simple as a standard 4-core NL4 speaker cable can be used straight from the amplifier to the THV. No special speaker cables or patch panels are necessary.

System C- Introducing Subs

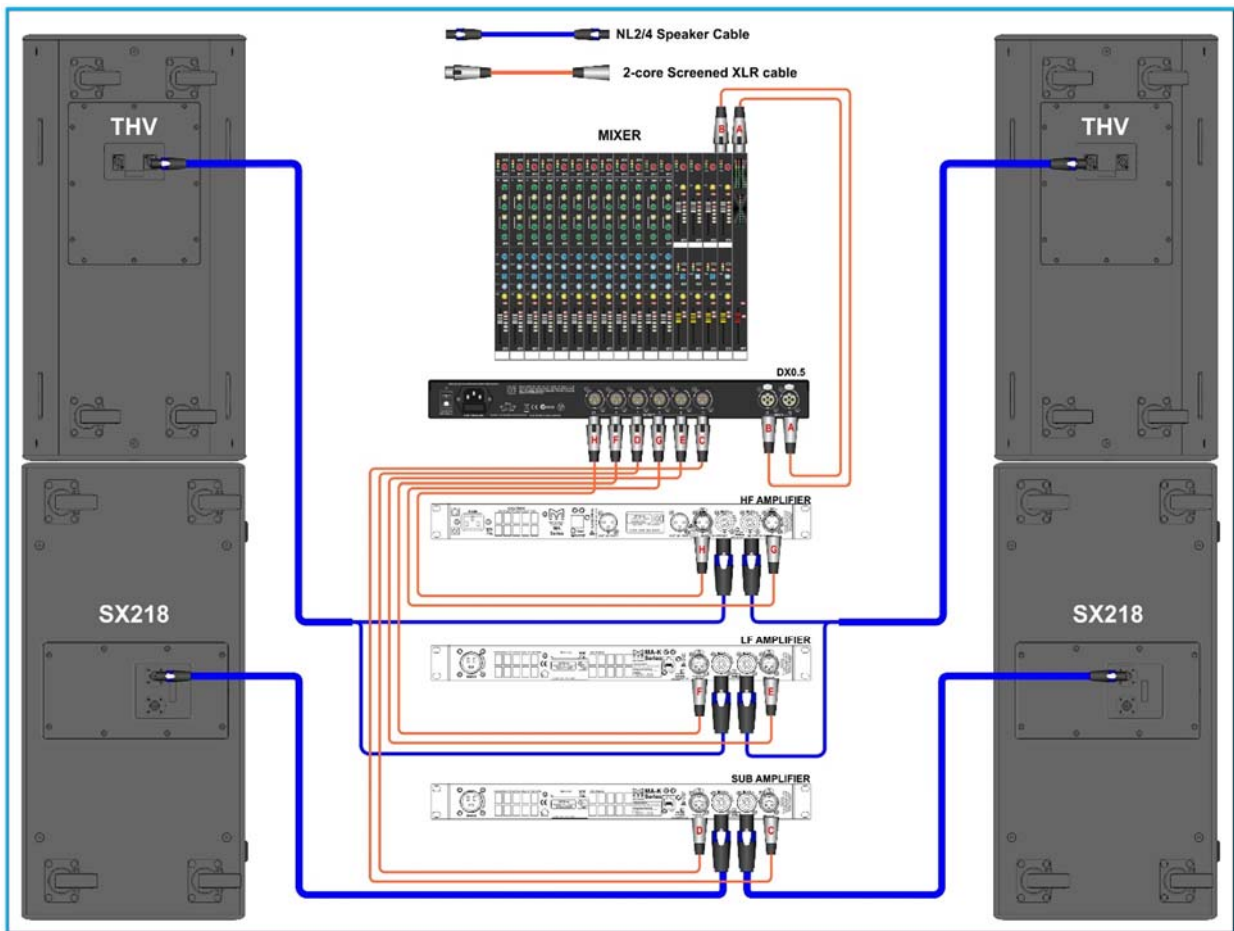

This system adds a pair of subwoofers to enhance the extreme sub frequency response of the system. On this example we have used the SX218 twin 18" direct radiating ported subwoofer. The Martin Audio DX0.5 is again used for system processing, this time using all six outputs to provide left and right outputs for sub, low and high frequencies. A DX1.5 or DX2 may also be used or even a third party processor, parameters to program these are available in spreadsheet form on the Loudspeaker Settings page on the Martin Audio website.

As well as applying the recommended equalisation the processor adds a limiter in the final stage of processing to protect the system from being damaged by being over-driven.

The XLR feeds from the mixer go to the inputs of the DX0.5, the DX0.5 outputs should be connected to the amplifier inputs with short XLR cables. As with the basic system, a cable combines the outputs from the HF and LF amplifiers into a single speaker cable to connect to the THV (or THH).

An additional amplifier is required, this is also fed from the processor and the outputs go directly to the SX218 with standard NL4 speaker cables.

System D- Using an IKON iK42 and SXH218

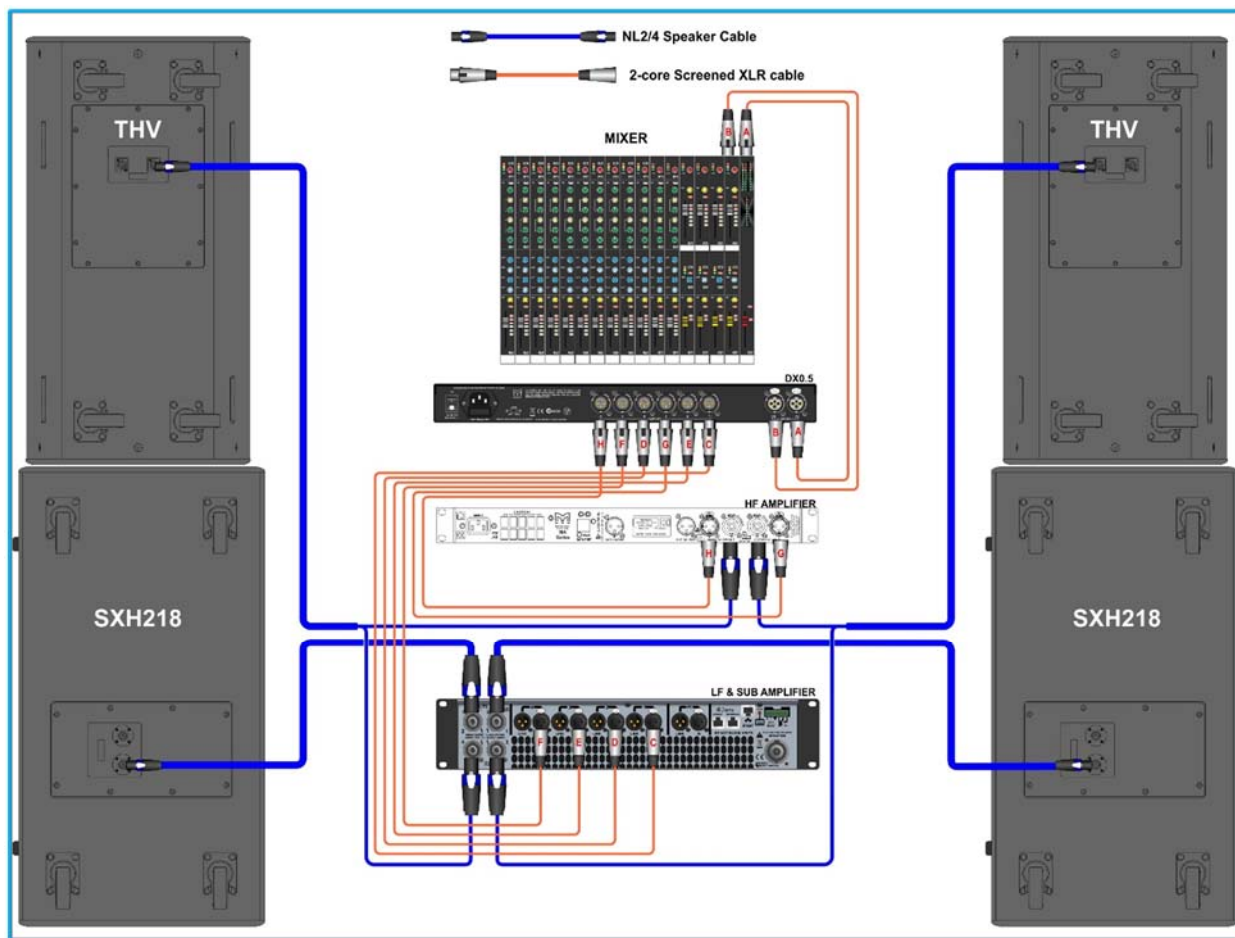

This system is similar to the previous system in that it uses a pair of THV (or THH) and a pair of subwoofers but this time using the SXH218 Hybrid[®] loaded 2 x 18" sub for ultimate sub frequency reproduction and uses one of the Martin Audio IKON iK42 four channel amplifiers to drive the low frequency of the THV and the SXH218s for a neat solution avoiding having to add a third amplifier. Channels 1 and 2 drive the LF of the THV and channel 3 and 4 drive the SXH218. A separate, smaller amplifier is deployed to drive the HF which doesn't require the same power level as the LF and sub.

As with the previous system, there are left and right connections from the mixer to the input of the DX0.5 (or DX1.5, DX2). Output Channels 3 and 6 on the DX0.5 connect to inputs A and B on the amplifier driving the THV high frequency using a pair of short XLR cables. Four more XLR cables connect from outputs 1, 2, 4 & 5 on the DX0.5 to the inputs of the iK42.

Whilst we have used the DX0.5 this wouldn't strictly be required for the LF and Sub as the iK42 has on-board DSP. Processing would however be required for the feed to the amplifier driving the HF unless this also has on-board DSP.

Speaker wiring as before uses a custom cable to combine the LF and HF feeds onto a single 4-core cable (or a patch panel could be used), this cable is fed to the THV. Separate standard NL4 cables go from outputs 1 and 2 to the SXH218s.

Eye Bolt Mounting

All TH systems have threaded inserts rated for flown installations. Both TH speaker enclosures have M10 threaded inserts. Most commonly these are used in conjunction with shouldered eye bolts for suspending the cabinets using appropriately rated chain or steel wire. Martin Audio's HTK00004 (M10) are rated for use in flown applications. Note that if you plan to use alternative eye bolts these must be shouldered cast steel or machined NOT formed steel types commonly available from DIY stores. They must have a safe working load rating compatible with the weight of the cabinets.



The THV enclosure is designed for use in 'Portrait' and the THH in 'landscape' format,

We recommend using a minimum of four eye bolts with which to suspend the cabinet irrespective of which orientation is used. In most applications two eye bolts are used as the primary support left and right. A third attaches to the rear of the cabinet and is used to adjust the down-tilt of the cabinet as required. The fourth eye bolt is used to attach a secondary safety line which should be attached to a secure mounting point which is independent of the primary flying point- round a girder or similar.



Specifications

TYPE	Three-way bi-amp trapezoid Hybrid® fully horn loaded
FREQUENCY RESPONSE (5)	50Hz-18kHz ± 3dB
DRIVERS	15" (380mm)/4" (100mm) coil bass driver 10" (250mm)/2.5" (63.5mm) coil mid driver 1" (25mm) exit HF compression driver
RATED POWER (2)	LF: 750W AES, 3000W peak MF + HF: 300W AES, 1200W peak
RECOMMENDED AMPLIFIER	iK42 or MA3.0
SENSITIVITY (6)	LF: 104dB, MF + HF: 104dB
MAXIMUM SPL (9)	133dB continuous, 139dB peak
NOMINAL IMPEDANCE	LF: 8 ohms, MF + HF: 8 ohms
DISPERSION (-6dB)	70° horizontal, 40° vertical
CROSSOVER	200Hz active, 2kHz passive
ENCLOSURE	250 litre, multi-laminate birch ply
FINISH	Textured black paint
PROTECTIVE GRILLE	Black perforated steel
CONNECTORS	2 x Neutrik NL4
PIN CONNECTIONS	LF+,- : 1+,1-, (MF + HF) +,- : 2+,2-
FITTINGS	12 x M10 inserts 4 x 4" (100mm) castors, 4 x pocket handles
DIMENSIONS (inc wheels)	(W) 558mm x (H) 1067mm x (D) 780mm (908mm) (W) 22ins x (H) 42ins x (D) 30.7ins (35.7ins)
WEIGHT	77.5kg (170.5lbs)

Notes

- (1) Measured on-axis in half (2pi) space at 2 metres, then referred to 1 metre.
- (2) AES Standard ANSI S4.26-1984.
- (3) Measured in half (2pi) space at 2 metres with 1 watt input, using band limited pink noise, then referred to 1 metre.
- (4) Measured in half (2pi) space at 2 metres using band limited pink noise, then referred to 1 metre.
- (5) Measured on-axis in open (4pi) space at 2 metres, then referred to 1 metre.
- (6) Measured in open (4pi) space at 2 metres with 1 watt input, using band limited pink noise, then referred to 1 metre.
- (7) Measured in open (4pi) space at 2 metres using band limited pink noise, then referred to 1 metre.
- (8) Measured in open (4pi) space at 2 metres with 2.83v input, using band limited pink noise, then referred to 1 metre.
- (9) Calculated at 1 metre.
- (10) Measured in half (2pi) space at 2 metres with 2.83V input, using band limited pink noise, then referred to 1 metre.

Technical Drawings

THV

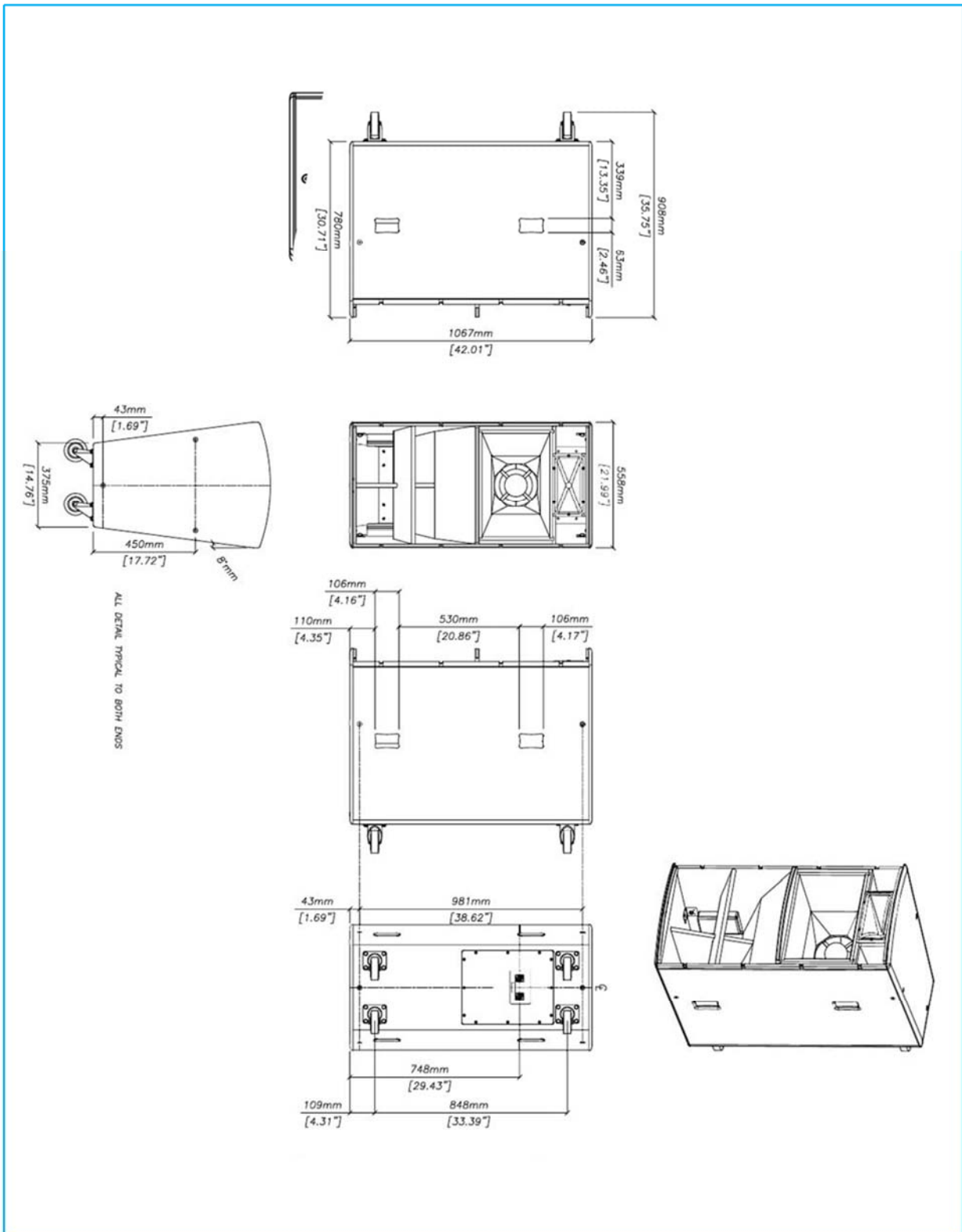

THH

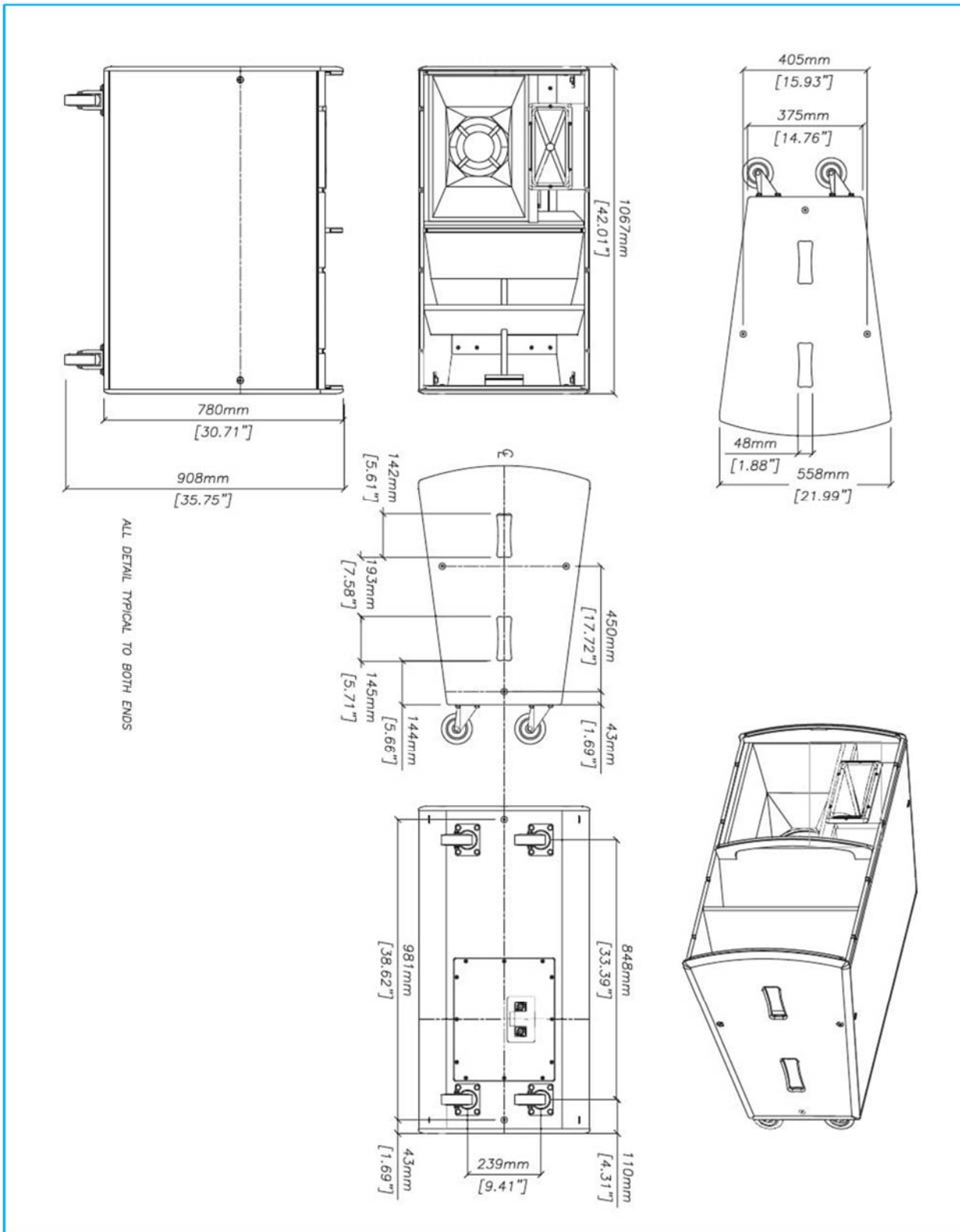



Warranty

Martin Audio TH Loudspeaker Systems are warranted against manufacturing defects in materials or craftsmanship over a period of 5 years from the date of original purchase.

During the warranty period Martin Audio will, at its discretion, either repair or replace products which prove to be defective provided that the product is returned in its original packaging, shipping prepaid, to an authorised Martin Audio service agent or distributor.

Martin Audio Ltd. cannot be held responsible for defects caused by unauthorised modifications, improper use, negligence, exposure to inclement weather conditions, act of God or accident, or any use of this product that is not in accordance with the instructions provided by Martin Audio.

Martin Audio is not liable for consequential damages.

This warranty is exclusive and no other warranty is expressed or implied. This warranty does not affect your statutory rights.



Martin Audio Limited
Century Point
Halifax Road
Cressex Business Park
High Wycombe
Buckinghamshire
HP12 3SL
England

UK
Telephone: +44 (0)1494 535312
Facsimile: +44 (0)1494 438669
E-mail: info@martin-audio.com

NORTH AMERICA
Telephone: 519 747 5853
Facsimile: 519 747 3576
E-mail: info@martin-audio.com

All information is Copyright © 2018 Martin Audio Ltd.

Martin Audio, the Martin Audio logo and TH are registered trademarks of Martin Audio Ltd. in the United Kingdom, United States and other countries; all other Martin Audio trademarks are the property of Martin Audio Ltd.

All other trademarks and trade names are the property of their respective owners.

www.martin-audio.com
