

HYDRO BEAM CMY

User Instructions

©2026 ADJ Products, LLC all rights reserved. Information, specifications, diagrams, images, and instructions herein are subject to change without notice. ADJ Products, LLC logo and identifying product names and numbers herein are trademarks of ADJ Products, LLC. Copyright protection claimed includes all forms and matters of copyrightable materials and information now allowed by statutory or judicial law or hereinafter granted. Product names used in this document may be trademarks or registered trademarks of their respective companies and are hereby acknowledged. All non-ADJ Products, LLC brands and product names are trademarks or registered trademarks of their respective companies.

ADJ Products, LLC and all affiliated companies hereby disclaim any and all liabilities for property, equipment, building, and electrical damages, injuries to any persons, and direct or indirect economic loss associated with the use or reliance of any information contained within this document, and/or as a result of the improper, unsafe, insufficient and negligent assembly, installation, rigging, and operation of this product.

ADJ PRODUCTS LLC World Headquarters

6122 S. Eastern Ave. | Los Angeles, CA 90040 USA
 Tel: 800-322-6337 | www.adj.com | lsupport@adj.com

ADJ Supply Europe B.V.

Junostraat 2 | 6468 EW Kerkrade | Netherlands
 Tel: +31 45 546 85 00 | www.americandj.eu | service@americandj.eu

Europe Energy Saving Notice

Energy Saving Matters (EuP 2009/125/EC)

Saving electric energy is a key to help protecting the environment. Please turn off all electrical products when they are not in use. To avoid power consumption in idle mode, disconnect all electrical equipment from power when not in use. Thank you!

DOCUMENT VERSION



Due to additional product features and/or enhancements, an updated version of this document may be available online.

Please check www.adj.com for the latest revision/update of this manual before beginning installation and/or programming.

Date	Document Version	Software Version >	DMX Channel Mode	Notes
03/23/26	1	1.00	20 / 24 Ch	Initial Version
06/29/26	1.1	N/C	No Change	Updated: System Menu, DMX Traits, Specifications; Added Index

CONTENTS

Introduction	4
Features	5
IP65 Rated	6
Overview	7
Torque Screws	9
IP Test Parameters	10
Colors and Gobos	12
Installation Guidelines	12
Aria Setup and Guidelines	17
System Menu	21
Dimmer Curves Dimmer Modes	24
DMX Setup	25
DMX Traits	26
Primary-Secondary Setup Multi-Unit Power-Linking	31
Remote Device Management (RDM)	32
Maintenance Guidelines	33
Error Codes	34
Specifications	35
Dimensional Drawings	36
FCC Statement	37
Index	38

INFORMATION

INTRODUCTION

Please read and understand the instructions in this manual carefully and thoroughly before attempting to operate this device. These instructions contain important safety and use information.

This product is intended for use by professionally trained personnel only, and is not suitable for private use.

Unpacking

Every device has been thoroughly tested and has been shipped in perfect operating condition. Carefully check the shipping carton for damage that may have occurred during shipping. If the carton is damaged, carefully inspect the device for damage, and be sure all accessories necessary to install and operate the device have arrived intact. In the event damage has been found or parts are missing, please contact our customer support team for further instructions. Please do not return this device to your dealer without first contacting customer support. Please do not discard the shipping carton in the trash. Please recycle whenever possible.

Parts: To purchase parts online visit:

<http://parts.adj.com> (US)

<http://www.adjparts.eu> (EU)

ADJ SERVICE USA - Monday - Friday 8:00am to 4:30pm PST

Voice: 800-322-6337 | support@adj.com

ADJ SERVICE EUROPE - Monday - Friday 08:30 to 17:00 CET

Voice: +31 45 546 85 60 | support@adj.eu

ADJ PRODUCTS LLC USA

6122 S. Eastern Ave. Los Angeles, CA. 90040

323-582-2650 | www.adj.com | info@adj.com

ADJ SUPPLY Europe B.V

Junostraat 2 6468 EW Kerkrade, The Netherlands

+31 (0)45 546 85 00 | www.adj.eu | info@adj.eu

ADJ PRODUCTS GROUP Mexico

AV Santa Ana 30 Parque Industrial Lerma, Lerma, Mexico 52000

+52 (728) 282-7070

LIMITED WARRANTY

For up-to-date warranty information regarding your device, please visit ADJ's warranty information page online or scan the QR codes below.



USA: <https://www.adj.com/pages/warranty-information>



EU: https://www.adj.eu/terms_and_conditions

It is strongly recommended to power the fixture down completely when not in use. Doing so will reduce wear on the fixture due to sustained or extended operational periods, thereby maximizing its operational lifespan.

FEATURES

- IP65-rated beam fixture designed for demanding outdoor and indoor environments
- Ideal for outdoor festivals, stadium tours, theme parks, and large-scale events
- Powered by OSRAM Sirius HRI 310W PRO discharge lamp
- Ultra-bright, razor-sharp 2° beam that cuts through ambient light, haze, and fog
- High-quality glass lens and advanced internal optics for consistent output and exceptional beam definition
- Motorized focus with 16-bit precision for crisp projections at any distance
- Advanced CMY color mixing system for smooth transitions and limitless hues
- 14-position dichroic color wheel including CTO (3200K), CTB (9000K), and UV filters
- 17 static GOBOs including four beam reducers, with shake and split-color effects
- Two rotating prisms (16-facet circular and 6-facet linear) — usable individually or overlaid
- Frost filter for soft-edged wash effects
- 3-phase high-speed pan and tilt motors for fast, precise movement
- DMX512 with RDM (Remote Device Management) support
- Integrated Aria X2 wireless DMX and fixture management for streamlined setup and remote configuration
- Robust construction with full IP65 dust and water protection
- Combines rugged reliability with refined professional performance for touring and temporary events

IP65 RATED

The **International Protection (IP)** rating system is commonly expressed as “**IP**” (Ingress Protection) followed by two numbers (i.e. IP65), where the numbers define the degree of protection. The first digit (Foreign Bodies Protection) indicates the extent of protection against particles entering the fixture, and the second digit (Water Protection) indicates the extent of protection against water entering the fixture. An **IP65** rated lighting fixture is designed and tested to protect against the ingress of dust (6), and low-pressure water jets from any direction (5).

NOTE: THIS FIXTURE IS INTENDED FOR TEMPORARY OUTDOOR USE ONLY!

Maritime/Coastal Environment Installations: A coastal environment is seaside adjacent, and caustic to electronics through exposure to atomized salt-water and humidity, whereas maritime is anywhere within 5-miles of a coastal environment.



NOT suitable for maritime/coastal environment installations. Installing this fixture in a maritime/coastal environment may cause corrosion and/or excessive wear to the interior and/or exterior components of the fixture. Damages and/or performance issues resulting from installation in a maritime/coastal environment will void the manufacturer’s warranty, and will NOT be subject to any warranty claims and/or repairs.

Maritime installations require additional preparation, and additional service intervals may be needed given the maritime use. In general, IP ratings presuppose freshwater conditions VS maritime conditions, which are typically more “caustic” to IP fixtures (both internally and externally). A duty-cycle may also be needed when units are not in use. During times of high humidity and colder temperatures, condensation may occur internally so the fixture may require a duty-cycle to bring it up to running temperature, allowing any accumulation of moisture to be expelled via the vent valve. Recommendations can change based on installation environmental circumstances. A waterproof dome or similar device is recommended for use in permanent outdoor installations. When using a dome, refer to manufacturer recommendations for duty-cycle.

NOTE: NOT ALL FEATURES LISTED ARE AVAILABLE ON ALL FIXTURES; THE FOLLOWING INSTRUCTIONS MAY NOT APPLY. CONTACT SUPPORT FOR ADDITIONAL DETAILS.

Exterior Maintenance: Inspect the exterior every 30-days. The unit must be powered off/disconnected. Inspect optics to determine if the lens is obstructed, then clean optics and chassis accordingly. Based on initial finding, schedule maintenance accordingly, keeping in mind that exterior maintenance will be required. Even if the luminaires are NOT in use, maintenance will still be needed given its location (exterior use). The use of a durable type of wax on the chassis is recommended since it will help prevent contaminant build up. Inspect both power and data lines for any signs of contaminants or corrosion. Periodically reapply di-electric grease, especially in coastal environments. If any signs of corrosion/contaminants are present, clean thoroughly, and/or replace connectors, then reapply di-electric grease. Typically, this should be done annually, or any time an opportunity presents itself. As a preventive measure, annual replacement of both vent valves is recommended. The vent valve membrane can become contaminated and/or clogged causing improper venting of humidity within the luminaire. Inspect all mounting hardware as a precaution.

Interior Maintenance: Inspect the interior every 30-days. The unit must be powered off/disconnected.

- Inspect zoom/focus mechanism, clean optics, lubricate linear bearings (Krytox oil) as needed, inspect belts for wear
- Inspect all rotating effect wheels, manually rotate them, note any resistance
- Inspect all remaining rotating belts for any wear
- Inspect all fans, clean as needed, check rotation, check connections
- Inspect CMY module, manually move flags and check for signs of resistance, and if needed, clean guide rods first, then reapply a thin layer of grease (moly lube)
- Clean interior with low-volume compressed air, then clean optics prior to reassembly of head covers

Although the base has limited moving parts, the pan belt should also be inspected for wear. Remember to always perform an IP test anytime a cover is removed.

There is no specific time frame regarding the routine replacement of parts such as belts/stepper motors, PCBs, or LEDs. These items should only be replaced on an as needed bases, except for cooling fans, which should be replaced once the luminaries reach 10,000-hours. This is a prophylactic measure intended to keep the unit running as cool as possible, insuring proper function of all internal components. A complete service breakdown is available, please contact service@adj.com for any needed parts or manuals.

SAFETY GUIDELINES

FOR YOUR OWN PERSONAL SAFETY, PLEASE READ AND UNDERSTAND THIS MANUAL COMPLETELY BEFORE ATTEMPTING TO INSTALL, OPERATE, OR SERVICE THIS FIXTURE.

To guarantee smooth operation, it is important to follow all instructions and guidelines in this manual. ADJ Products, LLC is not responsible for injury and/or damages resulting from the misuse of this fixture due to the disregard of the information printed in this manual. Only qualified and/or certified personnel should perform installation of this fixture, and only the original rigging parts included with this fixture should be used for installation. Any modifications to the fixture and/or the included mounting hardware will void the manufacturer's warranty and increase the risk of damage and/or personal injury.



PROTECTION CLASS 1 – FIXTURE MUST BE PROPERLY GROUNDED



THERE ARE NO USER-SERVICEABLE PARTS INSIDE THIS UNIT. DO NOT ATTEMPT ANY REPAIRS YOURSELF; DOING SO WILL VOID THE MANUFACTURER'S WARRANTY. DAMAGES RESULTING FROM MODIFICATIONS TO THIS FIXTURE AND/OR THE DISREGARD OF SAFETY INSTRUCTIONS AND GUIDELINES IN THIS MANUAL VOID THE MANUFACTURER'S WARRANTY AND ARE NOT SUBJECT TO ANY WARRANTY CLAIMS AND/OR REPAIRS.



**DO NOT PLUG THE FIXTURE INTO A DIMMER PACK!
NEVER OPEN THIS FIXTURE WHILE IN USE!
UNPLUG POWER BEFORE SERVICING THE FIXTURE!
NEVER TOUCH THE FIXTURE DURING OPERATION AS IT MAY BE HOT!**

Maximum ambient temperature is T_a : 40°C. DO NOT operate the fixture where the temperature is higher than this. The unit surface temperature may reach up to 75°C. DO NOT touch the housing with bare hands during operation. Turn off the power and allow about 15 minutes for the unit to cool down before replacing the lamp or servicing.

KEEP FLAMMABLE MATERIALS AT LEAST 1 M (3.3 FT) AWAY FROM THE FIXTURE!



ENSURE ALL CONNECTIONS AND END CAPS ARE PROPERLY SEALED WITH DIELECTRIC GREASE (AVAILABLE AT MOST ELECTRICAL SUPPLIERS) TO PREVENT WATER CORROSION AND/OR ELECTRICAL SHORT CIRCUITS.



IF THE FIXTURE IS EXPOSED TO ENVIRONMENTAL TEMPERATURE CHANGES (SUCH AS RELOCATION FROM A COLD OUTDOOR TO A WARM INDOOR ENVIRONMENT), DO NOT POWER THE FIXTURE ON IMMEDIATELY. INTERNAL CONDENSATION CAN CAUSE DAMAGE. LEAVE THE FIXTURE POWERED OFF UNTIL IT HAS REACHED ROOM TEMPERATURE BEFORE POWERING ON.

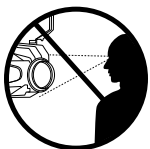

NEVER LOOK DIRECTLY INTO THE LIGHT SOURCE! RISK OF RETINA INJURY – MAY CAUSE BLINDNESS! SENSITIVE PERSONS MAY SUFFER AN EPILEPTIC SHOCK!

SAFETY GUIDELINES

! CAUTION

HIGH INTENSITY ULTRAVIOLET LIGHT

AVOID DIRECT EYE & SKIN EXPOSURE.
WEAR PROPER EYE & SKIN PROTECTION.
SEE MANUAL FOR SAFETY INSTRUCTIONS



RISK GROUP 3 – RISK OF EXPOSURE TO ULTRAVIOLET (UV) RADIATION! THE FIXTURE EMITS HIGH-INTENSITY ULTRAVIOLET UV LIGHT WHEN THE UV COLOR FILTER IS USED. WEAR PROPER EYE AND SKIN PROTECTION. AVOID PROLONGED PERIODS OF EXPOSURE TO THE UV COLOR FILTER. AVOID WEARING WHITE CLOTHING AND/OR USING UV PAINTS ON SKIN.

AVOID DIRECT EYE AND/OR SKIN EXPOSURES AT DISTANCES LESS THAN 11FT. (3.3M). DO NOT OPERATE THE FIXTURE WITH DAMAGED OR MISSING EXTERNAL COVERS. DO NOT LOOK DIRECTLY INTO THE UV LIGHT OR VIEW IT WITH OPTICAL INSTRUMENTS THAT MAY CONCENTRATE THE LIGHT/RADIATION OUTPUT. INDIVIDUALS SUFFERING FROM EYE CONDITIONS, SUNLIGHT EXPOSURE DISORDERS, OR USING PHOTSENSITIVE MEDICATION MAY EXPERIENCE DISCOMFORT IF EXPOSED TO THE ULTRAVIOLET LIGHT EMITTED FROM THE UV FILTER.

DO NOT shake the fixture; avoid brute force when installing or operating the fixture.

DO NOT operate the fixture if the power cord has become frayed, crimped, or damaged, or if any power cord connectors are damaged and do not insert securely. Never force a power cord connector into the fixture. Replace damaged power cords immediately with a new one of similar power rating.

DO NOT block any ventilation slots. These must remain clean and unobstructed. Allow a minimum clearance of 7.9 in (20 cm) between the fixture and any wall or other device for proper cooling.

When installing the fixture in a suspended environment, always use mounting hardware no less than M10 x 25 mm and attach an appropriately rated safety cable.

ALWAYS disconnect the fixture from the main power source before performing any service or cleaning procedure. Only handle the power cord by the plug; never pull the cord itself.

During initial operation, a light smoke or odor may emit from the fixture. This is normal and caused by excess paint burning off from the heat of the lamp. It will gradually decrease over time.

Consistent operational breaks are recommended to ensure long-term reliable performance.

Only use the original packaging and materials when transporting the fixture for service.

The light source contained in this luminaire shall only be replaced by the manufacturer, a qualified service agent, or a similarly qualified technician.

The luminaire is intended for professional use only.

OVERVIEW

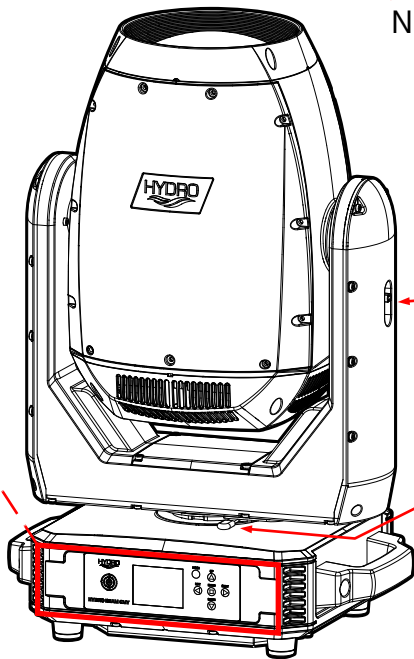
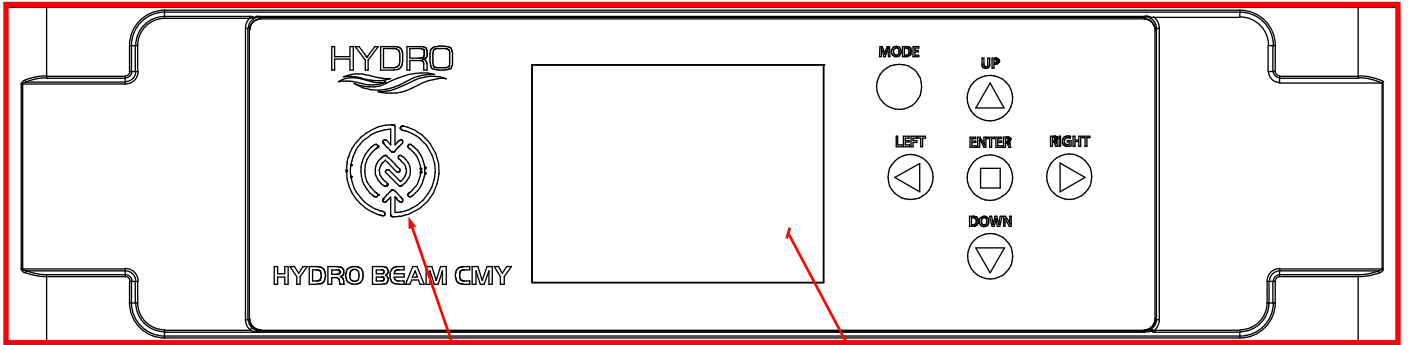

NFC Access Point LCD Display

Tilt-Lock

Pan-Lock

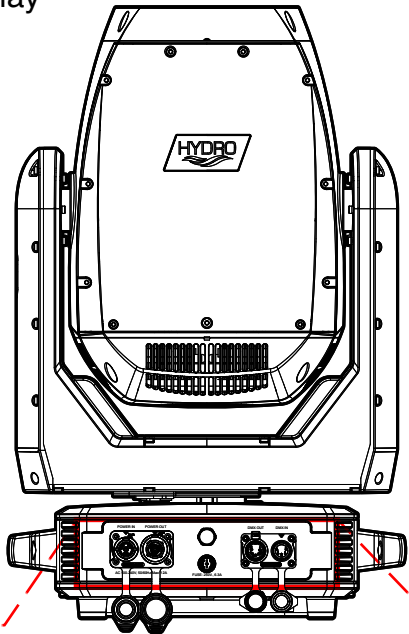

Air Valve

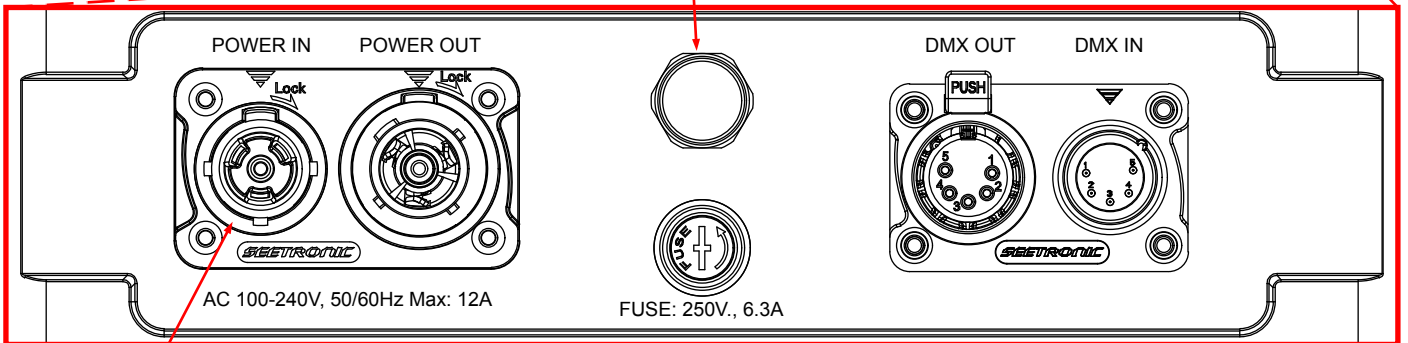

AC 100-240V, 50/60Hz Max: 12A

FUSE: 250V., 6.3A

To maintain the IP65 rating integrity of the fixture, and prevent water from entering the fixture, seal all unused connection rubber caps.

Omega Bracket Installation Point

Safety Cable Anchor Point

NFC Access Point

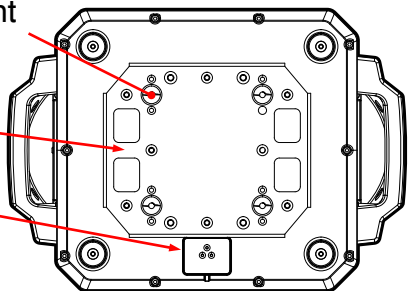

TORQUE SCREWS



PANEL SCREWS MUST BE TIGHTENED WITH A TORQUE WRENCH ACCORDING TO THE TORQUE SPECIFICATION DESCRIBED BELOW.



CAUTION! DO NOT OVER-TORQUE SCREWS AS THIS CAN CAUSE LEAKAGE ISSUES! TO CONFIRM THE IP65 INTEGRITY AFTER ANY PROCEDURE REQUIRING DISASSEMBLY/REASSEMBLY, TEST THE FIXTURE USING ADJ'S IP TESTER. CONTACT ADJ SERVICE FOR MORE DETAILS.



CAUTION! THE USE OF PROTECTIVE GLOVES AND SAFETY GOGGLES IS STRONGLY RECOMMENDED WHILE PERFORMING THE IP PRESSURE TEST!

Recommended Torque Drivers:
UTICA TS-30 (primary)
Proto J6107A or Wiha 28887 (alternates)

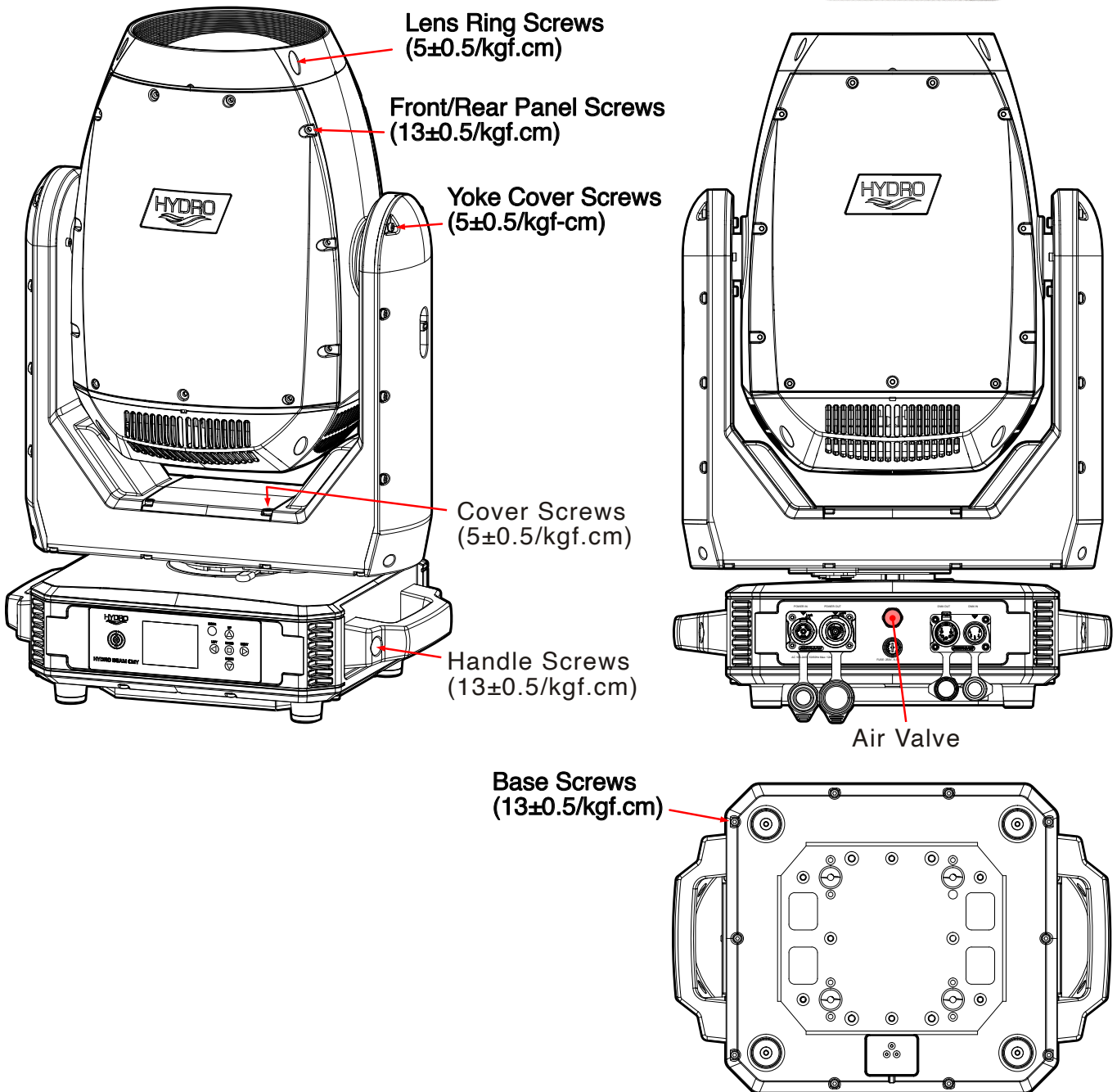

IP TEST PARAMETERS

Following any repair or maintenance procedure that requires disassembly of the fixture, use ADJ's IP Tester to confirm the IP integrity of the fixture. Please contact ADJ Service for information regarding the ADJ IP Tester, or visit the product information page online at: <https://www.adj.com/ip-tester>

CAUTION! THE USE OF PROTECTIVE GLOVES AND SAFETY GOGGLES IS STRONGLY RECOMMENDED WHILE PERFORMING THE IP PRESSURE TEST! AVOID PLACING YOUR FACE, EYES, HANDS, ETC IN PROXIMITY TO THE LENS OF THE FIXTURE WHILE PERFORMING THE TEST!

DE-HUMIDIFICATION: IP65 fixtures operating in high-humidity environments may experience residual fogging or condensation. Such fogging will not affect the fixture, and can be removed using the following procedure: position the unit with the air valve pointing upwards, then open the air valve and run the unit for 1-2 hours after reaching operating temperature. Then, while the fixture is still hot, re-install the air valve and allow the unit to cool down. Please note: this procedure should be performed in a dry, climate-controlled environment. Avoid additional fogging by drying the fixture completely before placing into a road case.

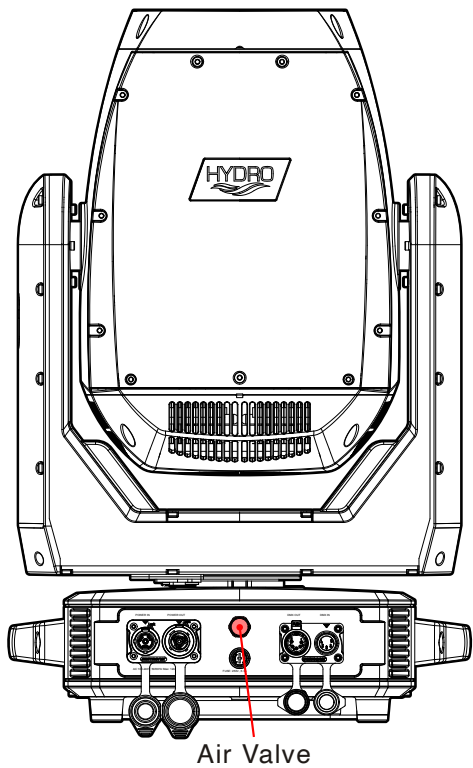

IP PRESSURE TESTING PARAMETERS			
Test Type	Low Pressure Limit	High Pressure Limit	Hold Time
Vacuum Test	-4.35psi (-30.00 KPa)	-5.08 psi (-35.00 KPa)	10s
Pressure Test	3.62 psi (25.00 KPa)	4.35 psi (30.00 KPa)	10s

FIXTURE DISASSEMBLY

The following points should be observed after performing any maintenance procedure that requires disassembly of the unit:

- After the unit has been reassembled, open the valve and allow the unit to run for approximately 2 hours in order to dry out any moisture that has been trapped inside the fixture. The process should continue until indicated humidity drops below 15% for the head and 30% for the base.
- Once this has been achieved, the light can be switched off, but the unit should remain connected to power so that the cooling fan can cool down the unit. Please note that allowing cool down time should **ALWAYS** be done after lamp operation.
- Some units may require partial disassembly in order to gain access to the valve. Please contact ADJ service for information regarding the location and access procedure for the valve on your specific unit model.

COLORS AND GOBOS

COLOR WHEEL



FIXED GOBO WHEEL

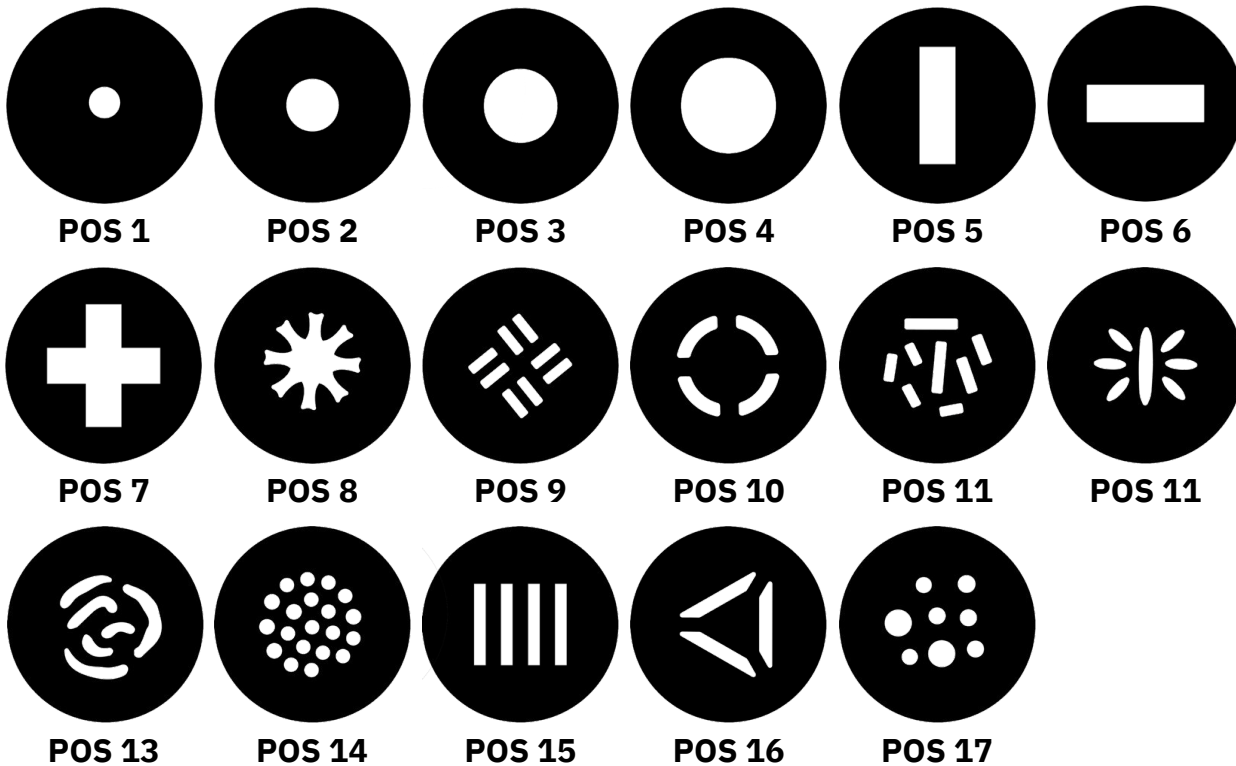

INSTALLATION



DO NOT INSTALL THE FIXTURE IF YOU ARE NOT QUALIFIED TO DO SO!

Fixture **MUST** be installed following all local, national, and country commercial electrical and construction codes and regulations.

When installing the unit, the trussing or area of installation must be able to hold 10 times the weight of the unit and any attached accessories without any deformation. The unit must be secured with a secondary safety attachment, e.g. an appropriately-rated safety cable.

Before rigging/mounting a single fixture to any metal truss/structure or placing the fixture(s) on any surface, a professional equipment installer **MUST** be consulted to determine if the metal truss/structure or surface is properly certified to safely hold the combined weight of the fixture(s), clamps, cables, and accessories.

Safety distance between objects is 1.6' (0.5m)

Minimum distance of flammable materials is 3.3' (1m)

Minimal distances to lighting objects is 1.6' (0.5m)

Ambient operating temperature range is **-20°C to 40°C (-4°F to 104°F)**. Do not operate this device when ambient temperature falls outside of this range.

Fixture(s) should be installed away from walking paths, seating areas, or areas where unauthorized personnel might reach the fixture by hand.

NEVER stand directly below the fixture(s) when rigging, removing, or servicing.

Overhead fixture installation must always be secured with a secondary safety attachment, such as an appropriately rated safety cable that can hold 10 times the weight of the fixture.

Overhead mounting requires extensive experience, including calculating working load limits, knowledge of installation material being used, and periodic safety inspection of all installation material as well as the unit itself. If you lack these qualifications, do not attempt the installation yourself.

The installation should be checked by a skilled person once a year.

OPERATIONAL BREAKS

Duty Cycle - It is strongly recommended to power the fixture down completely when not in use. Doing so will reduce wear on the fixture due to sustained or extended operational periods, thereby maximizing the fixture's operational lifespan.

The light source contained in this luminaire shall only be replaced by the manufacturer or his service agent or a similar qualified person.

The luminaire should be positioned so that prolonged staring into the luminaire at a distance closer than 3.2m is not expected.

TRANSPORTATION AND STORAGE

Pan and tilt locks are for service purposes only and not intended to secure the fixture during transportation; always disengage them before moving or transporting the unit to avoid damage to the internal mechanics.

CONDENSATION AND MOISTURE INSPECTION

Before powering on, remove the fixture from its packaging or road case in a dry, controlled environment and inspect for transport damage or signs of condensation/moisture caused by temperature changes (e.g., cold storage to warm venue). Allow full acclimation to ambient temperature (at least 1–2 hours) until any condensation evaporates completely to prevent electrical damage, short circuits, or corrosion. Do not operate if moisture is present, as this may cause irreversible damage and void the warranty. If issues persist, consult the troubleshooting guide or contact technical support.

INSTALLATION GUIDELINES

CLAMP MOUNTING

This fixture features mounting holes on the underside for the attachment of Omega clamps. When mounting the fixture to a truss or any other suspended structure, be sure to secure an appropriate rated clamp (not included) to each Omega bracket. Insert a bolt of appropriate size through the bottom of the mounting clamp and the central hole on the mounting bracket, and secure them together with a matching nut. Then insert the twist lock fasteners of the Omega bracket into the mounting holes on the fixture, and twist to secure in place. **Please note that two mounting clamps and two Omega brackets are required to securely install this unit.** Additionally, a safety cable of the appropriate weight rating should be secured to at least one of the two available locations on the underside of the fixture base.

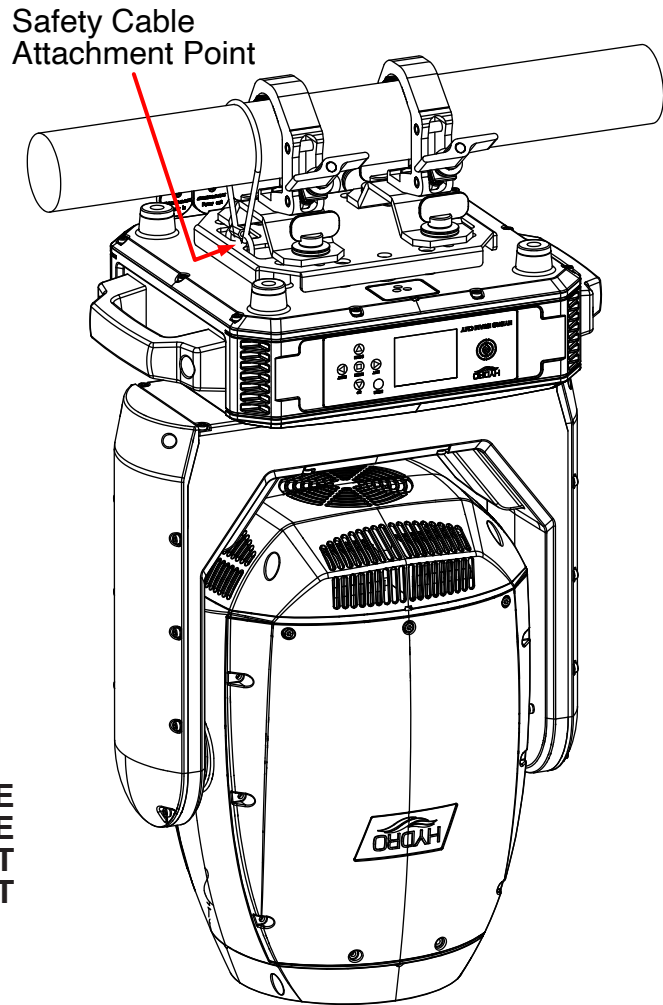
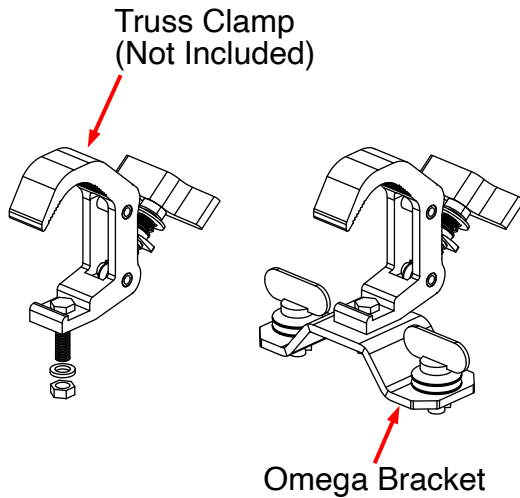

*SAFETY CABLE

**ALWAYS ATTACH A SAFETY CABLE
WHENEVER INSTALLING THIS FIXTURE
IN A SUSPENDED ENVIRONMENT
TO ENSURE THE FIXTURE WILL NOT
DROP IF THE CLAMP FAILS.**

INSTALLATION GUIDELINES

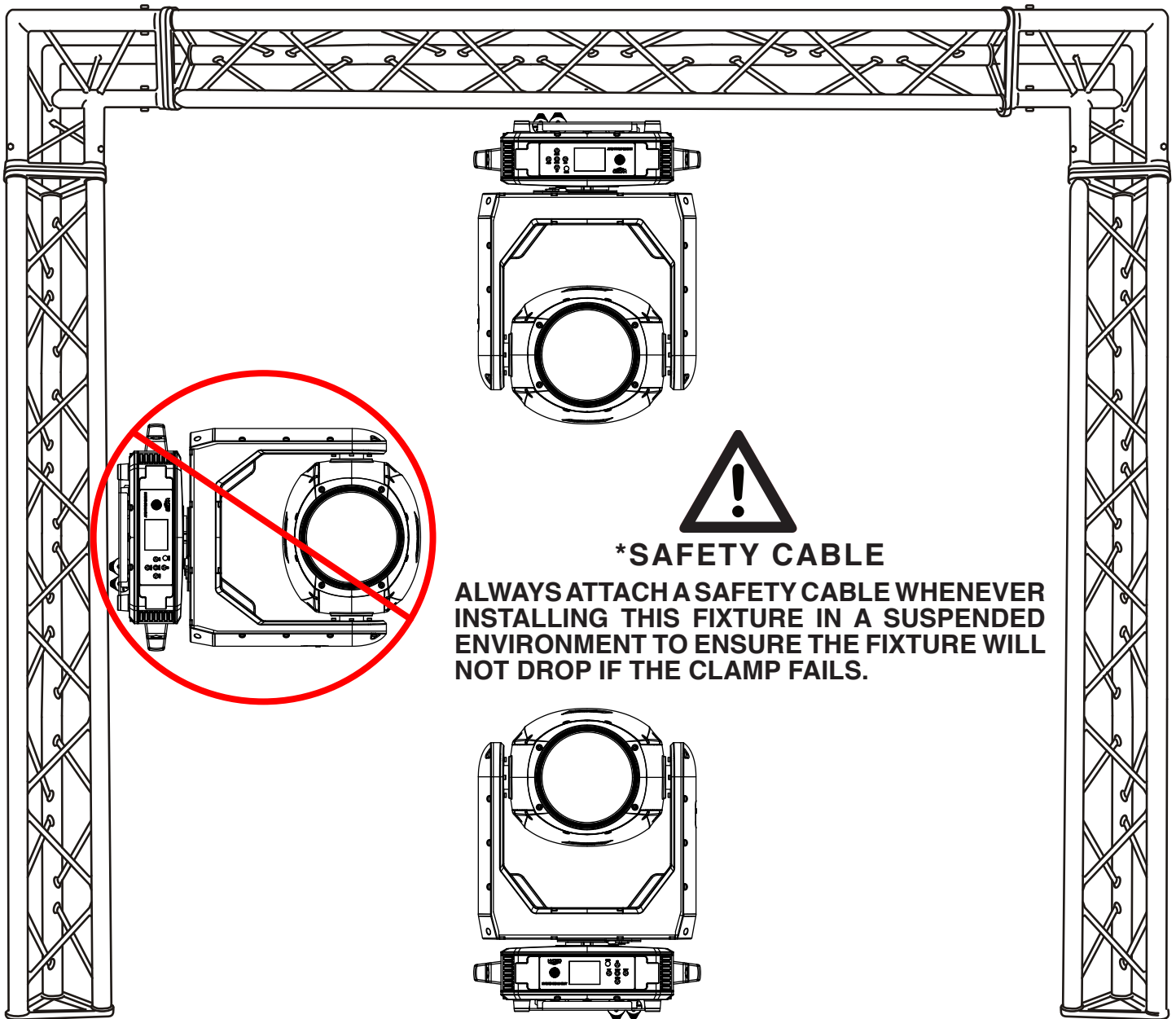

The unit is fully operational in two different mounting positions: hanging upside-down from the ceiling or trussing, or set on a flat level surface. Always use and install a safety cable (not included) as a safety measure to prevent accidental damage and/or injury in the event the clamp fails. Never use the carrying handles for secondary attachment.



FALLING FIXTURES CAN CAUSE SEVERE INJURY OR SERIOUS EQUIPMENT DAMAGE! FOR THIS REASON, FIXTURES SHOULD BE INSTALLED AND INSPECTED ONLY BY QUALIFIED PERSONNEL. DO NOT INSTALL THE UNIT IF YOU LACK THE QUALIFICATIONS TO DO SO, OR IF YOU HAVE DOUBTS ABOUT THE SAFETY AND SECURITY OF THE INSTALLATION SETUP OR LOCATION!



ALWAYS ATTACH A SAFETY CABLE WHENEVER INSTALLING THIS FIXTURE IN A SUSPENDED ENVIRONMENT TO ENSURE THAT THE FIXTURE WILL NOT FALL IF THE CLAMP FAILS.

INSTALLATION GUIDELINES

POTENTIAL INTERNAL FIXTURE DAMAGE FROM EXTERNAL SOURCES OF LIGHT BEAMS

External sources of light beams from direct sunlight, lighting moving head fixtures, and lasers, which are focused directly towards the exterior housing and/or penetrate the front lens opening of ADJ lighting fixtures, can cause severe internal damage including burning to optics, dichroic color filters, glass and metal gobos, prisms, animation wheels, frost filters, iris, shutters, motors, belts, wiring, discharge lamps, and LEDs.

This issue is not specific only to ADJ lighting fixtures, it is a common issue with lighting fixtures from all manufacturers. Although there is no true way to fully prevent this issue from happening, the guidelines below can prevent any potential damage from occurring if followed. Contact ADJ Service for more details.

DO NOT EXPOSE THE FIXTURE AND/OR FRONT LENS OPENING TO LIGHT BEAMS FROM DIRECT SUNLIGHT, OTHER LIGHTING MOVING HEAD FIXTURES, AND LASERS WHILE UNPACKING, INSTALLATION, USE, AND EXTENDED IDLE TIMES OUTDOORS. DO NOT FOCUS A LIGHT BEAM FROM ONE LIGHTING FIXTURE DIRECTLY TOWARDS ANOTHER.

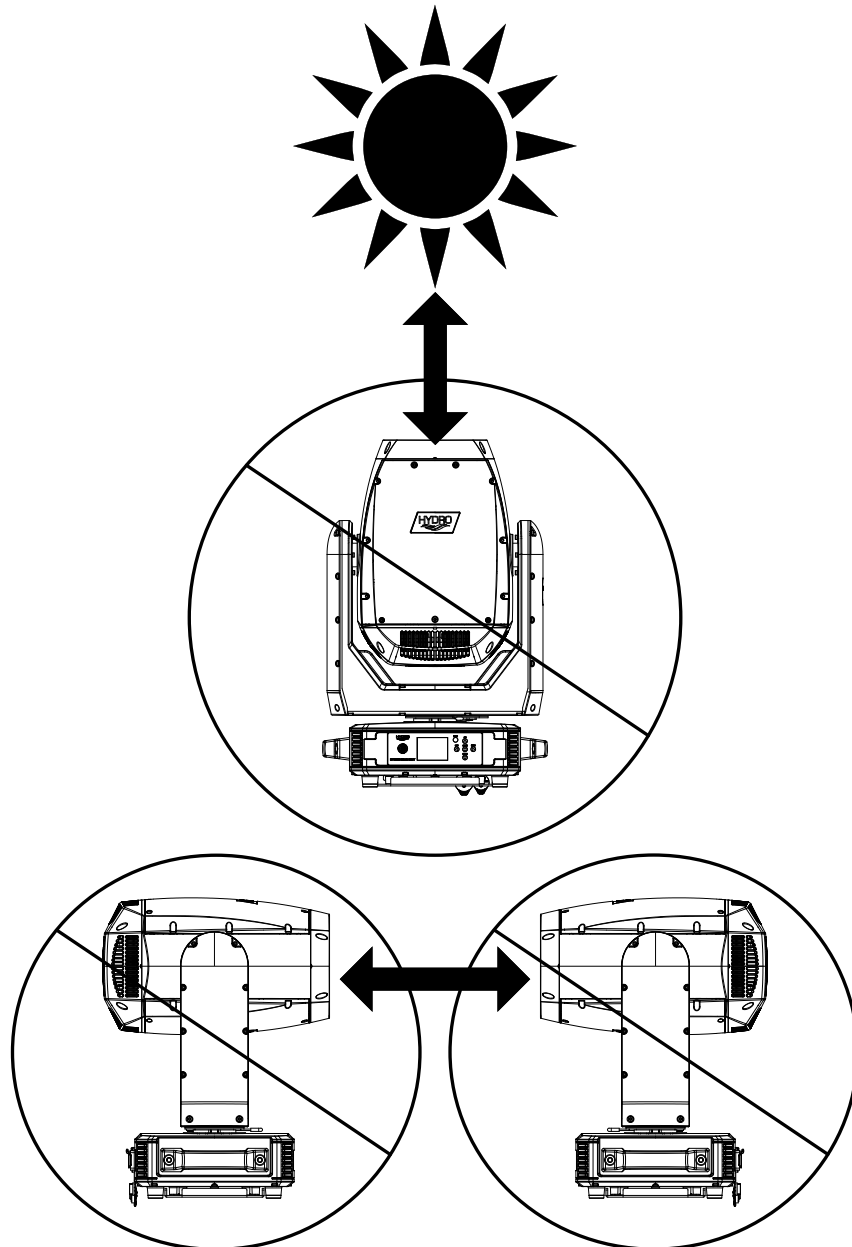

ARIA SETUP AND GUIDELINES

This fixture is equipped with Aria X2. Please note that Aria's wireless functions are switched off by default. Activate Aria X2 and Bluetooth in the system menu to take advantage of the fixture's wireless feature set for wireless connectivity and over the air software updates.

2.4GHZ Versus Sub-Gig (GHz) Frequencies:

Sub-GHz frequencies provide superior reliability and range compared to higher frequencies, making them perfect for consistent communication across vast distances or in difficult conditions. Devices operating in the sub-GHz range, which refers to frequencies below 1 GHz, can transmit signals over significant distances and can penetrate physical barriers such as walls and buildings more effectively. Additionally, these frequencies experience less interference compared to those in the heavily congested 2.4-GHz band, which is commonly used by wireless devices.

In the United States, the 900 MHz band is a versatile frequency range that is utilized by various services, with the FCC overseeing its allocation and regulation.

In the European Union, the 868 MHz frequency is designated by ETSI as the Sub-Gig frequency.

In summary, if an application demands high data rates and more bandwidth in urban or densely populated areas where interference management is feasible, the 2.4 GHz frequency is a suitable choice. On the other hand, for applications requiring long-range communication and better obstacle penetration, particularly in rural or industrial settings with fewer regulatory constraints, a sub-GHz frequency (<1 GHz) is a better option.

Installation Recommendations:

With the many factors that affect and/or interrupt a wireless signal such as walls, glass, metal, objects, and people, it is highly recommended to:

- Install devices a minimum of 9.8 ft. (3m) above audiences and/or ground level where practical.
- Adjust the wireless antenna in a vertical upright position
- Position devices in direct line of sight of the controlling device

Careful planning and testing of the selected installation location is critical to ensure optimum and reliable wireless operation.

**9.8 ft (3m)
Above Ground**

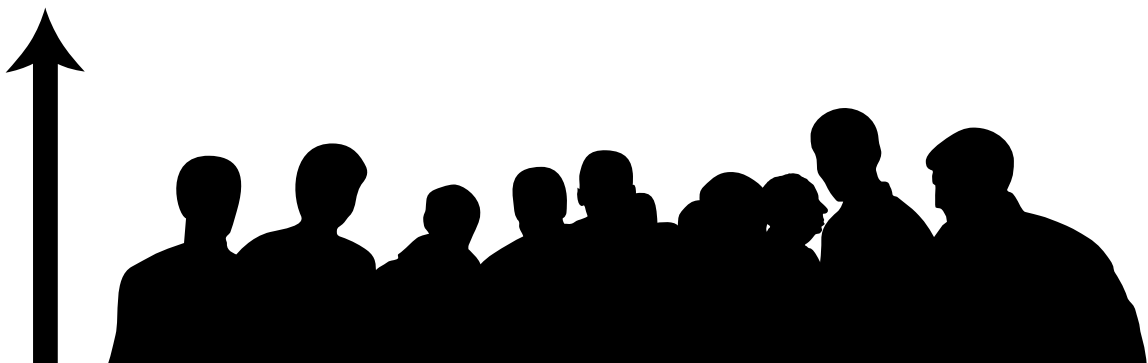

ARIA SETUP AND GUIDELINES

GENERAL INFORMATION

The Aria Bluetooth app has the ability to connect wirelessly to any device that has Aria wireless DMX installed and has Bluetooth enabled.

Before installing the fixture in a remote location, double check that the fixture's main power is switched on, and that the Bluetooth function has been enabled in the fixture's system menu. Certain fixtures may have Bluetooth disabled by default. If this function is disabled, then the fixture cannot be configured remotely using the Aria app, and will have to be configured directly from the fixture's control screen.

Additionally, the user should consider setting the fixture's No DMX setting to "Hold Last". This will allow the fixture to continue running using the current settings, even if the Aria app device moves out of range, the app is closed, or the signal is otherwise interrupted, minimizing disruption in the operation of the fixtures.

LEGACY DEVICES

Please note that legacy connected devices, such as those using Wifly, E-Fly, or Magfly, are not compatible with this app. For such legacy devices, the use of a bridge is recommended, as the bridge can communicate with these devices via its SM220 protocol.

The Aria X2 BLE app is currently available from the Apple app store.

FIXTURE IDENTIFICATION

Aria compatible devices can be identified and connected via the Fixtures tab in the app. This tab displays a field of twenty-four buttons that can be assigned to Aria compatible devices that are within range, and the buttons will automatically be assigned to devices in the order in which they are discovered. If more than twenty-four units are within range, it may be necessary to use the filter feature to search for the desired fixture. Button location can be edited by selecting the configuration key, then the user can drag and drop the buttons to the desired location and hit save to keep changes. Once a device is known to the app, it can also be assigned to a particular button. From that point forward, the assigned device will always be assigned to that button location.

IMPORTANT NOTE: For version 0.65 or higher, a shared system password is required to connect to any device.

Unlike wireless DMX, Bluetooth is a connect first protocol. To connect to a device or fixture, tap the assigned button in the **Fixtures** tab. If the connection is successful, a green frame will appear around the button, indicating that the app was able to retrieve the current channel values from the fixture. The app must be connected to a fixture in order to use its channel controls or view and change settings. Please note that not all Aria devices have channel controls.

Additionally, each fixture can only be connected to one device with the app at any given time. Once a fixture is connected to the app installed on one device, any other devices will be blocked from connecting. As a result, when setting up a new fixture for the first time, best practice is to have only a single user with the app open within range, in order to ensure that the fixture pairs to the intended user's device.

ARIA SETUP AND GUIDELINES

The second table section shows all Aria devices detected in range. A checkmark indicates the device is currently assigned to a button. If more than 24 devices are within range, the user may remove or add devices to the buttons list by tapping a row to check or uncheck a device. If all buttons are full, it will be necessary to uncheck a device before adding another.

Filter: The user can filter which Aria devices get button assignments by tapping “filter” at the top of the view. A popup will appear where the user can enter text to filter devices by username, model name, or manufacturer. **Please note that these searches are case sensitive.**

Note: If a device shows an asterisk (*) it means that there is no fixture profile currently available, and therefore there will be limited support available for that device. The user will still be able to connect and adjust channels if the device supports that feature, but the user will not be able to view how many channels the device has or the channel names.

SECURITY

Each fixture must have a password saved to be secure. When a new fixture is installed for the first time, its password will automatically be set to the app’s system password on first connection. Once the password has been entered, the user will need to exit out to the main page containing the fixture buttons, then de-select and re-select the fixture to lock in the password. From that point forward only, controlling devices that use the correct password can connect to this fixture. **This security is now required by law in most jurisdictions.**

The app will detect any Aria capable fixture within range, even if the app does not have the password to that fixture and therefore cannot access that fixture. If that fixture is selected in the app, the green frame will momentarily appear around that fixture’s button, but then disappear. This indicates that the fixture is visible but inaccessible.

CONNECTIONS

ENSURE ALL CONNECTIONS AND END CAPS ARE PROPERLY SEALED WITH A DIELECTRIC GREASE (AVAILABLE AT MOST ELECTRICAL SUPPLIERS) TO PREVENT WATER CORROSION AND/OR ELECTRICAL SHORT CIRCUIT.

TO MAINTAIN IP65 RATING INTEGRITY AND PREVENT WATER FROM ENTERING THE FIXTURE, ALL UNUSED CONNECTION RUBBER CAPS MUST BE SEALED.

PLEASE NOTE, UNIT IS INTENDED FOR TEMPORARY OUTDOOR USE ONLY!

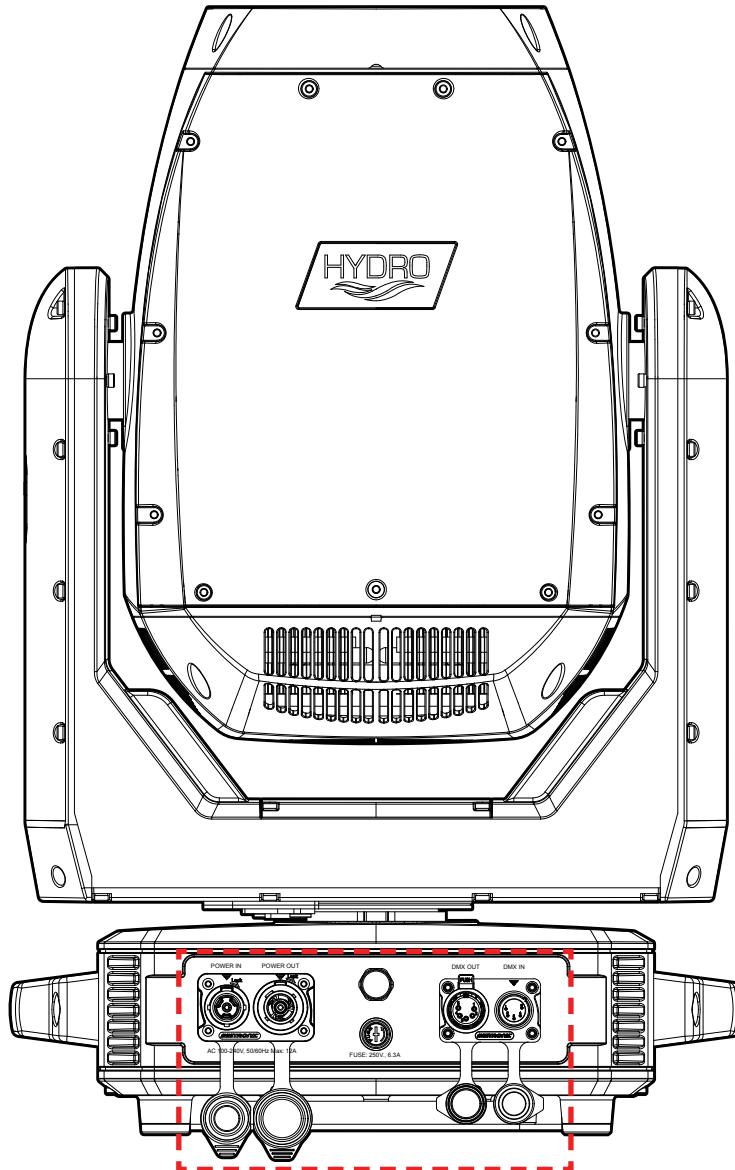

SYSTEM MENU

This unit features a display screen with a 6-button control pad, which can be used to easily adjust any device settings.

Pressing the **MENU** button will cycle through the various Main Menu options. When the desired Main Menu option is displayed on the screen, press the **ENTER** button to enter the sub-menu, then use the **UP**, **DOWN**, **LEFT**, and **RIGHT** buttons to navigate through sub-menu options. In some cases, there will be a second sub-menu that can be navigated in the same way.

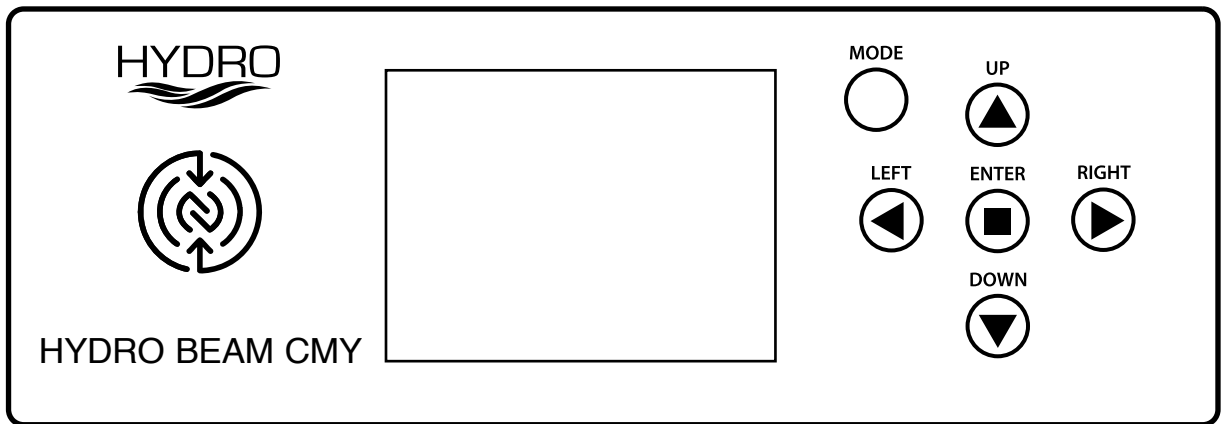

This fixture can be updated via the service port. Please contact ADJ Support for further details.



ADJ SERVICE USA - Monday - Friday 8:00am to 4:30pm PST
323-582-2650 | Fax: 323-832-2941 | support@adj.com

ADJ SERVICE EUROPE - Monday - Friday 08:30 to 17:00 CET
+31 45 546 85 60 | Fax: +31 45 546 85 96 | support@adj.eu

SYSTEM MENU

MAIN MENU	OPTIONS / VALUES (Default Settings in BOLD)		
DMX Settings	DMX Address	001 - 512	
	DMX Mode	20ch, 24ch	
	No DMX Status	Hold Last , Blackout, Manual	
Personality	Prim/Sec Mode	Primary, Secondary	
	Signal	DMX or Aria	
		Aria In / DMX Out	
		DMX In / Aria Out	
	Aria Settings	Aria Enable	ON / OFF
		Frequency	2.4 GHz
			Sub Gig US
			Sub Gig EU
		2.4Ghz CH	00 ~15
		Sub Gig CH	00 ~09
		Mesh	ON / OFF
		Bluetooth	ON / OFF
		Security (Requires Password if assigned)	Pin Enable / Disable
	Set or Edit Password		
	Clear Password		
	Status Settings	Pan Degree	630 / 540
		Pan Invert	ON / OFF
		Tilt Invert	ON / OFF
		P./T. Feedback	ON / OFF
		P./T. Speed	Fast , Slow
		RDM	ON / OFF
		Hibernation	OFF, 01M~99M, 15M
	Reset Motors	Reset All Motors	YES / NO
		Pan/Tilt Reset	YES / NO
		Color Reset	YES / NO
		Gobo Reset	YES / NO
		Frost Reset	YES / NO
		Prism Reset	YES / NO
	Display	Intensity	1- 10
		Display invert	Auto / YES / NO
		Screen Saver Delay	OFF , 01 - 10 minutes
		Key Lock	OFF/ON/ON1
	Service (Passcode = 050)	Effect Adjust (Calibration)	Pan -127-127
Tilt -127-127			
Color -127-127			
...			
Focus -127-127			
Color Adjust		Color1 -127-127	
		Color2 -127-127	
		...	
		Color15 -127-127	
		Factory Restore	YES / NO

SYSTEM MENU

MAIN MENU	OPTIONS / VALUES (Default Settings in BOLD)			
ManualControl	Pan	000-255		
	Pan Fine	000-255		
	Tilt	000-255		
	Tilt Fine	000-255		
	Cyan	000-255		
	Magenta	000-255		
	Yellow	000-255		
	Color	000-255		
	Color Macro	000-255		
	Multicolor Effect	000-255		
	Gobo	000-255		
	Prism1	000-255		
	Prism1 Rot	000-255		
		...		
	P./T.Speed	000-255		
Special	000-255			
Lamp Control	Lamp ON / OFF	ON / OFF		
	Lamp ON with Power	ON / OFF		
	Lamp ON via DMX	ON / OFF		
	Lamp OFF via DMX	ON / OFF		
	Lamp Mode	Standard ECO		
Information	Fixture Life Time	Power On Time	xxxxxx Hours	
		P-On Time-R	xxxxxx Hours	
		P-On Time Reset	Passcode	
	Total Lamp Time	Lamp On Time	xxxxxx Hours	
		Lamp On Time-R	xxxxxx Times	
		Lamp On Time Reset	Passcode	
	Fixture Temperatures	Head	Current	xxx F / xxx C
			Max Resettable	xxx F / xxx C
			Max Not Resettable	xxx F / xxx C
		Base	Current	xxx F / xxx C
			Max Resettable	xxx F / xxx C
			Max Not Resettable	xxx F / xxx C
		Ballast	Current	xxx F / xxx C
			Max Resettable	xxx F / xxx C
			Max Not Resettable	xxx F / xxx C
		Reset Head Temp	Passcode	
		Reset Base Temp	Passcode	
		Reset Ballast Temp	Passcode	
	Fixture Humidity	Head	XX%	
		Base	XX%	
	Fan Info.(RPM)	Base Fan	xxxx	
		Ballast Fan	xxxx	
		Head Fan 1	xxxx	
		Head Fan 2	xxxx	
		Head Fan 3	xxxx	
		Head Fan 4	xxxx	
	DMX Values	Pan		
Tilt				
		...		
Error Logs	Fixture Errors	List Errors one by one		
	Reset Error Log	Passcode		
Software Version	x.xx			
RDM ID	xxxxxxxxxxxx			
Aria ID	xx:xx:xx:xx:xx:xx			

DIMMER CURVES

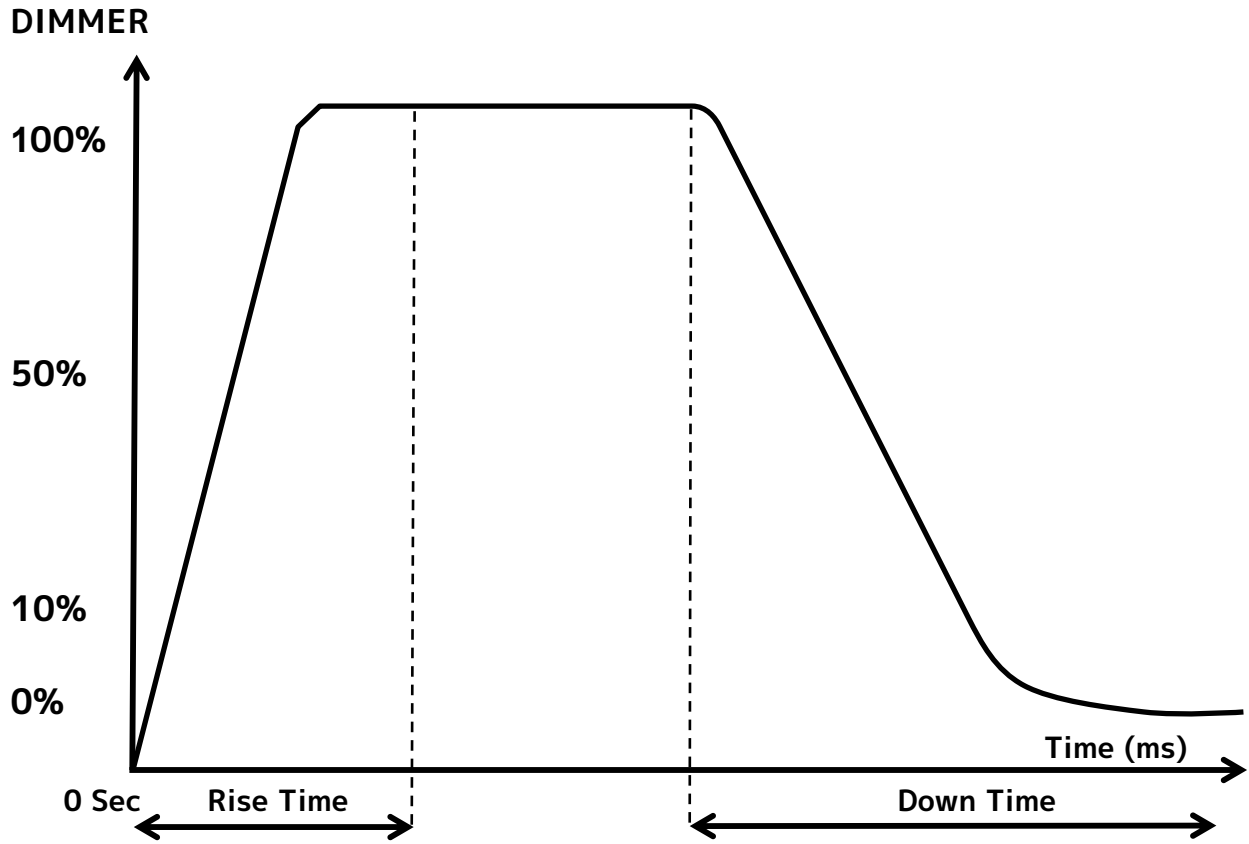

Dimming Curve Ramp Effect	0 sec Fade Time		1 sec Fade Time	
	Rise Time (ms)	Down Time (ms)	Rise Time (ms)	Down Time (ms)
Standard (default)	0	0	0	0
Stage	780	1100	1540	1660
TV	1180	1520	1860	1940
Architectural	1380	1730	2040	2120
Theatre	1580	1940	2230	2280
Stage 2	0	1100	0	1660

DIMMER MODES

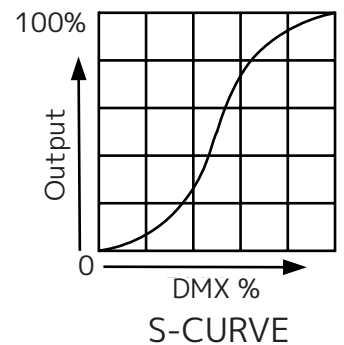
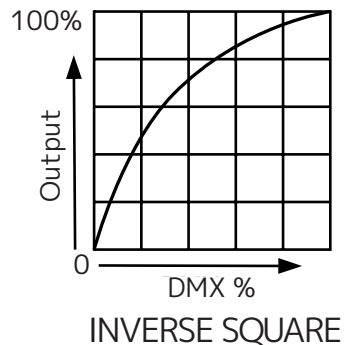
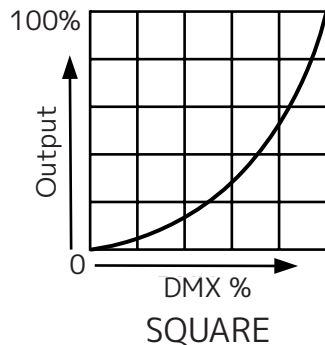
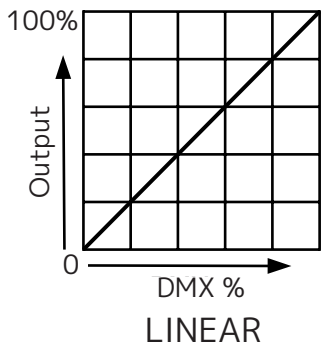

DMX SETUP

DMX-512: DMX is short for Digital Multiplex. This is a universal protocol used as a form of communication between intelligent fixtures and controllers. A DMX controller sends DMX data instructions from the controller to the fixture. DMX data is sent as serial data that travels from fixture to fixture via the DATA “IN” and DATA “OUT” XLR terminals located on all DMX fixtures (most controllers only have a DATA “OUT” terminal).

DMX Linking: DMX is a language allowing all makes and models of different manufactures to be linked together and operate from a single controller, as long as all fixtures and the controller are DMX compliant. To ensure proper DMX data transmission, when using several DMX fixtures try to use the shortest cable path possible. The order in which fixtures are connected in a DMX line does not influence the DMX addressing. For example; a fixture assigned a DMX address of 1 may be placed anywhere in a DMX line, at the beginning, at the end, or anywhere in the middle. When a fixture is assigned a DMX address of 1, the DMX controller knows to send DATA assigned to address 1 to that unit, no matter where it is located in the DMX chain.

Data Cable (DMX Cable) Requirements (For DMX Operation): The Hydro Beam CMY can be controlled via DMX-512 protocol. Your unit and your DMX controller requires a 5-pin XLR connector for data input/output. We recommend Accu-Cable DMX cables. If you are making your own cables, be sure to use standard 110-120 Ohm shielded cable (This cable may be purchased at almost all pro lighting stores). Your cables should be made with a male and female XLR connector on either end of the cable. Also remember that DMX cable must be daisy chained and cannot be split.

XLR Male Socket

XLR Female Socket

R = 1/4W 120ohm

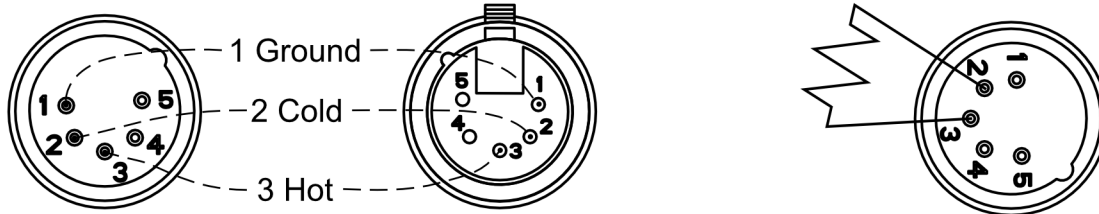

Special Note: Line Termination. When longer runs of cable are used, you may need to use a terminator on the last unit to avoid erratic behavior. A terminator is a 110-120 ohm 1/4 watt resistor which is connected between pins 2 and 3 of a male XLR connector (DATA + and DATA -). This unit is inserted in the female XLR connector of the last unit in your daisy chain to terminate the line. Using a cable terminator (ADJ part number Z-DMX/T) will decrease the possibilities of erratic behavior.

TO MAINTAIN IP65 RATING INTEGRITY AND PREVENT WATER FROM ENTERING THE FIXTURE, ALL UNUSED CONNECTION RUBBER CAPS MUST BE SEALED AND ONLY IP65 RATED POWER AND DATA CABLES MUST BE USED.

DMX SETUP

All fixtures should be given a DMX starting address when using a DMX controller, so the correct fixture responds to the correct control signal. This digital starting address is the channel number from which the fixture starts to “listen” to the digital control signal sent out from the DMX controller. The assignment of this starting DMX address is achieved by setting the correct DMX address on the digital control display on the fixture.

You can set the same starting address for all fixtures or a group of fixtures, or set different addresses for each individual fixture. Setting all fixtures to the same DMX address will cause all fixtures to react in the same way, in other words, changing the settings of one channel will affect all the fixtures simultaneously.

If you set each fixture to a different DMX address, each unit will start to “listen” to the channel number you have set, based on the quantity of DMX channels of each fixture. That means changing the settings of one channel will only affect the selected fixture. In the case of this fixture, when in 20 Channel mode, you should set the starting DMX address of the first unit to 1, the second unit to 21 (20 + 1), the third unit to 41 (21 + 20), and so on. (See the chart below for more details).

Channel Mode	Unit 1 Address	Unit 2 Address	Unit 3 Address	Unit 4 Address
20 Channels	1	21	41	61
24 Channels	1	25	49	73

DMX TRAITS:

CHANNEL		DMX VALUES	FUNCTION	
20Ch	24Ch			
1	1	000-255	Pan	
	2	000-255	Pan Fine	
	2	3	000-255	Tilt
		4	000-255	Tilt Fine
	3	5	000-255	Cyan, 0% ~ 100%
4	6	000-255	Magenta, 0% ~ 100%	
5	7	000-255	Yellow, 0% ~ 100%	
6	8		Color	
		000-003	White	
		004-007	Red	
		008-011	Blue	
		012-015	Green	
		016-019	Lime	
		020-023	Orange	
		024-027	Pink	
		028-031	Lavendar	
		032-035	Medium Red	
		036-039	Aqua	
		040-043	Amber	
		044-047	CTB 9000k	
		048-051	4500K	
		052-055	CTO 3200k	
		056-059	UV	
		060-061	White	
		062-063	White to Red	
		064-065	Red	
		066-067	Red to Blue	
		068-069	Blue	
		070-071	Blue to Green	
		072-073	Green	
		074-075	Green to Lime	
		076-077	Lime	
		078-079	Lime to Orange	
		080-081	Orange	
		082-083	Orange to Pink	
		084-085	Pink	
		086-087	Pink to Lavender	
		088-089	Lavender	
		090-091	Lavender to Medium Red	
		092-093	Medium Red	
		094-095	Medium Red to Aqua	
		096-097	Aqua	
		098-099	Aqua to Amber	
		100-101	Amber	
		102-103	Amber to CTB 9000k	
		104-106	CTB 9000k	
		107-109	CTB 9000k to 4500k	
		110-112	4500k	
113-115	4500k to CTO 3200k			
116-118	CTO 3200k			
119-121	CTO 3200k to UV			
122-124	UV			
125-127	UV to White			
128-189	Clockwise Rotation Fast to Slow			
190-193	Stop			
194-255	Counter-Clockwise Rotation Slow to Fast			

DMX TRAITS:

CHANNEL		DMX VALUES	FUNCTION
20Ch	24Ch		
7	9		Color Macros - CMY and Color Wheel
		000-031	OFF
		032-039	Macro1
		040-047	Macro2
		048-055	Macro3
		056-063	Macro4
		064-071	Macro5
		072-079	Macro6
		080-087	Macro7
		088-095	Macro8
		096-103	Macro9
		104-111	Macro10
		112-119	Macro11
		120-127	Macro12
		128-135	Macro13
		136-143	Macro14
		144-151	Macro15
		152-159	Macro16
		160-167	Macro17
		168-175	Macro18
		176-183	Macro19
		184-191	Macro20
		192-199	Macro21
		200-207	Macro22
		208-215	Macro23
		216-223	Macro24
		224-231	Macro25
		232-239	Macro26
240-247	Macro27		
248-255	Random CMY		
8	10		Multicolor Effect
		000-007	Close
		008-255	Open
9	11		Static Gobo
		000-002	Open
		003-005	Gobo1
		006-008	Gobo2
		009-011	Gobo3
		012-014	Gobo4
		015-017	Gobo5
		018-020	Gobo6
		021-023	Gobo7
		024-026	Gobo8
		027-029	Gobo9
		030-032	Gobo10
		033-035	Gobo11
		036-038	Gobo12
		039-041	Gobo13
		042-044	Gobo14
		045-047	Gobo15
048-050	Gobo16		
051-055	Gobo 17		

DMX TRAITS:

CHANNEL		DMX VALUES	FUNCTION
20Ch	24Ch		
9	11		Static Gobo
		056-059	Open Shaking Slow to Fast
		060-063	Gobo1 Shaking Slow to Fast
		064-067	Gobo2 Shaking Slow to Fast
		068-071	Gobo3 Shaking Slow to Fast
		072-075	Gobo4 Shaking Slow to Fast
		076-079	Gobo5 Shaking Slow to Fast
		080-083	Gobo6 Shaking Slow to Fast
		084-087	Gobo7 Shaking Slow to Fast
		088-091	Gobo8 Shaking Slow to Fast
		092-095	Gobo9 Shaking Slow to Fast
		096-099	Gobo10 Shaking Slow to Fast
		100-103	Gobo11 Shaking Slow to Fast
		104-107	Gobo12 Shaking Slow to Fast
		108-111	Gobo13 Shaking Slow to Fast
		112-115	Gobo14 Shaking Slow to Fast
		116-119	Gobo15 Shaking Slow to Fast
120-123	Gobo16 Shaking Slow to Fast		
124-127	Gobo17 Shaking Slow to Fast		
128-189	Clockwise Rotation Fast to Slow		
190-193	Stop		
194-255	Counter-Clockwise Rotation Slow to Fast		
10	12		Prism1
		000-007	Close
		008-255	Open
11	13		Prism1 Rotation
		000-127	0% ~ 100%
		128-189	Clockwise Rotation Fast to Slow
		190-193	Stop
194-255	Counter-Clockwise Rotation Slow to Fast		
12	14		Prism2
		000-007	Close
		008-255	Open
13	15		Prism2 Rotation
		000-127	0% ~ 100%
		128-189	Clockwise Rotation Fast to Slow
		190-193	Stop
194-255	Counter-Clockwise Rotation Slow to Fast		
14	16		Shutter
		000-031	Close
		032-063	Open
		064-095	Strobe from Slow to Fast
		096-127	Open
		128-159	Pulse Effect in sequence
		160-191	Open
		192-223	Random Strobe Slow to Fast
224-255	Open		
15	17	000-255	Dimmer , 0% ~ 100%
	18	000-255	Dimmer Fine , 0% ~ 100%
16	19	000-255	Focus , 0% ~ 100%
	20	000-255	Focus Fine , 0 ~ 100%
17	21		Frost
		000-010	Off
		011-255	On
18	22	000-255	CMY Speed , Fast to Slow
19	23	000-255	Pan/Tilt Speed , Fast to Slow

DMX TRAITS:

CHANNEL		DMX VALUES	FUNCTION
20Ch	24Ch		
20	24		Special
		000-019	Null
		020-029	Enable color wheel indexing
		030-039	Disable color wheel indexing
		040-059	Enable frost indexing
		060-069	Disable frost indexing
		070-079	Enable blackout while Pan/Tilt moving
		080-089	Disable blackout while Pan/Tilt moving
		090-099	Enable blackout while color changing
		100-109	Disable blackout while color changing
		110-119	Enable blackout while gobo changing
		120-129	Disable blackout while gobo changing
		130-139	Lamp On
		140-149	Reset XY
		150-159	Reset Effect
		160-169	Reset Color (Color Wheel and CMY)
		170-199	No Function
		200-209	Reset All
		210-229	No Function
		230-239	Lamp Off
240-255	No Function		

PRIMARY-SECONDARY SETUP

This function allows you to link units together to run in a Primary-Secondary set-up, in which one unit will act as the controlling unit and the others will react to the controlling unit's built-in programs. Any unit can be configured to act as a Primary or as a Secondary, but only one unit in a given system can be programmed to act as the Primary.

Primary-Secondary Connections and Settings:

1. Daisy chain your units via the XLR connectors on the rear panels of each unit. Use standard XLR data cables to link your units together. Remember that the male XLR connector is the input and the female XLR connector is the output. The first unit in the chain (primary) will use the female XLR connector only. The last unit in the chain will use the male XLR connector only.
2. Use the display screen and control panel to navigate to Personality > Prim/Sec Mode. Select this sub-menu using the ENTER button, and use the UP and DOWN buttons to toggle between "Primary" and "Secondary". Press ENTER to confirm your selection.
3. Repeat Step 2 for each unit in the system. Make sure that only one unit is designated as the Primary, while all other units are designated as Secondaries.
4. The secondary units will now follow the behavior of the primary unit.

NOTES:

- Only one unit should be configured as the primary, while all the other units should be configured as secondaries.
- All units should be set to the same DMX channel mode.
- If fixtures fail to sync, verify that all settings mentioned above are the same, then power all devices off, then switch them on again to re-establish the link.

MULTI-UNIT POWER-LINKING

With this feature you can connect the fixtures to one another using the power cable input and output sockets.

NOTE: USE CAUTION WHEN POWER LINKING OTHER FIXTURES AS THE POWER CONSUMPTION OF OTHER MODEL FIXTURES MAY EXCEED THE MAX POWER OUTPUT ON THIS FIXTURE! CHECK SILK SCREEN FOR MAX AMPS.

REMOTE DEVICE MANAGEMENT (RDM)

NOTE: In order for RDM to work properly, RDM enabled equipment must be used throughout the entire system, including DMX data splitters and wireless systems.

Remote Device Management (RDM) is a protocol that sits on top of the DMX512 data standard for lighting, allowing the DMX systems of the fixtures to be modified and monitored remotely. This protocol is ideal for instances in which a unit is installed in a location that is not easily accessible.

With RDM, the DMX512 system becomes bi-directional, allowing a compatible RDM enabled controller to send out a signal to devices on the wire, as well as allowing the fixture to respond (known as a GET command). The controller can then use its SET command to modify settings that would typically have to be changed or viewed directly via the unit's display screen, including the DMX Address, DMX Channel Mode, and Temperature Sensors.

FIXTURE RDM INFORMATION:

RDM Code	Device ID	Device Model ID	Personality ID
0x1900	Generate by MCU ID	0x0007	20ch(1) 24ch(2)

* The system randomly allocates 32-bit data based on the microcontroller's 32-bit unique identifier (UID).

Please be aware that not all RDM devices support all RDM features, and therefore it is important to check beforehand to ensure that the equipment that you are considering includes all of the features that you require.

0x0001 DISC_UNIQUE_BRANCH	0x0081 MANUFACT_LABEL
0x0002 DISC_MUTE	0x0082 DEVICE_LABEL
0x0003 DISC_UN_MUTE	0x00E0 DMX_PERSONALITY
0x0050 SUPPORTED_PARAMETERS	0x00E1 DMX_PERSONALITY_DESCRIPTION
0x0051 PARAMETER_DESCRIPTION	0x0400 DEVICE_HOURS
0x0060 DEVICE_INFO	0x0401 LAMP_HOURS
0x00C0 SOFTWARE_VERSION_LABEL	0x0402 LAMP_STRIKES
0x00F0 DMX_START_ADDRESS	0x0600 PAN_INVERT
0x1000 IDENTIFY_DEVICE	0x0601 TILT_INVERT
0x0080 DEVICE_MODEL_DESCRIPTION	0x0602 PAN_TILT_SWAP

MAINTENANCE GUIDELINES

DISCONNECT POWER BEFORE PERFORMING ANY MAINTENANCE!

CLEANING

Frequent cleaning is recommended to ensure proper function, optimized light output, and an extended life. The frequency of cleaning depends on the environment in which the fixture operates: damp, smoky, or particularly dirty environments can cause greater accumulation of dirt on the fixture's optics. Clean the external lens surface regularly with a soft cloth to avoid dirt/debris accumulation.

NEVER use alcohol, solvents, or ammonia-based cleaners.

MAINTENANCE

Regular inspections are recommended to ensure proper function and extended life. There are no user serviceable parts inside this fixture. Please refer all other service issues to an authorized ADJ service technician. Should you need any spare parts, please order genuine parts from your local ADJ dealer.

Please refer to the following points during routine inspections:

- A. A detailed electrical check by an approved electrical engineer every three months, to make sure the circuit contacts are in good condition and prevent overheating.
- B. Be sure all screws and fasteners are securely tightened at all times. Loose screws may fall out during normal operation, resulting in damage or injury as larger parts could fall.
- C. Check for any deformations on the housing, color lenses, rigging hardware, and rigging points (ceiling, suspension, trussing). Deformations in the housing could allow for dust to enter into the fixture. Damaged rigging points or unsecured rigging could cause the fixture to fall and seriously injure a person(s).
- D. Electric power supply cables must not show any damage, material fatigue, or sediments.

NEVER remove the ground prong from the power cable.

ERROR CODES

Error Codes subject to change without notice	
ERROR CODE	ERROR GROUP
Pan Encoder Error	Encoder Error
Tilt Encoder Error	
Pan Sensor Error	Sensor Error
Tilt Sensor Error	
Cyan Sensor Error	
Magenta Sensor Error	
Yellow Sensor Error	
Color Sensor Error	
Gobo Sensor Error	
Prism 1 Sensor Error	
Prism 2 Sensor Error	
Prism 2 Rot Sensor Error	
Focus Sensor Error	
CPU-B Error	Communication Error
CPU-C Error	
CPU-D Error	
CPU-E Error	
Base Fan Error	Fan Error
Power Fan Error	
Head Fan1 Error	
Head Fan2 Error	
Head Fan3 Error	
Head Fan4 Error	
EEPROM Error	EEPROM Error
Lamp Comm Error	Lamp Error
Lamp Over Temp	
Lamp Ignite Error	

SPECIFICATIONS

Light Source:

- OSRAM Sirius HRI 310W PRO Discharge Lamp (6,000 hr.)
- Color temperature: 7850K (+/- 500K)
- CRI: 86 (+/- 5)

Features:

- CMY Color Mixing
- On-Board Wireless DMX
- Motorized Focus + 16-bit fine focus
- 2-degree beam angle
- Frost Filter to create wash effect
- High quality glass lens
- 2 Rotating prisms
- 0-100% smooth dimming
- Pan/Tilt locks
- Various strobe speeds
- OTA, wireless, firmware updates
- Fan cooled

Color Wheel:

- 14 dichroic colors + white (Includes CTO (3200K), CTB (9000k) & UV)
- Indexable color wheel for split colors
- Separate Multi-Color Effect

GOBO Wheel:

- 17 static GOBOs + open (4 GOBOs are beam reducers)
- GOBO Shake Effect

Prism Wheels:

- 2 Rotating prisms
- 16 facet circular and 6 facet linear prisms
- Prisms Overlay

Control:

- Protocols: DMX512, RDM, Aria X2, NFC
- Control Mode: DMX512 & Manual (On-board Controls)
- 2 DMX Channel Modes: 20/24 Channels
- Color LCD display with 6-button function menu
- 0-100% smooth dimming
- Various strobe speeds
- With Wired Digital Communication Network

Pan/Tilt:

- Pan: 540 degrees (plus 16-bit fine pan)
- Tilt: 270 degrees (plus 16-bit fine tilt)
- 3-phase, High Speed, Pan/Tilt motors

Connections:

- DMX Connections: Seetronic IP65 Rated, 5-pin DMX In/Out (Data link max: 32 fixtures)
- Power Connections: IP65 locking power In/Out connections to daisy chain power

Electrical:

- Multi-voltage operation: 100-240V, 50/60Hz
- Max power consumption: 450W (@120V), 430W (@230V)
- Fuse Protected: 6.5A

Dimensions & Weight:

- Dimensions: 15.5" (L) x 11.4" (W) x 23.2" (H) / 394 x 290 x 589mm
- Weight: 56 lbs. / 25.6 kg.

Approvals / Ratings

- CE, cETLus (Pending), FCC, IP65



What's Included:

- 2x Omega Brackets (107 Type)
- 2M, outdoor locking 14AWG power cord

Accessories (Sold Separately):

- Quick Rig Clamp
- Quick Rig Clamp BLK
- Pro-Clamp
- Accu-Cable Tour Link 5P15 - 15ft. 5-pin male/female professional grade DMX Cable
- SIP152 - 16ft., IP65-Rated male to female locking power cord
- (2) Hydro Beam CMY fixtures fit in the ADJ DRC MHX Road Case

DIMENSIONS

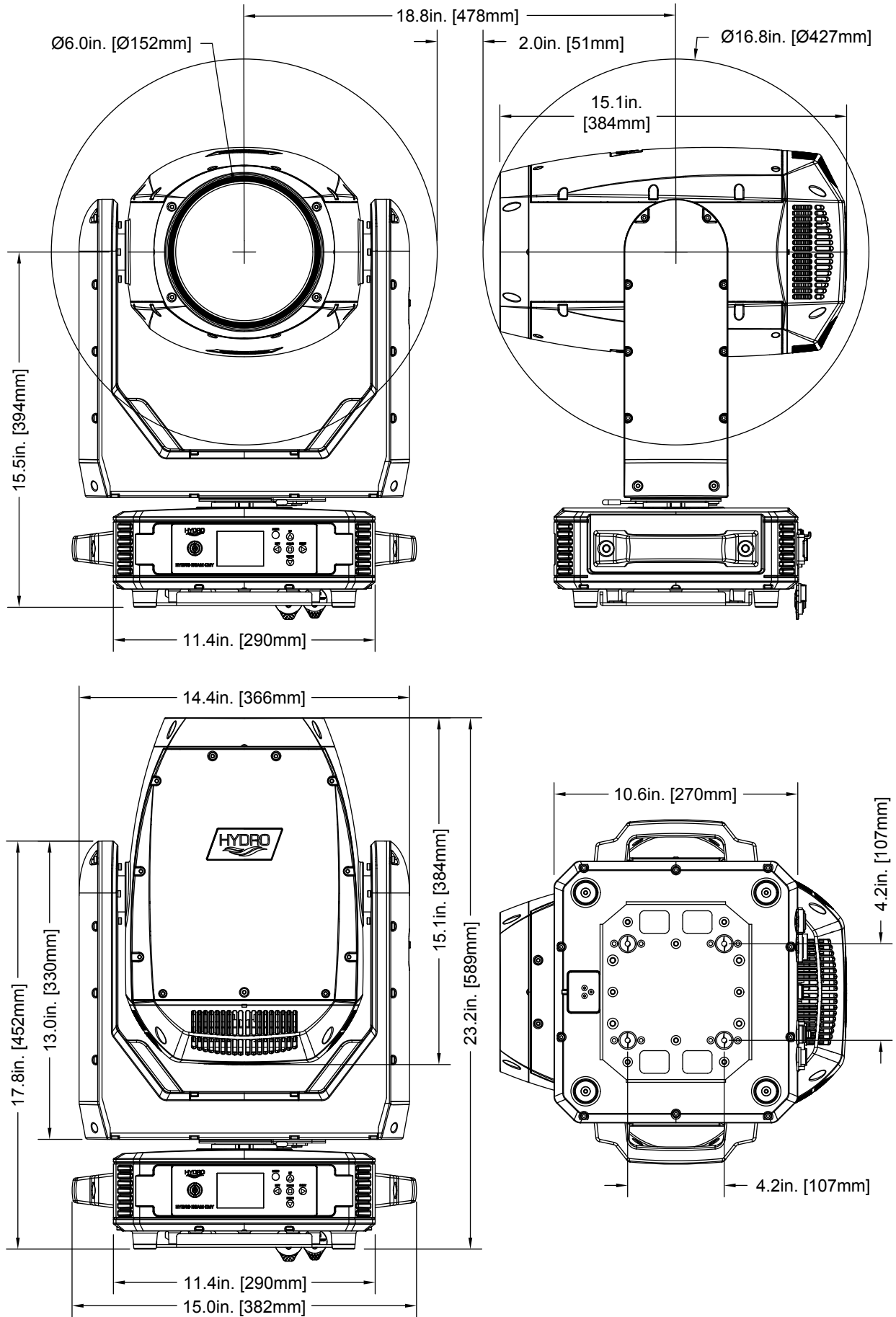

FCC STATEMENT

This device complies with Part 15 of the FCC Rules. Operation is subject to the following two conditions: (1) this device may not cause harmful interference, and (2) this device must accept any interference received, including interference that may cause undesired operation.

FCC RADIO FREQUENCY INTERFERENCE WARNINGS & INSTRUCTIONS

This product has been tested and found to comply with the limits as per Part 15 of the FCC Rules. These limits are designed to provide reasonable protection against harmful interference in a residential installation. This device uses and can radiate radio frequency energy and, if not installed and used in accordance with the included instructions, may cause harmful interference to radio communications. However, there is no guarantee that interference will not occur in a particular installation. If this device does cause harmful interference to radio or television reception, which can be determined by turning the device off and on, the user is encouraged to try to correct the interference by one or more of the following methods:

- Reorient or relocate the device.
- Increase the separation between the device and the receiver.
- Connect the device to an electrical outlet on a circuit different from which the radio receiver is connected.
- Consult the dealer or an experienced radio/TV technician for help.

Europe Energy Saving Notice

Energy Saving Matters (EuP 2009/125/EC)

Saving electric energy is a key to help protecting the environment. Please turn off all electrical products when they are not in use. To avoid power consumption in idle mode, disconnect all electrical equipment from power when not in use. Thank you



INDEX

- Air valve, 9, 11
- Ambient operating temperature, 7, 13
- Aria X2, 17–19, 22, 35

- Bluetooth, 17–19, 22

- CMY color mixing, 5, 22, 27, 35
- Color macros, 23, 28
- Color wheel, 12, 27, 35
- Condensation, 7, 11, 13
- Control modes, 22, 35

- Dielectric grease, 6, 7, 20
- Dimmer, 24, 29, 35
- Dimmer curves, 24
- DMX address, 22, 26, 32
- DMX channel modes, 22, 26, 32, 35
- DMX setup, 25–26
- DMX traits, 27–30

- Error codes, 34

- FCC statement, 37
- Fixture humidity, 23
- Fixture temperatures, 23
- Focus, 5, 6, 23, 29, 34, 35
- Frost filter, 5, 22, 29, 35

- Gobo shake, 5, 29, 35
- Gobo wheel, 12, 28–29, 35

- Hibernation, 22

- IP65 rating, 5–6, 10–11, 20, 25
- IP pressure test, 10–11

- Lamp control, 23, 30
- Lamp hours, 23, 32, 35

- Maintenance, 6, 33
- Manual control, 23, 35
- Multi-color effect, 23, 28, 35
- Multi-unit power-linking, 31

- NFC, 9, 35
- No DMX status, 18, 22

- Omega bracket, 9, 14

- Pan, 9, 22–23, 27, 32, 34, 35
- Pan/Tilt speed, 22, 29
- Primary-Secondary setup, 22, 31
- Prism rotation, 29
- Prism wheels, 5, 29, 35

- RDM, 5, 22, 32, 35

- Safety cable, 9, 13–15
- Service port, 21
- Shutter, 29
- Strobe, 29, 35
- Sub-GHz, 17, 22
- System menu, 21–23

- Tilt, 9, 22–23, 27, 32, 34, 35
- Torque screws, 10
- Transportation and storage, 13

- UV filter, 5, 8, 12, 27, 35

- Wireless DMX, 5, 17–19, 35

- XLR connector, 25, 31

