

# ETC Assembly Guide

## XDLT Lens Tubes

### Overview

This Assembly Guide describes the placement of lenses in XDLT Lens Tubes, and describes how to safely clean the lenses.

### Lens Markings and Positions

Each lens has a colored dot at its edge on the side of the lens facing the light source. The images below show the position of lenses within the lens tubes. Locations of lenses are also marked on the inside of the lens tube housing.

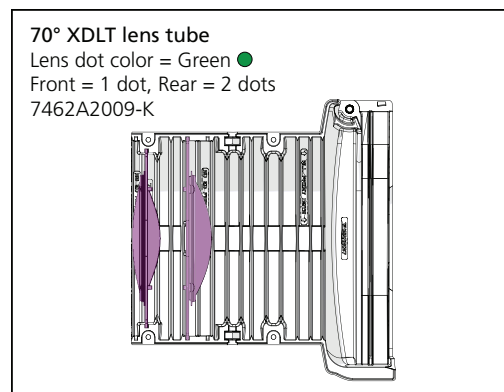
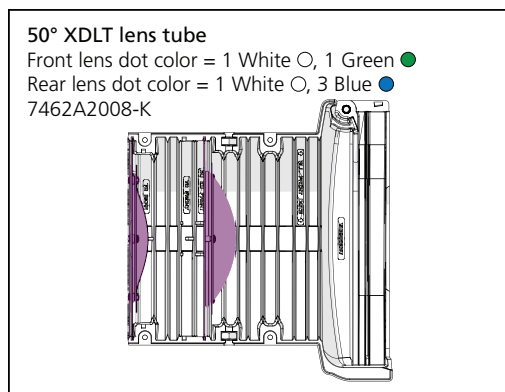
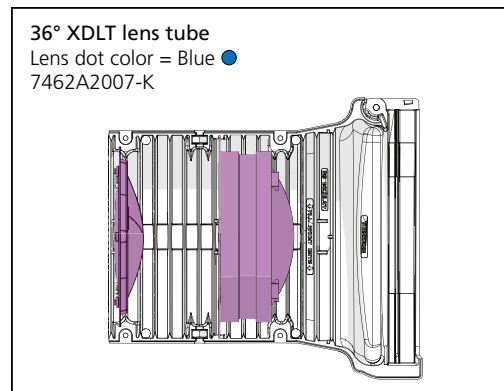
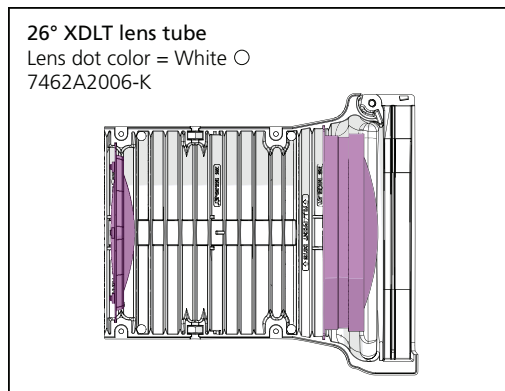
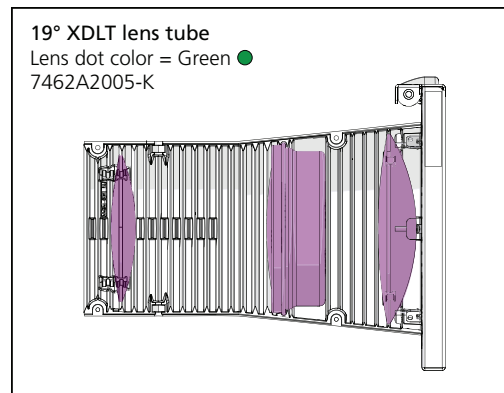
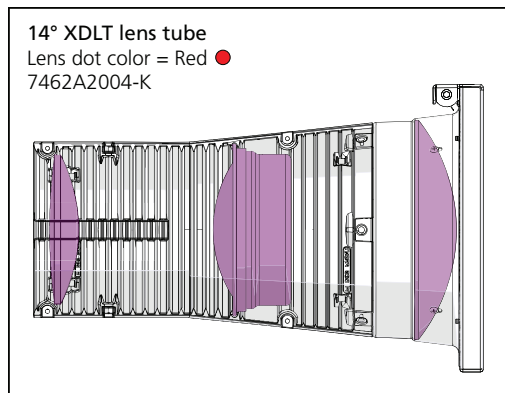

# ETC Assembly Guide

## Lens Tubes

---

### Clean Glass Lenses (14°, 19°, 26°, 36°, 50°, and 70° Lens Tubes)

---



**WARNING:** Do not use ammonia-based cleaners or other harsh commercial cleaners. Clean lens only as directed.

Commercially available glass cleaning agents should be avoided as they may contain ammonia, other harsh chemical detergents or abrasive agents. These cleaners may damage the glass surface and the Anti-Reflective coatings. Do not immerse or soak the glass in any cleaning solution.

---



**WARNING:** For the rear lens in the 19° lens tube, do not use isopropyl alcohol or a mixture that includes isopropyl alcohol to clean the glass surface. Use only distilled water.

---

Remove any dust with a blast of oil-free air or wipe with a clean, lint-free cloth. You can use isopropyl alcohol, distilled water, or a 50%-50% mixture of each to clean the glass surface.

### Clean Polymer Lenses (5° and 10° Lens Tubes)

---



**WARNING:** Handle a polymer lens only by its edges. Never rub anything dry on a polymer lens. Do not use commercial glass cleaners on a polymer lens. Cleaning using commercial glass cleaners will damage the lens.

---

Remove dust with a blast of oil-free air. If this is not sufficient, follow the instructions below.

1. Dip the lens in a clean isopropyl alcohol/water mixture (9 parts water to 1 part isopropyl alcohol).
2. Use a soft moistened nylon bristle brush to wash the smooth side of the lens using a linear (non-circular) motion.
3. Use the same brush to lightly wash the ridged side of the lens by following its ridges.
4. Dip the lens in a clean isopropyl alcohol/water mixture (9 parts water to 1 part isopropyl alcohol).
5. Use an air gun to dry the smooth surface, and then use the air gun to dry the ridged surface. Use the airstream to move the liquid away from you, removing as much liquid as possible.
6. Inspect the lens for dirt. If necessary, repeat the entire process.