

Overview

CXR15 mk3 is a 2-way loudspeaker that delivers the lowest frequencies in its lineup with exceptional clarity, precision, and impressive output capability. This combination of deep low-end and substantial power make it ideal as a main, front-of-house speaker for DJ events or live performances that demand a strong low frequency presence.



Features

- 15" LF + 1.75" HF proprietary high-durability speaker units
- The large-diameter horn secures directivity control across a wide frequency range
- Optimized port positioning reduces standing wave effects
- Lightweight, high-performance, form-injection molded enclosure with a symmetrical, functional design
- Optional UB-DXR15A U-bracket allows both for vertical or horizontal use
- Optional SPCVR-DXR153 speaker cover protects speakers from rigors of equipment transport, lengthy storage, or outdoor performances
- Rigging points for use with eye bolts
- Dual-angle pole sockets offer both 0° or a -7° down tilt

Specifications

General Specifications

Speaker type	2-way Speaker, Bass-reflex	
Frequency range (-10dB)	50 Hz - 20 kHz	
Coverage area	H90° x V60°	
Crossover	1.8 kHz	
Nominal impedance	8Ω	
SPL	Sensitivity (1W; 1m on axis)	95 dB SPL
	Peak (Calculated)	126 dB SPL
Components	LF	Diameter: 15" cone, Voice Coil: 3"
	HF	Diaphragm: 1.75", Type: 1" throat compression driver
Power rating	NOISE	300 W
	PGM	600 W
	PEAK	1200 W
I/O connectors	SpeakON NL4MP x 2 (parallel connected)	
Cabinet material	Plastic (PP)	
Finish	Black	
Handle	Side x2	
Pole socket	Φ35 mm x2 (Bottom, 0° or -7°)	
Rigging	Top x 2, Rear x 1 (Fit for M10 x 18 mm Eyebolts), Bottom x2, Side x 2 (Fit for M8 x 25 mm UB-DXR15A)	
Floor Monitor Angle	52°	
Dimensions	W	447 mm (17.6")
	H	699 mm (27.5")
	D	380 mm (15.0")
Net weight	19.0 kg (41.9 lbs)	
Options	U-bracket: UB-DXR15A, Cover: SPCVR-DXR153	

Dimensions

Unit: mm (inch)

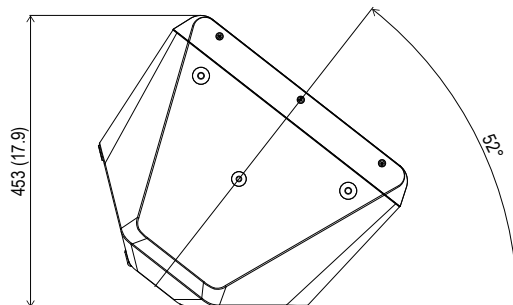
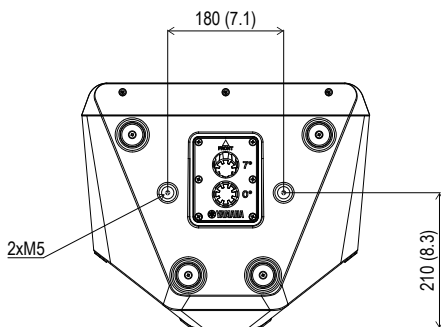
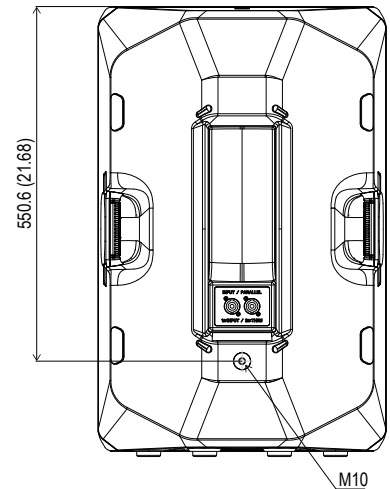
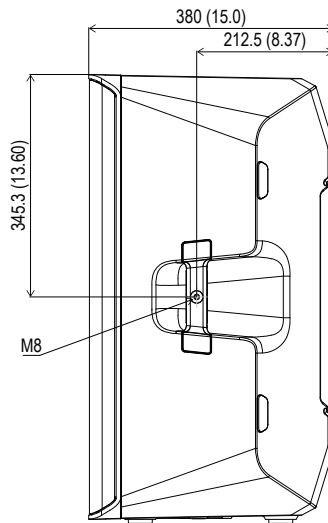
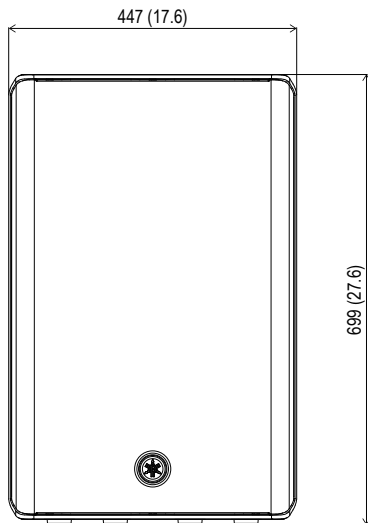
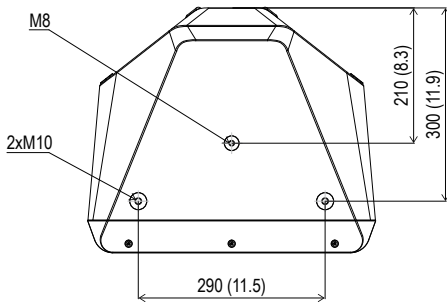

Options

- U-bracket UB-DXR15A
- Cover SPCVR-DXR153

Architectural and Engineering Specifications

The Yamaha CXR15 mk3 shall be a full-range 2-way loudspeaker for sound reinforcement applications, with a bass-reflex type of cabinet. The loudspeaker shall have one 15" cone low-frequency transducer with a 3" voice coil, and one 1" throat high-frequency compression driver with a 1.75" polyimide diaphragm. The crossover frequency shall be 1.8 kHz. The loudspeaker shall be capable of meeting the following performance criteria: reproduction frequency range shall be 50 Hz to 20 kHz (-10 dB); nominal impedance of 8 Ω ; power ratings (IEC noise) of 300 W NOISE, 600 W PGM, 1200 W MAX; sensitivity of 95 dB SPL (1W, 1m) with a maximum SPL (calculated peak, 1m) of 126 dB SPL. Coverage angles shall be 90° horizontal and 60° vertical.

Two speakON NL4MP connectors shall be provided on the rear panel for audio input with wiring for a parallel connection.

The loudspeaker enclosure shall be constructed of form-injection molded black plastic, and shall allow for two angles of pole mounting as well as symmetrical floor monitor use, with a 52° angle. The front grille shall be made of black matte powder coated steel and shall not include any visible mounting screws on the front panel. Rigging points shall be provided for use with standard eyebolts, and optional U Brackets will offer a variety of mounting configurations. The loudspeaker cabinet shall include two handles for convenient lifting. The dimensions of the loudspeaker shall be 447 x 699 x 380 mm (W x H x D). The weight shall be 19.0 kg.

Frequency Response

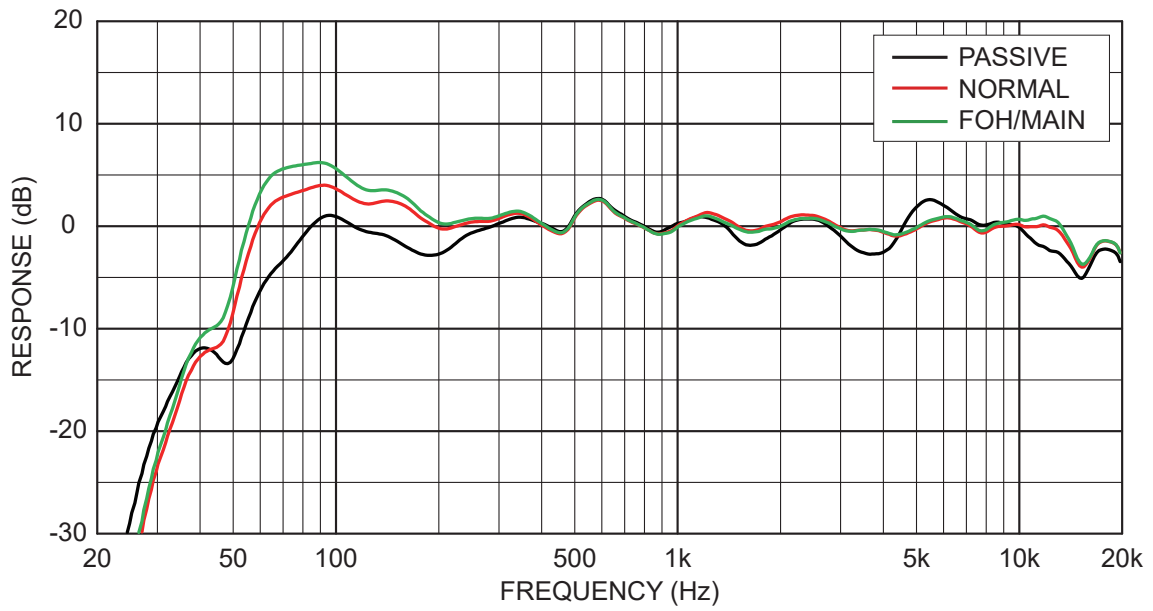

Phase Response

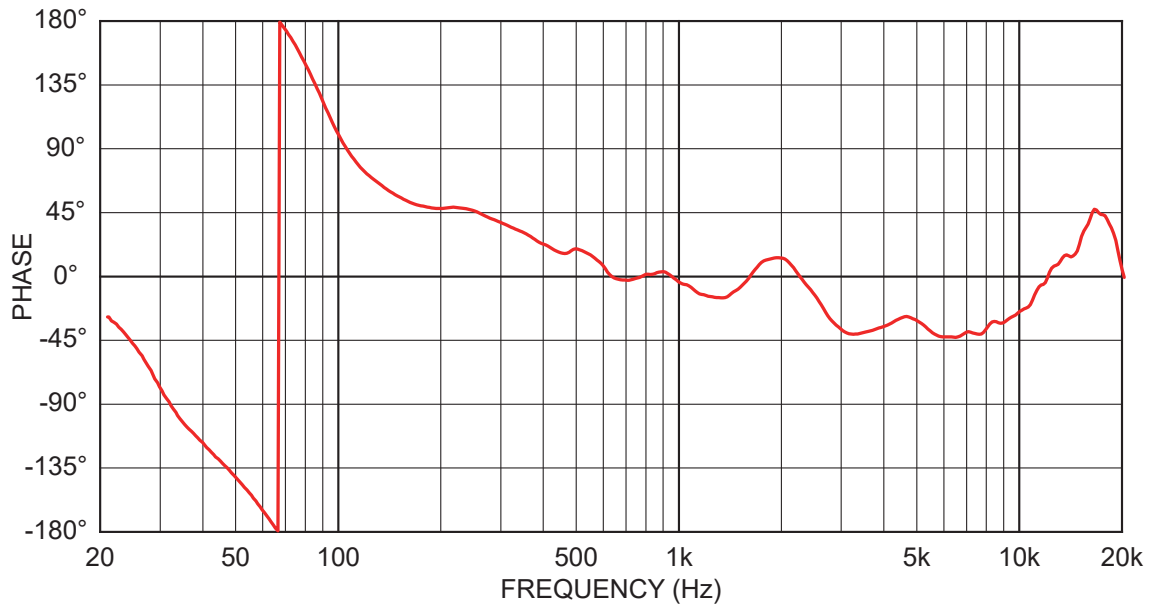

Horizontal Polar Plots

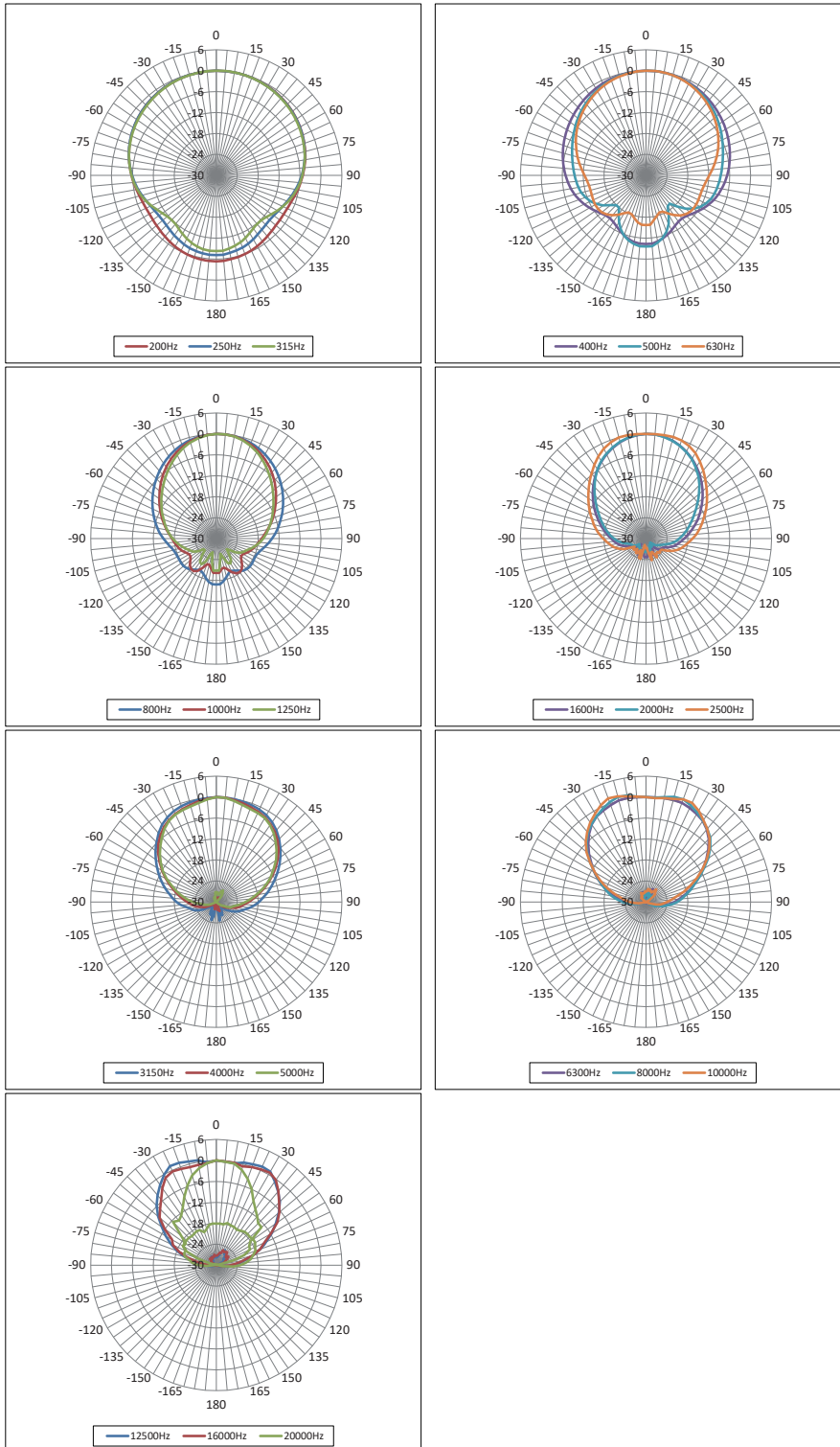

Vertical Polar Plots

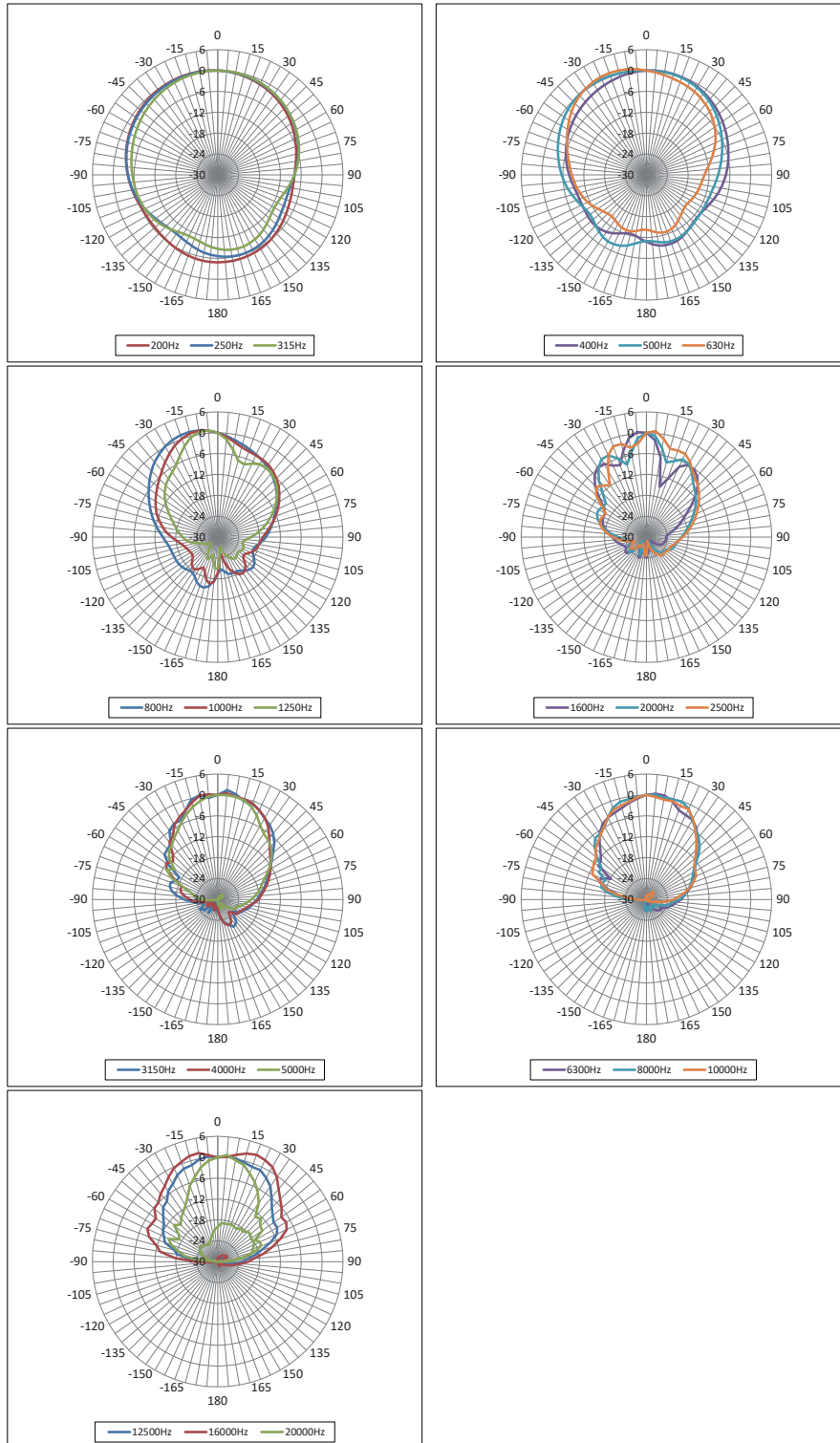

*All information subject to change without notice.

*All trademarks and registered trademarks are property of their respective owners.

Created in April, 2026

YAMAHA CORPORATION
P.O.BOX 1, Hamamatsu Japan