



**biamp.**<sup>TM</sup>

**Vocia**<sup>®</sup>

VACIE Reference Guide

REVISION 1.3  
JUNE 2024

**biamp.**

A: 9300 S.W. Gemini Drive Beaverton, OR 97008 USA

W: [www.biamp.com](http://www.biamp.com)

# Contents

INTRODUCTION.....	3
How to use this Guide .....	3
Section 1 .....	4
VACIE Configuration .....	4
Communications .....	4
Vocia VACIE Devices.....	4
Vocia Support devices .....	5
Power Supply and Network Equipment .....	5
Section 2.....	6
Installation Requirements.....	6
Section 3.....	7
Cabinets .....	7
Section 4.....	8
Cabling.....	8
Maintenance.....	8
Section 5 .....	9
Declarations of Conformity .....	9
Section 6 .....	11
Appendix A - General VACIE Documentation .....	11
Appendix A-1 Vocia VACIE Installer Checklist .....	11
Appendix A-2 Vocia VACIE Communications .....	12
Appendix A-3 Vocia VACIE Network Infrastructure .....	13
Appendix A-4 Vocia VACIE Power Requirements.....	14
Vocia VACIE Power Requirements .....	14
Appendix A-5 Vocia VACIE Cable Requirements.....	16
Vocia VACIE Minimum Cable Specification .....	16
Appendix B - EN54-16 Support Documents.....	17
Appendix B-1 Features And Functions Of The Biamp Vocia VACIE .....	17
Appendix B-2 Vocia EN54-16 Installation System Block Diagram.....	20
Appendix B-3 Vocia VACIE Power Requirements .....	22
EN54-16 Compliant Installations .....	22
Appendix B-4 Vocia VACIE Cabinets.....	23

# INTRODUCTION

The Biamp Vocia VACIE (Voice Alarm Control and Indicating Equipment) is designed to provide an emergency announcement and paging system in accordance with the requirements of international standards. The Vocia VACIE includes Control and Indicator Equipment, Multi Channel Amplifiers and optional Emergency Wall Station paging devices. Components of the Vocia VACIE are designed to be housed in separate cabinets to facilitate the diverse requirements of modern emergency announcement systems. Various other non Vocia devices are required to provide power and the network infrastructure required by a Vocia system as specified in the following sections.

The VACIE is a particular implementation of the technically advanced Biamp Vocia product series. Installers and operators of the Vocia VACIE should review the functionality, interconnects and network distribution principles unique to Vocia prior to reviewing the information presented in operation manuals, installation requirements and associated drawings.

This guide is intended to provide users with a reference to the documentation that can provide a good understanding of the system architecture, the purpose and specifications of individual equipment that make up the Vocia VACIE, the operation of the system and the installation processes required.

## How to use this Guide

This guide is organized into several sections as described below. In general, sections 1 through 4 provide summary information that will introduce the general concepts of a VACIE implementation using Vocia. Section 6 provides an appendix with specific information about compliance requirements.

**Section 1 - VACIE CONFIGURATION** provides an overview of structure of a Vocia VACIE configuration, the various elements that comprise the system, the communications between these elements and power supply requirements.

**Section 2 - INSTALLATION REQUIREMENTS** summarizes general installation matters that a system designer must take into account when specifying and installing a Vocia VACIE system.

**Section 3 - CABINETS** discusses requirements for housing the Vocia VACIE and associated equipment.

**Section 4 - CABLING** discusses general interconnection requirements for the Vocia VACIE. **MAINTENANCE** refers to the general product maintenance information available in the product manuals.

**Section 5** - Provides the **Declaration of Conformity**, along with **the EN54-16 Certification** details.

**Section 6 - Appendix** provides details and drawings of specific requirements and methods that must be applied for general Vocia VACIE installations (Appendix A) and for EN 54-16 compliance (Appendix B).

# SECTION 1

## VACIE Configuration

A minimum standard system will service up to four Emergency Zones and requires a single LSI-16/e, at least one Vocia amplifier with channel/s assigned to service the speaker configuration required in the emergency zones, and an optional EWS Paging Station (microphone). These devices are to be powered by certified external battery-backed power supplies (for example according to EN 54-4). These power supplies are not available from Biamp. The VACIE must be supported by network infrastructure including Ethernet Switches, LAN and control and indicator cabling and Vocia End of Line monitoring devices(ELD-1, PLD-1 and PLD-2).

**Refer to Appendix B-2 Vocia EN 54-16 Installation System Block Diagram.**

## Communications

The Vocia VACIE communicates all audio and internal control data using standard Ethernet network equipment and infrastructure. The Control and Indicating Equipment (CIE) inputs/outputs and faults are communicated using discrete control signals.

**Refer to Appendix A-2 Vocia VACIE Communications.**

## Vocia VACIE Devices

Devices that form part of a Biamp Vocia VACIE include those listed below. Note that some devices are required while others are optional as described elsewhere in this guide.

**LSI-16:** Vocia Life Safety Interface device. The LSI-16 facilitates the control, system integrity monitoring and reporting of faults for the Vocia VACIE. VACIE Control and Indicator functions are facilitated by the LSI-16.

**Refer to the LSI-16/LSI-16e manual.**

**LSI-16e:** Vocia enhanced Life Safety Interface device. The LSI-16e provides an additional 16 inputs to the LSI-16.

Refer to LSI-16/LSI-16e manual.

**CI-1:** Vocia Control Interface unit. The CI-1 provides the input of control signals from fire detection equipment (CIE) and directly interfaces with the LSI-16/e. The LSI-16/e and CI-1 are installed as a pair in the same cabinet. **Refer to the CI-1 manual.**

**GPIO-1:** Vocia General Purpose Input Output Device. The GPIO-1 provides an additional 16 monitored inputs and 16 monitored outputs to the VACIE. **Refer to the GPIO-1 manual.**

### **Vocia Amplifiers (VA-2060/VA-2060e/VA-4030/VA-4030e/VA-8150CV/VA-4300CV/VA-8600c):**

Vocia networked audio power amplifiers with integrated digital signal processing. Vocia amplifiers power speakers in the Emergency Zones and store prerecorded emergency announcements. Vocia amplifiers provide speaker line short circuit and ground fault detection and protection to limit the consequence of fault.

- **VA-2060/VA-2060e:** Vocia two channel 60W RMS power amplifier.
- **VA-4030/VA-4030e:** Vocia four channel 30W RMS power amplifier.

The VA-2060e and VA-4030e have the ability to be powered by dual 24 VDC connections in addition to the AC mains power supply. **Refer to the VA-2060 / VA-2060e / VA-4030/ VA-4030e manual. VA-2060/VA-2060e:** Vocia two channel 60W RMS power amplifier.

- **VA-4030/VA-4030e:** Vocia four channel 30W RMS power amplifier.
- **VA-8150CV:** Vocia eight channel power amplifier. The VA-8150CV provides 37.5W RMS continuous power per channel and up to 150W audio power per channel. The EN54-16 power rating is 75W RMS (1 kHz continuous sine wave for 60s).
- **VA-4300CV:** Vocia four channel power amplifier. The VA-4300CV provides 75W RMS continuous power per channel and up to 300W audio power per channel. The EN54-16 power rating is 150W RMS (1 kHz continuous sine wave for 60s).

The VA-8150 and VA-4030e have the ability to be powered by dual 48VDC connections in addition to the AC mains power supply. **Refer to the VA-8150CV / VA-4300CV manual.**

**VA-8600c:** Vocia eight channel power amplifier. The VA-8600c can house up to 8AM-600c amplifier cards. The VA-8600c chassis provides a maximum of 800W RMS (1 kHz continuous sine wave indefinitely). **Refer to the VA-8600/ VA-8600c manual.**

**EWS-4:** Vocia Emergency Wall Station device is a wall mounted paging stations specifically dedicated as an optional emergency microphone. The EWS-4 device provides priority over all announcements (both prerecorded and live non-emergency). **Refer to the Vocia EWS-4/WS-4/EWS-10/WS-10 Paging Station manual.**

**EWS-10:** Vocia Emergency Wall Station 10 device is a wall mounted paging station specifically dedicated as an optional emergency microphone. The EWS-10 device provides priority overall announcements (both prerecorded and live non-emergency). **Refer to the Vocia EWS-4/WS-4/EWS-10/WS-10 Paging Station manual.**

## Vocia Support devices

The following devices support operation of a Vocia VACIE.

**ELD-1:** Vocia End of Line Device. The ELD-1 is not part of the VACIE but is required to support reporting of the integrity of loudspeaker lines. **Refer to the Vocia ELD-1 manual.**

**PLD-1 and PLD-2:** Vocia Passive End of Line Device. The PLD-1 and PLD-2 are not part of the VACIE but are required to support reporting of the integrity of loudspeaker lines. **Refer to the Vocia PLD-1 and PLD-2 data sheet.**

## Power Supply and Network Equipment

The specific requirements for power supplies and network equipment must be met to ensure the standards compliance of the Vocia VACIE. These devices are referred to as devices that support the operation of the VACIE and are manufactured by other vendors.

**Refer to Appendix A-3 Vocia VACIE Network Infrastructure and Appendix A-4 Vocia VACIE Power requirements.**

## SECTION 2

In addition to the Vocola VACIE devices sourced from Biamp, the installer must provide:

### Installation Requirements

In order to ensure that the standards compliance of the Vocola VACIE are not compromised the LSI-16/e, CI-1, VA-2060/e, VA-4030/e, VA-8150CV, VA-4300CV, VA-8600c, GPIO-1 and EWS, the interconnections to the Fire Detection System, power supplies, network infrastructure and other Vocola components must be installed in accordance with the provisions of applicable standards, Biamp Vocola Operation Manuals for each item of equipment, and this guide. The information contained in the appendices of this document is most important. It provides detailed specifications and requirements for component parts of a compliant system.

The Biamp Vocola VACIE must be installed and commissioned by personnel who have completed the Vocola training courses conducted by Biamp Systems. Once the installation and commissioning process is complete, software access to the Vocola VACIE should be restricted to authorized service personnel only.

The separate cabinets of the Vocola VACIE are designed to be connected together in a network and to be powered by external battery-backed power supplies. Power supplies and Ethernet switches which comply with all applicable standards must be provided to support the system and the units interconnected in accordance with those standards.

The system installer should refer to the appendix for a list of standards and specific clauses that apply.

- EN54-4 certified 24V DC battery backed power supplies.
- EN-54-4 certified 48V DC battery backed power supplies (required for VA-8150CV or VA-4300CV).
- Mains Uninterruptable Power Supply (UPS) to power Vocola amplifiers.
- 24V DC Managed Ethernet Switches with fault relay connections to support the LSI-16/e and CI-1.
- Mains or 24V DC powered Managed Ethernet switches to support the GPIO-1s.
- Mains or 24V/48V DC powered Managed Ethernet switches to support the Vocola amplifiers.
- A Power over Ethernet (PoE) Ethernet switch to support the ELD-1 devices.(Ethernet switch port requirements depend on number of ELD-1s installed in a system)
- EN 54-24 certified Loudspeakers

## SECTION 3

### Cabinets

Typically the Vocia VACIE is housed within multiple rack cabinets:

- A cabinet containing the LSI-16/e, CI-1 and associated support devices cabinet; and
- A cabinet containing Vocia amplifiers and associated support devices.
- If GPIO-1s are present, additional cabinets are required.
- If an EWS device is present, an additional cabinet attached to a certified power supply to facilitate remote stand-alone applications.

If multiple Vocia amplifiers are required to drive a large number of loudspeakers servicing an expansive area then additional cabinets may be added as appropriate.

If multiple GPIO-1s are required then additional cabinets may be added as appropriate.

In order to ensure that the Vocia VACIE is able to be installed in a wide variety of physical locations the LSI-16/e, Vocia amplifiers and GPIO-1 are manufactured in IP30 rated enclosures. The EWS devices optional emergency microphone may require an IP30 rated 'wall mount' enclosure in order to meet the requirements of some standards.

To ensure correct operation, the installer must ensure that access level requirements are met. To maintain standards compliance, installers must follow the Biamp installer guidelines. In some circumstances cabinet construction must limit access to rear terminals and wiring of equipment to achieve specified access levels.

**Refer to Appendix B-4 Vocia VACIE Cabinets for specific standards requirements for Vocia VACIE Cabinets.**

## SECTION 4

### Cabling

#### Ethernet and Interconnection

Ethernet and interconnecting cabling must be installed appropriately to support standards compliance of the Vocia System. Specifically, any cabling between devices that are housed in separate cabinets must support the LSI-16/e fault detection strategy. In order to comply, two independent Ethernet connections must be maintained between the LSI-16/e, GPIO-1s and the Vocia amplifiers. This will usually require that there are two Ethernet cables run between LSI-16/e and its associated Ethernet switch, between Ethernet switches and the connections to the associated Vocia amplifiers or GPIO-1s. A single connection only is required to each ELD-1, EWS device and to the non-Life Safety components of the Vocia paging system.

**Refer to Appendix A-5 Vocia VACIE Cable Requirements.**

#### Power

The LSI-16/e and CI-1 require a 24V DC power supply to be housed in a separate cabinet. Two 24V cables must be run from the 24V supply to the CI-1 which connects directly to the LSI-16/e. As required, 24V cables may also run from the 24V supply to the GPIO-1 and VA-2060e / VA-4030e. The VA-8150CV and VA-4300CV require a 48V DC power supply to be housed in a separate cabinet. Two 48V cables must be run from the 48V supply to the VA-8150CV / VA-4300CV. An uninterruptible power supply system (UPS) is required for provision of AC power to Vocia amplifiers. UPS devices must be installed in accordance with local power wiring standards/codes and manufacturer's specifications.

**Refer to Appendix A-4 Vocia VACIE Power Requirements.**

#### CIE

The CI-1 and GPIO-1 provide the interface between the CIE and the VACIE. The cables that provide interconnection between the CIE and VACIE should be installed as a cable loom.

#### Fault Monitoring

Typical standards-compliant installations require both an LSI-16/e and CI-1. The LSI-16/e monitors system health and detects alarm and fault inputs. The CI-1 provides an interface to external fault contacts and alarm inputs from the CIE, and also provides an alarm/fault sounder and required control switches.

For installations using an LSI-16, fault relay outputs from the 24V power supplies and from UPS devices must be wired in parallel to the CI-1 power supply and UPS fault input ports. Similarly, fault outputs (relay contacts) from associated Ethernet switches must be wired in parallel to the CI-1s Ethernet fault input port to ensure all Ethernet path faults are monitored.

For Installations using an LSI-16e or GPIO-1, fault relay outputs from 24V power supplies, UPS devices and Ethernet switches may be wired independently to additional inputs provided on the LSI-16e or GPIO-1. These inputs must be configured for appropriate fault indications.

**Refer to Appendix B-1 Features and Functions of the Biamp Vocia VACIE.**

The LSI-16/e has a voltage free relay contact that is closed on system fault detection and when power is removed. For standards compliance, this contact is wired via the CI-1 to provide a fault indication to the CIE. If a CI-1 is not installed (non-compliant installation) the contact may be wired in parallel with any other remote general fault contact to a remote indicator or sounder. Refer to the LSI-16/e and CI-1 manuals.

#### Maintenance

The Biamp Vocia VACIE and supporting devices must be maintained in accordance with manufacturer's specifications. Please refer to the Biamp Vocia manuals and supporting equipment manufacturers manuals.

## SECTION 5

### Declarations of Conformity



The Biamp Vocia VACIE (Voice Alarm Control and Indicating Equipment) models (see Table 1) are EN54-16 compliant and meet the following standards for EN54-16:2008: Fire detection and fire alarm systems for buildings – Part 16: Voice alarm control and indicating equipment:

Certification of Constancy of Performance reports

EU: EN54-16 Certification Report: 2797 CPR 752433

UKCA: EN54-16 Certification Report: 0086 CPR 752435

Declaration of Performance documents can be reviewed by contacting Biamp's compliance department, and referencing the following: DoPVV2024BSI EU, DoPVV2024BSI UK .

Certified with the following options with requirements from EN 54-16 / BS EN 54-16:

- Audible Warning
- Phased Evacuation
- Voice Alarm Condition Output
- Emergency Microphones
- Redundant Power Amplifiers

The company headquarters: Biamp Systems, Ltd., 9300 S W Gemini Drive, Beaverton, OR 97008, USA

The equipment is manufactured at: Biamp Systems, Ltd, 10575 SW Cascade Avenue, Tigard, OR 97223, USA

Table 1

<b>Model</b>	<b>Description</b>
LSI-16	Vocia Life Safety Interface device
LSI-16e	Vocia enhanced Life Safety Interface device
CI-1	Vocia Control Interface unit
GPIO-1	Vocia General Purpose Input Output Device
VA-2060/VA-2060e	Vocia two channel 60W RMS power amplifier
VA-4030/VA4030e	Vocia four channel 30W RMS power amplifier
VA-8150CV	Vocia eight channel power amplifier
VA-4300CV	Vocia four channel power amplifier
VA-8600c	Vocia eight channel power amplifier
EWS-4	Wall mounted paging station dedicated as an optional emergency microphone
EWS -10	Wall mounted paging station dedicated as an optional emergency microphone

*continued on the next page*

## Declaration of Conformity (continued)

Table 2

Harmonized Technical Specification		EN54-16: 2008 / BS EN54-16: 2008
Essential Characteristics	Performance	Clause
<b>Performance Parameters Under Fire Conditions</b>		
Performance under fire condition	Pass	4, 5, 7, 10, 12, 16.5, 16.6, 16.7
<b>Operational Reliability</b>		
Response delay (response time to fire)	Pass	7.1, 7.4, 7.8, 10
Operational reliability		4, 5, 6, 7, 8, 9, 11, 12, 13, 14
<b>Durability of Operational Reliability</b>		
Durability of Operational Reliability: Temperature resistance	Pass	16.4, 16.8
Durability of Operational Reliability: Impact and vibration resistance	Pass	16.11, 16.12, 16.13
Durability of Operational Reliability: Humidity resistance	Pass	8.3.12, 8.3.13, 8.3.14
Durability of Operational Reliability: Corrosion resistance	Pass	16.9, 16.10
<b>Durability of Electrical Stability</b>		
Durability of Operational Reliability: Electrical stability	Pass	16.14, 16.15

## SECTION 6

### APPENDIX A - GENERAL VACIE DOCUMENTATION

#### Appendix A-1 Vocia VACIE Installer Checklist

This checklist provides pre- and post installation checks that must be conducted for Vocia VACIE compliance.

Item	Requirement	Y/N
1	Familiarization with requirements of applicable standards and Biamp instructions.	
2	A standards compliant dual 48V DC power supply to provide power to VA-4300CV, VA-8150CV and 48V managed Ethernet switch.	
3	Provide mains powered PoE Ethernet switch for support devices (ELD-1s)	
4	A lockable cabinet may be required for the EWS device to meet standards compliance. Please refer to the Appendix Table of Contents.	
5	A standards compliant 24V DC power supply attached to the EWS device cabinet to provide power to EWS (if optional paging station is required).	
6	CI-1 has been installed with the LSI-16/e to provide an interface to the CIE.	
7	LSI-16/e, CI-1 and 24V DC managed Ethernet switch is housed in a cabinet that meets access level requirements.	
8	Vocia amplifier/s and Mains Powered Managed Ethernet Switch are housed in a cabinet that meets access level requirements.	
9	A standards compliant dual 24V DC power supply to provide power to VA-2060e, VA-4030e, LSI-16/e, CI-1, GPIO-1 and 24V DC managed Ethernet switch.	
10	A mains output UPS to provide power for Vocia amplifiers and mains powered managed Ethernet switch.	
11	Vocia GPIO-1s and 24V DC Managed Ethernet Switch are housed in a cabinet that meets access level requirements.	
12	LSI-16/e to Fire Detection System Interface.	
13	Ethernet and power cabling as per installation instructions.	
14	Ensure equipment access levels have been provided.	

## Appendix A-2 Vocia VACIE Communications

### Overview

The Vocia VACIE internally communicates using networked audio and control data over standard 100 BASE-TX Ethernet network infrastructure. External communications to the Vocia VACIE from 3rd party vendors are provided using discrete parallel logic interconnections.

### VACIE Inputs from CIE

LSI-16e with CI-1 provides for up to twenty voice alarm inputs (maximum off our voice alarm input switch LSI-16), one voice alarm silence and one voice alarm reset. GPIO-1 may be added to increase the number of voice alarm inputs (up to sixteen per GPIO-1). These inputs and associated circuitry have been designed so that a fault on these inputs will not cause a change of operation. These inputs are activated by a low to high transition. Please note if the CIE provides a voice alarm signal in the form of a pulse train the frequency cannot be greater than 1Hz with a 50% duty cycle.

### Voice Alarm Silence

The voice alarm silence provides the ability to mute all active emergency messages.

To activate a voice alarm silence a low to high transition is required. Upon activation the active emergency messages will immediately mute and remain in this state until either:

1. A second low to high transition is detected and the alarm silence is removed
2. The voice alarm reset is activated

### Voice Alarm Reset

The voice alarm reset provides a reset function to remove all active voice alarms. This input is activated by a low to high transition.

### VACIE Outputs to CIE

The LSI-16/e with CI-1 and the GPIO-1 provide monitored outputs that correspond to the LSI-16/e front panel indicators. Please refer to the LSI-16/e manual for more information relating to general fault, PSU fault, protection fault and path fault outputs.

### Voice Alarm Active

This output provides indication of when an emergency message is playing or when an emergency message has been muted (silenced).

- Constant active output - indicates an emergency message is playing in response to a voice alarm input.
- Cyclic output (1.25Hz) - indicates the emergency message has been muted (silenced).

## **Appendix A-3 Vokia VACIE Network Infrastructure**

Ethernet switches used in Vokia VACIE installations must be chosen to meet the requirements of applicable standards.

### **Electromagnetic Capability (EMC), Immunity Requirements**

The network infrastructure that is part of the VACIE must meet the EMC and immunity requirements specified in applicable standards. Biamp has tested the system with the RuggedCom RS900 series Ethernet Switch, the N-Tron 7018TX Ethernet Switch and the Cisco IE-2000 Ethernet Switch and all are suitable candidates.

### **Managed Switch Requirement**

The Ethernet switch must be managed to facilitate redundant link strategies for the dual Ethernet paths between Ethernet Switches used in the Vokia VACIE.

### **24 VDC Managed Ethernet Switch**

This Ethernet Switch is to be powered from the same dual power supply as the LSI-16/e, GPIO-1 or VA-4030e / VA2060e. The Ethernet Switch must provide a fault relay output connection that monitors the power and port link status of the switch.

### **48 VDC Managed Ethernet Switch**

This Ethernet Switch is to be powered from the same dual power supply as the VA-8150CV / VA-4300CV. The Ethernet Switch must provide a fault relay output connection that monitors the power and port link status of the switch.

**Refer to Appendix B-2 Vokia EN54-16 Installation System Block Diagram.**

### **Mains Powered Managed Ethernet Switch**

This Ethernet switch is to be powered from the same mains powered UPS as the Vokia amplifier.

### **PoE Ethernet Switch**

This Ethernet switch is required to supply power and control data to the ELD-1 (support devices, not part of VACIE). The switch must be IEEE 802.3af compliant and provide enough ports to service the ELD-1 requirements.

**Refer to Appendix B-2 Vokia EN54-16 Installation System Block Diagram.**

## Appendix A-4 Vocia VACIE Power Requirements

The Vocia VACIE requires a combination of 24V DC and mains AC power supplies. These power supplies must comply with local emergency standards for required backup and operation times. They must be installed in accordance with both Biamp Vocia VACIE guidelines, and the equipment manufacturer's guidelines.

- 24 VDC Power Supplies: 24V power supplies that meet applicable standards, to power the LSI-16/e, GPIO-1, VA-2060e, VA-4030e and optional EWS-4 and EWS-10 devices.
- 48 VDC Power Supplies: 48V power supplies that meet applicable standards, to power the VA- 4300CV and VA-8150CV.
- Mains UPS: Mains UPS system that meets applicable local standards/codes, to power Vocia amplifiers.
- Mains Ethernet Switch: Mains powered Managed Ethernet Switch associated with the Vocia Amplifiers (Minimum 5 port).
- 24 VDC Ethernet Switch: 24V Managed Ethernet Switches associated with the LSI-16/e, GPIO-1, VA- 4030e and VA-2060e.
- 48 VDC Ethernet Switch:48V Managed Ethernet Switches associated with the VA-8150CV and VA- 4300CV.
- Mains PoE Ethernet Switch: A PoE Ethernet Switch for ELD-1devices. (Ports depend on number of amplifier channels installed)

## Vocia VACIE Power Requirements

### Biamp Products

<b>LSI-16/e with CI-1</b>	
Nominal Voltage	24 VDC
Tolerance	±20%
Power Consumption	15 W

<b>GPIO-1</b>	
Nominal Voltage	24 VDC
Tolerance	±20%
Power Consumption	15 W

<b>EWS-4 and EWS-10</b>	
Nominal Voltage	24 VDC
Tolerance	-5% +20%
Power Consumption	6 W

<b>VA-4030e, VA-4030, VA-2060e, VA-2060</b>	
AC Voltage	100-240VAC
AC Frequency	50/60 Hz

<b>VA-4030e and VA-2060e only</b>	
DC Voltage	24 VDC
Tolerance	±25%
Power Consumption	150 W

<b>VA-8150CV and VA-4300CV</b>	
AC Voltage	100-240 VAC
AC Frequency	50/60 Hz
- or -	
DC Voltage	48 VDC
Tolerance	-20% +25%
Power Consumption	325 W

<b>VA-8600c</b>	
AC Voltage	110–120 VAC
AC Frequency	50 Hz
- or - (Switch Selectable)	
AC Voltage	220–240 VAC
AC Frequency	60 Hz

## Vocia VACIE Power Requirements (continued)

### 3rd Party Products

<b>Ruggedcom RS900-24</b>	
Nominal Voltage	24 VDC
Tolerance	+20%
Power Consumption	10 W

<b>N-Tron 7018TX</b>	
Nominal Voltage	24 VDC
Tolerance	+25%, -58%
Power Consumption	12.5 W

<b>Ruggedcom RS900-HI</b>	
Nominal Voltage	110- 240 VAC
Tolerance	+20%
Power Consumption	10 W

<b>Cisco IE-2000</b>	
DC Voltage	48 VDC
Tolerance	+25%,-80%
Power Consumption	12.5W(typ.), 17W (max.)

## Appendix A-5 Vokia VACIE Cable Requirements

The minimum cable specification has been provided as a reference for all Vokia VACIE interconnecting cable types and parameters.

**Refer to Appendix B-2 Vokia EN54-16 Installation System Block Diagram.**

<b>Vokia VACIE Minimum Cable Specification</b>					
<b>From</b>	<b>To</b>	<b>Wire Size and Configuration</b>	<b>Insulation</b>	<b>Shielded</b>	<b>Comments</b>
Vokia LSI-16/e Monitored Outputs	CIE	22 AWG, stranded	PVC	Yes	
CIE	GPIO-1	22 AWG, stranded	PVC	Yes	
CIE	Vokia CI-1 and LSI-16e Option A / B Connections	22 AWG, stranded	PVC	Yes	
Vokia LSI-16/e System Fault Relay Output	CIE	22 AWG, stranded	PVC	Yes	
Vokia LSI-16/e RS-232	CIE	9 core, 22 AWG, stranded	PVC	Yes	
24V DC Power Connections (not including VA-4030e and VA-2060e)	24 VDC Power Connections	18 AWG, stranded	PVC	Yes	
24V DC Power Connections for VA- 4030e and VA-2060e	24 VDC Power Connections	12 AWG, stranded (30m maximum)	PVC	Yes	Cable gauge is load dependent
48V DC Power Connections for VA-8150CV and VA-4300CV	48 VDC Power Connections	8 AWG, stranded (30m maximum)	PVC	Yes	Cable gauge is load dependent
Ethernet Connections	Ethernet Connections	4 pair, 26 AWG, stranded, impedance: 100Ω	PVC	Yes	Cat 5e
Vokia amplifier speaker line connections	Speakers	18 AWG, stranded	PVC	No	Cable gauge is load dependent
Vokia VFOM-1	Vokia VA-8600 speaker line connections	18 AWG, stranded	PVC	No	

## APPENDIX B - EN54-16 SUPPORT DOCUMENTS

### Appendix B-1 Features And Functions Of The Biamp Vocia VACIE

The Biamp Vocia VACIE provides voice alarm control and indicating functions to initiate and manage an audible fire or other emergency alarm signal / announcement within a building or other defined space. This may be automatic in response to fire alarm or other signals or manually from an emergency paging station.

The Vocia VACIE is manufactured as stand-alone equipment completely separate to the fire detection and fire alarm Control and Indicating Equipment (CIE, as referenced in EN 54-2). The Vocia VACIE includes Control and Indicator Equipment, Multi-Channel Amplifiers and an optional Emergency Wall Station paging device each of which are designed to be housed in a separate cabinet powered by external EN 54-4 compliant DC power supplies and/or Uninterruptible Mains Power Supplies.

The Vocia VACIE supports three operating conditions.

- The quiescent condition
- The alarm condition
- The fault condition

#### 5.4 Indication of the Supply of Power

The Vocia VACIE displays all the mandatory indications on the front panel of the LSI-16/e. The display is clearly identifiable and conforms to EN 54-16 indication colors, intensity and viewing angles. Power is indicated by a GREEN LED on all cabinets.

#### 7 The Voice Alarm Condition

The Vocia VACIE receives and processes up to eight hundred and twenty alarm signals from the CIE (250 zones maximum) causing the appropriate voice alarm outputs to be activated within 3 seconds. The VACIE will silence all alarms immediately when a silence signal is received from the CIE. The Vocia VACIE will reset all alarms immediately when a reset signal is received from the CIE.

#### 8 Fault Warning Condition

The Vocia VACIE enters the fault warning condition within 60 seconds of any signal being received which is interpreted as a fault.

The presence of faults in specified functions are indicated on the Vocia VACIE as specified in section 8 of EN 54-16.

#### 8.5 System Fault

The Vocia VACIE will generate a system fault whenever:

1. A fault as specified in clauses 14.4 or 14.6 of EN54-16 occurs
2. There is a return from loss of power.

The system fault is indicated by means of the general fault warning indicator, a separate light emitting indicator and a sounder on the Vocia VACIE that remain on until a manual reset is performed.

Faults other than the System Fault are automatically reset when faults are no longer recognized.

### 7.3 Audible Warning (option with requirements)

An audible warning is provided on the CI-1. The audible warning will activate when any fault or voice alarm condition occurs in the Vacia VACIE. The audible warning may be silenced by pressing the sounder silence on the CI-1. If a new voice alarm or fault occurs whilst the audible warning is silenced, the audible warning will revert to the active state.

Note: If an emergency microphone is located near the audible warning, the emergency microphone may be configured (at access level 3) to silence the audible warning during live announcements.

### 7.5 Phased Evacuation (option with requirements)

Phased evacuation delay can be configured independently for each emergency loudspeaker zone. The phased evacuation delay duration can only be configured at access level 3 and there is no provision for manual control of phased evacuation at access level 2.

### 7.9 Voice alarm condition output

A voice alarm active output is provided for remote signaling of a voice alarm condition.

## 12 Emergency microphone(s)

The EWS-4 and EWS-10 emergency microphone can only be configured at access level 3. The EWS device must be housed in a lockable cabinet with provision to view the EWS display with the cabinet door locked.

**Refer to the WS-4/WS-10 and EWS-4/EWS-10 OPERATION MANUAL for more information.**

The emergency microphone(s) provides:

1. **Priority over all inputs, including prerecorded messages;**

The emergency microphone(s) have priority over all announcements (both prerecorded and live non-emergency). Access level 3 configuration also provides four levels of priority for emergency microphone(s).

2. **An emergency microphone control to open the microphone channel, at access level 2;**

Access level 2 personnel are authorized to control the emergency microphone (EWS-4 or EWS-10). The EWS device provides up to ten configured (at access level 3) buttons to select the announcement destination. The microphone channel is opened using the Push-to-Talk (PTT) button on the side of the handheld microphone.

3. **Where a pre-announcement attention drawing signal is provided, an indicator adjacent to the microphone shall show when the signal has finished and live speech can commence;**

The EWS device can be configured (at access level 3) to provide a pre-announcement attention drawing signal prior to a live emergency announcement. The EWS device provides indication about the status of the pre-announcement signal and indicates when the operator can commence a voice announcement.

4. **When the emergency microphone control is operated, any audible indication that might interfere with the use of the microphone shall be automatically muted;**

If an emergency microphone is located near the audible warning, the emergency microphone may be configured (at access level 3) to silence the audible warning during live voice announcements.

5. **Where the VACIE has provision for the connection of more than one emergency microphone, they shall be configurable for priority at access level 3 or 4 and only one emergency microphone shall be active at any one time.**

The emergency microphones (EWS-4 or EWS-10) can be configured (at access level 3) to four levels of priority. Emergency microphones configured at the same priority cannot be active in the same emergency zone at the same time. The EWS display will indicate if an emergency zone is busy (if configured at the same priority level) and will indicate when the emergency zone becomes available.

## 13.6 Accessibility of indicators and controls

Four Access levels are supported by the following mechanisms:

**Level1:** All mandatory indications are visible through transparent locked cabinet doors.

**Level2:** Protected by a lockable cabinet door. Access to system fault reset, system test and sounder silence are available at this level.

**Level 3:** Protected by software password. Access level 3 users have access to change emergency paging priority, change emergency messages and to change the phased evacuation delay. All other software configurations can only be viewed.

**Level 4:** Protected by requirement to be Biamp trained. Access level 4 users have access to all hardware and software components of the Vocia VACIE. Access Level 4 personnel have full software privileges that allow for system configuration changes, firmware updates and other functions that can alter the basic mode of operation of the Vocia VACIE.

## 13.14 Redundant power amplifiers

The Vocia amplifiers provide up to 8 channels of amplification and each channel pair can be configured for redundancy (failover).

The VA-4030/e provides the additional functionality of 3 to 1 redundancy (failover).

The VA-8150CV provides the additional functionality of 7 to 1 or dual 3 to 1 redundancy (failover). The VA-4300CV provides the additional functionality of 3 to 1 redundancy (failover).

The VFOM-1 module(VA-8600c) provides the additional functionality of 7 to 1 or dual 3 to 1 redundancy (failover).

### 13.14.1 The VACIE may have provision for at least one spare power amplifier. In this case:

- a) In the event of the failure of a power amplifier, the faulty amplifier shall be capable of being replaced automatically with a spare amplifier within 10s of the fault being detected;  
The failover channels are externally wired in parallel and if a power amplifier fails the redundant amplifier channel will become active and the failed channel will be disabled.
- b) The spare power amplifier(s) shall have at least the same functionality and output power as the replaced amplifier.  
The power amplifiers are configured automatically to the same functionality and power output when the redundancy feature is enabled during configuration at access level 3.

### 13.14.2 Every fault of an amplifier shall be indicated by the general fault warning indicator as specified in 8.2.

Every fault of the Vocia amplifiers are monitored by the LSI-16/e and indicated by a general fault warning indicator and general fault output.

### 13.14.3 Supervision of the spare amplifier(s) shall be maintained during the functional condition whilst the VACIE is powered by either the mains or standby power supplies.

Supervision is maintained for all amplifiers whilst the Vocia VACIE is powered by either mains or standby power supplies. If a fault condition occurs the Vocia VACIE will indicate a protection fault and a general fault.

# Appendix B-2 Vocia EN54-16 Installation System Block Diagram

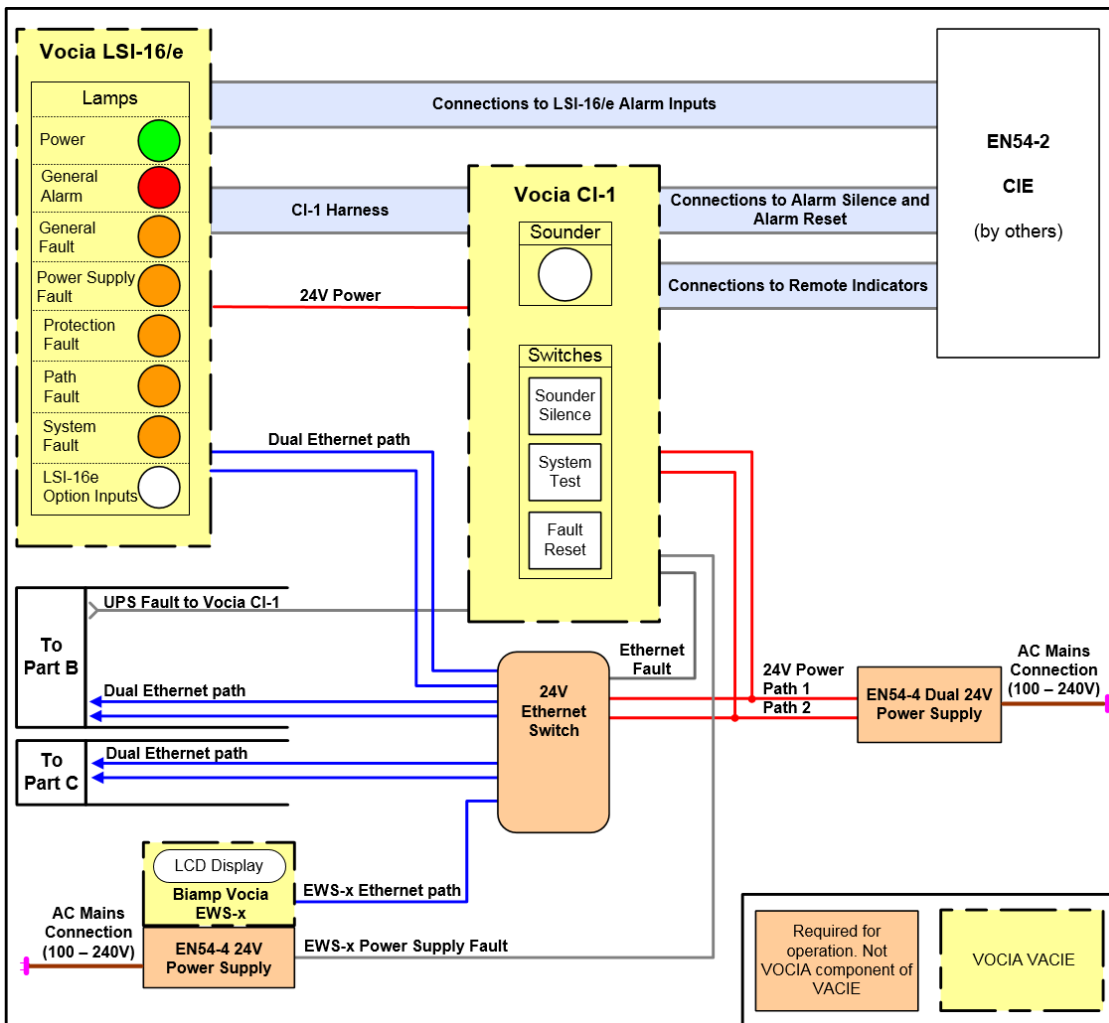

**PART A – EN54-16 Installation System Block Diagram**

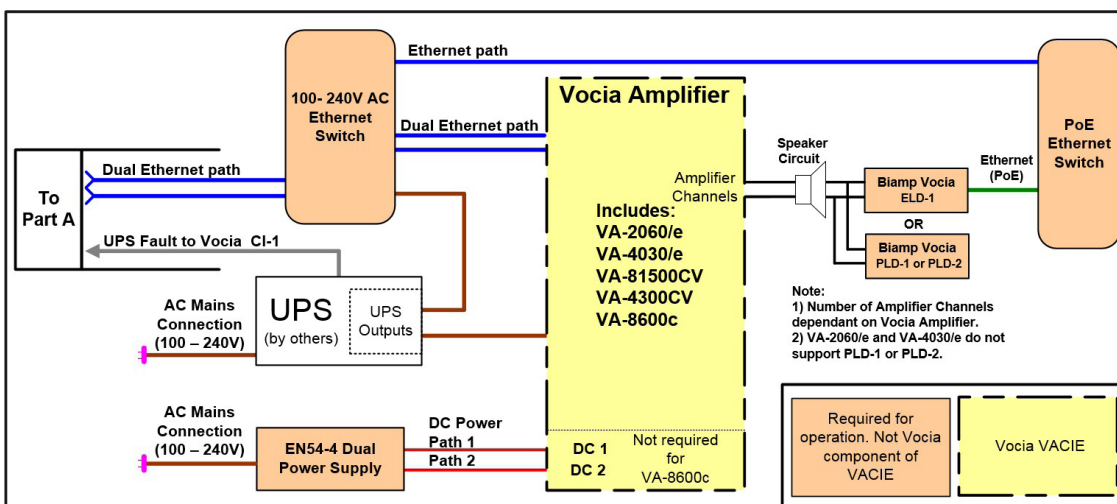

**PART B – EN54-16 Installation System Block Diagram**

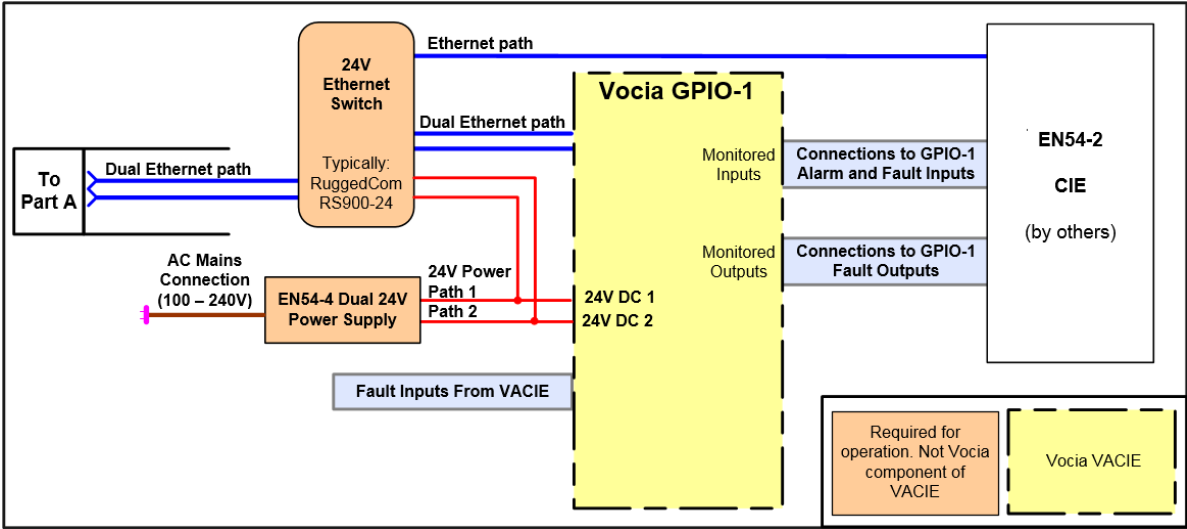

**PART C – EN54-16 Installation System Block Diagram**

## **Appendix B-3 Vocia VACIE Power Requirements**

The Vocia VACIE requires a combination of 24V DC, 48V DC and mains AC power supplies. These power supplies must comply with local emergency standards and must be installed in accordance with both Biamp's VACIE guidelines, and the equipment manufacturer's guidelines.

### **EN54-16 Compliant Installations**

#### **EWS-4 and EWS-10**

A 3rd party EN54-42 4V DC 1A power supply is required for EN54 compliant installations. This power supply shall be housed in the same cabinet as the EWS device. 24V DC Power Supplies must comply with local requirements for run-time on batteries and recharge time.

#### **LSI-16/e and CI-1**

A 3rd party EN54-4 Dual 24V DC 1.2A power supply is required for EN54 compliant installations. This power supply shall be housed in a separate cabinet to the LSI-16/e with interface. 24V DC Power Supplies must comply with local requirements for run-time on batteries and recharge time.

#### **GPIO-1**

A 3rd party EN54-4 Dual 24V DC 1.2A power supply is required for EN54 compliant installations. This power supply shall be housed in a separate cabinet to the GPIO-1. 24V DC Power Supplies must comply with local requirements for run-time on batteries and recharge time.

#### **VA-8600c, VA-4030e, VA-4030, VA-2060e, VA-2060, VA-8150CV and VA-4300CV AC Mains Power**

A 3rd party 240V AC Uninterruptible Power Supply (UPS) is required for EN54 compliant installations. This power supply shall be housed in the same cabinet as the Vocia amplifier or in an adjacent cabinet with common wall structure. Multiple Vocia amplifiers within a common enclosure may be powered from a single UPS of adequate rating. UPS devices must comply with local requirements for run-time on batteries and recharge time. UPS devices and the installations of these devices must also comply with all applicable local or regional standards, norms or codes.

#### **VA-4030e and VA-2060e Auxiliary Power (alternate powering option)**

If optional 24V powering of VA-4030e or VA-2060e amplifiers is installed in an EN54 compliant installation, a 3rd party EN54-4 certified 24V DC 150W (per amplifier) power supply is required. This power supply may be housed in the same cabinet as the VA-4030e /VA-2060e, or alternatively be housed in a separate cabinet to the VA-4030e / VA-2060e. 24V DC Power Supplies must comply with local requirements for run-time on batteries and recharge time.

#### **VA-8150CV and VA-4300CV Auxiliary Power (alternate powering option)**

If optional 48V powering of VA-8150CV or VA-4300CV amplifiers is installed in an EN 54 compliant installation, a 3rd party EN54-4 certified 48V DC 325W (per amplifier) power supply is required. This power supply may be housed in the same cabinet as the VA-8150CV/ VA-4300CV, or alternatively be housed in a separate cabinet to the VA-8150CV / VA-4300CV. 48V DC Power Supplies must comply with local requirements for run-time on batteries and recharge time.

## **Appendix B-4 Vocia VACIE Cabinets**

The Vocia VACIE is designed so that it may be housed in multiple cabinets installed in distributed locations. The requirements for each cabinet are specified in this document in accordance with EN 54-16.

### **LSI-16/e Cabinet**

The LSI-16/e, CI-1 and the supporting 24V Managed Ethernet Switch require a 19" rack cabinet for installation. This cabinet must have a lockable transparent front door to prevent access at Access Level 1 (EN 54-16 Annex A) and to provide visual access to the LSI-16/e indicators. The cabinet must also prevent access at Access Levels 1 and 2 to the internal cabling and connections.

**Refer to Drawing A4.4640\* for a typical cabinet configuration.**

### **GPIO-1 Cabinet**

The GPIO-1 and the supporting 24V Managed Ethernet Switch require a 19" rack cabinet for installation. This cabinet does not require a front door because there are no front panel controls on the GPIO-1. The cabinet must also prevent access at Access Levels 1 and 2 to the internal cabling and connections.

**Refer to Drawing A4.4642\* for a typical cabinet configuration.**

### **Vocia Amplifier Cabinet**

The Vocia amplifier/s and Mains AC or 24V/48V DC powered Managed Ethernet Switch require a 19" rack cabinet for installation. This cabinet does not require a front door because there are no front panel controls on the Vocia amplifiers. The cabinet must also prevent access at Access Levels 1 and 2 to the internal cabling and connections.

**Refer to Drawing A4.4641\* for a typical cabinet configuration.**

### **EWS Cabinet**

The EWS must be housed in a wall mount cabinet. The cabinet must have a lockable transparent front door and have a minimum IP30 (EN60529) rating. The lockable front door is to prevent access at Access Level 1. The cabinet must also prevent access at Access Levels 1 and 2 to the internal cabling and connections. An EN 54-4 compliant power supply (in separate enclosure) must be fixed to the EWS cabinet.

**Refer to Drawing A4.4636 for a typical cabinet configuration**

### **19" Rack Cabinet Specification**

The rack cabinet must be of heavy duty (min. 16-gauge steel) construction with a fully welded rack frame and fixed front mounting members. The cabinet must comply with mechanical dimensions as specified in EN 60297-3-100.

### **IP Rating**

The LSI-16/e, CI-1, GPIO-1 and Vocia amplifier product chassis have been designed to meet the requirements of IP30 (EN60529) and therefore do not require an IP30 rated cabinet for installation.

The EWS requires an IP30 (EN60529) rated cabinet to meet the requirements of EN54-16.

**Please refer to EN54-16 Annex A for an explanation of access levels.**

---

## Resources:

Cornerstone: [support.biamp.com/Vocia](https://support.biamp.com/Vocia) (Vocia Articles)

User Manuals: [biamp.com/support/downloads](https://biamp.com/support/downloads) (Search for product user manual)

## CONTACT US

Email: [support@biamp.com](mailto:support@biamp.com)

Warranty: [biamp.com/legal/warranty-information](https://biamp.com/legal/warranty-information)

Web: [support.biamp.com](https://support.biamp.com)

Safety & Compliance: [biamp.com/compliance](https://biamp.com/compliance)