



**biamp.**<sup>TM</sup>

**Vocia**<sup>®</sup>

Amplifiers  
VA-8150CV and VA-4300CV  
Installation and Operation Guide



**biamp.**

A: 9300 S.W. Gemini Drive Beaverton, OR 97008 USA

W: [www.biamp.com](http://www.biamp.com)

## PRODUCT DESCRIPTION

The VA-4300CV is a digital networked four channel constant voltage 70V/100V amplifier. It is CobraNet enabled and capable of delivering 300W of audio power per channel. The VA-4300CV also has dual Ethernet ports for redundant CobraNet connectivity, comprehensive failover capabilities, and dual power inputs. The VA-4300CV also has comprehensive failover capability with device-to-device and channel-to-channel failover.

The VA-8150CV is a digital networked eight channel constant voltage 70V/100V amplifier. It is CobraNet enabled and capable of delivering 150W of audio power per channel. The VA-8150CV also has dual Ethernet ports for redundant CobraNet connectivity, comprehensive failover capabilities, and dual power inputs. The VA-8150CV also has comprehensive failover capability with device-to-device and channel-to-channel failover.

## SETUP AND INSTALLATION

### Setup and Use

The Vocia software provides an intuitive interface for configuration of the VA-8150CV and VA-4300CV Amplifiers. The information supplied by this manual relates to physical connections and assignment. For more details on software setup, please consult the Vocia Help File (<https://vocia-help.biamp.com/>).

### Installation

The unit requires one 3.5" (89 mm) high (2RU) by 19" (483 mm) wide rack space with 17.5" (444 mm) depth. Mount the unit using four screws with PVC or nylon washers to prevent front panel marring.

Install the unit away from heat sources, such as vents and radiators, and in rooms with adequate ventilation. Ensure that air can circulate freely behind, beside, and above the unit. Do not exceed the maximum ambient operating temperature of 18°-108° F (-8° - 42°C). Be aware of conditions in an enclosed rack that may cause the temperature to exceed ambient room conditions.

## BOX CONTENTS

- Amplifier
- Detachable power cord
- Connectors and plugs
- Cable ties
- Documentation

## YOU WILL NEED

- Wire stripper
- Hardware and tools to attach unit to rack
- Small straight screwdriver (2.5-3 mm)
- Vocia Software

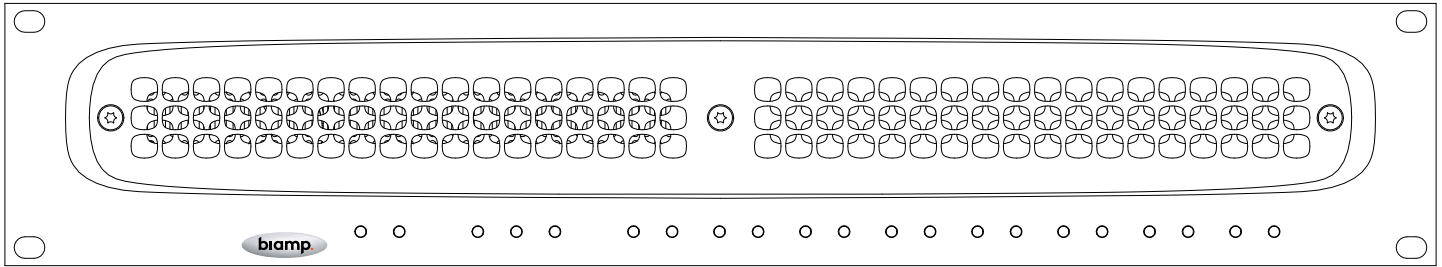

### System Indicators

The LED indicators on the front panel of the amplifier provide information and operational status of the amplifier and its associated output channels. LED layout and features vary between amplifier models. LED's are grouped to show chassis status indication and amplifier channel status indication. Please see the Front Panel View section for details on the different configurations between the various amplifier models.

### Amplifier Chassis Indicators

These indicators relate to the entire amplifier unit (chassis).

#### AC Power

AC power is a green LED indicator. This will illuminate when a Mains supply is applied to the unit.

#### DC Power

DC Power is a green LED indicator. This illuminates when an auxiliary DC supply is applied to the unit via either or both Auxiliary power inputs.

#### CAUTION

Refer to the caution in the Rear Panel Auxiliary Power section

### Amp Fault

An amber LED illuminates when a chassis fault has occurred.

- **Flashing Amber LED** - Warning -the amplifier chassis is not operating within normal limits. If the condition causing the Warning is not corrected, chassis failure may occur.
- **Solid Amber LED** - Fault - the amplifier chassis has failed - audio may have stopped.

### Activity

Activity indicates the configuration status of the Amplifier.

- **LED off** - the unit is not active.
- **Green LED** - the unit is configured.
- **Flashing Amber LED** - the unit is active but has no configuration.
- **Amber LED** - the unit is configured as a redundant device in a failover configuration.
- **Red LED** - indicates a configuration load failure.

### Status

Status indicates the health of the amplifier hardware.

- **Green LED** - indicates that the unit powered up normally.
- **Amber Flashing LED** - shown briefly during the power-up self-test.
- **Red LED** - the unit experienced a problem during the power-up self-test.

## Amplifier Channel Indicators

These indicators relate to each amplifier channel.

### Activity

The Activity LED will illuminate when the channel is configured.

- **Green LED** - configured and actively passing audio.
- **Amber LED** - channel is acting as a standby channel for failover applications.
- **Amber flashing LED** - the amplifier channel has failed or there is a speaker line fault and audio may have stopped.

### Signal

The Signal LED will illuminate when the amplifier output channel is configured and passing audio.

- **Green LED** - passing audio within operational limits. Audio levels between -36 dBFS and -6 dBFS.
- **Amber LED** - Passing audio levels between -6 dBFS and -2 dBFS.
- **Red LED** - indicated clipping. Levels above -2 dBFS.

# VA-8150CV / VA-4300CV Rear

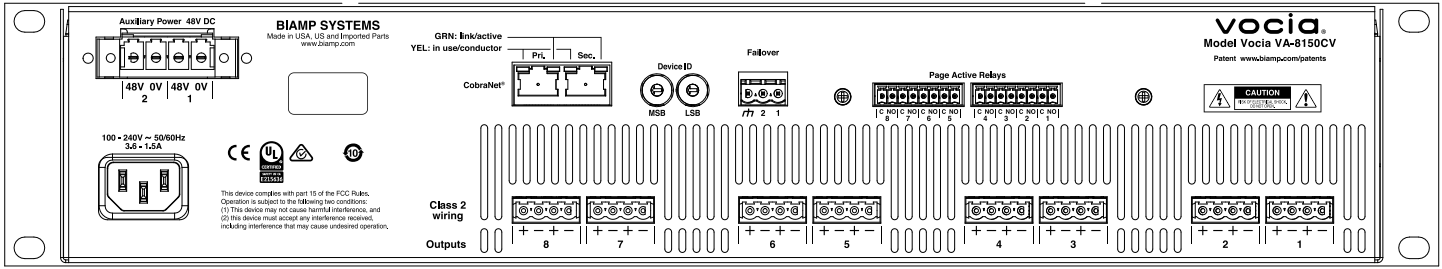

## Conventions

All numbered audio, relay and power connectors on the rear panel of the amplifier are configured with the lowest output or input on the right of the chassis as viewed from the rear of the unit.

## AC Power Socket

Provides for connection of the appropriate power cord. Each amplifier uses a switch mode power supply that has an operating voltage range of 100-240V at 50/60 Hz.

| CAUTION  |
|--|
| Do not remove or defeat the ground prong on the power cord, as this will constitute a shock hazard. Equipment should be connected to a mains socket outlet with a protective earthing connection. This plug is the main disconnecting device and should remain readily operable. There are no user interchangeable parts. Please contact Biamp Technical Support or your local distributor for all service requirements. |

## Auxiliary Power

The VA-8150CV and VA-4300CV support 48V DC Auxiliary power connections.

This Connection allows dual DC power inputs to be used. Dual DC supply capability allows the amplifier to meet standards that call for redundant power supplies. If an amplifier is required to operate without a DC supply, the Auxiliary supply fault monitoring must be disabled in Vocio software. A loss of supply fault is indicated via the Vocio software and by a blinking amber 'Amp Fault' indicator on the front panel of the affected device. The power supplies used for the amplifier must meet the voltage range and current requirements detailed in the specifications table. Local standards, norms or codes may require the use of certified power supplies and may require observance of minimum 'on battery' running times both for standby and maximum power conditions.

| NOTE   |
|--|
| Dual redundant Auxiliary power supplies must each independently meet the total power requirements of the amplifier |

The pluggable terminal blocks provided will accommodate a wire gauge size of 8 AWG maximum. External over-current protection must be provided, according to the current carrying capacity of the connecting wires, and in no case greater than 30 Amps. Do not ground or connect to Chassis either the positive or negative Auxiliary Power connections. The Auxiliary power must be floating with respect to ground.

| CAUTION   |
|---|
| Due to potential energy hazard, connections to the Auxiliary Power DC inputs must be made by a qualified electrician or other qualified person as required to conform with all local codes. |

## Network Connections

The amplifier is a CobraNet device. A Primary and Secondary CobraNet connection is provided for this. All CobraNet routing and bundle assignments are processed by the Vocolta devices locally. Vocolta makes dynamic use of available bundles in CobraNet. A 100Base-T Ethernet switch (not repeater hub) is required when networking multiple units. CobraNet utilizes standard CAT5, CAT5e, CAT6, or CAT7 cabling, which has a specified maximum length of 328 feet (100 meters). Additional Ethernet switches, or switches which provide fiber-optic interface, can be used to extend the physical distance between units within a network. Please note that CobraNet limits network extensions to seven hops (one-way transmissions) within a network. The CobraNet network connection is configured with the primary connector on the left and the secondary (redundant) connector on the right. The primary and secondary CobraNet ports are provided to facilitate connection redundancy. Each connector provides two LEDs that indicate Ethernet link and network activity.

| Left LED        | Right LED      | Description  |
|-----------------|----------------|--|
| None            | None           | No Data Connectivity or CobraNet activity  |
| None            | Green          | Link established   |
| Flashing yellow | Green          | Link established and CobraNet activity detected;<br>The unit is acting as a CobraNet Performer |
| Flashing yellow | Flashing green | Link established and CobraNet activity detected;<br>The unit is acting as a CobraNet Conductor |
| Flashing yellow | None           | CobraNet fault. Check cabling and configuration for errors                                     |

## Device ID Switches

The VA-8150CV and VA-4300CV units represent separate Vocolta device types.

The rotary ID switches give the unit a unique Device ID. The switches are in hexadecimal format. All units of the same device type must have a unique Device ID to function properly within a Vocolta Paging World. The Factory Default Device ID is 01. A Device ID of 00 is invalid and cannot be used.

To assign a Device ID of hex 07, leave the MSB switch on 0 and turn the LSB switch to 7. Device ID switches should be set using a 0.1" (2.5mm) to 0.12" (3.0mm) flat blade screwdriver.

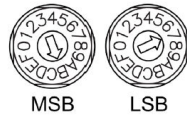

### NOTE

Changes made to the Device ID while connected to the network require a power cycle of the device in order to take effect.

## Device-to-Device Failover

All amplifiers support Device-to-Device amplifier chassis failover in case of fault. The redundant amplifier must be the same model as the primary amplifier. A Failover Link Cable must be connected between the primary and the redundant amplifier as shown below. Connect ground to ground and Pin 1 of the primary amplifier to Pin 2 of the redundant amplifier; connect Pin 2 of the primary amplifier to Pin 1 of the redundant amplifier.

## Page Active Relay

Via the Page Active Relay connectors, one Form A (single pole, changeover) relay is presented per channel on the VA-8150CV. Similarly, two such relays per channel are presented for the VA-4300CV (relays operate in tandem) Each PAR connector is an eight way 3.5mm pluggable screw terminal block. The Page Active relay connections are labeled as follows:

- C – Relay Common.
- NO – Normally Open.

## Amplifier Output Connections

### CAUTION

All Speaker wiring connections should be made by qualified personnel and with the amplifier power removed. The 100V output requires Class 3 wiring. Please refer to a qualified electrician or other qualified person according to local codes.

### Speaker Connection

To minimize power loss, use a speaker cable of appropriate gauge for the load impedance. For long speaker cables, to minimize high frequency loss, choose a low capacitance cable. Use the supplied plug-in barrier strip connectors to connect loudspeaker level outputs. If stranded speaker wire is used, be sure to incorporate all strands into the connector, as stray strands can short to the adjacent terminal or chassis. Do not leave excessive bare wire outside the terminals, as this can lead to shorts. Use of the supplied cable restraints is required to secure the cable in the connector. To facilitate parallel wiring, each connector allows for the connection of two loads to each amplifier channel.

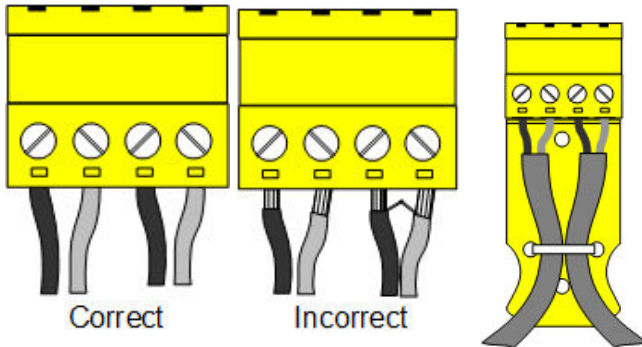

### Rated Load Table

The total output load connected to any channel must not be less than the rated impedance load for that channel, as detailed below. Operating the amplifier in excessive overload may cause power supply safety limiting.

| Model     | 70V Setting | 100V Setting  |
|-----------|-------------|---------------|
| VA-4300CV | 16 $\Omega$ | 33 $\Omega$   |
| VA-8150CV | 33 $\Omega$ | 66.7 $\Omega$ |

## VA-8150CV / VA-4300CV Fault Detection

### Output Fault Detection

Vocia amplifiers employ multiple out-of-band (inaudible), high frequency tones for fault detection. To prevent the possibility of interference with these tones, recorded audio messages or audio content with continuous or swept tonal components (e.g. alert tones) should be band limited at 15 kHz during recording. In addition, signal levels should be adjusted to minimize clipping as severely clipped signals may also affect these out-of-band fault detection tones.

### Failover Modes

The Vocia Amplifiers support a Device-to Device, Channel-to-Channel and 3:1 / 7:1\* failover mode. Only one type of failover mode can be implemented per amplifier.

Failover is triggered by one of the following conditions:

- Chassis fault on primary amplifier
- Channel fault on primary amplifier
- Loss of power to the primary amplifier
- Loss of CobraNet link to primary amplifier
- Loss of Failover Link connection
- ELD-1 / PLD-2 speaker line fault if enabled in software

Only faults (Chassis and Channel) trigger the failover mechanism. Abnormal conditions that do not immediately impair audio appear as warnings, but do not trigger failover.

The redundant amplifier may be wired in parallel to the existing speaker line or it can be connected to a redundant speaker line. Relays isolate the output terminals on the secondary amplifier unit. Relays are normally open. When a configuration is received, relays close on the primary unit and remain open on the redundant unit. On failover, the relay states are reversed.

**\*Note:** 7:1 failover is on VA-8150CV only

### Device-to-Device Failover wiring with Parallel Speaker wiring

After replacing the faulty amplifier, a power cycle is required to recover from failover. This can be done either by physically repowering the amplifiers or by performing a 'device reset' in the Vocia software via the amplifier test tab. The amplifiers are required to be reset within 10 seconds of each other in order for the primary device to resume control.

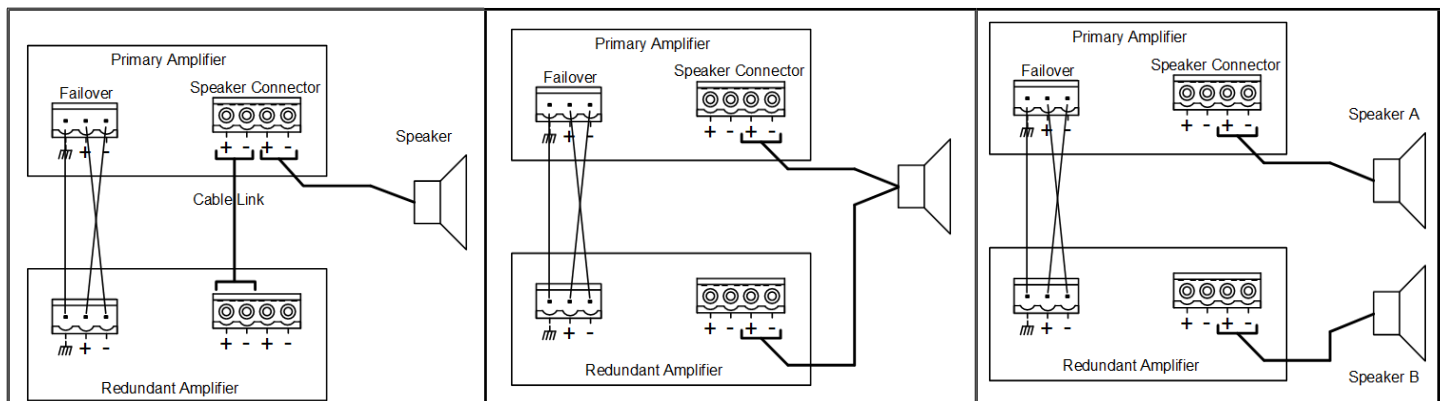

## Channel-to-Channel Failover

All amplifiers support Channel-to-Channel failover. This is configured in the Vocolta Software in the amplifiers General Setting as 1:1 Failover. In this configuration, channel pairs can be specified and adjacent channels will act as a redundant backup.

Channel failover is triggered by one of the following conditions:

- Over temperature
- Short Circuit fault
- Channel Failure fault
- ELD-1 / PLD-2 speaker line fault if enabled in software

The primary amplifier channel will resume control after the fault condition is cleared and the unit is re-powered.

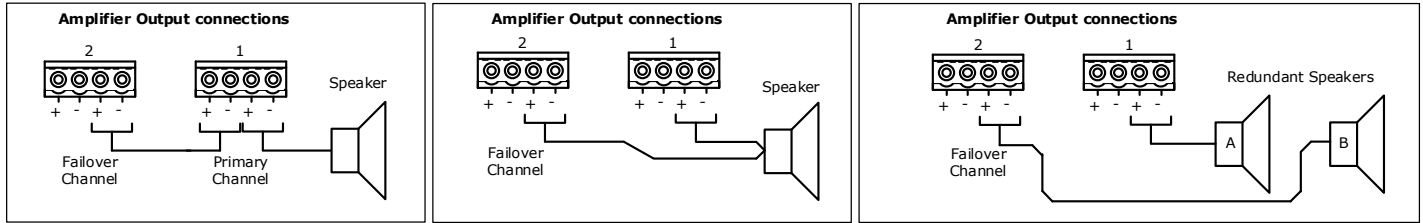

## 3:1 and 7:1 Failover

The VA-4300CV amplifier supports 3:1 channel redundancy. This is configured in the Vocolta Software in the amplifiers general setting as 3:1 failover. In this configuration channel 4 will act as a redundant backup for channel 1, 2 or 3.

The VA-8150CV amplifier supports 2 x 3:1 or 7:1 channel redundancy. This is configured in the Vocolta Software in the amplifiers general setting. In 2 x 3:1 configuration, channel 4 will act as a redundant backup for channel 1, 2 or 3 and channel 8 will act as a redundant backup for channels 5, 6 and 7. In 7:1 configuration channel 8 acts as a redundant backup for channels 1 to 7. The first channel to fail will take priority on the redundant channel.

The primary amplifier channel will resume control after the fault condition is cleared and the unit is again powered.

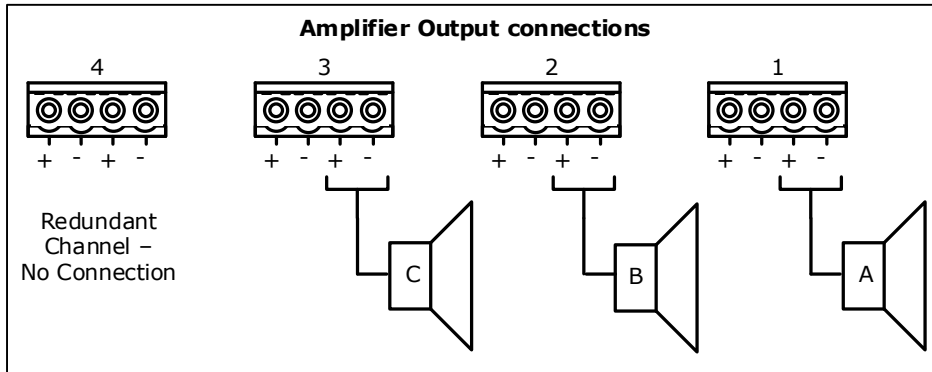

## VA-8150CV / VA-4300CV Current Draw

### AC current draw for 240V operation

|           | TOTAL OUTPUT POWER (Watts) | CONFIGURED CHANNELS | IDLE (Amps) | 1/8 POWER PINK NOISE (Amps) | 1/3 POWER PINK NOISE (Amps) | FULL POWER SINE WAVE (Amps) |
|-----------|----------------------------|---------------------|-------------|-----------------------------|-----------------------------|-----------------------------|
| VA-8150CV | 0 (Not configured)         | 0                   | 0.3         | NA                          | NA                          | NA                          |
|           | 150                        | 1                   | 0.3         | 0.4                         | 0.6                         | 1.1*                        |
|           | 300                        | 2                   | 0.4         | 0.5                         | 0.9                         | 1.9*                        |
|           | 450                        | 3                   | 0.4         | 0.7                         | 1.2                         | 2.7*                        |
|           | 600                        | 4                   | 0.5         | 0.8                         | 1.5                         | 3.6*                        |
|           | 750                        | 5                   | 0.5         | 1                           | 1.8*                        | 4.6*                        |
|           | 900                        | 6                   | 0.6         | 1.2                         | 2.1*                        | 5.5*                        |
|           | 1050                       | 7                   | 0.6         | 1.3                         | 2.4*                        | 6.4*                        |
|           | 1200                       | 8                   | 0.7         | 1.5                         | 2.7*                        | 7.4*                        |
| VA-4300CV | 0 (Not configured)         | 0                   | 0.2         | NA                          | NA                          | NA                          |
|           | 300                        | 1                   | 0.3         | 0.5                         | 1                           | 1.8*                        |
|           | 600                        | 2                   | 0.4         | 0.8                         | 1.6                         | 3.6*                        |
|           | 900                        | 3                   | 0.5         | 1.1                         | 2.3*                        | 5.5*                        |
|           | 1200                       | 4                   | 0.6         | 1.3                         | 3.1*                        | 7.4*                        |

\* Burst mode only. Protective thermal limiting will reduce long-term AC current and continuous power output.

### AC current draw for 100V operation

|           | TOTAL OUTPUT POWER (Watts) | CONFIGURED CHANNELS | IDLE (Amps) | 1/8 POWER PINK NOISE (Amps) | 1/3 POWER PINK NOISE (Amps) | FULL POWER SINE WAVE (Amps) |
|-----------|----------------------------|---------------------|-------------|-----------------------------|-----------------------------|-----------------------------|
| VA-8150CV | 0 (Not configured)         | 0                   | 0.5         | NA                          | NA                          | NA                          |
|           | 150                        | 1                   | 0.7         | 0.9                         | 1.5                         | 2.5*                        |
|           | 300                        | 2                   | 0.8         | 1.3                         | 2.2                         | 4.6*                        |
|           | 450                        | 3                   | 0.9         | 1.7                         | 3                           | 6.8*                        |
|           | 600                        | 4                   | 1.1         | 2.1                         | 3.8                         | 8.9*                        |
|           | 750                        | 5                   | 1.2         | 2.5                         | 4.6*                        | 11.1*                       |
|           | 900                        | 6                   | 1.4         | 2.9                         | 5.4*                        | 13.2*                       |
|           | 1050                       | 7                   | 1.5         | 3.3                         | 6.2*                        | 15.4*                       |
|           | 1200                       | 8                   | 1.7         | 3.7                         | 7*                          | 17.8*                       |
| VA-4300CV | 0 (Not configured)         | 0                   | 0.4         | NA                          | NA                          | NA                          |
|           | 300                        | 1                   | 0.7         | 1.2                         | 2                           | 4.6*                        |
|           | 600                        | 2                   | 0.9         | 1.9                         | 3.7                         | 9*                          |
|           | 900                        | 3                   | 1.1         | 2.6                         | 5.4*                        | 13.6*                       |
|           | 1200                       | 4                   | 1.4         | 3.3                         | 7.1*                        | 17.3*                       |

\* Burst mode only. Protective thermal limiting will reduce long-term AC current and continuous power output.

### DC current draw for 48V operation

|           | TOTAL OUTPUT POWER (Watts) | CONFIGURED CHANNELS | IDLE (Amps) | 1/8 POWER PINK NOISE (Amps) | 1/3 POWER PINK NOISE (Amps) | FULL POWER SINE WAVE (Amps) |
|-----------|----------------------------|---------------------|-------------|-----------------------------|-----------------------------|-----------------------------|
| VA-8150CV | 0 (Not configured)         | 0                   | 0.6         | NA                          | NA                          | NA                          |
|           | 150                        | 1                   | 0.9         | 1.3                         | 2                           | 4.4*                        |
|           | 300                        | 2                   | 1.1         | 2                           | 3.7                         | 8.2*                        |
|           | 450                        | 3                   | 1.4         | 2.7                         | 5.4                         | 12.2*                       |
|           | 600                        | 4                   | 1.7         | 3.5                         | 7.2                         | 16.2*                       |
|           | 750                        | 5                   | 1.9         | 4.3                         | 8.8*                        | 20.1*                       |
|           | 900                        | 6                   | 2.2         | 5.1                         | 10.5*                       | 24.1*                       |
|           | 1050                       | 7                   | 2.5         | 5.9                         | 12.3*                       | 28.1*                       |
|           | 1200                       | 8                   | 2.7         | 6.7                         | 13.9*                       | 32.2*                       |
| VA-4300CV | 0 (Not configured)         | 0                   | 0.4         | NA                          | NA                          | NA                          |
|           | 300                        | 1                   | 0.9         | 1.8                         | 3.2                         | 8*                          |
|           | 600                        | 2                   | 1.3         | 3.2                         | 6.5                         | 15.9*                       |
|           | 900                        | 3                   | 1.7         | 4.6                         | 9.9*                        | 23.8*                       |
|           | 1200                       | 4                   | 2.1         | 6.1                         | 13.1*                       | 31.8*                       |

\* Burst mode only. Protective thermal limiting will reduce long-term DC current and continuous power output

## CONTACT US

Email: [support@biamp.com](mailto:support@biamp.com)

Warranty: [biamp.com/legal/warranty-information](http://biamp.com/legal/warranty-information)

Web: [support.biamp.com](http://support.biamp.com)

Safety & Compliance: [biamp.com/compliance](http://biamp.com/compliance)



A: 9300 S.W. Gemini Drive Beaverton, OR 97008 USA

W: [www.biamp.com](http://www.biamp.com)