



biamp.TM

Vocia[®]

MS-1e
Installation and Operation Guide



biamp.

A: 9300 S.W. Gemini Drive Beaverton, OR 97008 USA

W: www.biamp.com



MS-1E PRODUCT DESCRIPTION

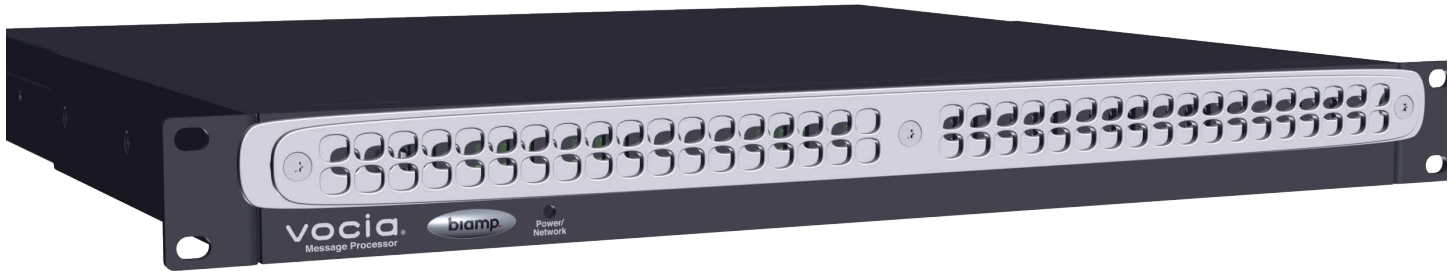

The MS-1e is a networked message processor that supports multiple paging functions within a Vokia system—including message playback, event scheduling, VoIP paging interface, logging and remote access.

CONTENTS

- MS-1e
- Rack Ears (Right & Left)
- Hardware (for rack ear attachment)

NECESSARY SOFTWARE & TOOLS

- Vokia Software (download from [Biamp website](#))
- #2 Phillips screwdriver
- Small (0.12" [3 mm]) flat screwdriver
- [Cornerstone Articles](#) on Vokia systems and hardware

MS-1E SETUP AND INSTALLATION

Setup and Use

The Vokia software provides an intuitive interface for configuration of the MS-1e. The information supplied by this manual relates to physical connections and assignment. For more details on software setup, please consult the [Vokia Help File](#).

Installation

The unit requires one 1.75" (44 mm) high and 19" (483 mm) wide rack space with 17" (432 mm) depth. Mounting the unit using four screws with washers will prevent marring of the front panel. PVC or nylon washers are appropriate. The unit should also be supported at the rear to prevent bending of the enclosure and/or rack ears.

When installing the rack ears, please note that the rack ears are not interchangeable. Please install the rack ear labeled "left" on the left side of the unit (when looking at the equipment facing the front plate) and the rack ear labeled "right" to the right of the unit.

- Remove the screw from the chassis (with a Phillips #2 screw driver)
- Attach the appropriate rack ear and re-affix the Phillips screw to the chassis secure the ear with the included (4) Phillips screws.

Install the unit away from heat sources, such as vents and radiators, and in rooms with adequate ventilation. Ensure that air can circulate freely behind, beside, and above the unit. Do not exceed the maximum ambient operating temperature of 32° to 113° F (0° to 42°C). Be aware of conditions in an enclosed rack that may cause the temperature to exceed ambient room conditions.

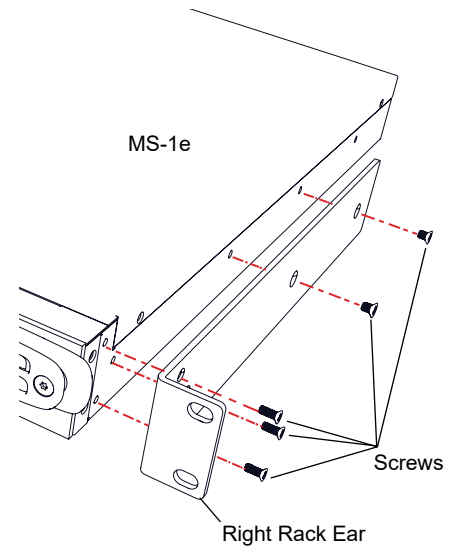

Rack Ear Installation

MS-1E FRONT

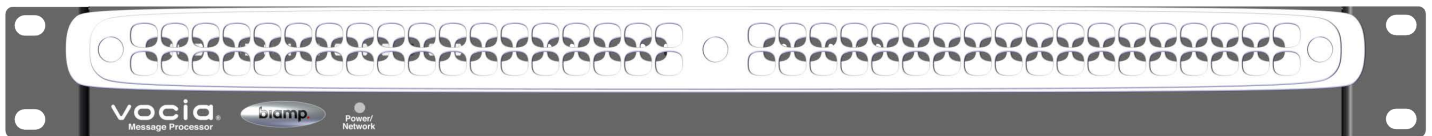

MS-1e Front Panel

The Unit features one power indication LED on the front panel:

- **Not illuminated:** The device is not powered.
- **Flashing green:** The unit is receiving power but not data, or the unit has not been configured correctly.
- **Solid green:** The unit is operational. Power supply and network traffic are functional.

MS-1E REAR

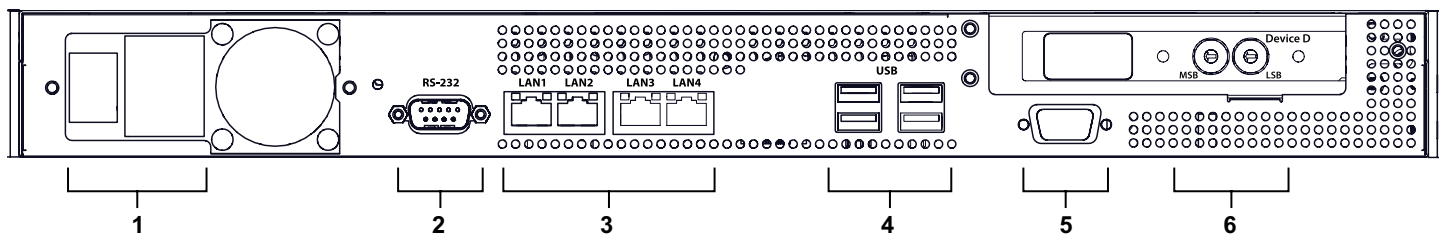

1 - AC Power Entrance (IEC)

The IEC power entrance provides for connection of the appropriate power cord (included with unit). An internal universal switching power supply accepts 100~240VAC @ 50/60Hz, with a maximum power consumption of 350 watts.

CAUTION

Do not remove or defeat the ground prong on the power cord, as this will constitute a shock hazard. Equipment should be connected to a mains socket outlet with a protective earthing connection. This plug is the main disconnecting device and should remain readily operable. There are no user interchangeable parts. Please contact Biamp Technical Support or your local distributor for all service requirements.

2 - RS-232 Port

This port is used to support console access to the MS-1e. This enables third party access to the Vocola MS-VTP (Vocola Text Protocol) API. Please refer to the separate VTP programmers document or the software help file for more details.

3 - Network Connection

The MS-1e has four RJ45 Ethernet connectors located on the rear panel (Control, CobraNet, VoIP, and Live Interworld Streaming). Each connector has two green LEDs, which display Ethernet Link (left LED) and Activity (right LED).

LAN-1 Connector (Control)

This port connects the MS-1e to the Ethernet control network. This should be separate to the LAN that is being used by the CobraNet port either physically or through the use of managed switches and VLANs. The MS-1e can be configured in the Vocola software interface via this port, and as such it should be connected to the same network as the configuration PC during set up. This connection supports Interworld paging and communications. The default IP address of the MS-1e is 192.168.1.101.

LAN-2 Connector (CobraNet)

This port is used to communicate with non-processor Vocola devices and as such should be connected to the same network as the local Vocola system. The data from the CobraNet network should be placed on its own LAN, either physically or through the use of managed switches and VLANs. Unlike other Vocola devices, the MS-1e physical network port does not display LED indication of CobraNet status. By default the MS-1e takes on the role of CobraNet conductor (time sync master).

3. Network Connection (continued)

LAN-3 Connector (VoIP)

This port is used to host VoIP paging functionality for the MS-1e. MS-1e VoIP paging is enabled at the World level. Connection should be made to the same network as other VoIP infrastructure within the facility. If Live Interworld Streaming is enabled (LAN 4) MS-1e VoIP paging functionality (LAN 3) will be disabled at the Universe level.

LAN-4 Connector (Interworld)

This port is used for Live Interworld Streaming. Live Interworld Streaming is enabled at the Universe level. The fourth network interface (LAN-4) on every MS-1e in the Universe will need to be configured with an IP address, subnet mask and optional gateway. This configuration requires the MS-1e hardware to be physically connected on the LAN-4 Network Interface port to a LAN or WAN with a valid connection to the other Worlds. If MS-1e VoIP paging is enabled Live Interworld streaming (LAN-4) will be disabled at the Universe level.

4 - Inactive

These ports are inactive at this time.

5 - Inactive

This port is inactive at this time

NOTE Connection of external devices to inactive ports is not required or recommended.
--

6 - Device ID

The rotary ID switches give the unit a unique Device ID. The switches are in hexadecimal format. All units of the same device type must have a unique Device ID to function properly within a Vocia Paging World. The Factory Default Device ID is 01. A Device ID of 00 is invalid and cannot be used.

To assign a Device ID of hex 07, leave the MSB switch on 0 and turn the LSB switch to 7. Device ID switches should be set using a 0.1 inch (2.5mm) to 0.12 inch (3.0mm) flat blade screwdriver. More information on setting IDs and the hexadecimal numbering scheme can be found in the [Vocia Help File](#).

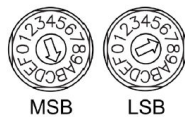

NOTE Changes made to the Device ID while connected to the network require a power cycle in order to take effect.

CONTACT US

Email: support@biamp.com

Warranty: biamp.com/legal/warranty-information

Web: support.biamp.com

Safety & Compliance: biamp.com/compliance



A: 9300 S.W. Gemini Drive Beaverton, OR 97008 USA

W: www.biamp.com