

# Parlé TCM-1 Beamtracking Microphone Installation & Operation Guide



Parlé AVB Beamtracking pendant microphone  
for use with TCM-1, TCM-1A and TCM-1EX



Parlé TCM-1



Parlé TCM-1A



Parlé TCM-1EX

## Product Description

### Parlé™ TCM-1 - Pendant Microphone and Plenum Box

The Parlé TCM-1 is an AVB ceiling microphone for use in Tesira systems. Comprising a pendant microphone and plenum box, each microphone includes Beamtracking™ technology with three 120-degree zones, providing full 360-degree coverage of the meeting space. Each plenum box has its own digital signal processing module and comes with an additional RJ-45 connector for daisy-chain connections. A maximum of three microphones are permitted per daisy chain (one TCM-1 required, plus up to two TCM-1EX).

### Parlé TCM-1A - Pendant Microphone and Amplifier

The TCM-1A is an AVB ceiling microphone and PoE+ amplifier for use in Tesira systems. Comprising a pendant microphone and plenum box, each microphone includes Beamtracking™ technology with three 120-degree zones, providing full 360-degree coverage of the meeting space. The TCM-1A microphone actively tracks and intelligently mixes conversations from around the table, allowing far-end conference participants to experience the conversation naturally.

The 2-channel PoE+ amplifier includes an internal limiter, software configurable amplification, and a “burst” mode to support higher power levels for dynamic content. The TCM-1A comes with its own digital signal processing module for Beamtracking, and each plenum box comes with an additional RJ-45 connector for daisy-chain connections. A maximum of three microphones are permitted per daisy chain (one TCM-1A required, plus up to two TCM-1EX).

### Parlé TCM-1EX - Expander Microphone

The Parlé TCM-1EX is identical to the TCM-1 and TCM-1A microphones and is intended to be used as a second microphone in conjunction with the TCM-1 and TCM-XA. The TCM-1EX cannot operate as a standalone device.



## TCM-1 & TCM-A Front Panels

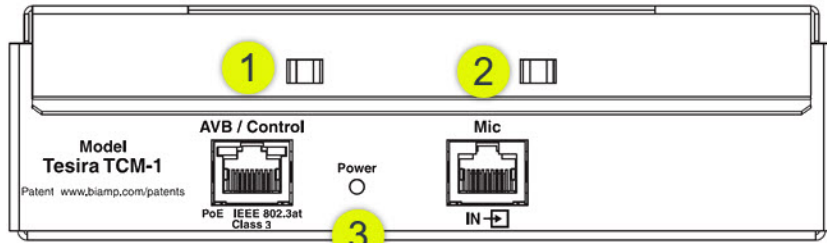

Figure 1. TCM-1

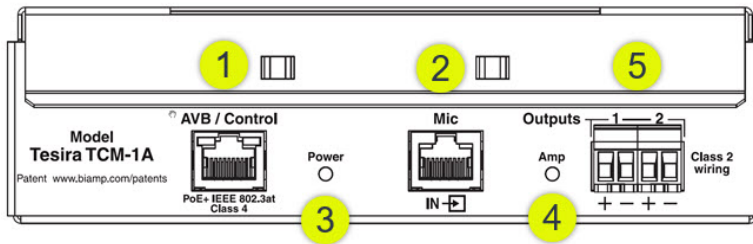

Figure 2. TCM-1A

### Setup and Use

The Tesira software provides an intuitive interface for setup and programming of the TCM-1, TCM-1A and TCM-1EX. The information supplied by this manual relates to physical connections and device setup. For more details on software setup, please consult the [Tesira Help File](#). Note that the pendant microphone is available in black or white. Functionality is identical.

#### 1. AVB/Control

Facilitates connection to the Tesira AVB network for audio transmission and control. This RJ-45 port may either be connected directly to the Tesira AVB port (via a PoE+ injector) for a single device system, or via a PoE+ network switch in a multi-device AVB system. The TCM-1 is an IEEE 802.3 Type 1 Class 3 PoE device requiring 15.4W of PoE power. The TCM-1A is an IEEE 802.3 Type 2 Class 4 device requiring 30W of PoE+ power. There are no other provisions for power inlet.

#### 2. Mic (IN)

Allows up to two additional TCM-1EX expander microphone units in a daisy-chain topology. Use of this RJ-45 port is optional and will depend on the number of additional microphones required to cover the acoustic space.

#### 3. Power LED

A multi-color LED provides information about the status of the device.

Status	LED Indicator
No Power	Off
Booting/Self-Test	Red Solid
Ready to receive configuration or updating firmware	Yellow Solid
Configured and ready to participate in the system	Green Solid
Unit is in Locate mode (triggered by software)	Green Flashing
Unit has a Major Alarm condition	Red Flashing
Unit has a Minor Alarm condition	Yellow Flashing
Unit has both a Major and Minor Alarm condition	Red & Yellow Flashing

#### 4. Amp LED (TCM-1A ONLY)

A multi-color LED provides information about the status of the amplifier.

Status	LED Indicator
No Power	Off
Powered	Green Solid
Amplifier limiter engaged	Yellow Solid
Amplifier is in Locate mode (triggered from the software)	Green Flashing
Amplifier has Major Alarm condition	Red Flashing
PoE+ power is not available or insufficient to power the amplifier so it has been turned off	Red/ & Yellow Flashing

#### 5. Output 1 & 2

2 x 4W RMS or 1 x 8W RMS output at low impedance 4Ω/8Ω.

## TCM-1EX FRONT PANEL

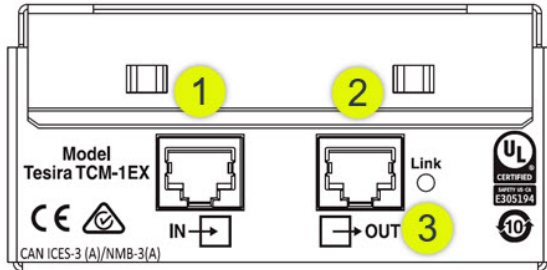

Figure 3. TCM-1EX

### 1. Mic (IN)

Allows for connection of a single additional TCM-EX expander microphone unit in a daisy-chain topology with a maximum of 2 TCM-1EX units per TCM-1 or TCM-1A. Use of this RJ-45 port is optional and will depend on the number of additional microphones required to cover the acoustic space.

### 2. Mic (OUT)

Facilitates connection to the host TCM-1 or TCM-1A unit or can be used to provide a link to the TCM-1EX when used in a multi-microphone daisy-chain topology.

### 3. Link LED

Illuminates when a valid link is detected from the host TCM-1 or TCM-1A.

## TCM-1 MICROPHONE

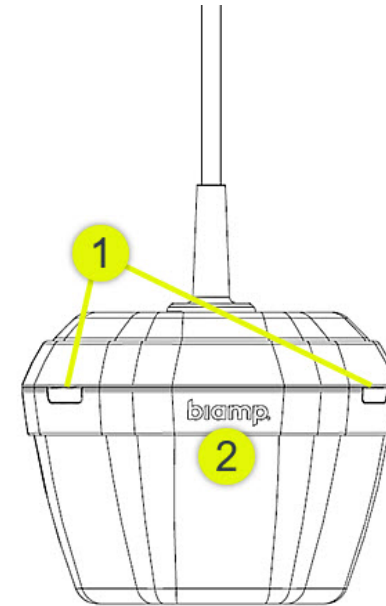

Figure 4. TCM-1, TCM-1A & TCM-1EX Microphone

### 1. LED Indicators

3x multi-color LEDs offset by 120 degrees provide information about the status of the microphone. Default LED indication is shown in the table below. Some LED behavior may be changed during configuration of the software.

Status	LED Indicator
No Power	Off
Configured and operating normally	Green Solid
Unit is in Locate mode (triggered from the software)	Green Flashing
Microphone is Muted	Red Solid
Unit has a Major Alarm condition	Red Flashing

### 2. Biamp Logo

Defines the front of the microphone when looking at the Azimuth Angle in the software.

## Example Topologies

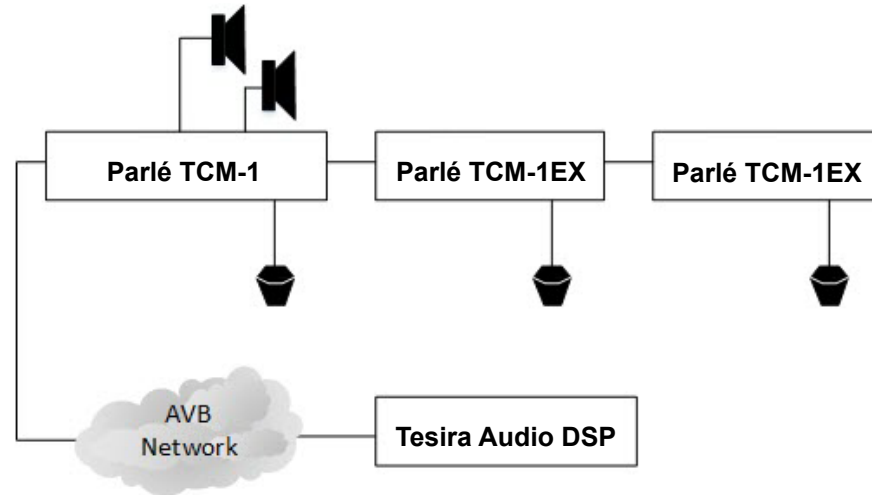

Figure 5. TCM-1A with 2x TCM-1EX

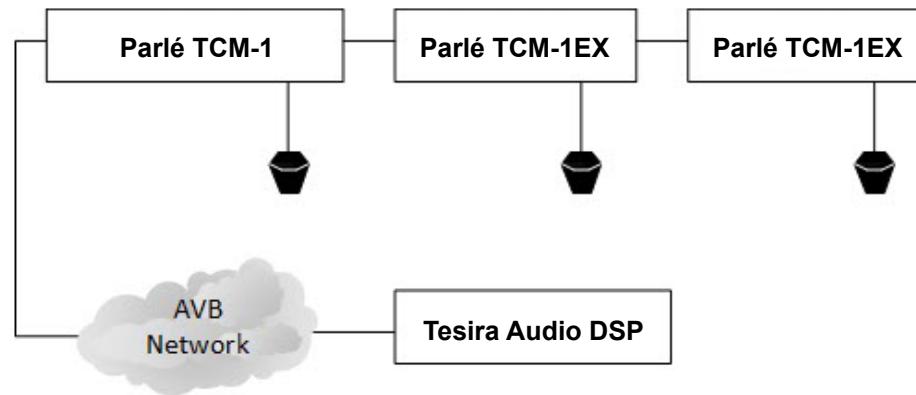

Figure 6. TCM-1A with 2x TCM-1EX

**NOTE:** The TCM-1 and TCM-1A cannot be daisy chained together.

## WIRING TOPOLOGIES

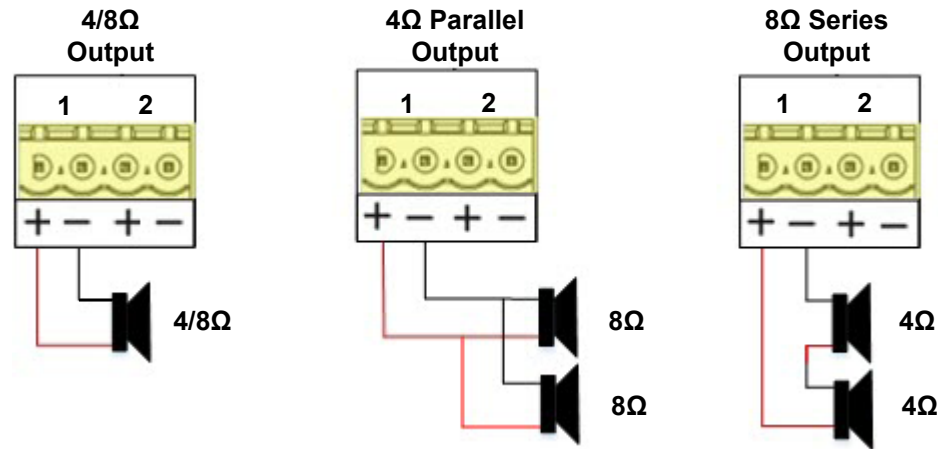

Figure 7. Amplifier speaker wiring (TCM-1A only)

### Channel Assignment & Power Ratings

The amplifier can be configured in either single channel mode in the Tesira software. In 2 channel mode, outputs 1 & 2 will be active and pass audio. In single channel mode, only channel 1 will be active and pass audio. Channel 2 will not pass audio even if a speaker is connected.

**NOTE:** All speaker wiring connections require Class 2 wiring and should be made by qualified personnel with the amplifier power removed.

## Internal Connections

The TCM-1, TCM-1A and TCM-1EX plenum is a folded metal enclosure designed for permanent installation on a ceiling or other horizontal surface, above a ceiling tile, or on a vertical surface. The devices are passively cooled and do not have ventilation ports.

A 2-pin connector is located on the inside of the plenum to connect the pendant microphone. The connector is keyed to prevent incorrect polarity. The microphone is designed to be suspended by the cable. The length of the suspended cable is adjustable by pinching the soft plastic on the under-side of the microphone mount. This allows the cable to be extended or shortened to the desired length.



**Figure 8.** Pinch-Points for Microphone Cable Length Adjustment

Strain relief for the microphone cable should be fitted using the included zip-ties by securing it to either the circuit board (TCM-1EX) or the circuit board protective barrier (TCM-1 & TCM-1A) inside the plenum. Excess cable may be coiled as shown in the figures below.

**CAUTION:** Make sure the cable is not strained or the zip-tie overtightened as damage may occur.



**Figure 9.** TCM-1 & TCM-1A



**Figure 10.** TCM-1 & TCM-1A

Punch-out through-holes in the plenum allow the microphone cable to exit either vertically or horizontally through the microphone mount. Keyed mounting holes allow installation on a vertical or horizontal surface or above a ceiling tile. The plenum design allows for an optional seismic cable to be connected.

If installing the microphone away from the plenum, the cable will be routed through a punch-out through-hole and a strain-relief grommet (included) must be installed to prevent damage to the microphone cable.

**NOTE:** Make sure there's sufficient cable slack outside the plenum to accommodate potential changes in microphone height.



**Figure 11.** Strain-Relief Grommet & Installation

# MOUNTING & INSTALLATION

## General Mounting and Installation Notes

- The maximum distance between an Ethernet switch and a TCM-1 or TCM-1A plenum box is 330 feet (100 meters).
- The maximum distance between daisy-changed TCM plenum boxes is 33 feet (100 meters).
- The maximum adjustable length of the microphone pendant cable is 9.8 feet (3 meters).
- The TCM-1, TCM-1A and the TCM-1EX may be mounted above the ceiling tile or attached to the ceiling or a vertical surface. The devices comply with UL-2043 plenum rating.
- An optional “Tile Bridge” kit (TB-1) may be ordered to facilitate various mounting configurations and accommodate local safety and code requirements.

### Also included:

- 1x microphone mounting large-area washer (pre-drilled for seismic cable installation, if required).
- 1x strain-relief grommet.

## Installation Option - Above Ceiling Tile Mounting

**NOTE:** the plenum cover must be removed for this installation option. No tools required.

1. Cut a .825-inch (21 mm) hole through the ceiling tile where the pendant microphone is to be located. The installer may remove the ceiling tile or cut the hole in place, as desired.
2. Install the microphone mount through the hole in the tile and the plenum. The TCM also includes a large-area washer to accommodate installing the microphone through the ceiling tile in a location away from the plenum.
3. Secure the microphone mount with the retaining hardware (nut) from inside the plenum, or through the ceiling tile and washer depending on the installation.
4. Set the microphone height by using the pinch points on the mount to extend or retract the cable as required.

5. Attach the microphone connector to the socket on the inside of the plenum. If installing the microphone away from the plenum, make sure the strain-relief grommet is installed as shown in [Internal Connections](#).
6. Attach the microphone cable to either the circuit board protective barrier (TCM-1 & TCM-1A) with the provided zip-ties if mounting the microphone internally.
7. Coil any excess cable inside the unit and secure with a zip-tie as shown in [Internal Connections](#) if mounting the microphone internally.  
**CAUTION:** Ensure the cable is not strained or the zip-tie overtightened as damage may occur.
8. Install the plenum cover.

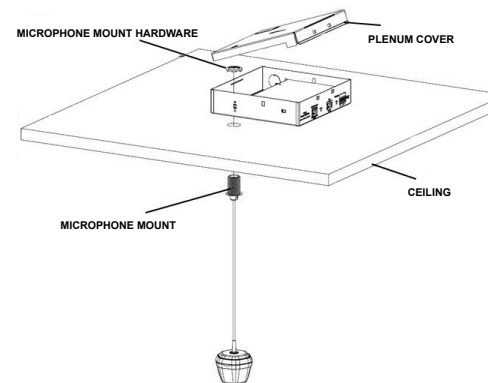

**Figure 12.** Above-Ceiling Tile Installation Option

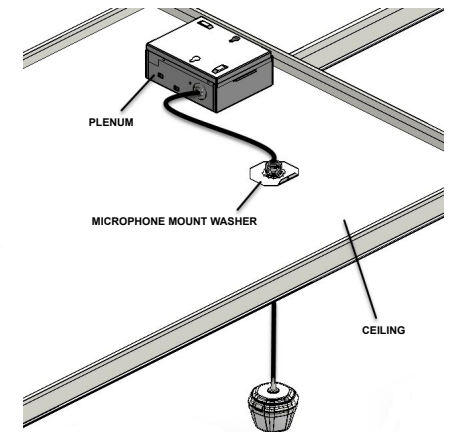

**Figure 13.** Alternate Above-Ceiling Tile Installation Option

## Installation Option - Ceiling Mount

**NOTE:** the plenum cover must be removed for this installation option. No tools required.

1. Attach the plenum cover to the ceiling with hardware through the keyed mounting holes.
2. Install the microphone mount through the hole in the plenum.
3. Secure the microphone mount with the retaining hardware (nut) from inside the plenum.
4. Set the microphone height by using the pinch points on the mount to extend or retract the cable as required.
5. Attach the microphone connector to the socket on the inside of the plenum.
6. Attach the microphone cable to either the circuit board (TCM-1EX) or the circuit board protective barrier (TCM-1 & TCM-1A) with the provided zip-ties.
7. Coil any excess cable inside the unit and secure with a zip-tie as shown in [Internal Connections](#).

**CAUTION:** Make sure the cable is not strained or the zip-tie overtightened as damage may occur.

8. Install the plenum on to the ceiling-mounted cover.

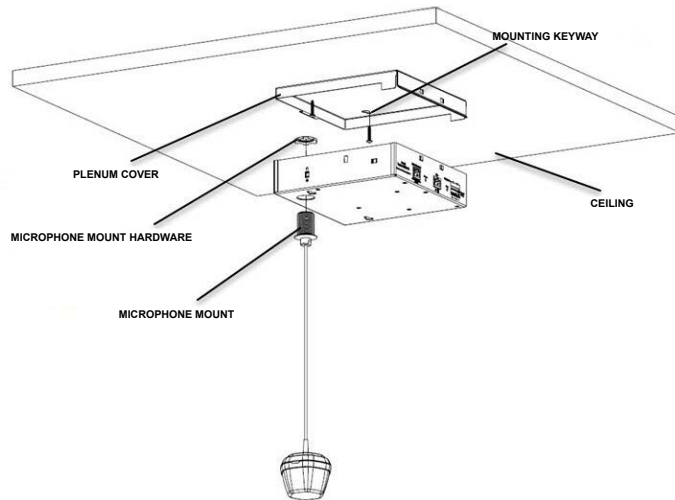

Figure 14. Ceiling Installation Option

## Installation Option - Vertical Mounting

**NOTE:** the plenum cover must be removed for this installation. Not tools required.

1. Attach the plenum to the vertical surface with hardware through the keyed mounting holes.
2. Install the microphone mount through the hole in the plenum.
3. Secure the microphone mount with the retaining hardware (nut) from inside the plenum.
4. Set the microphone height by using the pinch points on the mount to extend or retract the cable as required.
5. Attach the microphone connector to the socket on the inside of the plenum.
6. Attach the microphone cable to either the circuit board (TCM-1EX) or the circuit board protective barrier (TCM-1 & TCM-1A) with the provided zip-ties.
7. Coil any excess cable inside the unit and secure with a zip-tie as shown in [Internal Connections](#).

**CAUTION:** Make sure the cable is not strained or the zip-tie overtightened as damage may occur.

8. Install the cover on to the vertical-mounted plenum.

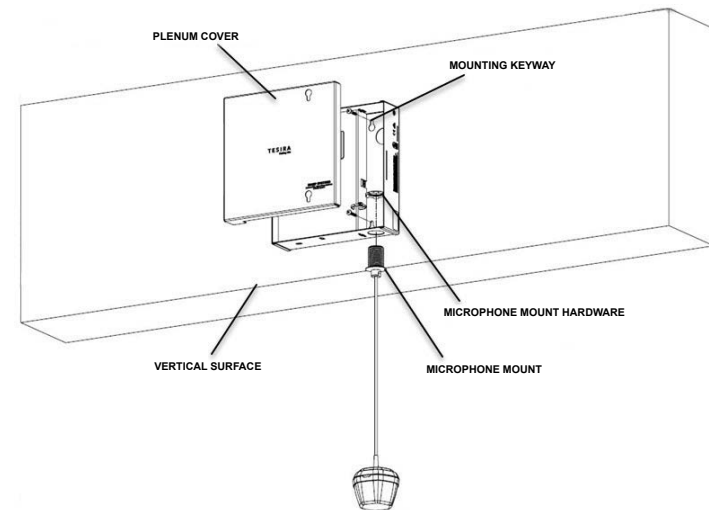

Figure 15. Vertical Surface Installation Option

## Installation Option - Tile Bridge - (TB-1)

The TB-1 Tile Bridge (ordered separately) may be utilized in several configurations to mount the TCM and pendant microphone above ceiling tiles, the most common of which are detailed as follows.

The TB-1 kit includes a tile bridge and two clips that are used to mount any of the TCM model plenum boxes and the pendant microphone. When using the tile bridge to install a microphone, the microphone mounting washer included with the TCM may be discarded.

### For all installation options, do the following:

**NOTE:** For these installations, the strain-relief grommet must be installed on the plenum through-hole where the microphone cable is to be routed. See [Internal Connections](#).

- Remove adjacent ceiling tiles to access the area where the TCM and pendant microphone are to be mounted.
- Cut a .825 inch (21 mm) hole through the ceiling tile where the pendant microphone is to be located.

**NOTE:** Make sure the slots in the tile bridge will line up with the mounting location. The tile bridge may be used as a template to ensure proper location.

## Installation Option - TCM (TB-1) Install

This option installs the TCM in the corner over a ceiling tile where the tile mounting “T-bars” meet.

1. Fit the tile bridge over the ceiling tile where the microphone mounting hole was previously cut. The ends of the tile bridge fit over the ceiling T-bars to secure it in place.
2. Install the clips on the notched fittings of the TCM plenum top cover. See Figure 16 in the previous section.
3. Fit the clips over the T-bars and the TB-1 above the ceiling tile with the TCM oriented as required.
4. Install the microphone mount through the hole in the ceiling and the tile bridge.
5. Secure the microphone mount with the retaining hardware (nut) from above the ceiling tile.
6. Set the microphone height by using the pinch points on the mount to extend or retract the cable as required.
7. Route the microphone cable through the strain-relief grommet and attach the connector to the socket on the inside of the plenum.
8. Coil-up and secure excessive cable with the zip-ties provided.

**CAUTION:** Ensure the cable is not strained or the zip-tie overtightened as damage may occur.

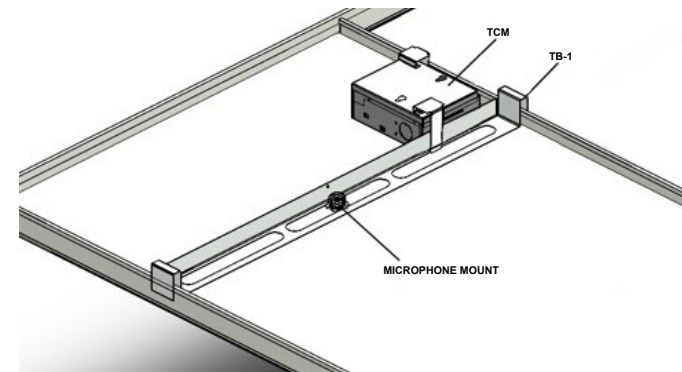

Figure 16. Alternative TB-1/TCM Installation Option

## Installation Option - TCM “Corner” Install

This option installs the TCM in the corner over a ceiling tile where the tile mounting “T-bars” meet.

1. Install the clips on the notched fittings of the TCM plenum top cover.
2. Fit the clips over two perpendicular T-bars (in the corner) above the ceiling tile with the TCM, oriented as required.
3. Fit the tile bridge over the ceiling tile where the microphone mounting hole was previously cut. The ends of the tile bridge fit over the ceiling T-bars to secure it in place.
4. Install the microphone mount through the hole in the ceiling and the tile bridge.
5. Secure the microphone mount with the retaining hardware (nut) from above the ceiling tile.
6. Set the microphone height by using the pinch points on the mount to extend or retract the cable as required.
7. Route the microphone cable through the strain-relief grommet and attach the connector to the socket on the inside of the plenum.
8. Coil-up and secure excessive cable with the zip-ties provided.

**CAUTION:** Ensure the cable is not strained or the zip-tie overtightened as damage may occur.

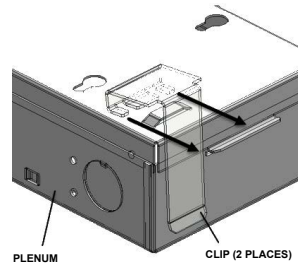

Figure 17. Clip Installation

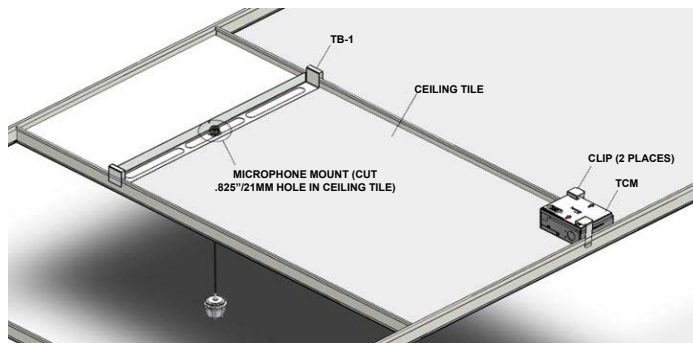

Figure 18. TB-1/TCM Corner Installation

## Other Installation Options

Numerous variations of the previously-detailed installations may be achieved, and it is at the installer's discretion to determine which configuration will satisfy design considerations while complying with any safety or local code regulations.

## Seismic Cable (optional)

Seismic cable(s) (not included) are available for the TCM-1, TCM-1A and the TCM-1EX.

1. To install the seismic cable, locate the holes in the plenum as identified by the arrows. Holes to accommodate the cable are in similar locations for all TCM models.

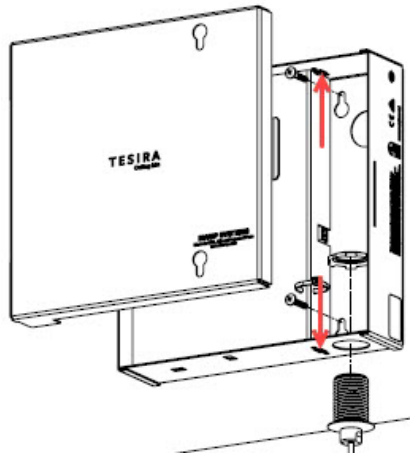

Figure 19. Seismic Cable Installation



Figure 20. End-Stop Installation

2. Feed the cable through the hole in the plenum so the end-stop remains inside.
3. Feed the cable through one end of the locking mechanism.

**NOTE:** the ends indicated by the blue arrow need to be depressed to allow the cable to pass through. Internal guides make sure the cable will be routed through the correct path.

4. Attach the loop to a secure location and apply sufficient tension for minimal slack.
5. Make sure the ends of the lock mechanism are in the locked position (out) as indicated by the blue arrows.

**NOTE:** The tile bridge and large-area microphone mount washer are pre-drilled to accommodate seismic cable installation to comply with local code and/or safety requirements, as required. It is up to the installer to understand and determine these requirements.

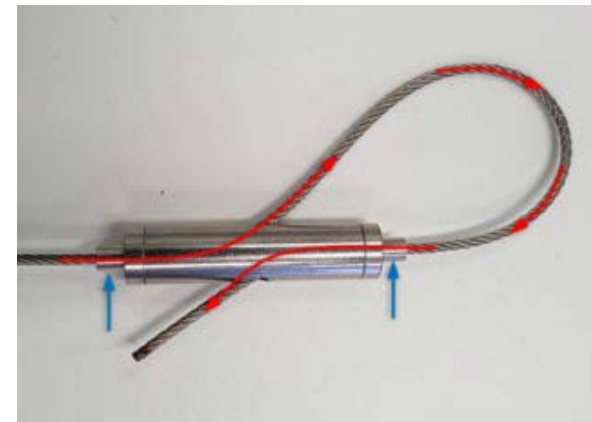

Figure 21. Lock Mechanism Orientation

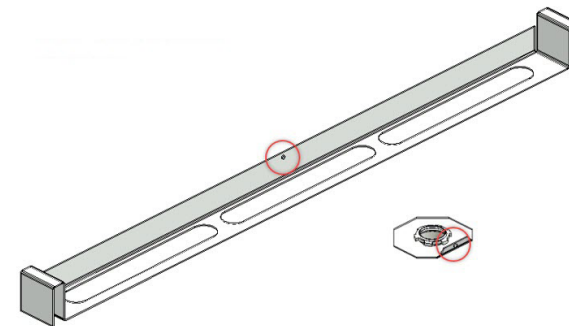

Figure 22. Seismic Cable Attach Points

## CONTACT US

Email: [support@biamp.com](mailto:support@biamp.com)

Warranty: [biamp.com/legal/warranty-information](https://www.biamp.com/legal/warranty-information)

Web: [support.biamp.com](https://support.biamp.com)

Safety & Compliance: [biamp.com/compliance](https://www.biamp.com/compliance)



**A:** 9300 Gemini Drive, Beaverton, OR 97008

**W:** [www.biamp.com](https://www.biamp.com)

31OCT2025