

EX-S6 TWO-WAY COAXIAL 6.5-INCH SURFACE MOUNT LOUDSPEAKER



APPLICATIONS

DISTRIBUTED

Bars and Restaurants · Hotels · Casinos
Shopping Malls · Health and Fitness Clubs
Houses of Worship · Presentation Spaces
Sports Facilities · Outdoor Entertainment
Exhibit Halls · Amusement and Theme Parks

DESCRIPTION

The Desono™ EX surface mount loudspeakers provide excellent acoustic performance in elegant, attractive aesthetics for a diverse range of indoor and outdoor distributed applications. EX Series includes three two-way, full-range models and one matching-enclosure subwoofer. All full-range models include 70 V/100 V transformers and low impedance inputs. They deliver high voice intelligibility, wide bandwidth and exceptional uniform coverage.

The Desono EX-S6, the smallest member of EX Series, 6.5" two-way surface mount loudspeaker provides discreet, distributed sound in applications requiring exceptional audio clarity with a small visual footprint. With its wide coverage angle at 120° and flat response down well below 80 Hz, the EX-S6 is optimal for near-field listening.

Designed for easy and fast installation, our innovative, patented ClickMount™ brackets provide installers with two distinct mounting options. The ClickMount pan-tilt bracket provides indexed aiming control and allows for mounting EX Series quickly in either vertical or horizontal orientation without moving the bracket position. The ClickMount U-Bracket is also available for low-profile mounting or exterior use and includes the ClickPlug with an integrated gland nut for weather-resistant applications. Both brackets are theft and tamper resistant.

FEATURES

- Exceptional audio clarity with small footprint and attractive styling
- Uniform coverage from coaxially mounted HF/LF drivers
- 6-position switch selects 70 V/100 V taps or low impedance bypass
- ETL listed to comply with UL 1480A, CSA 62368-1, CE marked, and RoHS compliant
- EN54-24 and ISO 7240-24 certification

TECHNICAL SPECIFICATIONS¹

Operating Mode	Passive with selectable low-impedance or 70 V/100 V operation		
Operating Environment	Indoor/Outdoor		
Operating Range (-10 dB) ²	58 Hz to 20 kHz		
Nominal Beamwidth (H x V)	120° x 120°		
Transducers	LF 1 x 6.5" (165 mm) treated paper cone HF 1 x 1" (25mm) treated soft dome tweeter w/ waveguide		
Sensitivity ³	@ 1 m	89 dB (2.83 V)	89 dB (1 W, 8Ω)
Nominal Continuous Power Handling ⁴	40 V (200 W, 8Ω Nominal Impedance)		
Nominal Maximum SPL ⁵ (Processed)	@ 1 m	Continuous 112 dB	Peak 118 dB
Rated Continuous Voltage ⁶	31.6 V (30 dBV)		
Rated Maximum SPL ⁷ (Processed)	@ 1 m	Continuous 109 dB	Peak 121 dB
Transformer	70 V: 80 W, 40 W, 20 W, 10 W; 100 V: 80 W, 40 W, 20 W		
Crossover / Protection	1.58 kHz crossover, driver protection circuitry		
Required Accessories	50 Hz, 12 dB / oct. Butterworth high pass filter; DSP preset		
Recommended Amplifiers	200 W - 400 W, 8Ω (40 V - 57 V)		

PHYSICAL

Input Connection	Lever-actuated wire clamping 4-position terminal block with pass-through
Controls	Wattage / low impedance selector switch
Mounting Provisions	ClickMount pan-tilt bracket <i>or</i> ClickMount U-Bracket
Compliance	ETL listed to comply with UL 1480A, CSA STD C22.2# 62368-1, EN54-24, ISO 7240-24, IEC 62368-1
Environmental Rating	IP54 per IEC 60529, IEC 60068-2-5 (Solar Radiation), IEC 60068-2-11 (Salt Mist), IEC 60068-2-42 (SO ₂), IEC 60068-2-60 (Chlorine)
Dimensions H x W x D (including ClickMount)	349 x 217 x 327 mm (13.74" x 8.55" x 12.86")
Dimensions H x W x D (including U-Bracket)	365 x 217 x 253 mm (14.37" x 8.55" x 9.96")
Weight (loudspeaker only)	6.5 kg [14.4 lbs]
Finish	Refer to the Technical Drawings (pages 3-4)
Models (Order by mounting option)	EX-S6-CM [-B,-W] - loudspeaker with small ClickMount pan-tilt bracket EX-S6-UB [-B,-W] - loudspeaker with ClickMount U-Bracket and ClickPlug

OPTIONS

Accessories	CMX-SM [-B,-W] - Small ClickMount pan-tilt bracket kit EXUB-S6 [-B,-W] - EX-S6 ClickMount U-Bracket kit
-------------	--

DESONO

EX-S6

TWO-WAY COAXIAL 6.5-INCH
SURFACE MOUNT LOUDSPEAKER

AXIAL PROCESSED SENSITIVITY (dB SPL)⁸

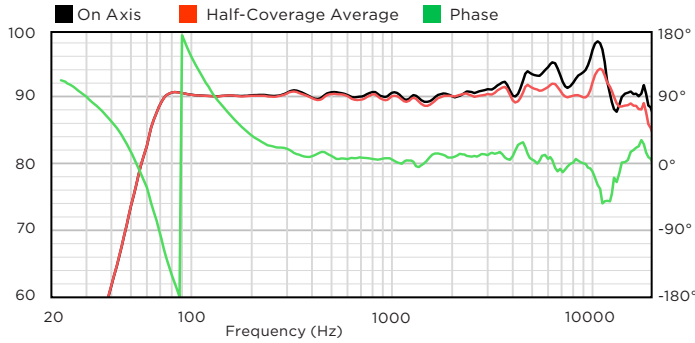

HORIZONTAL OFF-AXIS RESPONSE (dB SPL)⁹

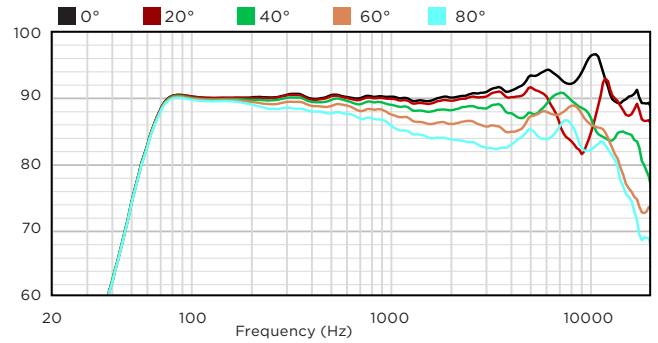

AXIAL SENSITIVITY (dB SPL)⁸

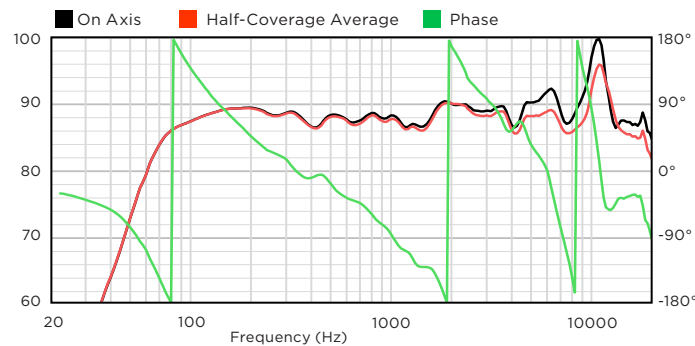

VERTICAL OFF-AXIS UP RESPONSE (dB SPL)⁹

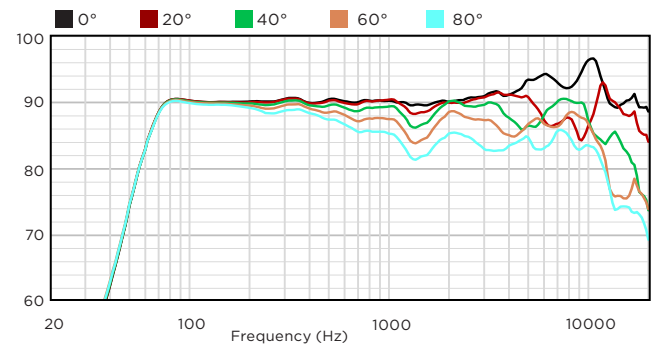

IMPEDANCE (Ω)

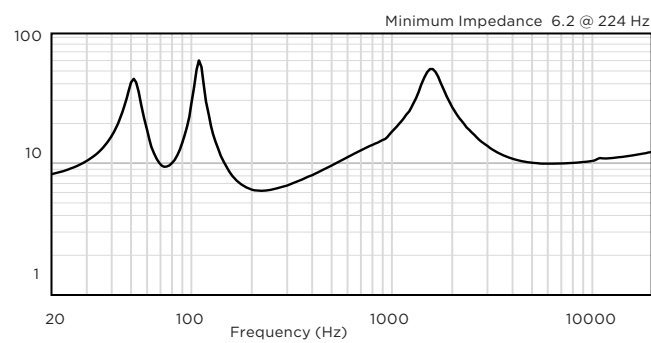

VERTICAL OFF-AXIS DOWN RESPONSE (dB SPL)⁹

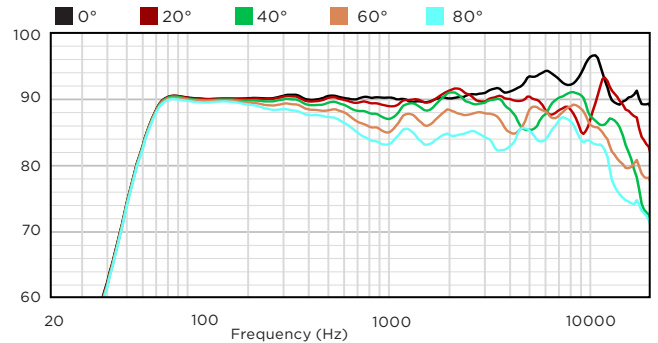

DIRECTIVITY INDEX (dB)¹⁰

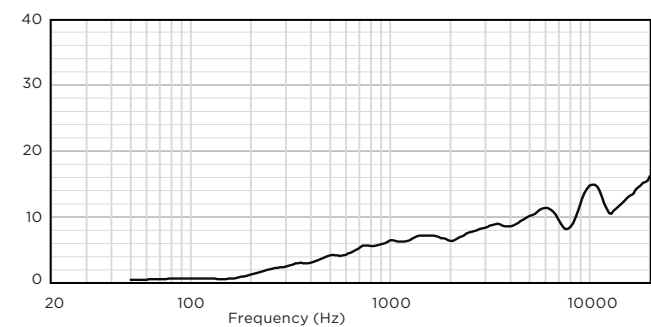

BEAMWIDTH (degrees)¹¹

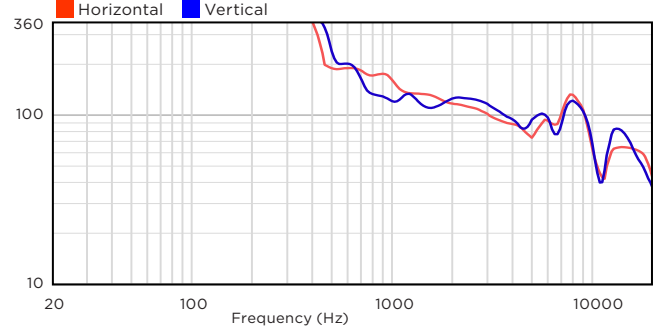

DESONO

EX-S6

TWO-WAY COAXIAL 6.5-INCH
SURFACE MOUNT LOUDSPEAKER

TECHNICAL DRAWING / DIMENSIONS / FINISH [EX-S6-CM]

H x W x D

349 x 217 x 327 mm

[13.74" x 8.55" x 12.86"] (including ClickMount)

Unit Weight

6.5 kg [14.4] lbs loudspeaker only

7.0 kg [15.5 lbs] loudspeaker + bracket

Shipping Weight

8.46 kg [18.7 lbs]

Grille

Powder-coated perforated Marine Grade aluminum backed with hydrophobic cloth
Black or White

Enclosure / Bracket / Finish

High-impact UL94 5VB rated polycarbonate/ABS blend, painted UV resistant matte finish

Bracket: Heavily reinforced glass-filled nylon with UV-resistant painted matte finish cover
Color: Black (RAL 9017) or White (RAL 9016)

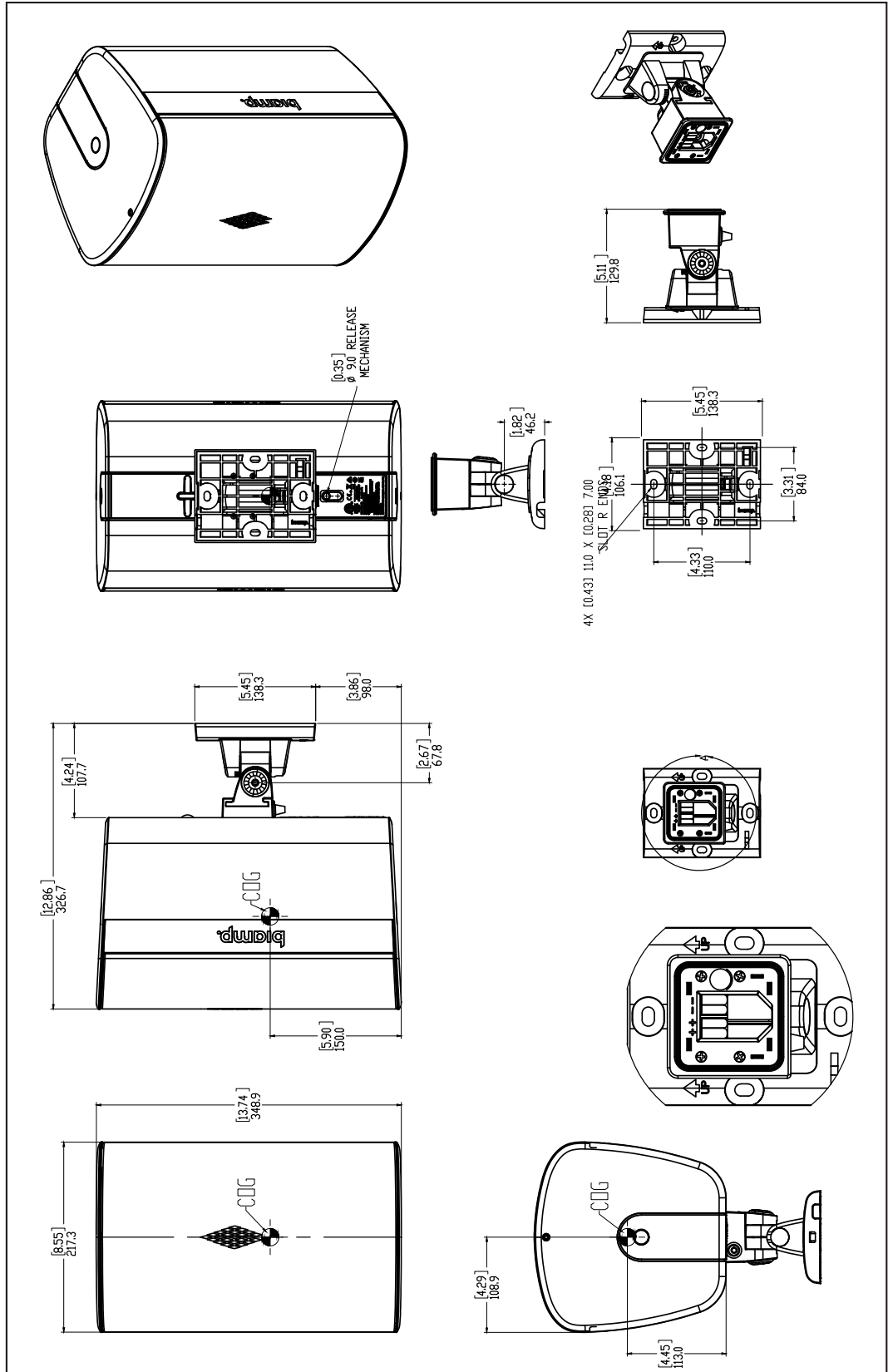

DESONO

EX-S6

TWO-WAY COAXIAL 6.5-INCH
SURFACE MOUNT LOUDSPEAKER

TECHNICAL DRAWING / DIMENSIONS / FINISH [EX-S6-UB]

H x W x D (loudspeaker)
365 x 217 x 253 mm
[14.37" x 8.55" x 9.96"] (including U-bracket)

Unit Weight

6.5 kg [14.4] lbs loudspeaker only
7.0 kg [15.5 lbs] loudspeaker + bracket

Shipping Weight
8.46 kg [18.7 lbs]

Grille and U-Bracket

Powder-coated Marine Grade aluminum. Grille is perforated and backed with hydrophobic cloth
Black (RAL 9017) or White (RAL 9016)

Enclosure / Finish

High-impact UL94 5VB rated polycarbonate/ABS blend, painted
UV resistant matte finish
Black (RAL 9017) or White (RAL 9016)

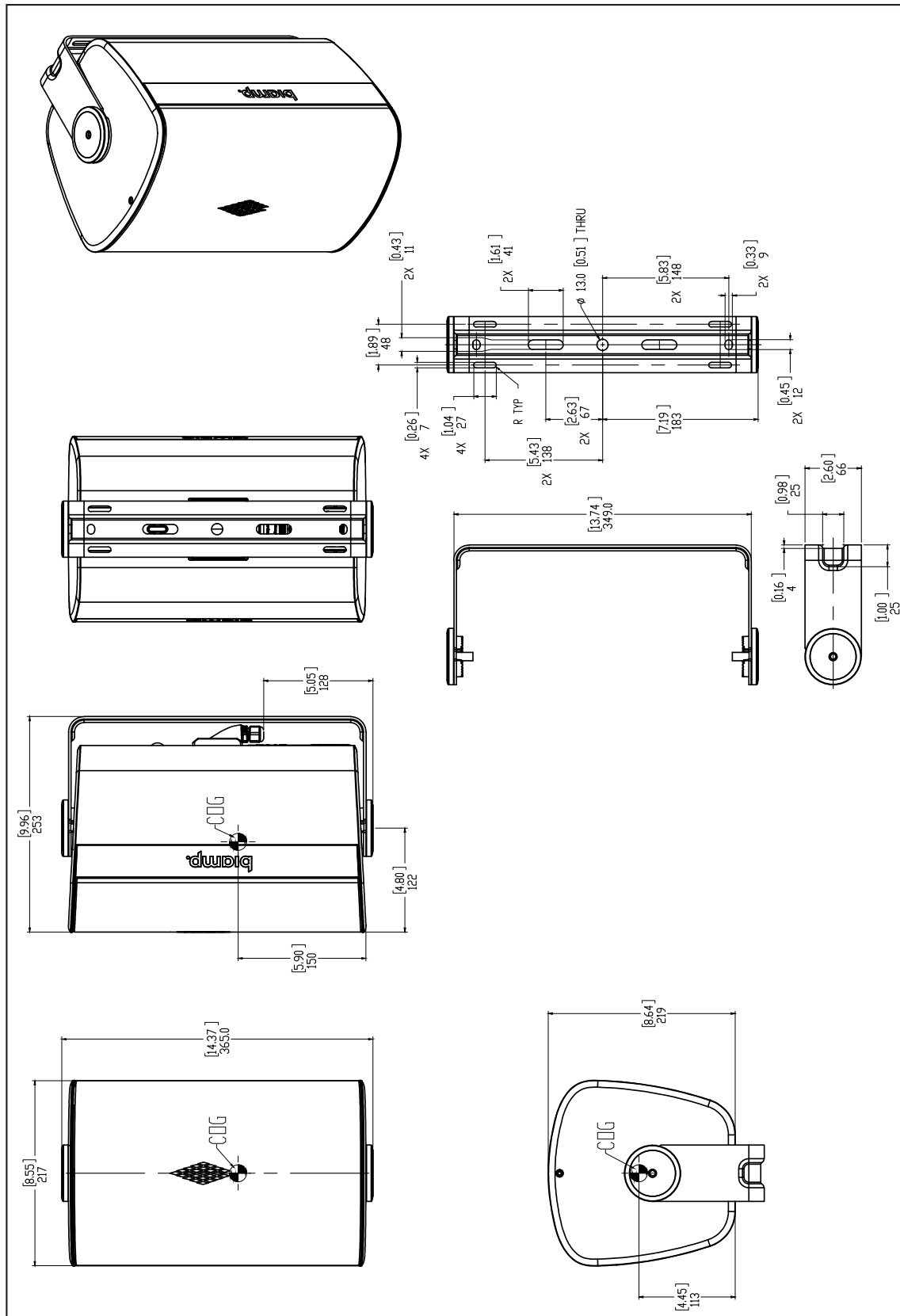

DESONO

EX-S6

TWO-WAY COAXIAL 6.5-INCH
SURFACE MOUNT LOUDSPEAKER

EX-S6-CM

EX-S6 Loudspeaker with ClickMount pan-tilt bracket

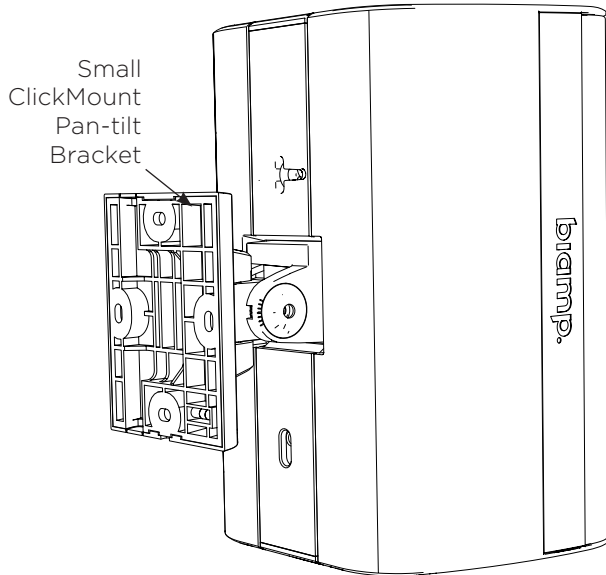

Pivot angle (portrait orientation)
Horizontal 120° in 10° increments
Vertical 56° in 8° increments (32° down-tilt)

EX-S6-UB

EX-S6 Loudspeaker with ClickMount U-Bracket and ClickPlug

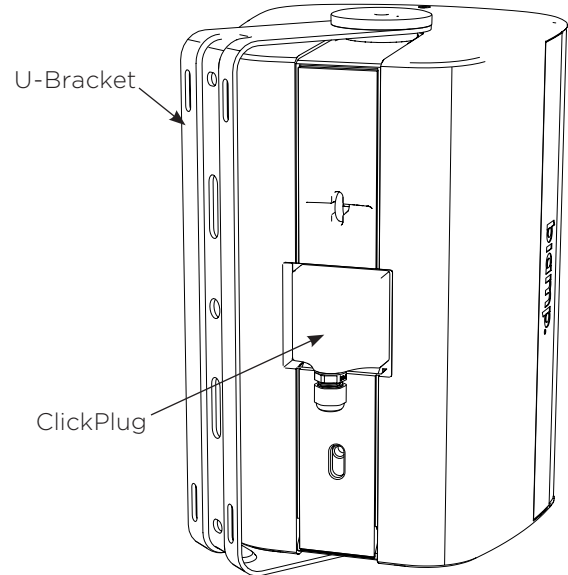

Pivot angle
200° in 10° increments

SPECIFICATIONS FOR EN54-24

Sensitivity (1 W, 4 m)	76.5dB	
Maximum SPL (4 m)	95.0dB (Low Z)	95.5 dB (80W tap)
Coverage (-6 dB) Horiz/Vert	500 Hz: 195°/165° 1 kHz: 160°/130°	2 kHz: 115°/115° 4 kHz: 95°/110°
Rated Impedance for Taps	Low Z: 7.5Ω; 80 W: 50Ω; 40 W: 100Ω; 20 W: 210Ω; 10 W: 430Ω	

AXES AND PLANES

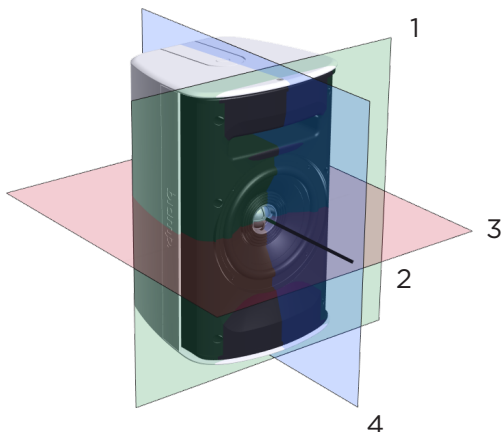

1. Reference Plane (green) is coincident with the front of the LF mounting ring
2. Reference Axis (black) perpendicular to the reference plane, passing through the center of the coaxial LF/HF driver
3. Horizontal Plane (red) intersects the reference plane and the vertical plane at a right angle and includes the reference axis
4. Vertical Plane (blue) intersects the reference plane at a right angle including the reference axis and the center point of the cabinet's front radius

Biamp strives to improve its products on a continual basis. Specifications are therefore subject to change without notice. Data presented on this data sheet represents the basic performance specifications for the model. For a detailed analysis of this loudspeaker's performance, please download the GLL file and/or the CLF file from our website: biamp.com

biamp.

A: 9300 S.W. Gemini Drive Beaverton, OR 97008 USA

T: +1 503.641.7287

W: www.biamp.com

DATA SHEET

DESONO™

EX-S6 TWO-WAY COAXIAL 6.5-INCH SURFACE MOUNT LOUDSPEAKER

CONNECTION DIAGRAMS

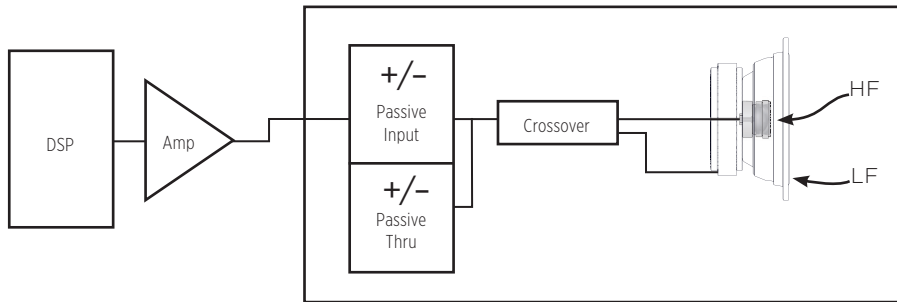

Single amp

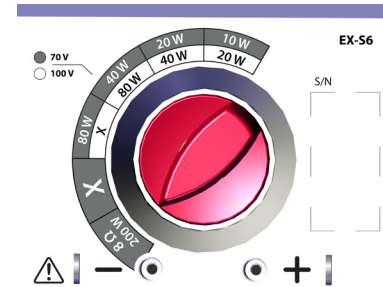

Tap Switch / Input Panel

NOTES

- 1. PERFORMANCE SPECIFICATIONS** All measurements are performed using a time-windowed impulse response to eliminate reflections, approximating an anechoic environment, at a distance of at least 6.0 m. All acoustic specifications are rounded to the nearest whole number. An external DSP using settings provided by Biamp is required to achieve the specified performance; further performance gains can be realized using the FIR loudspeaker optimization presets available in Biamp's Community Amplified Loudspeaker Controllers (ALC SERIES).
- 2. OPERATING RANGE** The frequency range over which the on-axis equalized/processed response remains within 10 dB of the rated sensitivity, in accordance with IEC 60268-5.
- 3. SENSITIVITY** The broadband SPL of the loudspeaker when pink noise is applied (band limited to the loudspeaker's Operating Range) at an input voltage of 2.83 V, in accordance with IEC 60268-5. Also listed for a voltage that would produce 1 watt into the nominal impedance. Measured in whole space with no external processing applied, except where indicated.
- 4. NOMINAL CONTINUOUS POWER HANDLING** The maximum continuous input voltage at the stated nominal impedance that the system can withstand, without damage, for a period of 2 hours using an IEC 60268-5 defined spectrum with recommended signal processing and protection filters.
- 5. NOMINAL MAXIMUM SPL** The SPL produced when an IEC 60268-5 signal is applied to the equalized/processed loudspeaker system, at a level which drives at least one subsection to its rated continuous voltage limit. Referenced to a distance of 1 meter. The peak SPL represents the 2:1 (6 dB) crest factor of the IEC 60268-5 test signal.
- 6. RATED CONTINUOUS VOLTAGE** The maximum continuous input voltage for the system that results in no more than a 3 dB change in the system's response during operation.
- 7. RATED MAXIMUM SPL** The SPL produced when a typical program material signal is applied to the equalized/processed loudspeaker system, at a level which drives at least one subsection to its rated continuous voltage limit. Referenced to a distance of 1 meter. The peak SPL represents the 4:1 (12 dB) crest factor of the program signal.
- 8. AXIAL (PROCESSED) SENSITIVITY** The variation in acoustic output level with frequency for a 2.83 V, swept-sine measurement signal. The Processed measurement uses the recommended signal processing for the loudspeaker system. The other sensitivity measurements use no additional external processing. All data are referenced to 1 meter. The on-axis magnitude and phase responses, as well as the average magnitude response, calculated over one-half of the nominal coverage angles, are shown. The responses have 1/6 octave smoothing applied.
- 9. HORIZONTAL / VERTICAL OFF-AXIS RESPONSES** The loudspeaker's magnitude response at various off-axis angles using the recommended signal processing in the operating mode which utilizes the largest number of individually amplified pass bands. The responses have 1/3 octave smoothing applied.
- 10. DIRECTIVITY INDEX** The ratio of the on-axis SPL to the mean SPL at the same distance for all points within the measurement sphere for each given frequency; expressed in dB. The responses have 1/3 octave smoothing applied.
- 11. BEAMWIDTH** The included angle between the -6 dB points in the polar response of the loudspeaker when driven in the operating mode which utilizes the largest number of individually amplified pass bands. The responses have 1/3 octave smoothing applied.

Data presented on this data sheet represents a selection of the basic performance specifications for the model. These specifications are intended to allow the user to perform a fair, straightforward evaluation and comparison with other loudspeaker spec sheets. For a detailed analysis of this loudspeaker's performance, please download the GLL file and/or the CLF file from our website: www.biamp.com

CAUTION: Installation of loudspeakers should only be performed by trained and qualified personnel. It is strongly recommended that a licensed and certified professional structural engineer approve the mounting design.