



3000 Series

Wireless In-Ear Monitor System

User Manual

Important information

The product is intended for commercial use, not for general use.

Warning:

To prevent fire or shock hazard, do not expose this apparatus to rain or moisture.

Caution:

- Do not expose this apparatus to drips or splashes.
- To avoid electric shock, do not open the cabinet.
- Refer servicing to qualified personnel only.
- Do not expose this apparatus to excessive heat such as sunshine, fire or the like.
- Do not subject this apparatus to strong impact.
- This apparatus should be located close enough to the AC outlet so that you can easily grasp the AC adapter at any time.
- In case of emergency, disconnect the AC adapter quickly.
- Do not place any objects filled with liquids, such as vases, on this apparatus.
- To prevent fire, do not place any naked flame sources (such as lighted candles) on this apparatus.
- Keep the product out of the reach of small children. The product is not intended for use around children.
- Do not place the product near fire to avoid an accident or the product catching fire.
- Do not install this apparatus in a confined space such as a bookcase or similar unit.
- Install this apparatus only in the place where ventilation is good.
- The rating label is put on the bottom of this apparatus.
- It is desirable that the transmitter should be installed and operated keeping it at least 20 cm or more away from person's body.

Battery caution:

- Keep batteries out of the reach of children.
- Observe correct polarity as marked.
- Do not expose the battery to excessive heat such as sunshine, fire or the like.
- Always consider the environmental issues and follow local regulations when disposing of batteries.
- Remove depleted battery immediately.
- Danger of explosion if battery is incorrectly replaced. Replace only with the same or equivalent type.
- Use only disposable LR06 (AA) alkaline or Ni-MH batteries.
- Do not use new and old batteries at the same time.
- Do not use different battery types or models.
- Do not use a leaking battery. If battery leakage occurs, avoid contact with skin. If contact occurs, immediately wash thoroughly with soap and water.
- If battery leakage comes into contact with your eyes, immediately flush with water and seek medical attention.

For customers in the USA

FCC Notice

Warning:

This device complies with Part 15 of the FCC Rules. Operation is subject to the following two conditions: (1) This device may not cause harmful interference, and (2) this device must accept any interference received, including interference that may cause undesired operation.

Caution:

You are cautioned that any changes or modifications not expressly approved in this manual could void your authority to operate this equipment. A license is required to use the frequency bands under FCC Part 74.

Note:

This equipment has been tested and found to comply with the limits for a Class B digital device, pursuant to part 15 of the FCC Rules. These limits are designed to provide reasonable protection against harmful interference in a residential installation. This equipment generates, uses and can radiate radio frequency energy and, if not installed and used in accordance with the instructions, may cause harmful interference to radio communications. However, there is no guarantee that interference will not occur in a particular installation. If this equipment does cause harmful interference to radio or television reception, which can be determined by turning the equipment off and on, the user is encouraged to try to correct the interference by one or more of the following measures:

- Reorient or relocate the receiving antenna.
- Increase the separation between the equipment and receiver.
- Connect the equipment into an outlet on a circuit different from that to which the receiver is connected.
- Consult the dealer or an experienced radio/TV technician for help.

This transmitter must not be co-located or operated in conjunction with any other antenna or transmitter used in other systems.

RF Exposure Statement

This device complies with FCC radiation exposure limits set forth for an uncontrolled environment and meets the FCC radio frequency (RF) Exposure Guidelines. This equipment has very low levels of RF energy that is deemed to comply without testing of specific absorption rate (SAR).

Contact:

Responsible Company: Audio-Technica U.S., Inc.
Address: 1221 Commerce Drive, Stow, Ohio 44224, USA
Tel: 330-686-2600

For customers in Canada

ISED statement

CAN RSS-Gen/CNR-Gen

This device contains license-exempt transmitter(s)/receiver(s) that comply with Innovation, Science and Economic Development Canada's license-exempt RSS(s). Operation is subject to the following two conditions:

1. This device may not cause interference.
2. This device must accept any interference, including interference that may cause undesired operation of the device.

This device complies with RSS-102 radiation exposure limits set forth for an uncontrolled environment.

Notes on use

- Be sure to read the user manual for any microphone or cable that you attach to the product.
- Unplug the AC adapter from the power outlet when not using the product.
- Turn off the power of this product before connecting or disconnecting cables.
- If you use the product near a TV or radio antenna, noise may be generated in the TV or radio. If this occurs, move the product away from the device.
- Two waves of the same frequency can't be used simultaneously.
- Be careful of interference noise caused by the surrounding radio wave environment and use of multiple systems.
- Wireless systems may be affected by the spark noise of vehicles, dimmer of lighting apparatus, computers, office automation apparatus and electronic musical instruments. Place and use the product where it is less likely to be affected by the above.
- Be sure to use the product in combination with components specified by Audio-Technica.
- Be sure to use a general-purpose LAN that complies with the Ethernet standard (CAT5e or higher, with shielding is recommended).
- Disconnect the LAN cable when not using the network.
- Be sure the connected cable is plugged all the way into the product.
- If you use the product close to an electronic or communications device (such as a mobile phone), the product may produce unwanted noise. If this occurs, move the product away from the device.
- When installing the product, ensure that there are no obstacles between the receiver and transmitter that may block the signal.
- To prevent depletion of the batteries/rechargeable batteries, turn off the receiver after use or when not in use.
- Over time, discoloration may occur due to ultraviolet rays (especially direct sunlight) and friction.
- It is legally prohibited to dismantle and modify this product. In addition, this product is so precisely manufactured that dismantling it could cause electric shock, failure, or fire. Never dismantle this product.

Using multiple wireless systems

- When using multiple units at the same time, use them in the same group and channel.
- When multiple units are used simultaneously, the receiver and transmitter should be at least 3 m (9.8') apart.
- When using multiple units, turn on receivers one by one, making sure there is no unwanted noise.

About Hearing Damage

WARNING!



USE AS LOW A VOLUME AS POSSIBLE. PERMANENT HEARING DAMAGE CAN RESULT FROM USING THIS SYSTEM AT EXCESSIVE VOLUMES.

For safe operation of this in-ear monitor system, do not listen at excessive sound pressure levels.

Most national safety and health administrations have established guidelines for maximum time being exposed to sound pressure levels before hearing damage occurs.

Sound pressure levels (SPL)	Maximum time being exposed
85 dB (A) SPL	8 hours
88 dB (A) SPL	4 hours
91 dB (A) SPL	2 hours
94 dB (A) SPL	1 hour
97 dB (A) SPL	30 minutes
100 dB (A) SPL	15 minutes
120 dB (A) SPL	avoid or hearing damage may occur

In live settings it is difficult to make exact measurements of sound pressure levels (SPL) present at the eardrum, which is affected not only by the in-ear monitor volume, but by ambient sound on the stage and other factors.

To protect your ears from hearing damage:

- Use the in-ear monitor system at the lowest volume possible; turn up the volume only enough to hear.
- Be aware that ringing in your ears may indicate that the volume is set too high.
- Have your ears examined regularly by an audiologist.
- If wax builds up in your ears, stop using the in-ear monitor system until you have seen an audiologist.
- To avoid infections, use an antiseptic to wipe the earphones before and after using the system.
- Stop using the earphones if you experience ear discomfort or infection.

Maintenance

- If the product becomes stained or covered with dust, be sure to disconnect the power plug before wiping it off with a dry and soft cloth.
- Do not use benzene, thinner, or electrical contact cleaner, etc. Doing so may cause deformation, damage, or malfunction.

About this system

This system (3000 Series Wireless In-Ear Monitor System) is designed to provide professional sound quality and functionality for all levels of live performance. It creates an optimal in-ear monitoring environment for live performance venue owners, system integrators, and performing musicians. A rack-mounted transmitter with front panel controls and large OLED display, a body-pack receiver with efficient headphone amplifier, and the ATH-E40 professional in-ear monitor headphones that create a balanced monitoring environment, are included in the package. These elements combine to provide clear, natural sound quality at every stage. Additional features include network monitoring and control via dedicated "Wireless Manager" software, and a cue mode that allows audio engineers to monitor multiple channels with a single receiver.

Part names and functions

ATW-T3205 (Stereo Transmitter)

Front panel

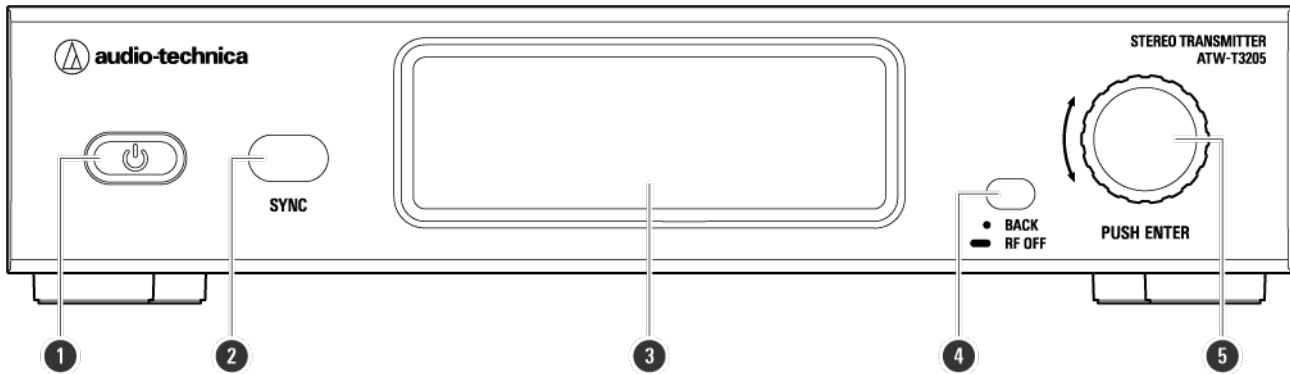

1 Power button

Turns transmitter on or off.

2 IR sync window

Used for IR SYNC with receiver.

3 Display

Displays the transmitter status and settings.

4 BACK button

Press to take the display back one screen.

Press and hold (about 2 seconds) on the main screen to toggle RF OFF (turning on while pressing and holding the BACK button will start the transmitter in RF OFF mode).

Press and hold on the menu screen to return to the main screen.

5 Control dial

Press to display the setting menu. Turn the control dial to select a setting item and press to confirm.

Press and hold (about 2 seconds) to display the "RX SYNC" screen.

Rear panel

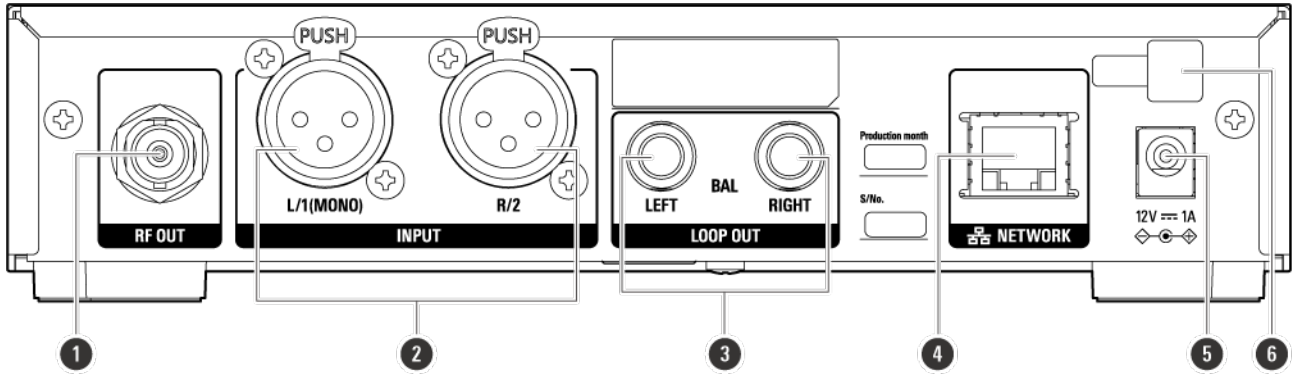

1 RF output jack

Connect the included flexible UHF antenna.

2 Balanced input jack (XLR 3-pin male)

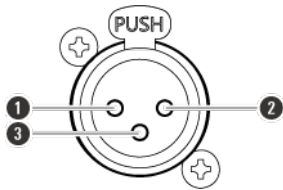

1 GND

2 HOT

3 COLD

3 Balanced output jack (6.3 mm (1/4") TRS female)

4 Network interface

By connecting to a PC via Ethernet, you can use the PC for monitoring and control.
LAN: 100Base-TX

5 Power input jack

Connect the AC adapter.

6 AC adapter cord hook

Hang the power cord of the AC adapter to prevent it from pulling loose accidentally.

ATW-R3250 (Stereo Receiver)

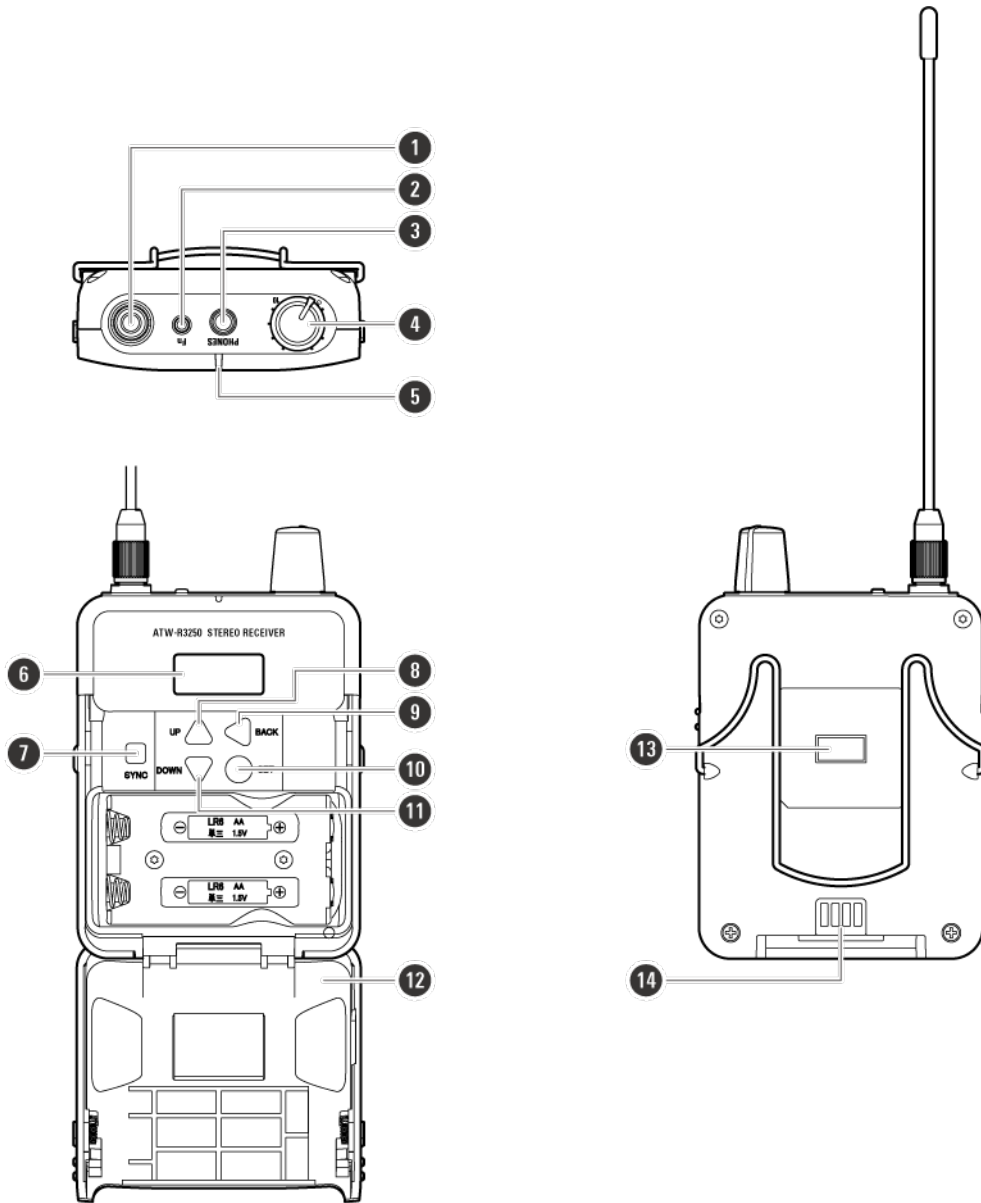

❶ Receiving antenna

❷ Function button

Press to turn the screen back on if it shuts off.
Press when the screen is lit to enter the audio setup screen.

❸ 3.5 mm (1/8") headphone output jack

❹ ON/OFF volume knob

Turns the power on or off.
Turn the knob to adjust the volume.

5 Indicator

LED that shows the status of the receiver.

When unmuted: Solid green

When muted: Solid red

6 Display

Shows the current status. If no buttons are pressed for a period of 30 seconds, the display will turn off.

7 SYNC button

Use to IR SYNC with the transmitter.

8 UP button

Use to select various settings.

9 BACK button

Press to take the display back one screen. Press and hold to return to the main screen.

10 SET button

Press to display the settings screen. Select the setting item and press to confirm the selection.

11 DOWN button

Use to select various settings.

12 Battery cover

13 IR sync window

Use to IR SYNC with the transmitter.

14 Charging terminal

Note

- When using the ATW-CHG3 or ATW-CHG3N Two-Bay Charging Station (sold separately), the receiver can be charged.
-

ATH-E40 (Dynamic In-Ear Headphones)

Also read the ATH-E40 user manual before use.

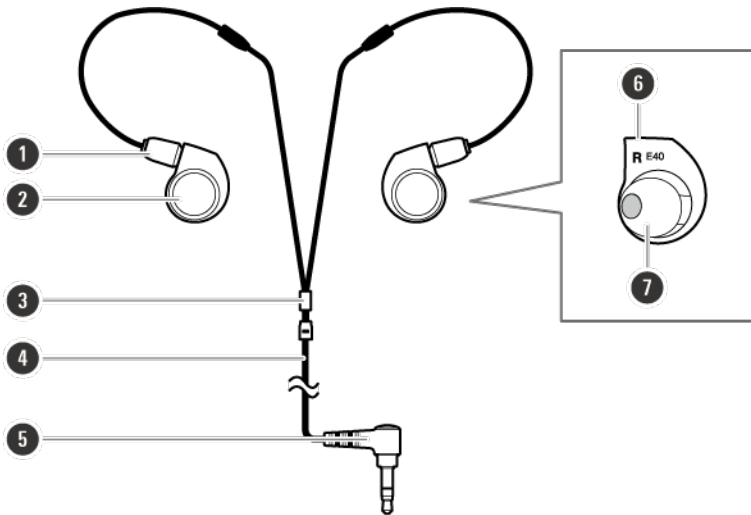

- ❶ A2DC connector plug
- ❷ Housing
- ❸ Cable adjustment slider
- ❹ 1.6 m (5.2') detachable cable
- ❺ Input plug (3.5 mm (1/8") gold-plated stereo mini-plug (L-shaped))
- ❻ LEFT/RIGHT (L/R) indicator
- ❼ Eartip

Replacing the detachable cable

The cable on the ATH-E40 is detachable. If there are signs of deterioration, replace the cable (sold separately). Do not detach the cable except when replacing it with a new cable.

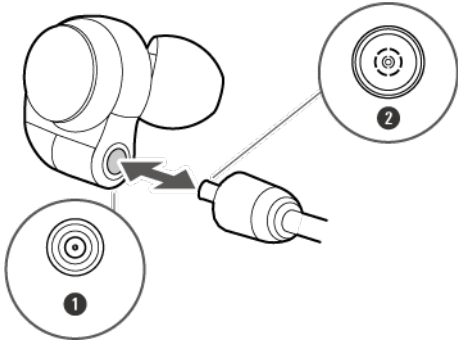

- ❶ Headphone
- ❷ Cable

How to detach the cable

Hold the connector and pull straight out in the direction shown by the arrow.

How to attach the cable

Plug the left or right connector in as shown in the figure until it clicks.

Caution

- The detachable connector is very delicate. Pulling at an angle or mounting at an angle will cause the pins to bend, resulting in malfunction. Only pull or attach in a straight motion to prevent malfunction.

Wearing the headphones

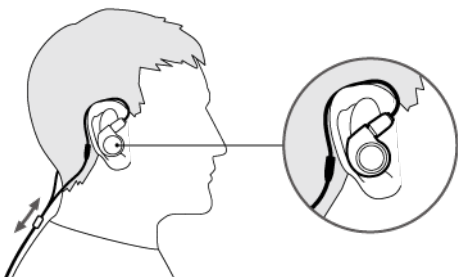

- 1 Wear the headphones with the "L" (left) marked on the left ear and the "R" (right) marked on the right ear and adjust the eartips.
- 2 Adjust the cable length with the cable adjustment slider.

System configuration examples

Basic connection example

The mixer mixes the sound of vocals, guitars, and other instruments, transmits that sound from the transmitter to the receiver, and monitors it through headphones from the receiver.

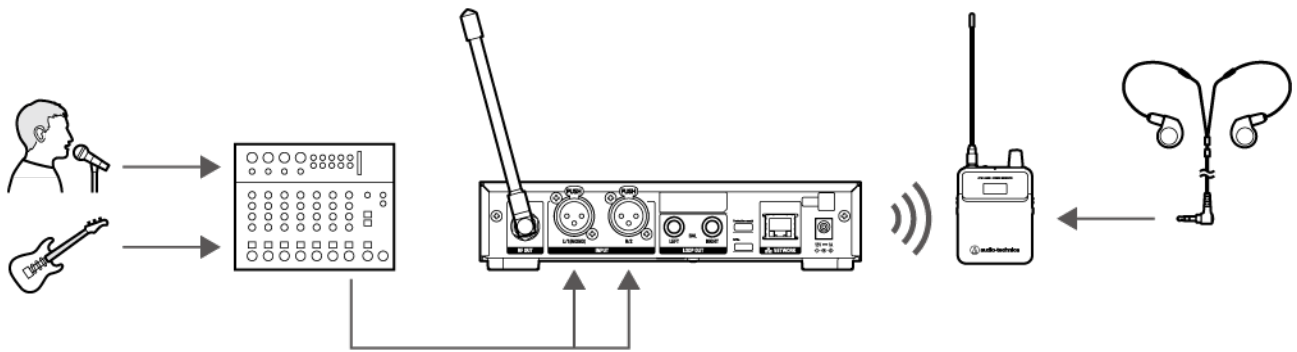

Loop out connection example (1)

Use the loop out to send the band mix from the mixer and individual vocals, guitars, and other instrument sounds from the transmitter to the receiver, mix them at the receiver, and monitor them through headphones. The band mix is shared to all transmitters using the loop out, with individual sound and mix balance adjustments.

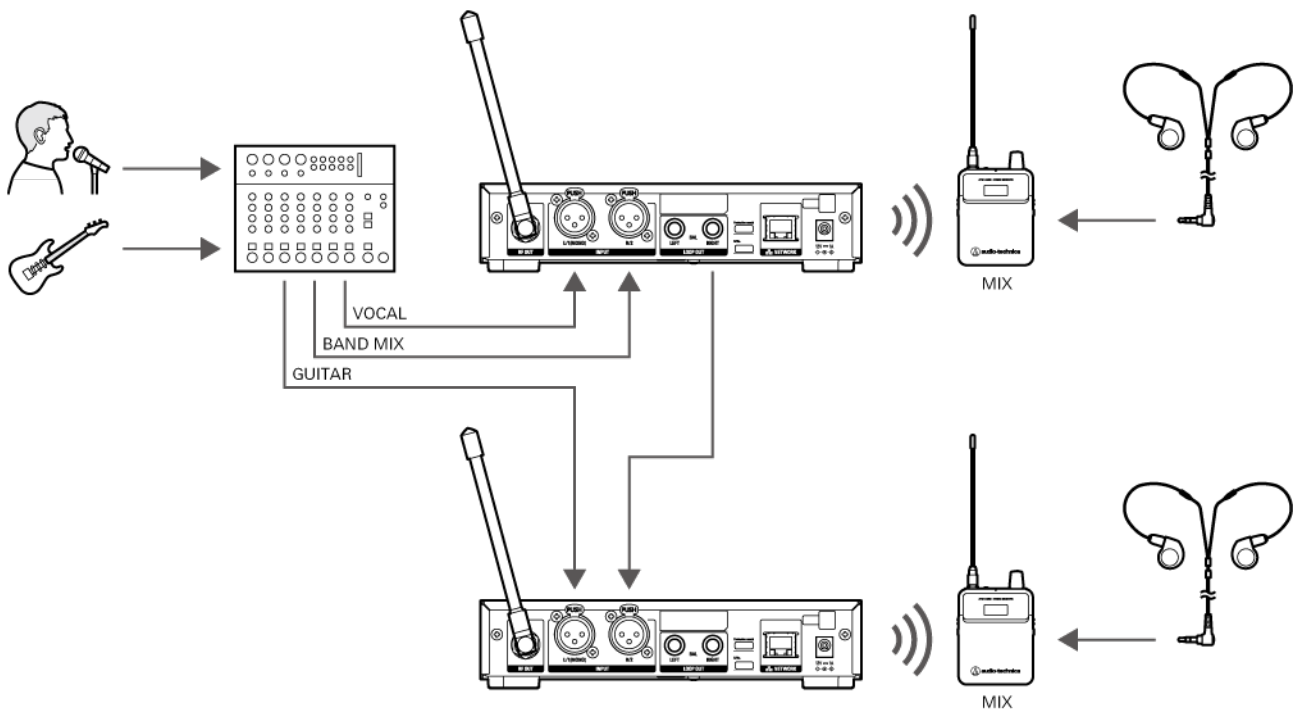

Loop out connection example (2)

Use the loop out to output the sound input to the transmitter to an external connected device (recorder, speakers, etc.). You can record simultaneously with your performance or output to floor speakers.

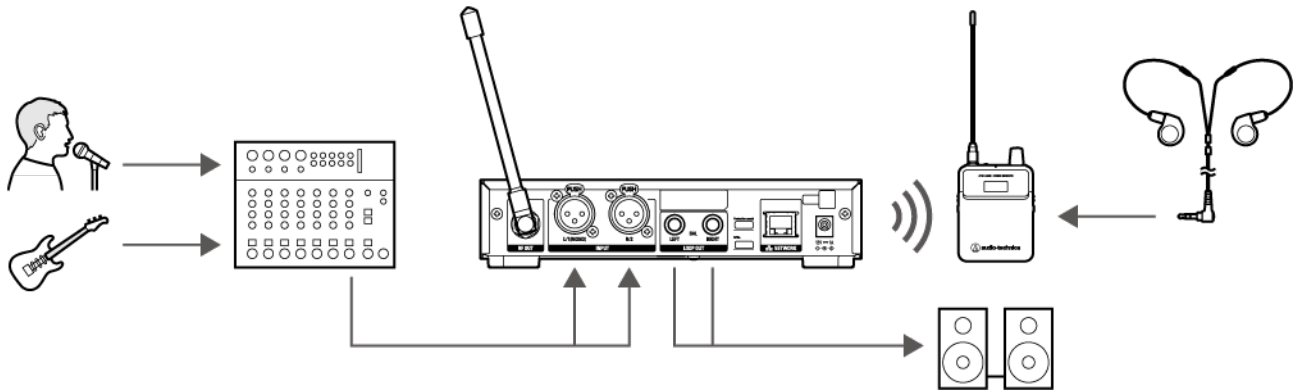

Rack-mounting (ATW-T3205)

- Screws for rack-mounting the transmitter are not included.
- Consider ventilation when rack-mounting to avoid heat building up in the rack.

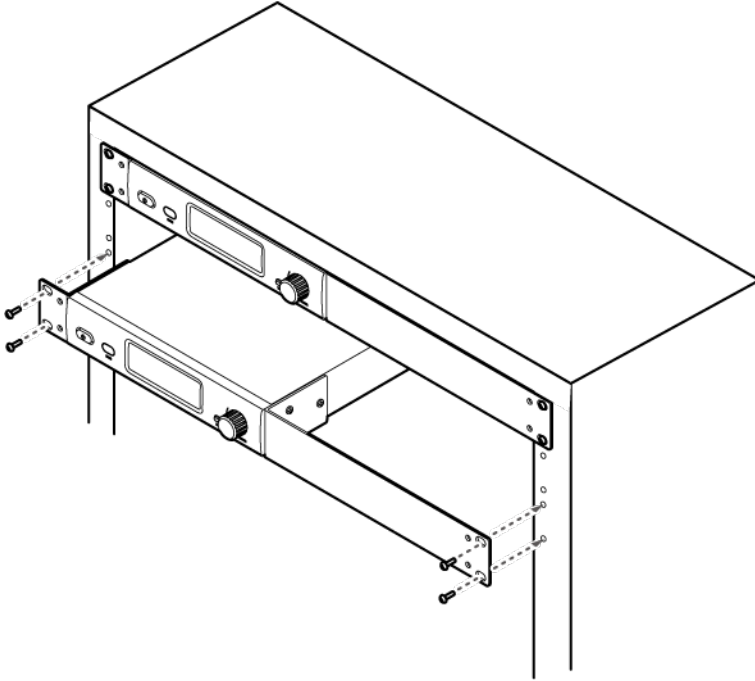

Using the belt clip (ATW-R3250)

The ATW-R3250 is equipped with a belt clip, so it can be attached to a belt, etc.

Belt clip orientation

The belt clip can be attached in the opposite direction.

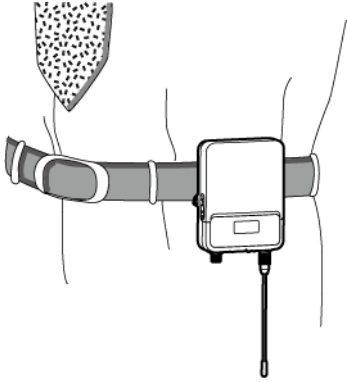

How to remove the belt clip

To remove the belt clip from the receiver, pull both sides of the belt clip strongly outward.

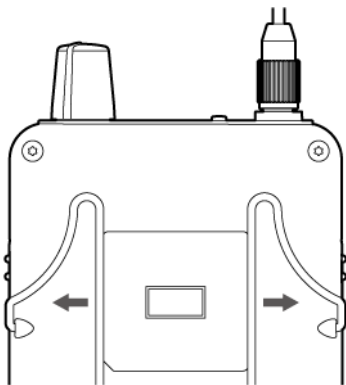

Inserting batteries (ATW-R3250)

- 1 Slide the battery cover latches down.

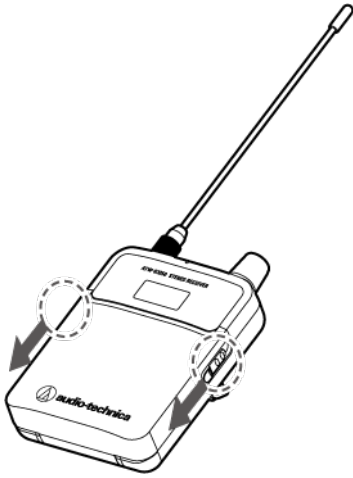

- 2 Open the battery cover while holding the latches down.

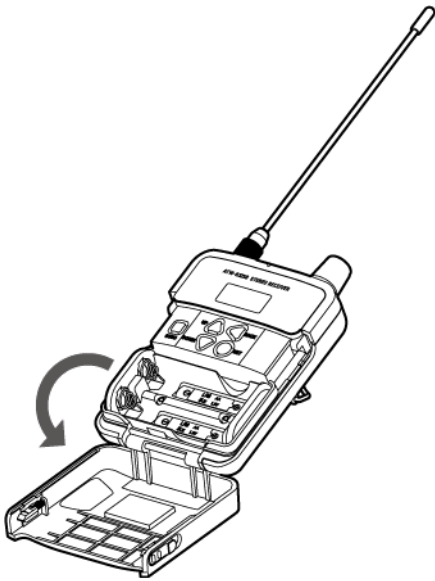

- 3** Insert the batteries according to the plus (+) and minus (-) marks found inside the battery compartment.

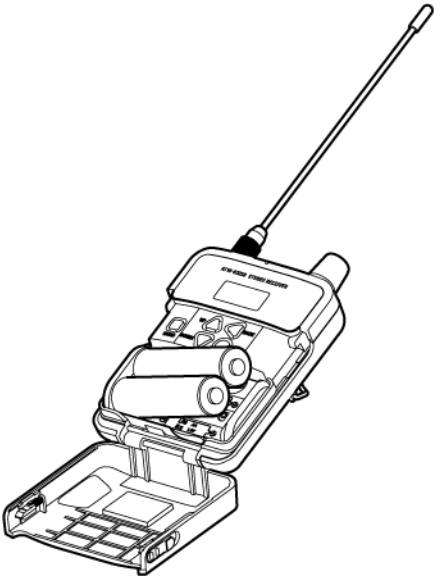

How to read the display

ATW-T3205

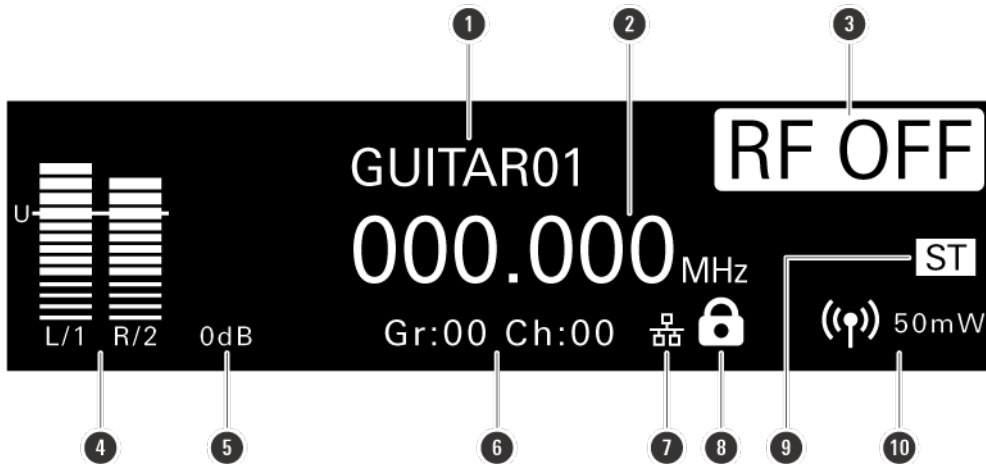

1 Name display

Displays the specified name.

2 Frequency indicator

Displays the specified frequency.

3 RF OFF indicator

Indicates when the RF output is turned off.

4 AF level indicator

Displays the level of the audio signal output from the transmitter to the receiver.
When Mode is set to "Mono" or "3000Link", only L/1 is displayed.
For AF peak, "!" mark will appear.

5 Audio input level indicator

6 Group and channel display

7 Network display

Icon is displayed when the transmitter is connected to a network.

8 Lock status display

9 RF mode display

ST: Stereo

MO: Mono

3KL: 3000Link

10 RF power display

ATW-R3250

Main screen

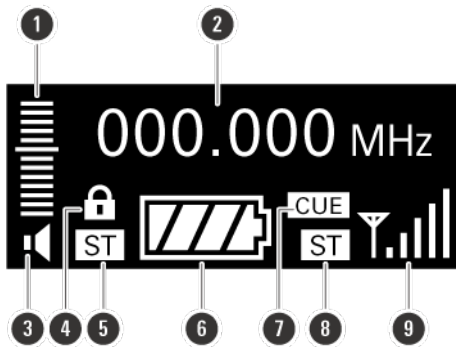

1 AF level indicator

Displays the level of the audio signal received by the receiver.
For AF peak, "!" mark will appear.

2 Frequency display

Displays the specified frequency.

3 Mute display

4 Lock status display

5 AF mode display

ST: Stereo

MX: Mix

MB: Mono/Balance

6 Battery level display

The level indicator of the icon changes depending on the remaining battery level.

Four: At least 75% battery power remaining.

Three: 50-75% battery power remaining

Two: 25-50% battery power remaining.

One: Battery level is below 25%.

One (flashing): Battery power is low.

0: Replace/recharge batteries.

7 Cue mode display

8 RF mode display

ST: Stereo

MO: Mono

3KL: 3000Link

9 RF level indicator

Displays the reception status.

Level meter display

This screen displays details of the RF meter and AF meter. User can use this to check detailed signal levels before playing, etc.

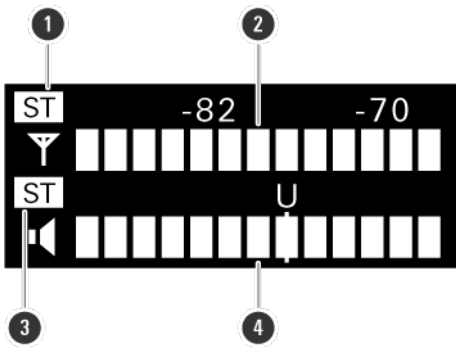

❶ RF mode display

ST: Stereo

MO: Mono

3KL: 3000Link

❷ RF level indicator

Displays the reception status.

❸ AF mode display

ST: Stereo

MX: Mix

MB: Mono/Balance

❹ AF level indicator

Displays the level of the audio signal received by the receiver.

For AF peak, "PEAK!" icon will appear.

Switching screen display

The main screen is displayed when the receiver is turned on. Pressing the UP/DOWN button on the main screen switches the screen display (Frequency display → Name display → Group and channel display → Level meter display).

Frequency display



Name display



Group and channel display



Level meter display

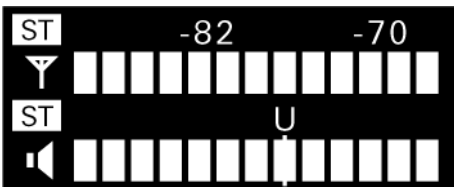

Network

By connecting a transmitter to a Windows PC/Mac, you can monitor and control the status of the transmitters and the receivers using a dedicated software, Wireless Manager.

What is Wireless Manager?

Wireless Manager is software that supports the setup, control, and monitoring of compatible Audio-Technica wireless devices. It allows the user to configure settings in the Device List tab, create an RF plan in the Frequency Coordination tab, and keep track of critical system levels and alerts in the Monitor tab. When linked to compatible wireless devices, you can scan the RF environment, monitor connected devices, and view the system log.

- Read the user manual for any device used with this software.
- Before using Wireless Manager, update network settings as described in “Configuring the network (NETWORK) (p.47) before use.

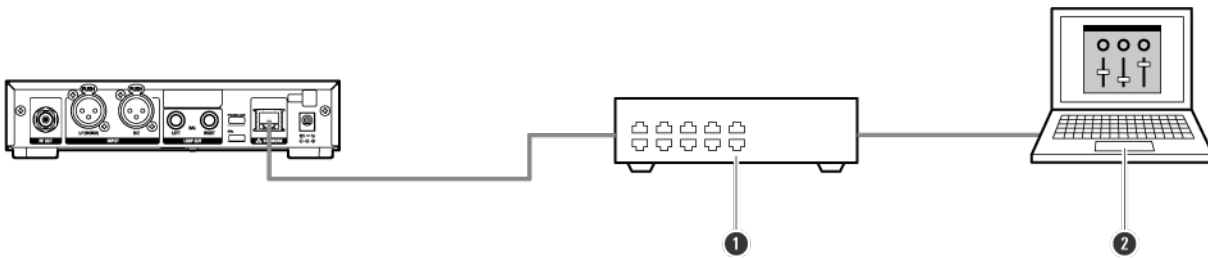

- ❶ Router
- ❷ Wireless Manager

Quick Start

Basic flow of using this system

- 1** Connect the included AC adapter to the transmitter and plug it into an outlet.
- 2** Attach the included antenna to the transmitter's RF output jack.
- 3** Connect a sound source such as a mixer output to the balanced input jack.
 - Both L/R balanced input jacks can be used.
 - For monaural sound sources, connect to the L/1 (Mono) balanced input jack.
- 4** Press the power button to turn the transmitter on.
 - The display lights and the main screen is displayed.

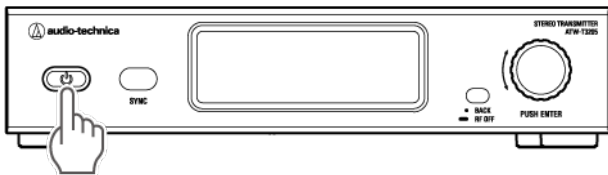

- 5** Set the transmission frequency.
 - The transmitter and receiver are set to the same frequency as the factory default.
 - RF scan can be performed on the receiver and the results synchronized via IR SYNC to the transmitter (p.31).
- 6** Turn the ON/OFF volume knob on the receiver to turn the power ON.
 - The indicator lights, and the display shows the main screen.

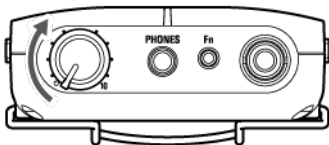

- 7** Set the operating frequency.
 - The transmitter and receiver are set to the same frequency as the factory default.
 - RF scan can be performed on the receiver and the results synchronized via IR SYNC with the transmitter (p.31).
- 8** Check the receiver's RF level indicator.
 - If the RF level indicator is displayed, the signal is being received.

9 Start playing.

- Check that the AF level indicators on the transmitter and receiver are moving.

10 Connect the headphones to the receiver and slowly turn up the volume.

- Before connecting headphones, the volume on the receiver should be minimized.

Note

- Press and hold the BACK button on the transmitter's main screen (about 2 seconds) to start the transmitter with the RF output turned off (RF OFF mode).

Useful functions

Performing RF scan

Use RF scan to analyze the surrounding radio environment and set the available frequencies. There are three types of scans.

Type of scan	Description
Group Scan	Scan the frequencies in the group to set the available frequency channels. This is useful when finding available channels in a user group.
Full Scan	Find all available frequencies in the available bands in 200 kHz steps. After synchronizing the scan results with the transmitter via IR SYNC, the scan results can be displayed on the transmitter and used for frequency coordination in a dedicated software (Wireless Manager).
Last Scan	The last scanned data is synchronized with the transmitter via IR SYNC. This is useful when you want to set the frequency again from previously scanned data.

Caution	<ul style="list-style-type: none">• When performing RF scan, the transmitter should be in RF OFF mode. It affects the results of the RF scan.• Wireless systems may be affected by the spark noise of vehicles, dimmer of lighting apparatus, computers, office automation apparatus and electronic musical instruments. When performing RF scan, turn these devices off.• When performing IR SYNC after RF scan, IR SYNC may not respond if the transmitter has just started up. In this case, perform IR SYNC again.
----------------	--

Performing a group scan

- 1** Press the SET button on the receiver's main screen.
- 2** Press the UP/DOWN button to select "SCAN" and press the SET button.
- 3** Select "Group Scan" and press the SET button.
- 4** Select "Group" or "Full Group" and press the SET button.

Item	Description
Group	Check the available frequencies in the selected group.
Full Group	Check the frequencies of all groups.

- 5** When "Group" is selected, select the group to be scanned and press the SET button.
 - When "Full Group" is selected, this step is not required.

- 6** Select the scan sensitivity from "Normal", "Low" or "High" and press the SET button.
» Scan starts. Please wait a moment.

- 7** When the scan result screen appears, check the screen.
 - The number of open channels available for the selected group is displayed. When you scan in "Full Group", you can check the open channels of all groups by pressing the UP/DOWN button.
 - When "Retry" is displayed, scan again.

- 8** Press the SYNC button and place the IR sync window of the receiver so it is facing the IR sync window of the transmitter.
 - Wait several seconds until communication is established.
» Once the transmitter and receiver are synchronized, the "RX SCAN DATA" screen will appear on the transmitter.

Caution

- IR SYNC cannot be performed correctly if the transmitter and receiver user group settings are different. If IR SYNC fails, check the user group settings.
-

Performing full scan

- 1** Press the SET button on the receiver's main screen.

- 2** Press the UP/DOWN button to select "SCAN" and press the SET button.

- 3** Select "Full Scan" and press the SET button.
» Scan starts. Please wait a moment.

- 4** When scanning is complete, press the SYNC button and place the IR sync window of the receiver so it is facing the IR sync window of the transmitter.
 - Wait several seconds until communication is established.
» Once the transmitter and receiver are synchronized, the "RX SCAN DATA" screen will appear on the transmitter.

Synchronizing the last scanned data to the transmitter

- 1** Press the SET button on the receiver's main screen.
 - 2** Press the UP/DOWN button to select "SCAN" and press the SET button.
 - 3** Select "Last Scan" and press the SET button.
 - 4** Press the SYNC button and place the IR sync window of the receiver so it is facing the IR sync window of the transmitter.
 - Wait several seconds until communication is established.
- » Once the transmitter and receiver are synchronized, the "RX SCAN DATA" screen will appear on the transmitter.

Performing IR SYNC

Settings made on the transmitter can be synchronized with the receiver via IR SYNC.

- 1** Press the control dial.
» The main menu screen appears.
- 2** Turn the control dial to select "RX SYNC" and press the control dial.
- 3** Turn the control dial to check the setting items to be synchronized with the receiver via IR SYNC.
- 4** Move the cursor to "SYNC START" and press the control dial.
» Transmitter is in standby for communication.
- 5** Press the SYNC button on the receiver and place the IR sync window of the receiver so it is facing the IR sync window of the transmitter.
 - Wait several seconds until communication is established.

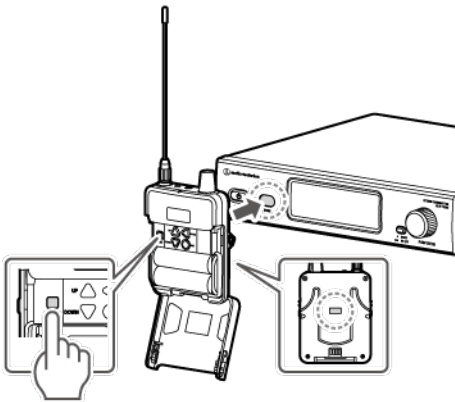

- 6** When synchronization of the transmitter and receiver is complete, the completion screen appears.
» Settings made on the transmitter are synchronized with the receiver.

Note

- If SYNC fails, an error screen is displayed and the screen is returned to the previous screen. Check the transmitter and receiver IR sync windows and perform IR SYNC again.
- To cancel IR SYNC, press the BACK button. The screen will be returned to the previous screen.

Caution

- IR SYNC cannot be performed correctly if the frequencies registered in the transmitter and receiver user groups are different. If IR SYNC fails, check the user group settings.

Using SYNC shortcut

A shortcut allows immediate access to the “RX SYNC” screen, which synchronizes the transmitter's settings with the receiver's.

- 1 Press and hold (for about 2 seconds) the control dial on the main screen.

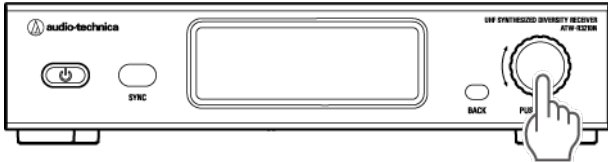

»» The “RX SYNC” screen appears.

Using the deploy function

Instead of setting the frequency of each transmitter one by one, this function allows you to use RX SCAN DATA to set the frequency of all transmitters in the same network at once. This is useful when using multiple units at the same time.

- 1** Set all transmitters to be used on the same network.
- 2** Press the control dial on the main screen.
- 3** Turn the control dial to select "FREQUENCY" and press the control dial.
- 4** Select "RX SCAN DATA" and press the control dial.
- 5** Select a group and press the control dial.
- 6** Select "DEPLOY" and press the control dial.
 - » Starts searching for transmitters on the same network.
- 7** After checking the search results, select "Yes" and press the control dial.
 - » The transmitter that performed the search is set to the lowest channel.
 - » The other transmitters are assigned to the channels in the group in descending order of IP address.
- 8** Other transmitter screens show a confirmation for changing settings. After confirming the contents, select "Yes" and press the control dial.
 - » The frequency settings of the transmitters are completed.

Note

- When a transmitter is displaying a screen other than the main screen while searching, this transmitter will not be searched.

Using the cue mode

Multiple frequencies can be saved as presets so that the receiver can switch between multiple frequencies. When operating multiple wireless systems, a single audio engineer can see audio being transmitted from multiple receivers while switching frequencies with a single receiver.

- Up to 10 presets can be registered.
- One preset contains information on frequency, name, group and channel, RF mode, AF mode, and balance.

Starting the cue mode

- 1** Press the SET button on the receiver's main screen.
 - 2** Press the UP/DOWN button to select "UTILITIES" and press the SET button.
 - 3** Press the UP/DOWN button to select "CUE MODE" and press the SET button.
- » The cue mode main screen appears.

Caution • Cue mode is not available in "3000Link" mode.

About the cue mode main screen

When the cue mode starts, you can switch between registered presets to check the audio.

When a preset is registered

The currently used preset is displayed.

Each time the function button is pressed or pressed and held, the preset can be switched.

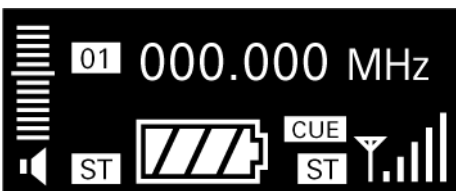

When no preset is registered

The screen for RX SYNC is displayed. Start registering a new preset.

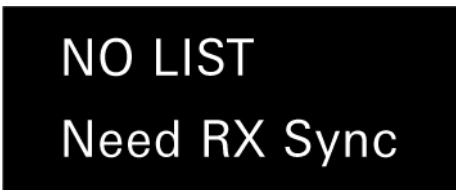

Adding a new preset

- 1** Press the SET button on the cue mode main screen.
» Receiver is in standby for communication.

- 2** Turn the transmitter's control dial to select "RX SYNC" and press the control dial.
 - Pressing and holding the control dial (about 2 seconds) will immediately display the "RX SYNC" screen.

- 3** Move the cursor to "SYNC START" and press the control dial.
 - Transmitter is in standby for communication.

- 4** Place the IR sync window of the receiver so it is facing the IR sync window of the transmitter
 - Wait several seconds until communication is established.» Once synchronization is complete, the preset is registered.

- 5** Repeat steps 1 through 4 to register the next preset.

Caution

- IR SYNC can't be performed if the transmitter's "MODE" is set to "3000 Link Mode". Change the setting.
-

Changing presets

- 1** Press the SET button on the cue mode main screen.
- 2** Press the UP/DOWN button to select "Edit" and press the SET button.
- 3** Select the preset you wish to change using the UP/DOWN button and press the SET button.
- 4** Press the SYNC button.
» Receiver is in standby for communication.
- 5** Turn the transmitter's control dial to select "RX SYNC" and press the control dial.
 - Pressing and holding the control dial (about 2 seconds) will immediately display the "RX SYNC" screen.
- 6** Move the cursor to "SYNC START" and press the control dial.
 - Transmitter is in standby for communication.
- 7** Place the IR sync window of the receiver so it is facing the IR sync window of the transmitter
 - Wait several seconds until communication is established.
» Once synchronization is complete, the preset is overwritten.

Deleting presets

- 1** Press the SET button on the cue mode main screen.
- 2** Press the UP/DOWN button to select "Delete" and press the SET button.
- 3** Select the preset you wish to delete using the UP/DOWN button and press the SET button.
» The preset is be deleted.

Deleting all presets

- 1** Press the SET button on the cue mode main screen.
- 2** Press the UP/DOWN button to select "Delete All" and press the SET button.
» The confirmation screen appears.
- 3** Press the UP/DOWN button to select "Yes" and press the SET button.
» All presets are deleted.

Exiting the cue mode

- 1** Press the SET button on the cue mode main screen.
- 2** Press the UP/DOWN button to select "Exit" and press the SET button.
» Receiver exits cue mode and returns to the main screen.

Setting ATW-T3205

Basic operation

- 1 Press the control dial.
» The main menu screen appears.

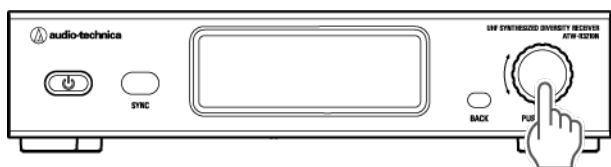

- 2 Turn the control dial to select the item you wish to set.



- 3 Press the control dial to open the settings menu of the selected item.
 - Press the BACK button to go back one screen.
 - To cancel partway through making a setting, press the BACK button.
 - While on the settings screen, the display will return to the main screen if about 30 seconds pass without a button or the control dial being used.

List of setting items

Item	Description
FREQUENCY	Set the transmission frequency.
NAME	Set the channel name.
SENSITIVITY	Set the audio input level.
MODE	Set the mode.
RF POWER	Set the RF power.
RX SYNC	Use IR SYNC to synchronize transmitter settings with the receiver.
UTILITIES	Set the system-related functions.
NETWORK	Set the network. Connecting the transmitter to a Windows PC/Mac allows status monitoring and control using a dedicated software (Wireless Manager).

Setting the transmit frequency (FREQUENCY)

Setting manually

- 1** From the menu screen, turn the control dial, select "FREQUENCY" and then press the control dial.
 - 2** Select "MANUAL" and press the control dial.
 - 3** Turn the control dial to set the first 3 digits. When finished setting them, press the control dial.
 - 4** Turn the control dial to set the last 3 digits. When finished setting them, press the control dial.
- » The setting is complete.

Setting by group/channel

- 1** From the menu screen, turn the control dial, select "FREQUENCY" and then press the control dial.
 - 2** Select "Gr/Ch" and press the control dial.
 - 3** Turn the control dial to set the group. When finished setting it, press the control dial.
 - 4** Turn the control dial to set the channel. When finished setting it, press the control dial.
- » The setting is complete.

Setting from RF scan results

After RF scanning at the receiver, frequency setting can be made from the scan data synchronized via IR SYNC. See "Performing RF scan" (p.28) for more information on RF scanning.

- 1** From the menu screen, turn the control dial, select "FREQUENCY" and then press the control dial.
 - 2** Select "RX SCAN DATA" and press the control dial.
 - 3** Select a group and press the control dial.
 - Select "FULL SCAN DATA" to show and confirm scan results in a graph.
 - Select "RESET" to delete the scan results.
 - 4** Select a channel and press the control dial.
 - When "DEPLOY" is selected, the frequency channel of the selected group are shared to transmitters in the same network, allowing you to change the settings of multiple units simultaneously at one time. For details, see "Using the deploy Function" (p.33).
- » The setting is complete.

Setting the channel name (NAME)

The number of characters that can be entered is 8. The characters that can be set are as follows:

- Alphabetic (uppercase letters)
- Numeric
- Symbols (L, +, -, #, &, period)
- Space

- 1** From the menu screen, turn the control dial to select "NAME" and press the control dial.
- 2** Turn the control dial, select the desired character, and then press the control dial.

» The character is input, and the cursor moves.
- 3** Repeat the operation in Step 2 to enter all characters.
- 4** Turn the control dial, select "End" and then press the control dial.

» The setting is complete.

Setting the audio input level (SENSITIVITY)

- 1** From the menu screen, turn the control dial to select "SENSITIVITY" and press the control dial.
 - 2** Turn the control dial to set the audio input level.
From -9 to 21 dB can be set.
 - 3** Press the control dial.
- » The setting is complete.

Setting the mode (MODE)

Set "Stereo Mode" / "Mono Mode" / "3000 Link Mode" according to the intended use.

Item	Description
Stereo Mode	Transmits stereo sound from the transmitter's balanced input jacks (L and R) and outputs a stereo signal to the receiver.
Mono Mode	Transmits only the sound from the transmitter's balanced input jack (L) and outputs a mono signal to the receiver.
3000 Link Mode	Signals from the transmitter can be received by a 3000 Series receiver (sold separately) other than this system, and can be connected to speakers, amplifiers, recorders, etc. from that 3000 Series receiver.

- 1** From the menu screen, turn the control dial to select "MODE" and press the control dial.
 - 2** Turn the control dial to select "Stereo Mode" / "Mono Mode" / "3000 Link Mode" and press the control dial.
- » The setting is complete.

Setting the RF power (RF POWER)

- 1 From the menu screen, turn the control dial to select “RF POWER” and press the control dial.
 - 2 Turn the control dial to select “Low:10mW” / “High:50mW” and press the control dial.
- » The setting is complete.

Note • Setting values vary depending on your country or region.

Checking and setting the items to be synchronized via IR SYNC (RX SYNC)

The settings made in this item can be synchronized with the receiver via IR SYNC.
The setting items and values are as follows:

Settings	Setting values
Freq	Current setting value, NoChange
Name	Current setting value, NoChange
RF Mode	Current setting value, NoChange
Audio Mode ^[1]	Stereo, Mix, Dual Mono, Mono Balance, NoChange
Balance	L1 to L15, L=R, R1 to R15, NoChange
Gain	-12dB, -6dB, 0dB, +6dB, NoChange
Low EQ	80Hz, 160Hz, 320Hz, Off, NoChange
High EQ	10kHz, 8kHz, 6kHz, Off, NoChange
Limiter	-30dB, -24dB, -18dB, -12dB, -6dB, Off, NoChange
Auto Lock	On, Off, NoChange
Batt.	Alkaline, Ni-MH, Lithium, NoChange

[1] The available setting values change depending on the RF Mode setting value.

- 1 From the menu screen, turn the control dial to select “RX SYNC” and press the control dial.
- 2 Turn the control dial to select a setting and press the control dial.
- 3 Turn the control dial to select the setting value and press the control dial.
- 4 Repeat Steps 2 and 3 for each setting.

- 5** Turn the control dial to select “SYNC START” and press the control dial.
 - Communication is in standby. Thereafter, see “Performing IR SYNC” (p.31).

Note

- This setting can also be displayed by pressing and holding (for about 2 seconds) the control dial on the main screen.

Setting the system-related functions (UTILITIES)

Item	Description
AUTO LOCK	Set the auto-lock function to automatically disable operation if no operation is performed for a certain period of time.
Gr/Ch EDIT	Edit channels for user groups (U1 to U6).
DISPLAY	Set items to be displayed prominently in the center of the main screen.
BRIGHTNESS	Set the display brightness.
CONTROL DIAL	Set the movement when the control dial is turned.
ACCESS	Set the user access level.
PRESET	Reset transmitter settings to user-specified settings or to factory defaults.
VERSION	Display information such as the version of the transmitter.

Setting the auto lock (AUTO LOCK)

Set the auto-lock function to automatically disable operation if no operation is performed for a certain period of time.

- 1** From the menu screen, turn the control dial, select “UTILITIES” and then press the control dial.
 - 2** Turn the control dial to select “AUTO LOCK” and press the control dial.
 - 3** Turn the control dial to select “On” or “Off” and press the control dial.
- » The setting is complete.

Unlocking the auto lock

When auto lock is turned on, the button operation will be disabled if nothing is done on the main screen for about 10 seconds. To unlock, press and hold the control dial (about 2 seconds), select “Unlock” and press the control button.

Editing group/channel (Gr/Ch EDIT)

Apart from the 18 preset groups, there are 6 user groups (U1-U6) where channels can be edited. In U1 to U6, you can edit up to 30 frequencies.

- All channels are empty in the initial state.

- 1** From the menu screen, turn the control dial, select "UTILITIES" and then press the control dial.
- 2** Turn the control dial, select "Gr/Ch EDIT" and then press the control dial.
- 3** Turn the control dial, select "EDIT" and then press the control dial.
- 4** Turn the control dial to select group and then press the control dial.
- 5** Turn the control dial, select a channel and then press the control dial.
- 6** Turn the control dial, select "SET" or "RESET" and then press the control dial.
 - By pressing "SET", you can set the frequency of the selected channel.
 - If you press "RESET", the frequency of the selected channel becomes empty.
- 7** After setting all channels, turn the control dial, select "Sync" or "Save" and then press the control dial.
 - If you press "Save", the setting is completed.
 - If you press "Sync", the screen turns to an IR SYNC standby screen. Thereafter, see "Performing IR SYNC" (p.31).

Syncing the Group/Channel

The group/channel set in "EDIT" can be synchronized with the receiver via IR SYNC for each group.

- 1** From the menu screen, turn the control dial, select "UTILITIES" and then press the control dial.
- 2** Turn the control dial, select "Gr/Ch EDIT" and then press the control dial.
- 3** Turn the control dial, select "Gr/Ch SYNC" and then press the control dial.
- 4** Turn the control dial to select group and then press the control dial.
 - The screen turns to an IR SYNC standby screen. Thereafter, see "Performing IR SYNC" (p.31).

Setting the main screen display (DISPLAY)

Set items to be displayed prominently in the center of the main screen.

- 1** From the menu screen, turn the control dial, select "UTILITIES" and then press the control dial.
 - 2** Turn the control dial to select "DISPLAY" and press the control dial.
 - 3** Turn the control dial to select "Frequency" / "Name" / "Gr/Ch" and press the control dial.
- » The setting is complete.

Setting the display brightness (BRIGHTNESS)

- 1** From the menu screen, turn the control dial, select "UTILITIES" and then press the control dial.
 - 2** Turn the control dial, select "BRIGHTNESS" and then press the control dial.
 - 3** Turn the control dial to select "High" or "Low" and press the control dial.
- » The setting is complete.

Setting the movement when the control dial is turned (CONTROL DIAL)

- 1** From the menu screen, turn the control dial, select "UTILITIES" and then press the control dial.
 - 2** Turn the control dial to select "CONTROL DIAL" and press the control dial.
 - 3** Turn the control dial to select "Default" or "Invert" and press the control dial.
- » The setting is complete.

Setting user access levels (ACCESS)

- 1 From the menu screen, turn the control dial, select "UTILITIES" and then press the control dial.
- 2 Turn the control dial, select "ACCESS" and then press the control dial.
- 3 Turn the control dial to select "Free Tuning" / "User Group Only" and press the control dial.

Item	Description
Free Tuning	No limit.
User Group Only	Frequency can be selected only from user groups.

» The setting is complete.

Restoring transmitter settings to user-specified settings / factory defaults (PRESET)

- 1 From the menu screen, turn the control dial, select "UTILITIES" and then press the control dial.
- 2 Turn the control dial to select "PRESET" and press the control dial.
- 3 Turn the control dial to select "Recall Preset" / "Save As Preset" / "Factory Reset" and press the control dial.

Item	Description
Recall Preset	Change to the settings saved as "SaveAsPreset". If "Recall Preset" is performed without saving the preset, it will return to the factory default settings.
Save As Preset	Saves the current transmitter settings as a preset.
Factory Reset	Reset transmitter settings to factory defaults. Saved presets are also returned to factory defaults.

- 4 Follow the on-screen instructions.
- » The setting is complete.

Checking the version of the transmitter (VERSION)

- 1 From the menu screen, turn the control dial, select "UTILITIES", and then press the control dial.
- 2 Turn the control dial to select "VERSION".

Configuring the network (NETWORK)

Connecting the transmitter to a PC allows monitoring and control via PC using a dedicated software (Wireless Manager).

Item	Description
DEVICE ID	Set the transmitter identification number.
IP SETTING	Set the IP address.
REMOTE CTRL	Set the remote control.
SYSLOG	Set whether to send the log message to the Syslog server.
DISCOVERY	Set automatic detection by the software.
NTP	Set the NTP (Network Time Protocol).
MAC ADDRESS	Display the MAC address.

Setting transmitter identification number (DEVICE ID)

- 1 From the menu screen, turn the control dial, select "NETWORK" and then press the control dial.
- 2 Turn the control dial, select "DEVICE ID" and then press the control dial.
- 3 Turn the control dial, select the device ID and then press the control dial.
 - » The Reboot confirmation screen appears.
- 4 Turn the control dial to select "Reboot" / "Later" and press the control dial.
 - » When "Reboot" is selected, the transmitter will reboot immediately to complete the setup.
 - » When "Later" is selected, the setup is complete temporarily. Be sure to reboot later. If you do not reboot, the network settings will not be completed.

Setting IP address (IP SETTING)

- 1 From the menu screen, turn the control dial, select "NETWORK" and then press the control dial.
- 2 Turn the control dial, select "IP SETTING" and then press the control dial.
- 3 Select an item you want to set and press the control dial.

Item	Description
IP Mode	Set how to obtain IP addresses. "Auto": Set up automatic IP address assignment. "Static": Set to use a static IP address.
IP Address ^[1]	Specify static IP addresses.
Subnet Mask ^[1]	Set the subnet mask.
Gateway ^[1]	Set the gateway.

[1] The available setting values change depending on the "RF Mode" setting value.

- 4 Set each item.
- 5 Press the BACK button.
 - » The Reboot confirmation screen appears.
- 6 Turn the control dial to select "Reboot" / "Later" and press the control dial.
 - » When "Reboot" is selected, the transmitter will reboot immediately to complete the setup.
 - » When "Later" is selected, the setup is complete temporarily. Be sure to reboot later. If you do not reboot, the network settings will not be completed.

Configuring settings related to remote control (REMOTE CTRL)

- 1 From the menu screen, turn the control dial, select "NETWORK" and then press the control dial.
- 2 Turn the control dial, select "REMOTE CTRL" and then press the control dial.
- 3 Select an item you wish to set and press the control dial.

Item	Description
Port	Set the IP port number.
Notification	Set to receive notifications from the transmitter during remote control.
LVL Notify ^[1]	Set whether to include AF and RF levels in notifications from the transmitter during remote control.
Multicast Port ^[1]	Set the port number for multicast.
Multicast IP ^[1]	Set the address for multicast.

[1] This can be set only when "Notification" is set to "ON".

- 4 Set each item.
- 5 Press the BACK button.
 - » The Reboot confirmation screen appears.
- 6 Turn the control dial to select "Reboot" / "Later" and press the control dial.
 - » When "Reboot" is selected, the transmitter will reboot immediately to complete the setup.
 - » When "Later" is selected, the setup is complete temporarily. Be sure to reboot later. If you do not reboot, the network settings will not be completed.

Configuring settings about log messages (SYSLOG)

Set whether to send the log message to the Syslog server.

- 1** From the menu screen, turn the control dial, select "NETWORK" and then press the control dial.
- 2** Turn the control dial, select "SYSLOG" and then press the control dial.
- 3** Turn the control dial to select "On" or "Off" and press the control dial.
» The Reboot confirmation screen appears.
- 4** Turn the control dial to select "Reboot" / "Later" and press the control dial.
» When "Reboot" is selected, the transmitter will reboot immediately to complete the setup.
» When "Later" is selected, the setup is complete temporarily. Be sure to reboot later. If you do not reboot, the network settings will not be completed.

Note

- Syslog is a standard for transferring log messages across IP networks. It is used for administration of computer systems and security monitoring.

Configuring settings for automatic detection from software (DISCOVERY)

- 1** From the menu screen, turn the control dial, select "NETWORK" and then press the control dial.
- 2** Turn the control dial, select "DISCOVERY" and then press the control dial.
- 3** Turn the control dial to select "On" or "Off" and press the control dial.
» The Reboot confirmation screen appears.
- 4** Turn the control dial to select "Reboot" / "Later" and press the control dial.
» When "Reboot" is selected, the transmitter will reboot immediately to complete the setup.
» When "Later" is selected, the setup is complete temporarily. Be sure to reboot later. If you do not reboot, the network settings will not be completed.

Configuring NTP settings (NTP)

- 1 From the menu screen, turn the control dial, select "NETWORK" and then press the control dial.
- 2 Turn the control dial, select "NTP" and then press the control dial.
- 3 Select an item you wish to set and press the control dial.

Item	Description
NTP	Set whether to enable or disable the NTP (Network Time Protocol).
Server Address ^[1]	Set the NTP server address.
Port ^[1]	Set the NTP port number.
Time Zone ^[1]	Set the time difference from the UTC (Coordinated Universal Time).
DST ^[1]	Turn on/off the daylight saving time.
Date ^{[1][2]}	Set the month and day for the start and end of daylight saving time.
Time ^{[1][2]}	Set the start and end time of daylight saving time.

[1] This can be set only when "NTP" is set to "ON".

[2] This can be set only when "DST" is set to "ON".

- 4 Set each item.
- 5 Press the BACK button.
 - » The Reboot confirmation screen appears.
- 6 Turn the control dial to select "Reboot" / "Later" and press the control dial.
 - » When "Reboot" is selected, the transmitter will reboot immediately to complete the setup.
 - » When "Later" is selected, the setup is complete temporarily. Be sure to reboot later. If you do not reboot, the network settings will not be completed.

Displaying MAC address (MAC ADDRESS)

- 1 From the menu screen, turn the control dial, select "NETWORK" and then press the control dial.
- 2 Turn the control dial to select "MAC ADDRESS".

Setting ATW-R3250

Basic operation

1 Press the SET button.

» The menu screen appears.

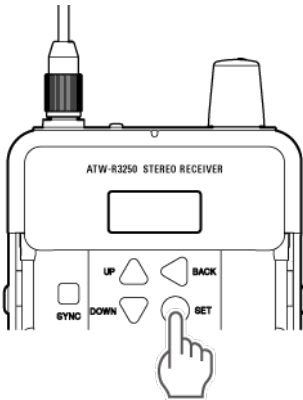

2 Press the UP/DOWN button to select the item you wish to set.

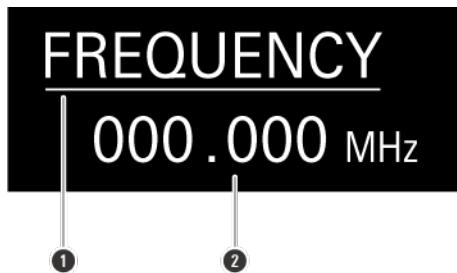

❶ Selected menu item

❷ Current setting

3 Press the SET button to display the settings screen for the selected item.

- Press the BACK button to go back one screen.
- To cancel partway through making a setting, press the BACK button.
- While on the settings screen, the display will return to the main screen if about 30 seconds pass without a button being used.

List of setting items

Item	Description
FREQUENCY	Set the operating frequency.
NAME	Set the channel name.
SCAN	Use RF scanning to analyze the surrounding radio environment and set the available frequencies.
SQUELCH	Set the squelch level.
AUDIO	Set the audio-related functions.
UTILITIES	Set the system-related functions.

Setting the receiving frequency (FREQUENCY)

Setting manually

- 1** From the menu screen, press the UP/DOWN button to select "FREQUENCY", and then press the SET button.
 - 2** After selecting "Manual", press the SET button.
 - 3** Press the UP/DOWN button to set the first 3 digits. After completing the setting, press the SET button.
 - 4** Press the UP/DOWN button to set the last 3 digits. After completing the setting, press the SET button.
- »» The setting is complete.

Setting by group/channel

- 1** From the menu screen, press the UP/DOWN button to select "FREQUENCY", and then press the SET button.
 - 2** Select "Gr/Ch" and press SET button.
 - 3** Press the UP/DOWN button to set the group. After completing the setting, press the SET button.
 - 4** Press the UP/DOWN button to set the channel. After completing the setting, press the SET button.
- »» The setting is complete.

Setting the channel name (NAME)

The number of characters that can be entered is 8. The characters that can be set are as follows:

- Alphabetic (uppercase letters)
- Numeric
- Symbols (┐, +, -, #, &, period)
- Space

- 1** From the menu screen, press the UP/DOWN button to select "NAME" and press the SET button.
 - 2** Press the UP/DOWN button to select a desired character and press the SET button.
- »» The character is input, and the cursor moves.
- 3** Repeat the operation in Step 2 to enter all characters.
 - If you don't enter 8 characters, press the UP/DOWN button and select "END" and then press the SET button.
 - 4** After entering the 8th character, press the SET button.
- »» "END" is displayed.
- 5** Press the SET button.
- »» The setting is complete.

Performing the RF scan (SCAN)

- 1 From the menu screen, press the UP/DOWN button to select "SCAN" and press the SET button.
- 2 Select "Group Scan" / "Full Scan" / "Last Scan" and press the SET button.
- 3 Follow the on-screen instructions.
 - See "Performing RF scan" (p.28) for more information.

Setting the squelch level (SQUELCH)

- 1 From the menu screen, press the UP/DOWN button to select "SQUELCH" and press the SET button.
 - 2 Select "Low" / "High" / "Mid" and press the SET button.
 - Selecting "Low" gives priority to the usable range.
 - Select "High" to give priority to voice quality.
- » The setting is complete.

Setting the audio-related functions (AUDIO)

Item	Description
AUDIO MODE	Set the mode of the output audio.
BALANCE	Adjust L/R sound panning or mix balance.
GAIN	Set the gain.
LOW EQ	Set the low-frequency sound quality of the audio.
HIGH EQ	Set the high-frequency sound quality of the audio.
LIMITER	Set the output level to headphones.

Note

- Pressing the function button on the main screen allows you to immediately check the status of audio-related settings. Press the SET button to display the "AUDIO MODE" screen for immediate settings.

Setting the audio mode (AUDIO MODE)

The modes that can be selected vary depending on the RF mode setting. The modes that can be selected are as follows.

When RF mode is set to "Stereo"

Item	Description
Stereo	The stereo input signal is output to L/R in stereo.
Mix	Mix the input signal in stereo and output the same audio in L and R.
Mono Bal	Mix the input signal in stereo and output balanced audio in monaural.

When RF mode is set to "Mono" / "3000Link"

Item	Description
Dual Mono	The signal input in monaural is output to L/R in monaural.
Mono Bal	The input signal in monaural is output balanced audio in monaural.

- 1 From the menu screen, press the UP/DOWN button to select "AUDIO" and press the SET button.
 - 2 Select "AUDIO MODE" and press the SET button.
 - 3 Select "Stereo" / "Dual Mono" / "Mono Bal" / "Mix" and press the SET button.
- » The setting is complete.

Adjusting L/R sound panning or mix balance. (BALANCE)

- 1 From the menu screen, press the UP/DOWN button to select "AUDIO" and press the SET button.
 - 2 Select "BALANCE" and press the SET button.
 - 3 Press the UP/DOWN button to adjust, then press the SET button.
 - When "AUDIO MODE" is set to "Stereo" or "Dual Mono", this function adjusts the L/R sound panning.
 - When "AUDIO MODE" is set to "MIX" or "Mono Bal", the L/R mix balance is adjusted.
- » The setting is complete.

Setting the gain (GAIN)

- 1** From the menu screen, press the UP/DOWN button to select "AUDIO" and press the SET button.
 - 2** Select "GAIN" and press the SET button.
 - 3** Press the UP/DOWN button to adjust, then press the SET button.
- »» The setting is complete.

Setting the audio low-frequency sound quality (LOW EQ)

The equalizer of this system is a shelving type.

- 1** From the menu screen, press the UP/DOWN button to select "AUDIO" and press the SET button.
 - 2** Select "LOW EQ" and press the SET button.
 - 3** Select "Off" / "80Hz" / "160Hz" / "320Hz" and press SET button.
- »» The setting is complete.

Setting the audio high-frequency sound (HIGH EQ)

The equalizer of this system is a shelving type.

- 1** From the menu screen, press the UP/DOWN button to select "AUDIO" and press the SET button.
 - 2** Select "HIGH EQ" and press the SET button.
 - 3** Select "Off" / "6kHz" / "8kHz" / "10kHz" and press the SET button.
- »» The setting is complete.

Setting the output level to headphones (LIMITER)

The factory default setting is “-30dB”.

- 1** From the menu screen, press the UP/DOWN button to select “AUDIO” and press the SET button.
 - 2** Select “LIMITER” and press the SET button.
 - 3** Select “-30dB”, “-24dB”, “-18 dB”, “-12 dB”, “-6 dB” or “Off” and press the SET button.
- » The setting is complete.

Configuring the system-related functions (UTILITIES)

Item	Description
AUTO LOCK	Set the auto-lock function to automatically disable operation if no operation is performed for a certain period of time.
RF MODE	Set the RF mode.
LVL LOCK	Lock the audio output level so that the volume cannot be adjusted.
CUE MODE	Use cue mode.
BATTERY	Set the type of batteries used.
LED	Set whether to constantly keep indicator turned on or off.
ACCESS	Set the user access level.
PRESET	Reset the receiver settings to user-specified settings or to factory defaults.
VERSION	Display the receiver version and other information.

Setting the auto lock (AUTO LOCK)

Set the auto-lock function to automatically disable operation if no operation is performed for a certain period of time.

- 1 From the menu screen, press the UP/DOWN button to select "UTILITIES", and then press the SET button.
 - 2 Select "AUTO LOCK" and press the SET button.
 - 3 Select "On" or "Off" and press the SET button.
- » The setting is complete.

Unlocking the auto lock

When auto lock is turned on, the button operation will be disabled if nothing is done on the main screen for about 10 seconds. To unlock, press the SET/SYNC button and the DOWN button. Select "Unlock" and press the SET button."

Setting the RF mode (RF MODE)

Set "Stereo" / "Mono" / "3000Link" according to the intended use.

Item	Description
Stereo	Received in stereo.
Mono	Received in mono.
3000Link	Used to receive signals from our separately sold 3000 Series transmitters.

- 1 From the menu screen, press the UP/DOWN button to select "UTILITIES", and then press the SET button.
 - 2 Select "RF MODE" and press the SET button.
 - 3 Select "Stereo" / "Mono" / "3000Link" and press the SET button.
- » The setting is complete.

Locking the audio output level (LVL LOCK)

Lock the audio output level so that the volume cannot be adjusted. This is useful when you want to use a fixed volume without adjusting it repeatedly.

- 1** From the menu screen, press the UP/DOWN button to select "UTILITIES", and then press the SET button.
 - 2** Select "LVL LOCK" and press the SET button.
 - 3** Select "On" and press the SET button.
 - Select "Off" to unlock.
 - 4** Turn the ON/OFF volume knob to the level at which you wish to fix the volume.
 - Values that can be set are from 2 to 10. It is linked to the ON/OFF volume knob.
 - 5** Press the SET button.
- » The setting is complete.

Using the cue mode (CUE MODE)

- 1 From the menu screen, press the UP/DOWN button to select "UTILITIES", and then press the SET button.
 - 2 Select "CUE MODE" and press the SET button.
- » Cue mode is initiated. See "Using the cue mode" (p.34) for details on subsequent steps.

Setting the type of battery to be used (BATTERY)

- 1 From the menu screen, press the UP/DOWN button to select "UTILITIES", and then press the SET button.
- 2 Select "BATTERY" and press the SET button.
- 3 Press the UP/DOWN button to select the battery you wish to set.

Item	Description
Alkaline	Select when using alkaline batteries.
Lithium	Select when using lithium batteries.
Ni-MH	Select when using nickel-metal hydride batteries.

- 4 Press the SET button.
- » The setting is complete.

Note

- If the appropriate setting is not made for the batteries used, the battery power indicator will not display the correct information. Always set the type of battery according to the batteries used.

Setting whether the indicator is always on (LED)

- 1 From the menu screen, press the UP/DOWN button to select "UTILITIES", and then press the SET button.
 - 2 Select "LED" and press the SET button.
 - 3 Select "On" or "Off" and press the SET button.
- » The setting is complete.

Setting the user access level (ACCESS)

- 1 From the menu screen, press the UP/DOWN button to select "UTILITIES", and then press the SET button.
- 2 Select "ACCESS" and press the SET button.
- 3 Select "Free" / "UserGroup" and press the SET button.

Item	Description
Free	No limit.
UserGroup ^[1]	Frequency can be selected only from user groups

[1] When set, the "Last Scan" data of RF scan and the presets registered in cue mode will be deleted.

» The setting is complete.

Restoring the receiver settings to user-specified settings / factory defaults (PRESET)

- 1 From the menu screen, press the UP/DOWN button to select "UTILITIES", and then press the SET button.
- 2 Select "PRESET" and press the SET button.
- 3 Select "RecallPreset" / "SaveAsPreset" / "FactoryReset" and press the SET button.

Item	Description
RecallPreset	Change to the settings saved as "SaveAsPreset". If "Recall Preset" is performed without saving the preset, it will return to the factory default settings.
SaveAsPreset	Save the current receiver settings as a preset.
FactoryReset	Reset receiver settings to factory defaults. Saved presets are also returned to factory defaults.

- 4 Follow the on-screen instructions.
- » The setting is complete.

Check the receiver version (VERSION)

- 1** From the menu screen, press the UP/DOWN button to select "UTILITIES", and then press the SET button.
- 2** Select "VERSION" and press the SET button.

Troubleshooting

ATW-T3205

? The power can't be turned on

- Check if the AC adapter is connected properly.

? There is no voice / The voice level is low

- Check to see if the transmitter and receiver are on the same channel.
- Make sure the power button on the transmitter is not turned off.
- Confirm that the antennas are correctly connected.
- Make sure that RF OFF mode is on.
- Check to make sure that the transmitter is not disconnected from an external device such as a mixer.
- Confirm that the audio output isn't set to the minimum level.
- Check that the audio output volume of the mixer or other external device connected to the transmitter is not too low.

? Sound is distorted

- Confirm that the audio output level isn't too high.
- Confirm that the volume of any external device isn't too high.

? There is unwanted noise

- Make sure there are no noise sources such as fluorescent lights or electrical equipment near the transmitter.
- Confirm that each transmitter is using a different frequency.
- Make sure that the transmitter and receiver antennas are not too close together.
- Check that the connections from the input/output jack of the transmitter are made properly.
- Make sure the transmitter is not powered from the same outlet as noisy equipment.
- Confirm that there isn't any other nearby wireless system using the same frequency band.

ATW-R3250

? The power can't be turned on

- Confirm that batteries are in place.
- Confirm that batteries are not depleted.
- Confirm that batteries are inserted in the right direction.

? There is no voice / The voice level is low

- Check to see if the transmitter and receiver are on the same channel.
- Check that the receiver's ON/OFF volume knob is not turned off.
- Confirm that the antennas are correctly connected.
- Confirm that the audio output isn't set to the minimum level.

? Sound is distorted

- Confirm that the audio output level isn't too high.
- Confirm that the volume of any external device isn't too high.
- Check to see if the receiver's gain setting is too high.

? There is unwanted noise

- Make sure there are no noise sources such as fluorescent lights or electrical equipment near the receiver.
- Confirm that each transmitter is using a different frequency.

? Low battery is displayed even though the battery was just replaced

- Check the battery settings.

Dimensions

ATW-T3205

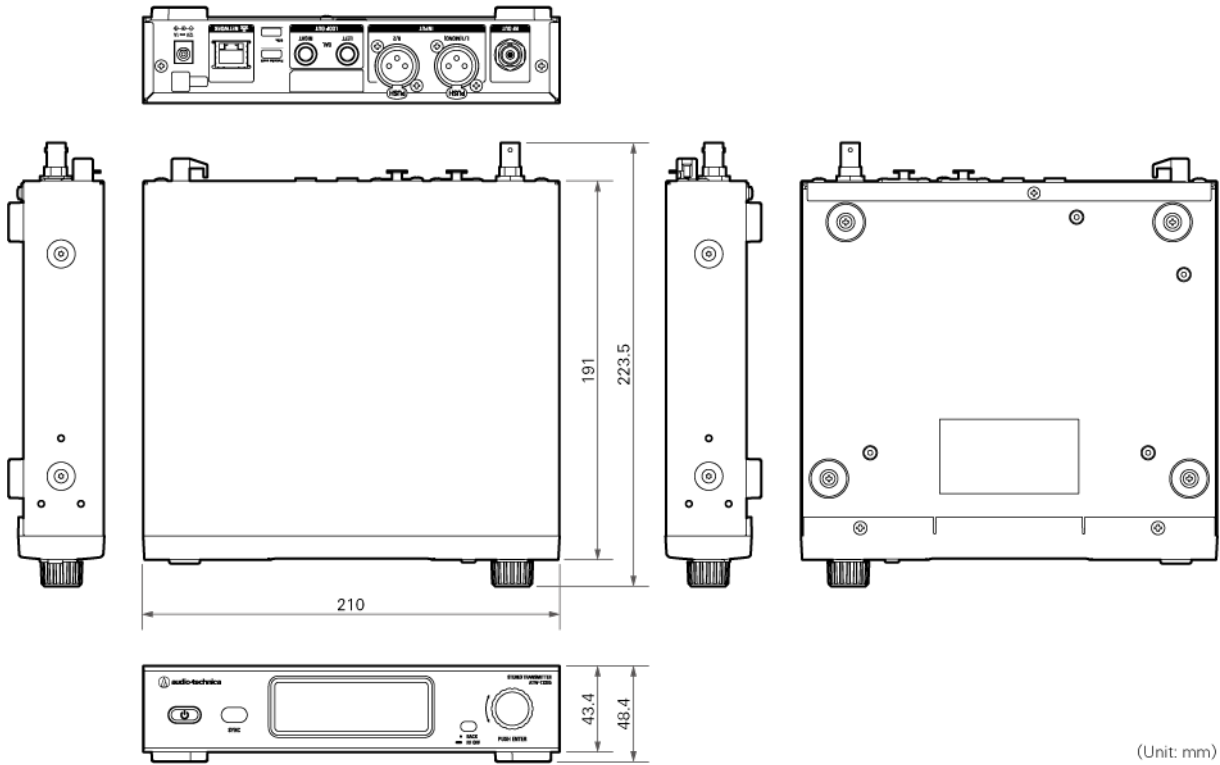

ATW-R3250

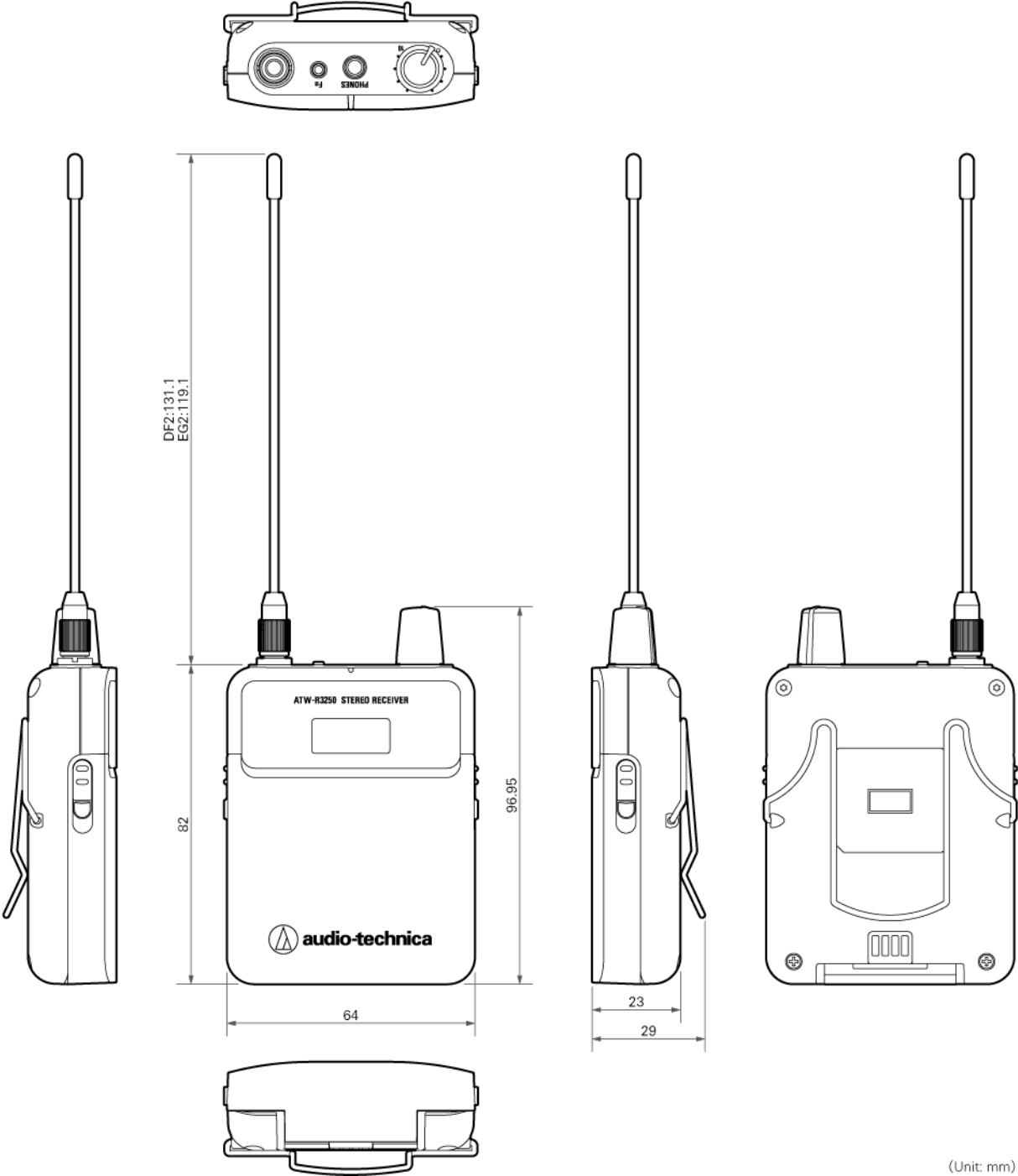

Specifications

Overall system specifications

Operating frequencies ^[1]	Band DF2: 470.125 to 607.875 MHz Band EG2: 580.000 to 713.850 MHz
Minimum frequency step	25 kHz
Modulation mode	FM
Nominal/Peak deviation	±34 kHz nominal / ±45 kHz peak
Dynamic range	>90 dB, A-weighted, typical
Total harmonic distortion	<0.2% (at 1 kHz, +4 dBu input)
Operating range ^[2]	90 m (300')
Frequency response	40 Hz to 14,100 Hz
Stereo separation	75 dB
Maximum simultaneous use (recommended) ^[3]	49 ch per band

[1] Please note that some frequency bands might not be available in your territory or could come with a limited tuning bandwidth / transmitting power due to local regulations.

[2] Open range environment with no interfering signals.

[3] For assistance with multi-band operation or other frequency coordination issues, contact your local audio-technica dealer.

ATW-T3205

RF output power ^[1]	High: 50 mW, Low: 10 mW (switchable) at 50 ohms
Input connection	XLR-F type×2 (Pin1: GND, Pin2: Hot, Pin3: Cold)
Maximum input level	XLR-F type: +24 dBu (at 0 dB sensitivity)
Output connection	6.3 mm (1/4") TRS×2 (Tip: Hot, Ring: Cold, Sleeve: Ground)
Network	100BASE-T
Network port	RJ-45
Power supply	100 to 240 V AC (50/60 Hz) to 12V DC 1 A (center positive) switched mode external power supply
Antenna output	BNC-type, 50 ohms
Dimensions	210 mm (8.3")×191 mm (7.5")×43.4 mm (1.7") (W×D×H)
Weight (without accessories)	1,100 g (39 oz)
Included accessories	AC adapter Rack-mount (large, small) Flexible UHF antenna

[1] May differ depending on the country or region in which you live.

ATW-R3250

Receiving system ^[1]	Antenna diversity
Image rejection	>80 dB, typical
RF sensitivity	20 dBuV at 60 dBA S/N ratio (50 ohms termination)
Headphone output jack	3.5 mm (1/8") TRS stereo mini-jack
Headphone output	40 mW (at 12 ohms)
EQ	Low: 80 Hz / 160 Hz / 320 Hz / ±9 dB in 3 dB step High: 6 kHz / 8 kHz / 10 kHz / ±9 dB in 3 dB step
Limiter	Selectable: -30 dB to OFF (0 dB) in 6 dB steps
Antenna input	SMA type, 50 ohms
Batteries	3 V DC (two 1.5 V AA) (not included)
Operating temperature range ^[2]	-5°C to +45°C (23°F to 113°F)
Battery life ^[3]	4 to 6 hours (alkaline) 5 to 7 hours (Ni-MH, 1900 mAh) 11 to 13 hours (lithium)
Dimensions	64 mm (2.5")×23 mm (0.91")×82 mm (3.2") (W×D×H)
Weight (without batteries)	102 g (3.6 oz)
Included accessories	ATH-E40

[1] Audio output cable performs as a secondary antenna to ensure stable RF performance.

[2] Battery performance may be reduced at very low temperatures.

[3] Depending on battery type, usage, volume level and environmental conditions.

- For product improvement, the product is subject to modification without notice.

株式会社オーディオテクニカ

〒194-8666 東京都町田市西成瀬2-46-1
www.audio-technica.co.jp

Audio-Technica Corporation

2-46-1 Nishi-naruse, Machida, Tokyo 194-8666, Japan
www.audio-technica.com
©2020 Audio-Technica Corporation
Global Support Contact: www.at-globalsupport.com