

Xone:24C User Guide

Issue 2

INTRODUCTION

Xone:24C is a compact 2+1 channel hybrid DJ mixer that blends analogue sound quality with flexible digital connectivity.

Building on the foundations of the all-analogue Xone:24, the Xone:24C adds a high-quality USB-C interface and powered USB hub for easy integration with DVS, streaming, and production setups.

PACKED ITEMS

Xone:24C mixer

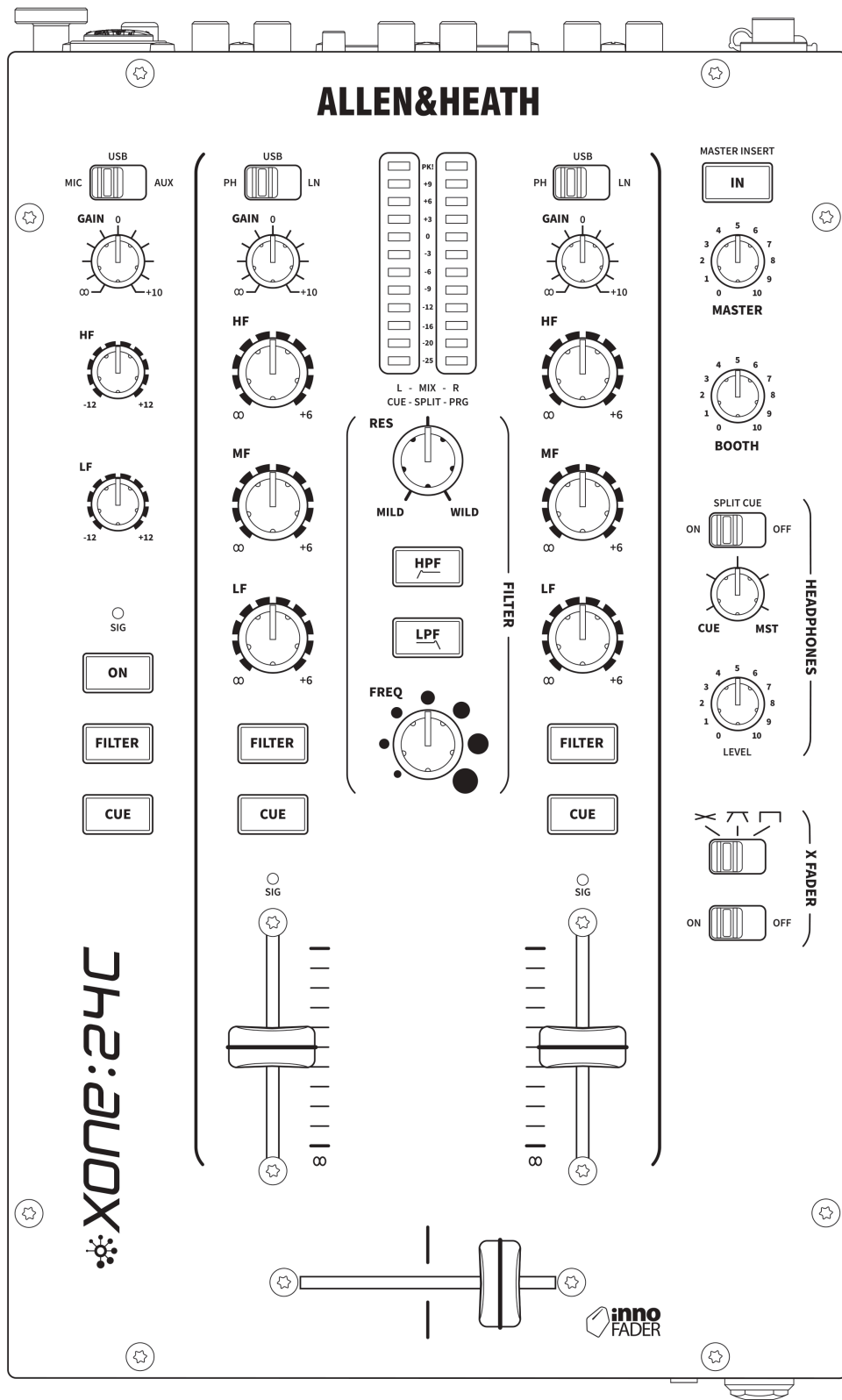

DC Power Supply and IEC cable

QR Card

Follow the QR link access the latest resources for the unit.



Safety and Regulatory Information Booklet

Contains important safety information and should be read before use.



REAR CONNECTORS

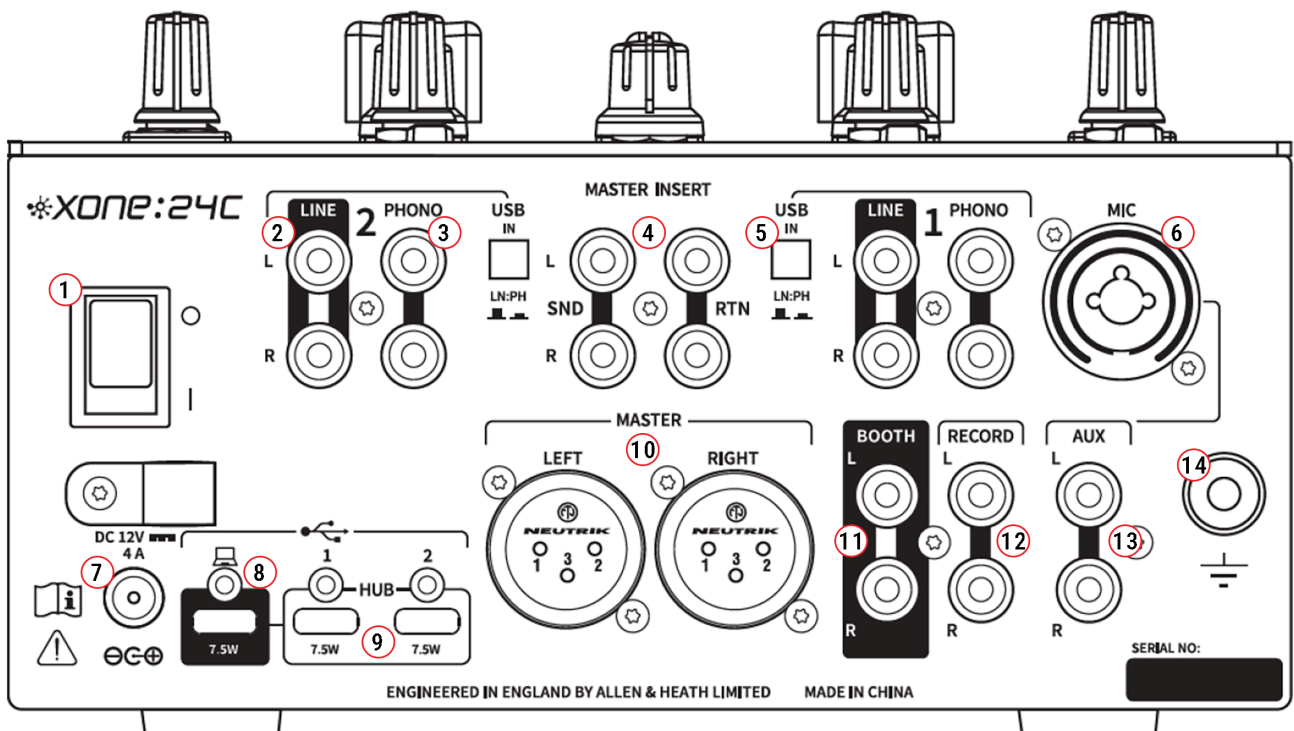

1. Mains Power switch

Turns the mains DC power supply to the mixer ON (I) and OFF (O)

Ensure the DC connector plug is pressed fully into the rear panel socket **before** switching ON.

ⓘ It is standard practice to turn connected power amplifiers, or active speakers, *down* or OFF *before* switching mains power to the mixer ON or OFF to prevent any potential damage to speaker systems due to switch-on transients.

2. LINE Inputs, CH 1 & 2

Unbalanced (RCA). Connect stereo LINE level media players or other audio sources in to the LINE input.

You can also connect other unbalanced LINE level sources using RCA adapters.

ⓘ **Do not** connect turntables requiring RIAA equalisation. And avoid using low grade cables such as those often supplied with domestic equipment as these can impact on the signal path quality and quickly prove unreliable in use.

3. PHONO Inputs, CH 1 & 2

Unbalanced (RCA). Plug in turntables with magnetic cartridges requiring RIAA equalisation. Plug non-RIAA turntables into LINE inputs.

NOTE: **Do not** plug in LINE level sources to the PHONO Inputs as these will overload the preamp and cause severe, high level, signal distortion.

4. MASTER INSERT

Unbalanced (RCA). Connect the **inputs** of your external effects hardware to MASTER INSERT **SND** and its **outputs** to MASTER INSERT **RTN**.

Use the MASTER INSERT **IN** button on the top panel to send audio to your external effects or dynamics processing device.

Alternatively, you can also use the MASTER INSERT to connect dynamics hardware, such as signal limiters or graphics equalizers etc, for inline signal processing before the main mix output stage.

ⓘ **MASTER INSERT** jumpers, connected between **MASTER INSERT SND L / RTN L** and **MASTER INSERT SND R / RTN R**, maintain the continuity of the master signal path when the **MASTER INSERT IN** switch is enabled but no external hardware is connected. This prevents unintended audio interruption in the main output.

5. USB IN LN/PH Source Select Switches, CH 1 & 2

Set Channel 1 & 2 USB IN ('upstream' - mixer to USB host) to LN (for Line level) or PH (for RIAA level) signal input to the USB host. For DVS (CD / Vinyl timecode) control in STREAM and DVS modes*, or to record Channel 1 & 2 hardware inputs via USB.

ⓘ *Refer to the **USB MODE & Soundcard Routing** section below for details.

6. MIC Input, Auxiliary channel

Balanced Combi (XLR or 1/4" TRS Jack). Use a good quality low impedance dynamic microphone.

The XLR connection is wired; Pin1=*Ground*, Pin2=*Hot(+)*, Pin3=*Cold(-)*

TRS Jack connection is wired; Tip=*Hot(+)*, Ring=*Cold(-)*, Sleeve=*Ground*

i **Do not** use high impedance, or condenser microphones that require phantom power. And avoid unbalanced mics wherever possible.

7. DC Mains Input

Connect the (supplied) DC power supply unit to power the mixer.

Check the correct IEC cable with moulded plug compatible to local AC mains supply has been provided with your mixer.

The external power supply unit accepts mains voltages within the range 100-240V without changing any fuses or settings.

8. USB HOST-Port

USB-C. 12 Channel (3 Stereo IN/3 Stereo OUT), 24Bit/96kHz, internal Hi-Speed USB soundcard. macOS / iOS class compliant. ASIO* compatible. Direct, full-duplex MIDI connection.

i Refer to the **USB MODE & Soundcard Routing** section below for full details.

9. Dual USB HUB-Ports

USB-C. Xone:24C's features dual USB-C HUB-Ports that replace X:Link, enabling expanded MIDI control and audio aggregation for DJ or DAW software via a connected computer.

These ports support both the new Xone:K3 and legacy K Series controllers, as well as third-party class-compliant USB-C devices, supporting star topology to allow the host system to recognize each connected device individually.

i Each USB-C port (HOST and HUB) on the Xone:24C provides up to 7.5W of bus power. The HOST-Port is able to provide reverse power to charge class-compliant USB host devices such as tablets and smartphones while connected and in use.

Each HUB-Port allows direct connection and powering of the new Xone:K3 and legacy K Series controllers (Xone:K1 or Xone:K2), as well as third-party devices. Or can be used for charging class-compliant USB bus-powered devices.

10. MASTER Outputs

Balanced (XLR). The main stereo LR MIX outputs that feeds the club PA system, or balanced active speakers. Wired; Pin1=*Ground*, Pin2=*Hot(+)*, Pin3=*Cold(-)*.

11. BOOTH Outputs

Unbalanced (RCA). LINE level stereo output feed with a dedicated level control to the DJ's local monitor.

12. RECORD Outputs

Unbalanced (RCA).

Pre-MASTER level, LR MIX output for connection to external hardware recording devices.

13. LINE Inputs, Auxiliary channel

Unbalanced (RCA). Connect auxiliary stereo LINE level audio sources to the AUX input.

14. Chassis Earth Terminal

A robust ground screw terminal is provided for connecting the earth straps from turntables to prevent ground hum.

 Avoid 'self-grounded' turntables without a dedicated earth strap.

TOP PANEL

ALLEN&HEATH

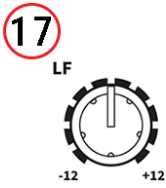
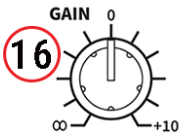
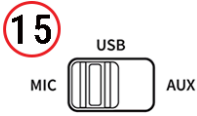

XONE:24C

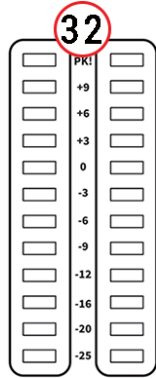
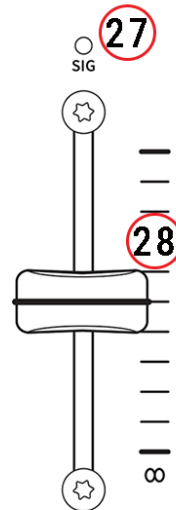
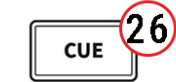
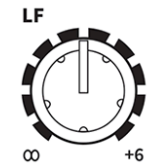
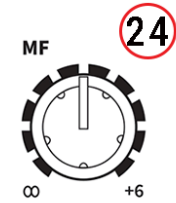
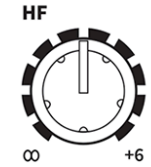
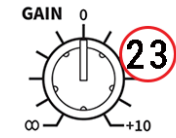
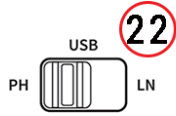

L - MIX - R
CUE - SPLIT - PRG

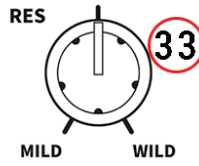

FILTER

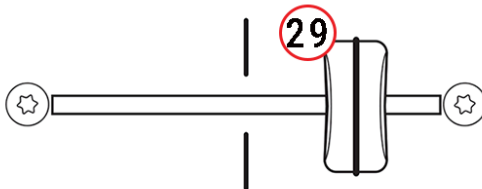
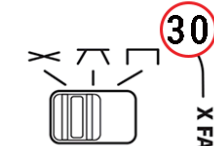
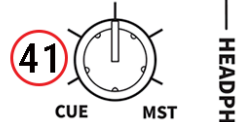
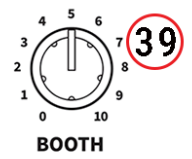
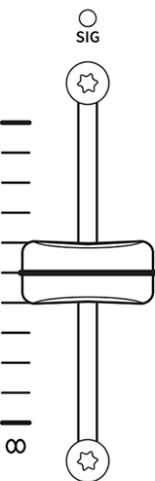
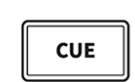
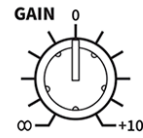
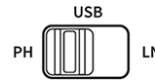

inno FADER



MIC / USB / AUX Inputs. Channel A

15. MIC / USB / AUX Input Select Switch

Switches the auxiliary channel input between MIC, USB, or AUX RCA Line level audio sources.

16. Channel GAIN Control

Adjusts the Channel input sensitivity to compensate for different audio signal source levels. $-\infty/+10$ dB.

17. Channel Equalizer

MIC/ USB/ AUX Channel A, is equipped with a 2 band shelving EQ, providing 12dB of cut or boost to the signal level on each band. Frequencies are set at:

HF Shelving: 4.4kHz - 3dB point (High Frequency, *treble*)

LF: 160Hz - 3dB point (Low Frequency, *bass*)

18. Input Signal Level LED

A tri-colour LED displays the source input level. Green indicates signal is present. Blue indicates signal level between unity (0dB) and +9. If the LED is illuminated RED continuously, turn the Channel GAIN level *down*.

19. Channel ON/OFF Switch

Turns the Channel's audio routed to the master LR MIX and REC outputs ON or OFF. Useful if an un-switched microphone is used to easily bring vocals in and out of a mix.

 This does not affect CH A signal output to CUE.

20. Channel FILTER Assign Switch

Press to route post-GAIN / post-EQ / post-FADER level Channel audio to the FILTER stage. The switch illuminates BLUE when active.

 The FILTER assign switches are also used to configure USB MODE options. Refer to the POWER UP SETUP and USB MODES sections below for details.

21. Channel CUE Switch

Press to listen to the Channel's pre-LR MIX audio in the HEADPHONES monitor outputs and to view its level on the main (MIX) Meters. The switch illuminates RED when active. The

default CUE setting is Non-Latching, where switches remain on until the button is pressed again or another CUE is selected.

ⓘ The CUE assign switches are also used to configure Latching and Non-Latching CUE MODE options.

Refer to the POWER-UP SETUP, POWERED-ON SETUP, and CUE MODES sections below for details.

ⓘ The CUE buttons also output MIDI NOTE commands to the USB HOST-Port.

Refer to the MIDI CONTROL section below for details.

PH / USB / LN INPUTS. Channels 1 and 2

22. PH / USB / LN Input Select Switch

Switches Channel 1 & 2 inputs between RCA PHONO, USB, or RCA LINE level audio sources.

23. Channel GAIN Control

Adjusts the Channel input sensitivity to compensate for different audio signal source levels. $-\infty/+10\text{dB}$.

24. Channel Equalizer

Each Channel is equipped with a powerful 3 band isolator EQ, providing a controlled +6dB boost when fully clockwise and 'Total Kill' full attenuation on each band when fully anticlockwise. Centre/cut-off frequencies are set at:

HF 3.5kHz (High Frequency, *treble*)

MF 1.1kHz (Mid Frequency)

LF 500Hz (Low Frequency, *bass*)

25. Channel FILTER Assign Switch

Press to route post-GAIN / post-EQ / post-FADER level Channel audio to the FILTER stage. The switch illuminates BLUE when active.

ⓘ The FILTER assign switches are also used to configure USB MODE options.

Refer to the POWER-UP SETUP and USB MODES sections below for details.

26. Channel CUE Switch

Press to listen to the Channel's pre-LR MIX audio in the HEADPHONES monitor outputs and to view its level on the main (MIX) Meters. The switch illuminates RED when active. The

default CUE setting is Non-Latching, where switches remain on until the button is pressed again or another CUE is selected.

ⓘ The CUE assign switches are also used to configure Latching and Non-Latching CUE MODE options.

Refer to the POWER-UP SETUP, POWERED-ON SETUP, and CUE MODES sections below for details.

ⓘ The CUE buttons also output MIDI NOTE commands to the USB HOST-Port.

Refer to the MIDI CONTROL section below for details.

27. Channel SIG LED

A tri-colour LED indicates the Channel signal level.

Channel audio is metered post-GAIN / post-EQ and pre-FADER, to display the affect of adjusting EQ on input levels before routing audio to the LR MIX.

Channel GAIN controls should be set so the LED displays green, averaging about **0** on meters when cued, with peaks around **+6** to **+9**, displayed as **blue** on the LED. If the LED continuously displays red, turn the GAIN control *down*.

28. Channel Fader

A high quality, smooth travel, 45mm, dual-rail VCA fader adjusts the Channel signal level routing to the main MIX from fully off to fully on (unity).

ⓘ The channel faders also send MIDI CC to the USB HOST-Port.

Refer to the MIDI CONTROL section below for details.

CROSSFADER

29. X FADER

The crossfader is a mini innoFADER® VCA (voltage controlled amplifier) control that also affects the level of signals routed via the Xone:VCF.

Fade between audio from Channel 1 assigned to the Left, & Channel 2 assigned to the Right side of the crossfader, typically to fade smoothly into a new music track, to creatively layer sounds, or for scratch and cut mixing.

ⓘ Channel 1 fader assignment is fixed to the left (**X**) side of the crossfader. Channel 2 fader assignment is fixed to the right (**Y**) side of the crossfader.

ⓘ The crossfader also sends MIDI CC to the USB HOST-Port.

Refer to the MIDI CONTROL section below for details.

30. X FADER Curve Switch

This switch selects the crossfader response curve between Constant power, Transition, or Fast-cut to suit scratch or cut mixing styles.

31. X FADER ON/OFF Switch

Turns the crossfader ON or OFF.

When OFF, both Channel 1 and Channel 2 bypass the crossfader.

MAIN METERS and FILTER

32. MIX / Monitor Meters

The main meters follow the selected monitor source. By default the meters display the main MIX level, which is overridden by input channel levels when any channel CUE switch is active.

If SPLIT cue mode is enabled, the left (L) MIX meter displays the CUE signal level and the right (R) MIX meter displays mix bus levels. Cued MIX audio level is pre-MASTER, to prevent mismatch due to position of the MASTER level control.

i The mixer should be operated with meters averaging around **0** and loudest peaks between **+6** and **+9**.

If the **PK!** indicator illuminates continuously, ensure GAIN or EQ settings are not clipping the channel SIG indicator and, if necessary, turn Channel GAIN, EQ, or FADERS *down* to prevent LR MIX meters clipping.

Refer to the **OPERATING LEVELS** section for more information.

33. RES Control

The resonance control produces the classic Xone:VCF filter sound by feeding some of the filter output back to its input. The control ranges from MILD, producing a very subtle effect, to WILD, producing a dramatic phase effect with feedback just short of oscillation.

34. HPF Switch

Turns on the High Pass Filter (bass cut) slope.

Refer to the **Filter Reference** section for more information.

35. LPF Switch

Turns on the Low Pass Filter (treble cut) slope.

Refer to the **Filter Reference** section for more information.

36. FREQ Control

The frequency sweep control sets the -3dB cut-off frequency of the Voltage Controlled Filter. It ranges from very low frequency (<20Hz) to very high frequency (>20kHz).

Refer to the **FILTER REFERENCE** section below for more information.

i The HPF and LPF buttons and FREQ control also send MIDI commands to the USB-C HOST-Port.

Refer to the MIDI CONTROL section below for more information.

MASTER and HEADPHONES SECTION

37. MASTER INSERT Switch

Switches external FX or other hardware, such as a limiter, compressor, or graphic equaliser, connected to the rear panel MASTER INSERT sockets IN or OUT of the MASTER mix output.

i By default, MASTER INSERT jumpers are connected between INSERT SND and RTN sockets. If no FX or processing hardware is connected, these must be left in place in order to prevent the main mix audio from cutting out if the MASTER INSERT switch is activated inadvertently.

38. MASTER Level Control

A rotary MASTER control adjusts the level of the main, MASTER 1 and MASTER 2, rear panel outputs feeding the house sound system.

This does not affect BOOTH output level or the meters.

39. BOOTH Level Control

Adjusts the level of the signal to the stereo BOOTH RCA output. This does not affect the headphones level.

The BOOTH output can be used for a DJ Booth monitor, or as an additional zone feed or recording output.

40. SPLIT CUE

Selects the way the CUE bus operates.

Normally, pressing a Channel CUE switch overrides both left and right monitor program signals with the active CUE signal. With SPLIT set ON, the CUE bus overrides just the left channel, leaving the program in the right channel.

L MIX meter displays CUE signal level and R MIX meter displays PRG (LR MIX level) signal.

This is very useful when beat mixing using headphones.

41. CUE / MST Control

Allows the MASTER mix output (MST) to be blended with the CUE signal. Turned fully anticlockwise, only active CUE Channels are heard through the headphones outputs. Gradually turning clockwise introduces the MASTER mix output to the headphones, together with the active CUE.

ⓘ Switching SPLIT CUE, ON automatically overrides the control.

42. HEADPHONES Level Control

Adjusts the level of the audio in the stereo headphones.

ⓘ This does not affect the level of the local booth monitor.

43. Headphone Outputs

Stereo 1/4" TRS jack and 3.5mm mini-jack sockets are located on the front of the mixer. Plug in good quality stereo headphones designed for DJ monitoring.

Use closed-ear headphones to provide maximum acoustic isolation when cueing your sources.

Refer to the **Operating Levels** section for more information.

DRIVER INSTALLATION (PC only)

ⓘ Apple® Operating Systems

The Xone:24C features an Apple CoreAudio and CoreMIDI class compliant interface that will work on macOS® iPadOS™ and iOS platforms without any requirement to install hardware device drivers.

Microsoft Windows® PC

In order for a PC to access all USB Host soundcard channels on your Xone:24C you will need to install the dedicated, ASIO® compatible, Device Drivers, which can be downloaded from the Allen & Heath website

Please ensure you are logged on to the PC with Administrator access enabled

When the driver package has downloaded, extract the installer to your computer desktop.

Double-click on the **Xone:24C Driver Setup** file to begin.

The installer will also prompt you through the steps necessary to install this software. Follow the on-screen instructions.

Click **Yes** on the User Account Control prompt to confirm and continue installation.

Click **Next** to run the installer application.

Click on the **Install** tab to pre-install the Device Drivers to the default system folder.

A series of messages will be displayed...

This may take some time to complete.

Please wait while Xone:24C v5.72.0 software is installed...

Click **Install** if prompted to install *Allen&Heath Sound, video and game controllers* software.

Click **Install** if prompted to install *Allen&Heath Xone:24C Audio Devices* software.

Connect the Xone:24C mixer to your PC via the USB-Host port and power the unit **ON***.

Click **Next** to continue once the pre-installation process has completed.

Click **Finish** to complete the Device Driver installation.

NOTE: * It is possible to run the Xone:24C Device Driver pre-installation process without connecting the mixer to your computer. In this case you will be prompted to *"...disconnect and reconnect the device to complete driver installation."*

If the mixer cannot be connected, click **Yes** on the prompt to close the application. To complete installation, connect the Xone:24C to your PC via the USB-Host port and power the mixer **ON**. Wait a few moments for the PC to enumerate the mixer before opening your software application.

DEVICE CHECKS (Mac and PC)

When first connecting the Xone:24C to a Mac or PC computer, before opening your Digital DJ or DAW software, check the interface is being recognised correctly by the system as follows:

Apple macOS

1. Connect the Xone:24C to your Mac via the USB-Host port.
2. On the Mac, navigate to: *Finder / Applications / Utilities / Audio MIDI Setup*
3. From the *Windows* menu, select: **Show Audio Devices**

4. In the Input and Output sections, 6 channels should be displayed.

The **Format:** menu displays the currently selected sample rate and bit depth

Sample rate is selectable from 44.1 to 96kHz.

Bit depth is selectable between 16bits and 24bits

Device Settings should be adjusted as required to suit particular applications and the host system's CPU capacity.

5. Next, select **Show MIDI Studio** and check the Xone:24C icon is displayed and highlighted.

Microsoft Windows PC

1. Connect the Xone:24C to your PC via the USB host port.

2. On your PC, open the Xone:24C Control Panel

Status view displays: Xone:24C and Current Sample Rate

Format view Input and Output sections display: 12 channels and the currently selected bit depth.

Sample Rate is selectable from 44.1 to 96kHz.

Bit depth is selectable between 16bits and 24bits

Device Settings can be adjusted as required to suit applications or host system's CPU capacity.

3. Next, navigate to: *START / Settings / Devices / Device Manager*

4. Expand the **Audio inputs and outputs** tree to display;

Line (Xone:24C) and Speakers (Xone:24C)

5. Expand **Sound, Video and Game Controllers** and **Xone:24C Audio Devices** trees to display;

Xone:24C

USB and CUE MODES

USB MODES

The Xone:24C supports three full-duplex USB audio routing modes, accessible via the USB-C HOST-Port.

All USB modes provide three stereo input sources - Channel 1, Channel 2, and auxiliary Channel A - allowing DJs to mix digital audio from DJ software directly into the mixer by selecting USB inputs on each mixer channel.

Mode 1: STREAM Mode

Designed for simple use with basic DJ or recording software that lacks multi-channel audio support. It allows DJs to stream or record the master mix on the host computer.

i USB MODE 1 is the mixer's default soundcard configuration.

Modes 1 & 2: STREAM / DVS PRO

Both modes support DVS (Digital Vinyl System) using RCA-connected turntables or LINE level media players on Channels 1 and 2. This enables timecode control for compatible DJ software running on a device connected via the HOST-Port.

Mode 3: DAW Mode

DAW Mode introduces a per-channel recording workflow, ideal for capturing real-time analogue stem mixes. It enables DJs to export individual channels into a DAW environment for post-performance editing - ideal for re-editing, re-sampling, re-mixing, and sharing high-quality mixes.

i Refer to the **USB MODE & Soundcard Routing** section below for full details.

i USB MODE routing configurations options can *only* be set while turning the mixer on, by using the POWER-UP Setup process described below.

CUE MODES

Two options are also available to configure how the CUE buttons can function:

- CUE MODE 1: Non-latching - Is the mixer's default setting, one CUE remains on until the button is pressed again or another channel CUE is selected.
- CUE MODE 2: Latching - Enables CUE switches to remain active when selecting another channel CUE. Any active CUE is deactivated by pressing the button again.

i CUE MODE options are configured using the red Channel 1 and Channel 2 CUE buttons during the POWER-UP Setup process described below and 'on-the-fly' while the mixer is

on, following the POWERED-ON Setup method below.

POWER-UP Setup

ⓘ The mixer must be OFF before beginning the POWER-UP Setup process required to change the USB MODE routing configuration.

To enter POWER-UP Setup:

1. Press and hold down both Channel 1 and Channel 2 CUE buttons on the top panel.
2. Power the mixer ON using the rear panel standby switch. Keeping Channel 1 and Channel 2 CUE buttons pressed down for @3 seconds after the mixer is switched on.
3. Release both CUE buttons
The AUX channel CUE button blinks red rapidly to show the mixer is in its setup state.

USB MODE Setup

The flashing blue FILTER button shows the current USB MODE, described above

5. Press the FILTER button for the required USB MODE to change between the sound card USB IN routing configurations:
 - AUX FILTER = STREAM MODE
 - CH 1 FILTER = DVS PRO MODE
 - CH 2 FILTER = DAW MODE

ⓘ Refer to the **USB MODES and Soundcard Routing** section below for full details.

CUE MODE Setup

The flashing red Channel 1 or Channel 2 CUE button shows the current CUE MODE, described above

6. Press the CUE button for the required CUE MODE to change the CUE button function:
 - CH 1 CUE = Non-latching Cues
 - CH 2 CUE = Latching Cues
7. Press the AUX Channel CUE button to store the changes and exit the POWER-UP Setup process.

POWERED-ON Setup

1. Press and hold down both Channel 1 and Channel 2 CUE buttons for 5s

2. The AUX channel's CUE button blinks red rapidly to show that the mixer is in its setup state.

[image 23: top panel CUE switches]

3. Press the CUE button for the required CUE MODE to change the CUE button function. The flashing red Channel 1 or Channel 2 CUE button shows the current CUE MODE, described above:

CH 1 CUE = Non-latching CUEs

CH 2 CUE = Latching CUEs

4. Press the AUX Channel CUE button to store the changes and exit the POWER-UP Setup process.

- ⓘ When POWERED-ON Setup is active, the headphones output is muted. And restored on exiting the POWERED-ON Setup process.
- ⓘ If a CUE button is active when you enter the POWERED-ON Setup process, the same state is retained on exiting POWERED-ON Setup, and the changed CUE MODE is available following the next CUE button press.
- ⓘ The last selected USB and CUE modes remain stored in the mixer when powered off, and are recalled when the mixer is next switched on, until subsequent changes are made.

USB MODES and Soundcard Routing

SOUNDCARD OUTPUTS

All USB Modes provide three stereo audio outputs from a device connected via the mixer's USB-C HOST-Port

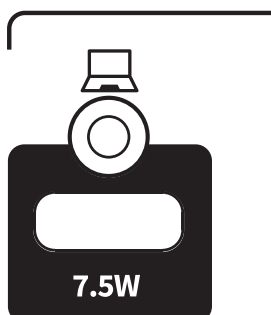

These soundcard outputs are routed to the mixer's Channel 1, Channel 2, and auxiliary Channel A inputs by setting each channel's input select switch to USB.

- **CH1 USB L** and **CH1 USB R** → Routed to **Channel 1**
- **CH2 USB L** and **CH2 USB R** → Routed to **Channel 2**
- **AUX USB L** and **AUX USB R** → Routed to auxiliary **Channel A**

This fixed soundcard output routing configuration applies across all USB Modes, enabling easy assignment of Channels 1 and 2 to the first two virtual decks in most DJ software that supports external mixing. This mapping typically aligns with default software settings.

The third stereo output (AUX USB L/R) remains available for the auxiliary Channel A, commonly used for:

- A sampler deck or sequencer
- A third virtual deck
- A VST software FX return
- Audio from a separate application
- Aggregated device outputs from the USB host device

SOUNDCARD INPUTS

Each USB Mode reconfigures the signal routing to the soundcard's input channels and updates their naming, making it easier to identify sources within the host system's audio device settings, including those in DJ software or DAWs.

USB Mode 1 (**STREAM**) and USB Mode 2 (**DVS PRO**) route the mixer's Channel 1 and Channel 2 RCA inputs to the soundcard inputs. This allows control signals from turntables, CDJs, or PHASE controllers etc. to be sent to the host device connected via the USB-C HOST-Port, enabling DVS timecode control within compatible software.

USB MODES

Xone:24C supports three USB modes, each offering unique signal routing configurations for audio streaming, DVS control, and DAW integration. All modes utilize the USB-C HOST-Port and are designed to integrate with various DJ software and DAWs.

USB Mode 1: STREAM

STREAM Mode is the default soundcard configuration. This mode routes the mixer's master output (post-CLEAN FEED) to the first stereo USB IN pair, labeled in most software as:

MIX OUT L and **MIX OUT R**

Ideal for streaming or recording in applications that don't support multi-channel audio.

STREAM Mode also provides simultaneous DVS input for Digital DJs:

Channel 1 RCA inputs (pre-GAIN/EQ) → second stereo USB IN pair:

CH1 DVS PH/LN L and **CH1 DVS PH/LN R**

CH2 RCA inputs (pre-GAIN/EQ) → third stereo input pair:

CH2 DVS PH/LN L and **CH2 DVS PH/LN R**

USB Mode 2: DVS PRO

DVS PRO Mode optimizes routing for full DVS integration with DJ software that supports multi-channel USB audio.

Channel 1 RCA inputs (pre-GAIN/EQ) → first stereo USB IN pair:

CH1 DVS PH/LN L and **CH1 DVS PH/LN R**

Channel 2 RCA inputs (pre-GAIN/EQ) → second stereo USB IN pair:

CH2 DVS PH/LN L and **CH2 DVS PH/LN R**

These naming conventions align with most DVS software's default input configurations.

Master Output (Post-CLEAN FEED) → third stereo input pair:

MIX OUT L and **MIX OUT R**

Enables high-quality recording in DJ software, or any DAW supporting multi-channel USB audio. And is also compatible with live-streaming apps that support multi-channel audio input.

USB Mode 3: DAW

DAW Mode enables per-channel, post-EQ, pre-fader recording, ideal for stem capture and post-production workflows. Ideal for recording clean stems for re-editing, re-sampling, or remixing in a DAW environment.

Channel 1 (post-EQ, pre-fader) → first stereo USB IN pair:

CH1 Post EQ L and **CH1 Post EQ R**

Channel 2 (post-EQ, pre-fader) → second stereo USB IN pair:

CH2 Post EQ L and **CH2 Post EQ R**

Master out (post-CLEAN FEED) → third stereo USB IN pair:

MIX OUT L and **MIX OUT R**

Enables high-quality recording in DJ software, or any DAW supporting multi-channel USB audio. And is also compatible with **live-streaming apps** that support multi-channel audio input.

Advanced USB Audio Integration

Technically advanced users can also:

Combine analog and digital sources across all three channels.

Use the mixer's HOST-to-HUB / HUB-to-HOST USB architecture to connect external USB-C

MIDI or audio hardware via the HUB-Ports.

Route and aggregate digital signals from external devices directly into the host system.

Return audio aggregated on the host to the mixer by selecting USB input on Channel 1, Channel 2, and auxiliary Channel A.

→ This device aggregation feature is supported in all USB Modes.

XONE:24C USB SOUND CARD ROUTING

MIXER CHANNELS + MIX LR >> TO >> SOFTWARE INPUTS via USB C HOST-Port	
USB MODE 1	STREAM
HOST-Port USB INPUT Channel	MASTER L/R OUT to USB IN 1/2 CH1 RCA (RIAA / LINE) to USB IN 3/4 CH2 RCA (RIAA / LINE) to USB IN 5/6
HOST NAME	MIX OUT L ; MIX OUT R
USB IN 1	MIX L : Master L ; Post Insert / Post CleanFeed / Pre Master Level
USB IN 2	MIX R : Master R ; Post Insert / Post CleanFeed / Pre Master Level
HOST NAME	CH1 DVS PH/LN L ; CH1 DVS PH/LN R
USB IN 3	CH 1 L : PHONO or LINE RCA Input ; Pre Gain Level
USB IN 4	CH 1 R : PHONO or LINE RCA Input ; Pre Gain Level
HOST NAME	CH2 DVS PH/LN L ; CH2 DVS PH/LN R

USB IN 5	CH 2 L : PHONO or LINE RCA Input ; Pre Gain Level
USB IN 6	CH 2 R : PHONO or LINE RCA Input ; Pre Gain Level
USB MODE 2	DVS PRO
HOST-Port USB INPUT Channel	CH1 RCA (RIAA / LINE) to USB IN 1/2 CH2 RCA (RIAA / LINE) to USB IN 3/4 MASTER L/R OUT to USB IN 5/6
HOST NAME	CH1 DVS PH/LN L ; CH1 DVS PH/LN R
USB IN 1	CHANNEL 1 L : PHONO or LINE RCA Input ; Pre Gain Level
USB IN 2	CHANNEL 1 R : PHONO or LINE RCA Input ; Pre Gain Level
HOST NAME	CH2 DVS PH/LN L ; CH2 DVS PH/LN R
USB IN 3	CHANNEL 2 L : PHONO or LINE RCA Input ; Pre Gain Level
USB IN 4	CHANNEL 2 R : PHONO or LINE RCA Input ; Pre Gain Level
HOST NAME	MIX OUT L ; MIX OUT R
USB IN 5	MIX L : Master L ; Post Insert / Post CleanFeed / Pre Master Level
USB IN 6	MIX R : Master R ; Post Insert / Post CleanFeed / Pre Master Level
USB MODE 3	DAW MODE

HOST-Port USB INPUT Channel	CH1 Post-EQ / Pre-FADER to USB IN 1/2 CH2 Post-EQ / Pre-FADER to USB IN 3/4 MASTER L/R OUT to USB IN 5/6
HOST NAME	CH1 Post EQ L CH1 Post EQ R
USB IN 1	CHANNEL 1 L : Post Channel EQ / Pre Channel Fader Level
USB IN 2	CHANNEL 1 R : Post-EQ / Pre-Fader Level
HOST NAME	CH2 Post EQ L CH2 Post EQ R
USB IN 3	CHANNEL 2 L : Post-EQ / Pre-Fader Level
USB IN 4	CHANNEL 2 R : Post-EQ / Pre-Fader Level
HOST NAME	MIX OUT L MIX OUT R
USB IN 5	MIX L : Master L Post Insert / Post CleanFeed / Pre Master Level
USB IN 6	MIX R : Master R Post Insert / Post CleanFeed / Pre Master Level
SOFTWARE OUTPUTS via USB C HOST-Port >> TO >> MIXER CHANNEL USB INPUTS	
USB MODE	ALL MODES
HOST-Port USB OUTPUT Channels	USB OUT 1/2 to CHANNEL 1 USB L/R USB OUT 3/4 to CHANNEL 2 USB L/R USB OUT 5/6 to CHANNEL A USB L/R
HOST NAME	CH 1 USB L CH 1 USB R

USB OUT 1	CHANNEL 1 L : USB INPUT
USB OUT 2	CHANNEL 1 R : USB INPUT
HOST NAME	CH 2 USB L CH 2 USB R
USB OUT 1	CHANNEL 2 L : USB INPUT
USB OUT 2	CHANNEL 2 R : USB INPUT
HOST NAME	AUX USB L AUX USB R
USB OUT 1	CHANNEL A L : USB INPUT
USB OUT 2	CHANNEL A R : USB INPUT

THE DUAL USB HUB

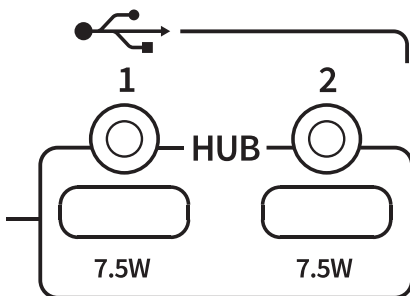

Xone:24C's dual USB-C HUB-Port interface replaces X:Link, enabling expansive MIDI control (HOST-to-HUB and HUB-to-HOST) of DJ applications or DAW software running on computers or other devices connected via the soundcard's HOST-Port. This is achieved by connecting Xone:K3s, legacy K Series controllers (Xone:K1 / Xone::K2), or other compatible devices to the two USB-C HUB-Ports.

Connecting External Hardware

In addition to connecting Xone:K Series devices, the HUB-Ports support third-party USB-C class-compliant controllers for MIDI control of software running on a computer connected

to the HOST-Port. They also support USB-C class-compliant digital audio devices for audio aggregation on the HOST-Port device. The HUB-Ports accommodate a star topology, allowing the host system to recognize connected controllers and audio devices as discrete units.

ⓘ The mixer's HOST-Port and each HUB-Port can supply bus power (up to 7.5W per port) to connected USB-C class-compliant devices. This allows for direct connection of Xone:K3s, legacy K Series controllers, and third-party bus-powered controllers - or for powering and charging compatible devices such as tablets, smartphones, and other USB-C peripherals.

MIDI CONTROL

MIDI stands for **M**usical **I**nstrument **D**igital **I**nterface; a protocol established in the 1980s to enable different keyboards, sequencers, drum machines, etc. to communicate with each other. MIDI remains a common and popular means to enable remote control of functions within DJ performance, or DAW (Digital Audio Workstation) software.

Key mixer functions now support USB MIDI via the USB-C Host-Port interface. The following controls can transmit MIDI data directly to the USB Host device:

- CH1 & CH2 up-faders
- mini innoFADER® crossfader
- Xone:VCF HPF/LPF buttons and FREQ control
- Channel FILTER assign buttons
- CUE assign buttons
- MASTER INSERT IN button

In USB Mode 3, **DAW Mode**, real-time fader movements from Channel 1, Channel 2 and the crossfader can be recorded as MIDI automation, enabling playback, re-editing, or re-mixing of a DJ set in DAW software post-performance.

Additionally, MIDI outputs can be used to control DJ applications, DAWs, post-mix production markers, or other real-time applications - such as video, streaming cues or lighting system controls.

The Xone:24C's Dual USB-Hub ports can be used to connect external MIDI controllers for full-duplex control between HOST and HUB devices. Refer to the DUAL USB HUB section below for details.

Xone:24C also has the ability to send MIDI data directly from controls on the mixer to the USB-Host port, for remote control of MIDI compatible software.

Refer to the color-coded image and table below for MIDI control and command details

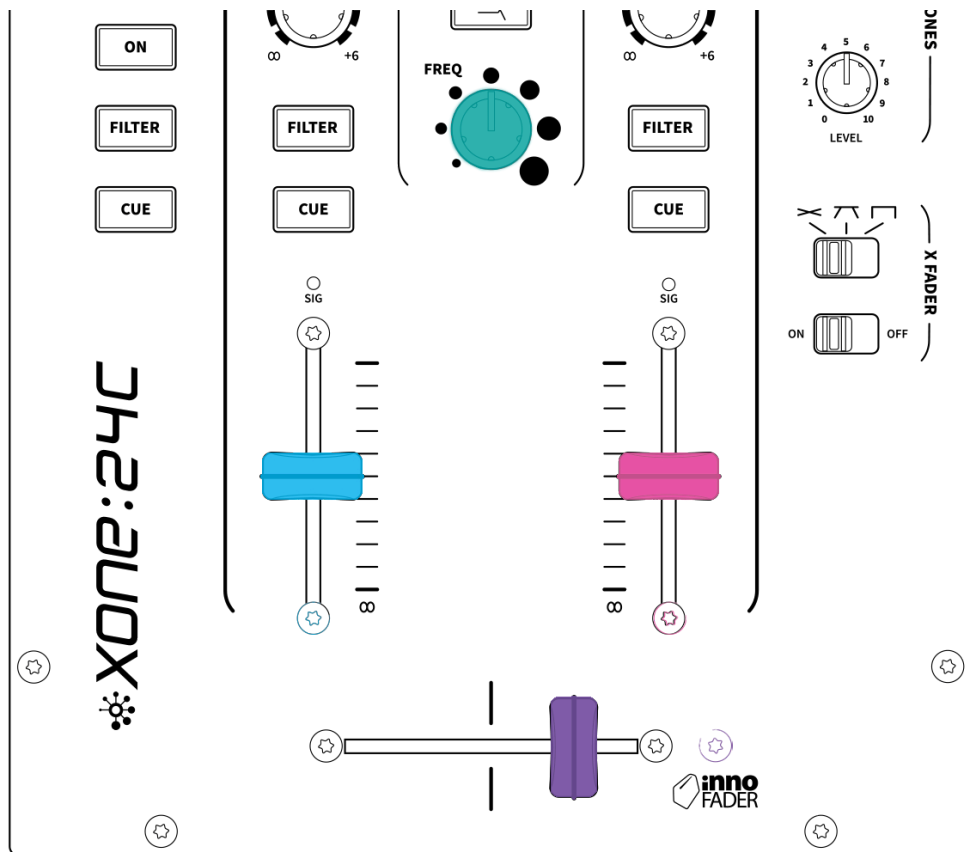

CONTROL	MIDI CH	CC / NOTE	DATA 1	DATA 2	VAL (RANGE)
XFADER	16	CC	04	VAL	0 - 127 (CH1 - CH2)
CH 1 FADER	16	CC	05	VAL	0 - 127 (MIN - MAX)
CH2 FADER	16	CC	06	VAL	0 - 127 (MIN - MAX)
FREQ	16	CC	07	VAL	126 - 0 (MILD - WILD)

ⓘ Xone:24C's MIDI control commands are fixed to output on MIDI Channel 16.

The **MIDI CONVERSION TABLE** details conversions between decimal, hexadecimal, and chromatic scale formats.

BLOCK DIAGRAM

XONE:24C SIGNAL FLOW DIAGRAM

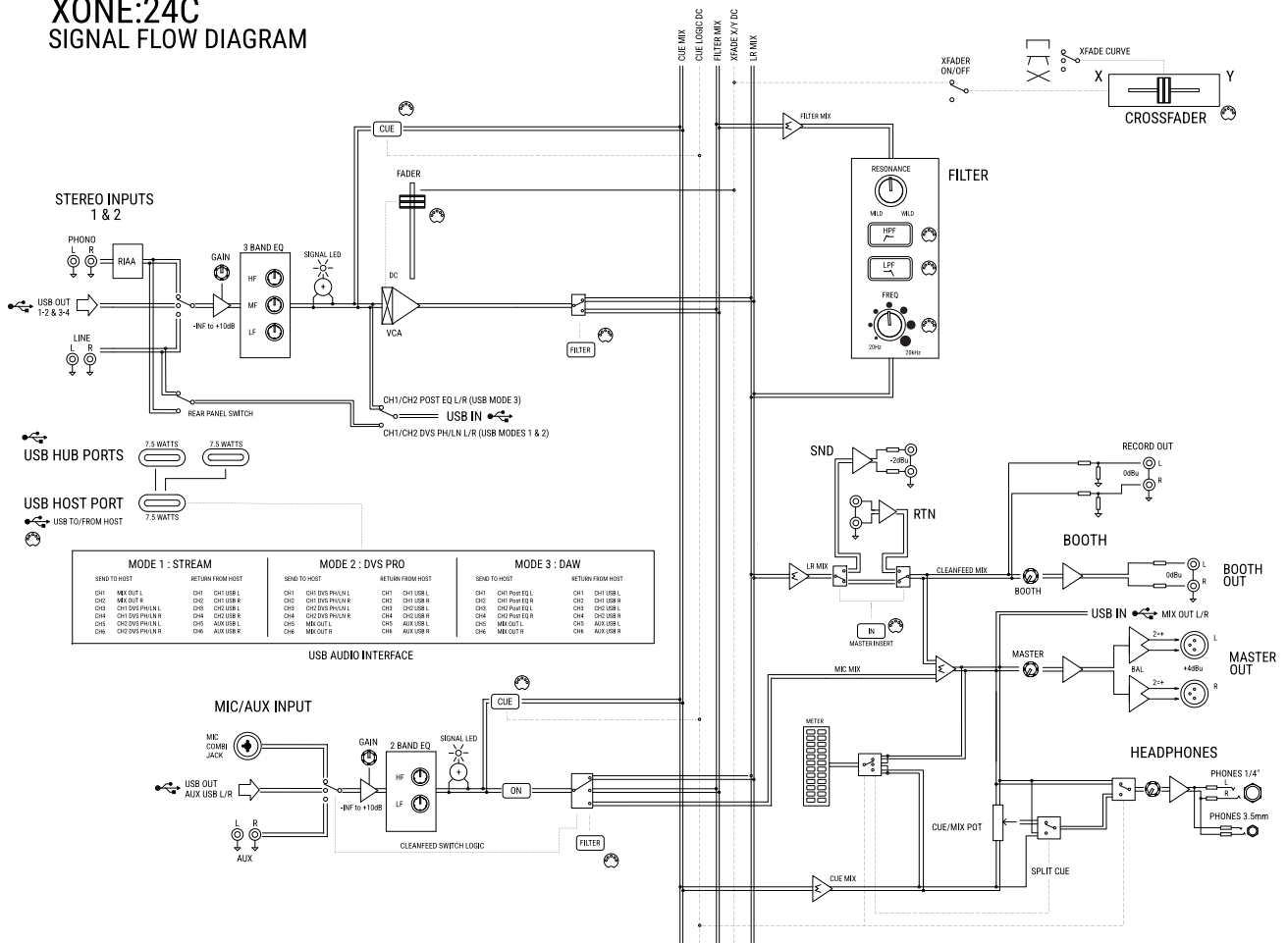

SPECIFICATIONS

Technical Specification

Model	Xone:24
Type	Hybrid: Analogue + Internal USB-C Soundcard and Dual-port USB-C hub
Channels	2 + 1
CH1&CH2	Phono/USB/Line
AUX CH	Mic/USB/Line
Line Inputs	3 x RCA (CH 1 & 2 + Aux CH)
Phono Inputs	2 x RCA (CH 1 & 2)
RIAA Gain	+42dB @ 1kHz, 6mV RMS= 0VU @ 1kHz

Mic Input	1 x Combi (XLR + TRS)
Mic Gain	+40dB, EIN = -115dB @ 40dB gain with 150R source
Master Output	1 x XLR (Balanced)
Level	+4dBu (Nominal), +22dBu (Max)
Residual Noise	-93dBu
Mix Noise	-83dBu
Booth Output	1 x RCA (Un-balanced)
Level	0dBu (Nominal), +18dBu (Max)
Residual Noise	-93dBu
Mix Noise	-83dBu
Record Output	1 x RCA (Un-balanced)
Level	-10dBV (Nominal), +8dBV (Max)
Mix Noise	-83dBu
Stereo Master Insert	2 x RCA MASTER INSERT Send
	2 x RCA MASTER INSERT Return
Level	-2dBu (Nominal), +18dBu (Max)
Headphones	1 × 1/4", 1× 3.5mm
	Split Cue Monitoring
Frequency response	+/-0.5dB from 20Hz to 30kHz (Line In → Master Out)
Internal headroom	+18dB
Distortion	Typically 0.01% @ 1kHz 0dBu
Crosstalk	< -85dB inter-channel @ 1kHz +10dBu
EQ (CH1&CH2)	3-band, +6dBu / Total Kill
HF (Shelving)	> 3.5kHz
MF	1.1kHz
LF (Shelving)	< 500Hz
	Total Kill attenuation: -75dB
EQ (AUX CH)	2-band, +/- 12dB

HF (Shelving)	4.4kHz (3dB point)
LF (Shelving)	160Hz (3dB point)
Analogue Filter	1 x Voltage Controlled Filter
	HPF / LPF
	Adjustable Frequency & Resonance
	Assignable CH 1 & 2 + Aux CH
Channel Faders	45mm Voltage Controlled Amplifier
Channel Fader Cut Off	< -90dB @ 1kHz +10dBu
X-Fader	45mm VCA mini innoFADER®
X-Fader Curve Settings	3 Types (Constant power, Transition, Fast-cut)
X-Fader Cut Off	< -90dB @ 1kHz +10dBu
Earth Ground Terminals	x 1
Headroom	+18dB
Mix Meters	12 LED (-25dBu to +12dBu)
Chanel Meters	Single tri-colour LED
GREEN	-25dBu to 0dBu
BLUE	> 0dBu to +12dBu
RED	> 12dBu
Internal Soundcard	
Digital Architecture [USB] Specification	6 Channel* 24-bit/96kHz capable** USB 2.0
	*12 Channel: 3 x Stereo In / 3 x Stereo Out
3 Mode USB IN Operation	STREAM MODE / DVS PRO MODE / DAW MODE
USB Audio & USB MIDI I/O	
1 x HOST-Port	USB Type C
	Full-duplex Audio: Mixer to HOST-Port
	MIDI Out: Mixer to HOST-Port
2 x HUB-Ports	USB Type C

	Full-duplex Audio and MIDI: HOST-Port to HUB-Ports
Analogue/Digital Line-up	0dBu = -15dBFS
Supported Variable Buffer Sizes	32 / 64 / 128 / 256 / 512 / 1024 / 2048 / 4096 / 8192 samples
Supported Sample Rates	**44.1 kHz / 48kHz / 88.2kHz / 96kHz
Supported Bit depth	**16 bit / 24 bit
MIDI Controls	Yes
MIDI CC	CH1 & CH2 Faders, Crossfader, VCF FREQ
MIDI Out	1x USB HOST-Port (Type C)
	2x USB HUB-Ports: HOST-to-HUB / HUB-to-HOST only (Type C)
DC Mains	100 to 240V
	AC 50/60Hz
	Consumption 35W max
USB Power delivery	USB HOST-Port (Type C): 1 × 7.5W
	USB HUB-Ports (Type C): 2 × 7.5W
Mains Adaptor	2 pin DC socket with cable clamp

WEIGHTS & DIMENSIONS

XONE:24	UN-PACKED		PACKED	
Height	108mm	4.25"	210mm	8.25"
Width	190mm	7.48"	310mm	12.25"
Depth	314mm	12.36"	400mm	15.75"
Weight	2.8kg	6.17lbs	4kg	9 lbs

PANEL DRAWINGS

Top panel

190mm

314mm
300mm

ALLEN&HEATH

USB
MIC AUX

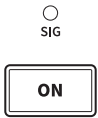
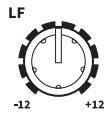
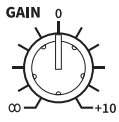

742:2UOX

USB
PH LN

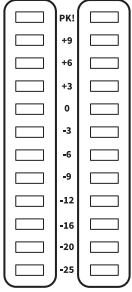
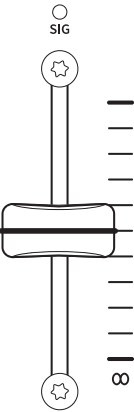
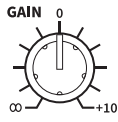

L - MIX - R
CUE - SPLIT - PRG

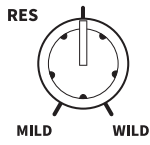

FILTER

USB
PH LN

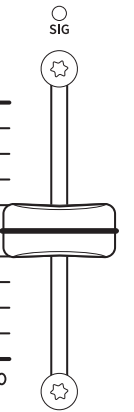
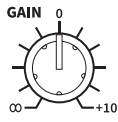

MASTER INSERT

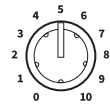

MASTER

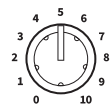

BOOTH

SPLIT CUE
ON OFF

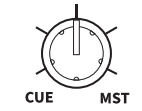

CUE MST



LEVEL

HEADPHONES

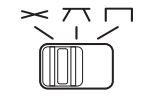

X FADER

inno
FADER

Rear panel

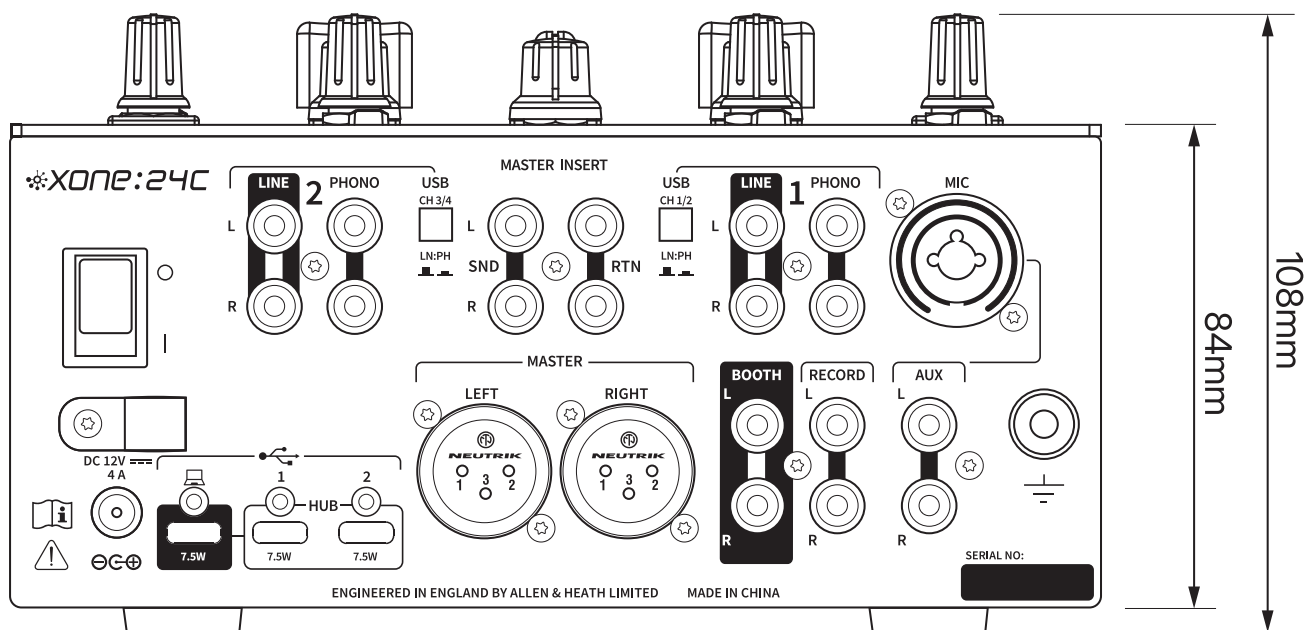

Front panel

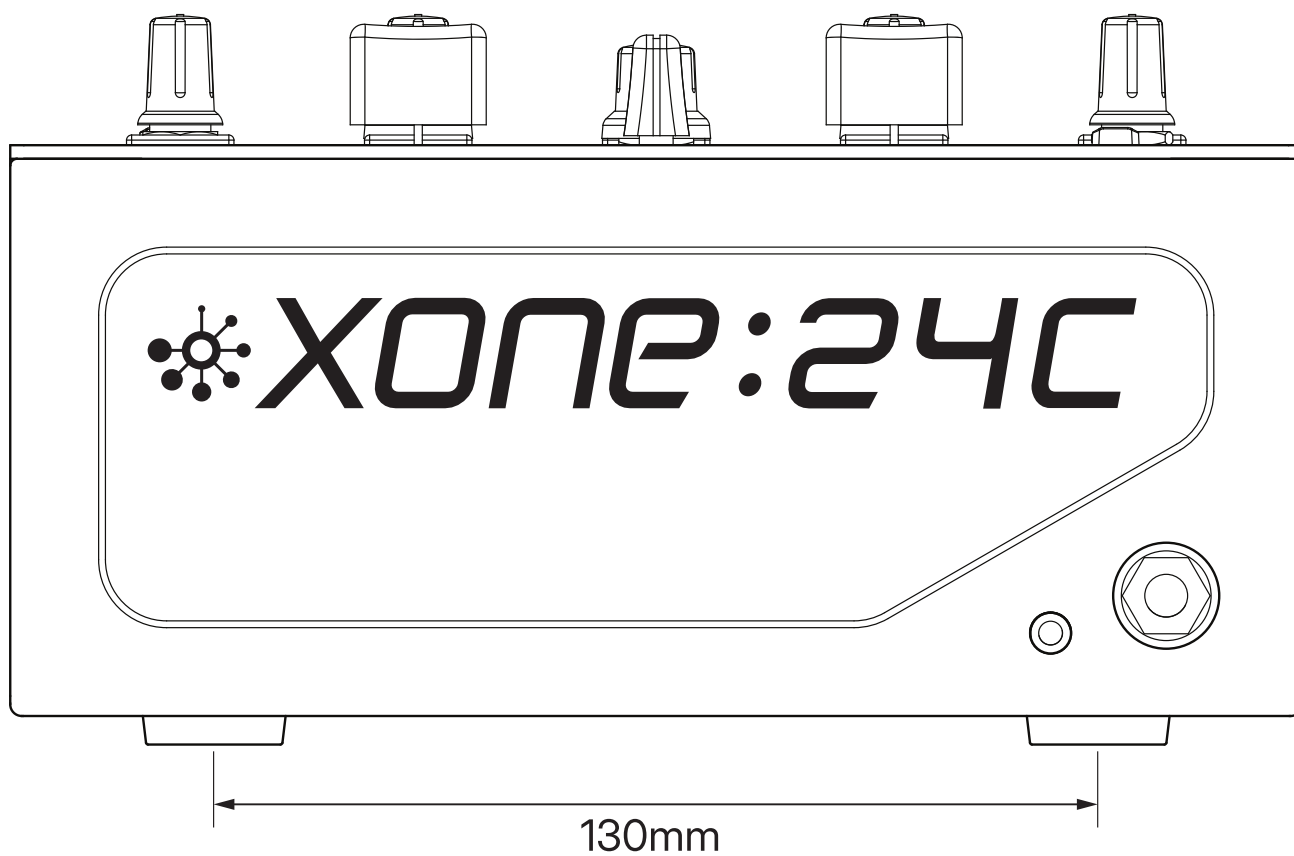

Side panel [left]

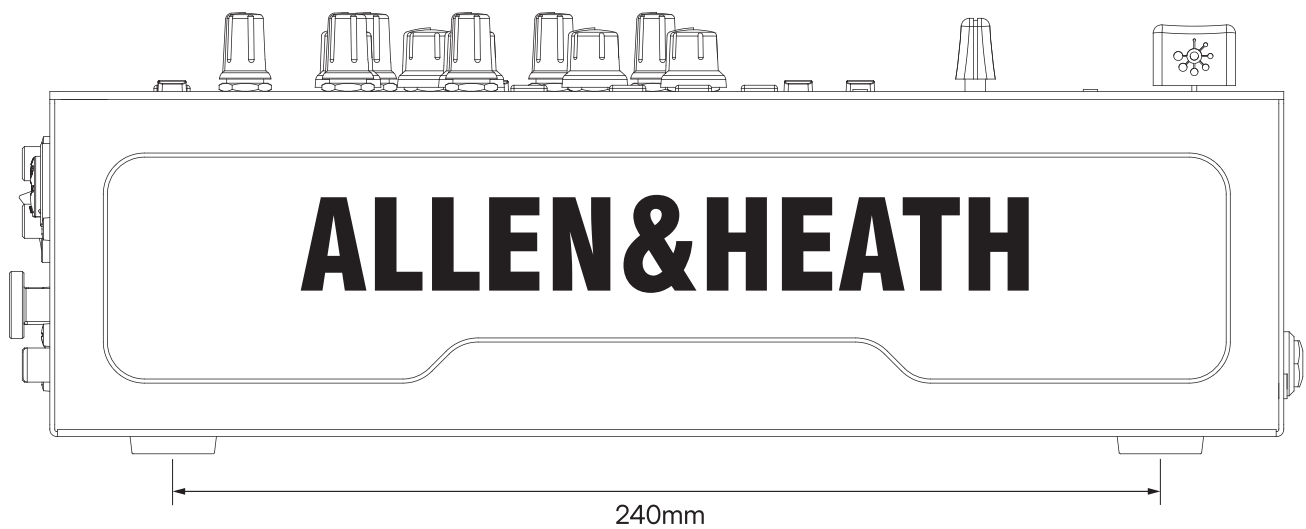

FILTER REFERENCE

The Xone:VCF Voltage Controlled Filter

A Voltage Controlled Filter is an audio filter where the cut-off frequency is altered by a DC control voltage rather than a variable resistor. This produces a much wider operating range and more control over the filter response to create unlimited combinations of dynamic tonal effects

Filter Type Select

The filter is 'state variable' providing two responses: high-pass (HPF) and low-pass (LPF). Two large, illuminated switches select which type is active. Pressing one switch automatically deselects the other.

The switches implement analogue soft-switching, ensuring the MIX output is unaffected by audible electronic artefacts when selecting different Filter Types and assigning channels to the FILTER.

i The filter response defaults to HPF output and channel FILTER assignments are set OFF when mains power to the mixer is turned OFF.

The graphs below show typical effects on audio frequency response for the two filter types.

The range of sweep from low to high frequency is shown together with the effect of adjusting together with the effect of adjusting the filter resonance to MILD, WILD and centred positions: one frequency with RES and FREQ set to minimum, 12 o'clock, and max.

The vertical scale shows the amount of cut or boost around the normal 0dB operating level. The horizontal scale shows the change in frequency from low (bass) to high (treble).

HPF response

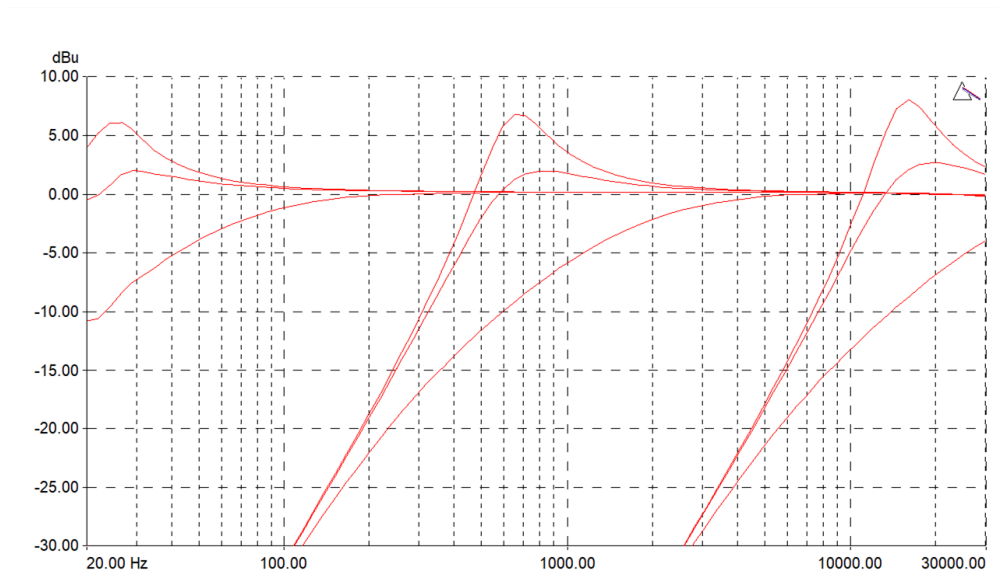

LPF Response

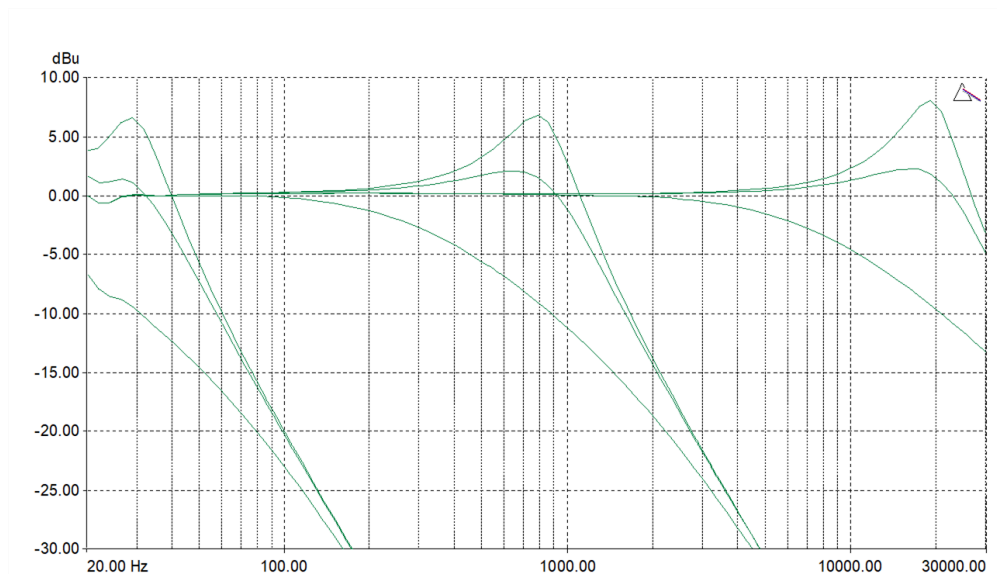

Operating Levels

It is most important that the system level settings are correctly set. It is well known that many DJs push the level to maximum with meters peaking hard in the belief that they are getting the best from the system.

THIS IS NOT THE CASE

The best can only be achieved if the system levels are set within the normal operating range and not allowed to peak. Peaking simply results in signal distortion, not more volume.

It is the specification of the amplifier / speaker system that sets the maximum volume that can be achieved, not the console. The human ear too can fool the operator into believing that more volume is needed. Be careful as this is in fact a warning that hearing damage will result if high listening levels are maintained.

Remember that it is the **QUALITY** of the sound that pleases the ear, not the **VOLUME**.

The diagram below illustrates the **NORMAL OPERATING RANGE** of the audio signal.

For normal music the signal should range between -6 and $+6$ on the meters with average around 0 dB.

This allows enough **HEADROOM** for unexpected peaks before the signal hits its maximum **CLIPPING** voltage and distorts. It also achieves the best **SIGNAL-TO-NOISE-RATIO** by keeping the signal well above the residual **NOISE FLOOR** (system hiss).

The **DYNAMIC RANGE** is the maximum signal swing available between the residual noise floor and clipping.

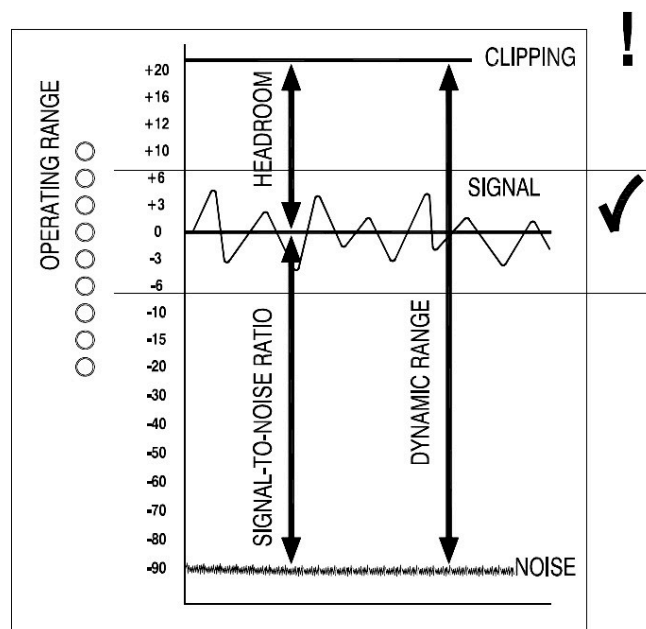

An important note ... The human ear is a remarkable organ with the ability to compress or 'shut down' when sound levels become too high.

Do not interpret this natural response as a reason to turn the system volume up further ! As the session wears on ear fatigue may set in, and the speaker cones may become hot so reducing the effectiveness of the system and listeners to gain any benefit from increased volume.

BE SENSIBLE. BE SAFE WITH SOUND LEVELS.

Earthing

The connection to earth (ground) in an audio system is important for two reasons:

SAFETY - To protect the operator from high voltage electric shock, and

AUDIO PERFORMANCE - To minimise the effect of earth (ground) loops which result in audible Hum and buzz, and to shield the audio signals from interference.

For safety it is important that all equipment earths are connected to mains earth so that exposed metal parts are prevented from carrying high voltage which can injure or even kill

the operator.

It is recommended that a qualified system engineer check the continuity of the safety earth from all points in the system including microphone bodies, turntable chassis, equipment cases, and so on.

The same earth is also used to shield audio cables from external interference such as the hum fields associated with power transformers, lighting dimmer buzz, and computer radiation. Problems arise when the signal sees more than one path to mains earth. An 'earth loop' (ground loop) results causing current to flow between the different earth paths. This condition is usually detected as a mains frequency audible hum or buzz.

To ensure safe and trouble-free operation we recommend the following:

Have your mains system checked by a qualified electrician. If the supply earthing is solid to start with you are less likely to experience problems.

DO NOT remove the earth connection from the console mains plug. The console chassis is connected to mains earth through the power cable to ensure your safety. Audio 0V is connected to the console chassis internally. If problems are encountered with earth loops operate the audio 'ground lift' switches on connected equipment accordingly, or disconnect the cable screens at one end, usually at the destination.

Make sure that turntables are correctly earthed. A chassis earth terminal is provided on the console rear panel to connect to turntable earth straps.

Use low impedance sources such as microphones and line level equipment rated at 200 ohms or less to reduce susceptibility to interference. The console outputs are designed to operate at very low impedance to minimise interference problems.

Use balanced connections for microphones and mix output as these provide further immunity by cancelling out interference that may be picked up on long cable runs. To connect an unbalanced source to a balanced console input, link the cold input (XLR pin 3 or jack ring) to 0V earth (XLR pin 1 or jack sleeve) at the console. To connect a balanced XLR output to unbalanced equipment, link the cold output to 0V earth at the console.

Use superior quality cables and connectors and check for correct wiring and reliable solder joints. Allow sufficient cable loop to prevent damage through stretching.

If you are not sure...

Please contact your local Allen & Heath service agent or distributor for advice: www.allen-heath.com