



# ANX4

## Scalable Wireless Receiver

Manual for the Shure ANX4 scalable wireless receiver, compatible with ULX-D and Axient Digital transmitters. Includes how to activate and manage channel licenses, information about ULX-D and Axient Digital menus and transmission modes, and more.

Version: 2.1 (2025-J)

# Table of Contents

<b>ANX4 Scalable Wireless Receiver</b>	<b>4</b>	Antenna Bias	33
		Quadversity™ (Axient® Digital only)	33
<b>ANX4 Overview</b>	<b>4</b>	<b>Audio Settings</b>	<b>34</b>
Compatible Devices	4	Adjust Channel Gain	34
<b>What's in the Box</b>	<b>5</b>	Update Audio Output	34
<b>Get Started with ANX4</b>	<b>5</b>	Tone Generator	35
How Channel Licenses Work	5	Headphone Monitoring	35
Prepare Your Device to Connect	6	Dante Browse	35
Apply licenses to the ANX4	6	Dante Device Lock	36
Select a Transmission Mode on the ANX4	8	Dante Domain Manager	36
Set Antenna Bands	9	<b>Operation</b>	<b>36</b>
Find and Assign Frequencies to your Devices	9	Assign a Device ID	36
<b>Mounting Instructions</b>	<b>11</b>	Assign a Channel Name	36
<b>Front and Back Panel</b>	<b>11</b>	Update Number of Displayed Channels	36
<b>Home Display, Navigation, and Menus</b>	<b>13</b>	Device Locks and Access Control	38
Channel Information	14	License Status and Limits	38
Navigation and Controls	14	Factory Reset	38
Icons	15	Device Redundancy	39
Menu Structure	17	<b>Manage Licenses</b>	<b>40</b>
<b>Radio Frequency (RF) Settings</b>	<b>27</b>	Update License Count	40
Transmission Modes	27	Move Licenses Between Your Own Devices	41
Antenna Configuration	28	Move Licenses Between License Groups	41
What are Groups and Channels?	29	Deactivate a Device	41
Transmitter Sync Presets	29	Transfer Channel Licenses	42
Manually Set a Frequency	29	Add Channel Licenses via Claim Code	42
Request a New Frequency from a Spectrum Manager	30	<b>Firmware Updates</b>	<b>44</b>
Registered Transmitters in Transmitter Slots (Axient® Digital Only)	30	Firmware Versions	44
Interference Management	30	Update Firmware in ShureCloud	44
Frequency Diversity	31	Update Firmware in Shure Update Utility	45
		Update the Transmitter Firmware	45

<b>ANX4 DC Power Module</b>	<b>46</b>	<b>Receiver Frequency Bands</b>	<b>56</b>
Power Connections	46	ULX-D® Mode	56
Monitoring the DC Power Status	46	Axient® Digital Mode	58
Connector Wiring Diagram DC to 4-Pin XLR	47		
<b>Networking</b>	<b>47</b>	<b>Safety and Regulatory Information for Wireless Products</b>	<b>60</b>
Guided Network Configuration	47	Important Note	60
Network Services	49	Explanation of Symbols	60
Access the Network with a Computer	49	Important Safety Instructions	60
Connecting Receivers	49	<b>Important Product Regulatory Information</b>	<b>61</b>
Network Troubleshooting	50	Regulatory Information for Class B EMC Products	62
<b>Troubleshooting</b>	<b>50</b>	Regulatory Information for Wireless Products	64
Radio Frequency (RF) Troubleshooting Steps	52	Environmental Regulatory Information	65
<b>Contact Customer Support</b>	<b>53</b>	<b>Certifications</b>	<b>66</b>
<b>Specifications</b>	<b>53</b>	Regulatory Model Number (RMN)	66
		Certification and Compliance Markings	66

# ANX4

## Scalable Wireless Receiver

### ANX4 Overview

The ultimate high-tier, high-channel count wireless receiver, Shure ANX4 receives up to 16 channels of Shure Axient® Digital or 24 channels of Shure ULX-D® in a single rack space.

Delivering maximum flexibility, ANX4 does not ship preconfigured with active wireless channels but allows you to purchase channels in single- and four-channel increments and activate the exact number of channels you need\*. Purchase ANX4 channel licenses through the same authorized suppliers ANX4 hardware units are sold (or at [shure.com](https://www.shure.com)) and manage them via your ShureCloud user account.

Whether you operate ANX4 in Axient Digital or ULX-D transmission mode, ANX4 maximizes your budget, rack space, and antenna configuration.

Shure ANX4. Scalable wireless that adapts to your needs.

#### Features\*\*:

- Scalable wireless receiver for use with Axient® Digital and ULX-D® wireless systems
- Receives up to 16 channels of Axient® Digital or 24 channels of ULX-D® in a single rack space
- Channel licenses are available in single- and four-channel options (sold separately)\*
- Wide tuning range covers 174 MHz to 2 GHz, covering all Axient® Digital and ULX-D® options (except for the ULX-D 902 to 928 MHz band)
- Large, 6.6-inch front panel color display
- ¼-inch front-panel headphone connector for monitoring with Dante Browse (for both Axient® Digital and ULX-D®)
- Streamlined, cost-saving antenna setup for large-scale wireless deployments
- 4 x Ethernet ports for network control and Dante/AES67 digital output options
- 4 x coaxial RF antenna input connectors support multiple frequency bands and provide greater coverage for complex setups
- Networked control with Shure Wireless Workbench for extended and enhanced RF monitoring and management
- DC module version available to support redundant power

\*ANX4 receiver does not ship preconfigured with active wireless channels. Channel licenses are sold separately and required for operation.

\*\*System features are dependent upon activated transmission mode: Axient Digital or ULX-D (ANX4 does not support both systems, or both system features, at the same time).

### Compatible Devices

The ANX4 is compatible with all ULX-D® and Axient® Digital transmitters.

Optionally, use with:

- AD600 Spectrum Manager for frequency coordination and management
- AD610 Diversity ShowLink® access point to enable ADX-series transmitter linking and remote control
- All Axient® Digital and ULX-D® receivers - The ANX4 can deploy group scan results to these receivers
- Shure applications, including:
  - Wireless Workbench: [shure.com/WWB](https://www.shure.com/WWB)
  - Shure Update Utility: [shure.com/shure\\_update\\_utility](https://www.shure.com/shure_update_utility)

- ShureCloud: [cloud.shure.com](https://cloud.shure.com)

---

## What's in the Box

- ANX4
- BNC coax cables (x2) - 95C9023
- Bulkhead adapter - 95A8994
- Ethernet cables (x2, short and long)
- Rack mount hardware kit - RPW503
- For some configurations, power cable with V-Lock

---

## Get Started with ANX4

Configure the ANX4 to fit your needs with scalable cloud-based channel licenses, wideband tuning, and selectable transmission modes.

What you'll need:

- ANX4
- Network with internet access for ANX4
- Computer or another device to access ShureCloud

The ANX4 receiver does not ship with active wireless channels. Out of the box, it displays 8 unlicensed channels. Channel licenses are sold separately and are required for operation.

**Important:** An unlicensed channel does not pass audio. In order to pass audio, purchase licenses and activate them in ShureCloud.

Overview of setup steps:

1. **Purchase channel licenses:** Purchase channel licenses through the authorized supplier your hardware unit came from, or visit [shure.com/anx4](https://shure.com/anx4).
2. **Prepare the ANX4 to connect:** Enable cloud connectivity and connect to the internet.
3. **Activate channel licenses:** Claim the ANX4 in ShureCloud and activate channel licenses.
4. **Select a transmission mode on the ANX4:** Set the ANX4 to work with either Axient Digital or ULX-D portable devices.
5. **Set up the ANX4 for use:** Configure antennas and find frequencies for your channels.

Each of these steps is covered in more detail below.

ANX4 channel licenses are subject to the Channel License Agreement available at <https://www.shure.com/en-US/legal>.

A ShureCloud account is required to activate and manage channel licenses. For more information, see the [ShureCloud User Guide](#) and Cloud Terms of Use available at <https://www.shure.com/en-US/legal>.

## How Channel Licenses Work

This device uses channel licenses to determine how many audio channels are available. Basic information about channel licenses:

- Buy a license for every channel of audio you want to pass through the device.

*Note: Some devices ship with already-licensed channels, while other devices ship without licensed channels and require license purchase and activation to pass audio.*

- Channel licenses are available in 1- and 4- channel configurations.
- Channel licenses are perpetual and do not expire. See the Channel License Agreement, available at <https://www.shure.com/en-US/legal>, for full license terms.
- Each channel license can only be attributed to one device at a time.
- Channel licenses can be activated and later moved to be re-used across different units that you own.
- Once channel licenses are activated on your device, you do not need to maintain an internet connection to use the device or its licensed channels.

## Purchase Channel Licenses

To buy channel licenses, contact the authorized supplier your hardware unit came from, or visit the [shure.com](https://www.shure.com) product page for your device.

## Get Started with ShureCloud

Go to [cloud.shure.com](https://cloud.shure.com) to sign in or create a [My Shure ID account](#).

**Accounts for organizations:** Have the person who will serve as an organization admin fill out the contact form. Organization admins invite others and manage user accounts for the organization.

## Prepare Your Device to Connect

To add a device to ShureCloud, connect it to the internet and enable cloud connectivity.

1. Connect your device to a network with internet access, either directly via Ethernet cable or through an Ethernet switch.
2. Confirm that your device and computer are connected to the same network: Device Configuration > Network Configuration. For more detail on network setup, see Networking.
3. Verify that cloud connectivity is enabled on your device: Device Configuration > Network Services.

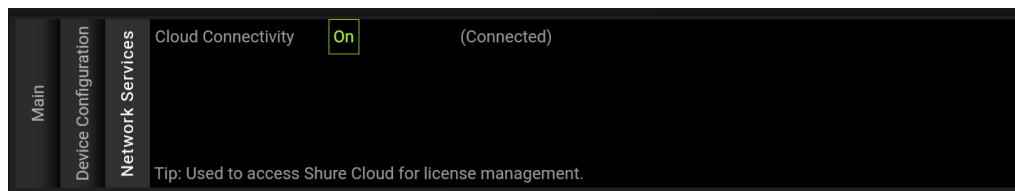

4. Optionally, name your device (Device Configuration > Device ID or in Wireless Workbench) to make it easier to find in ShureCloud.

## Apply licenses to the ANX4

Once a device is online with cloud connectivity enabled, log in to your [ShureCloud account](#) to add your device to ShureCloud and activate licenses.

## Add Devices

To manage devices in ShureCloud, add them to your Devices list (ShureCloud > Devices).

### To add devices, you will need:

- Cloud connectivity turned on for all devices
  - [Learn how to turn on cloud connectivity.](#)
- Device MAC addresses and serial numbers for methods 1 or 2
  - Most devices use the Shure control MAC address to connect. The IntelliMix™ Foundation Compute uses the MAC address printed on the bottom of the unit.
  - [Learn how to find a device's MAC address.](#)

There are 3 ways to discover compatible devices. Click + Add devices on the Devices tab and choose from the following methods:

## Method 1: Upload CSV with MAC Addresses and Serial Numbers

Add multiple devices using the appropriate MAC addresses and serial numbers. On the ANX4 and ATDQ/ADTD, the MAC address and serial number are listed in the License Status menu (Device Configuration > License Status).

1. Click + Add devices.
2. Create and upload your CSV.

**Tip:** Download the provided template file to avoid formatting errors.

3. Click Claim (x) devices.
4. Devices are added to the Pending list, and automatically move to the Devices list once an active internet connection is confirmed.
5. Refresh the page and verify your devices appear in the Devices list. A green box indicates that a device is online.

## Method 2: Add a Single Device

Add devices connected to any network by entering the appropriate MAC address and serial number.

1. Click + Add devices.
2. Enter a valid MAC address and device serial number to add a single device.

**Note:** On the ANX4 and ADTD/ADTQ, the MAC address and serial number are listed in the License Status menu (Device Configuration > License Status).

3. Click Claim 1 device.
4. Your device is added to the Pending list, and automatically moves to the Devices list once an active internet connection is confirmed.
5. Refresh the page and verify your devices appear in the Devices list. A green box indicates that a device is online.

## Method 3: Scan Local Network for Devices

Add devices connected to your local network by scanning the network and selecting from a list of available devices on the same subnet as your computer.

1. Click + Add devices > Scan local network for devices.
2. Select the devices from the list and click Claim (x) devices. Because cloud connectivity is enabled and an internet connection is established, devices are automatically added to the Devices list.
3. Refresh the page and verify your devices appear in the Devices list. A green box indicates that a device is online.

**Tip:** If a device gets stuck in the Pending list and you have entered the correct information, try turning off the device's cloud connectivity setting and turning it back on. This triggers ShureCloud to look for the device again.

## Activate Licenses

Activate channel licenses in the ShureCloud Licenses tab.

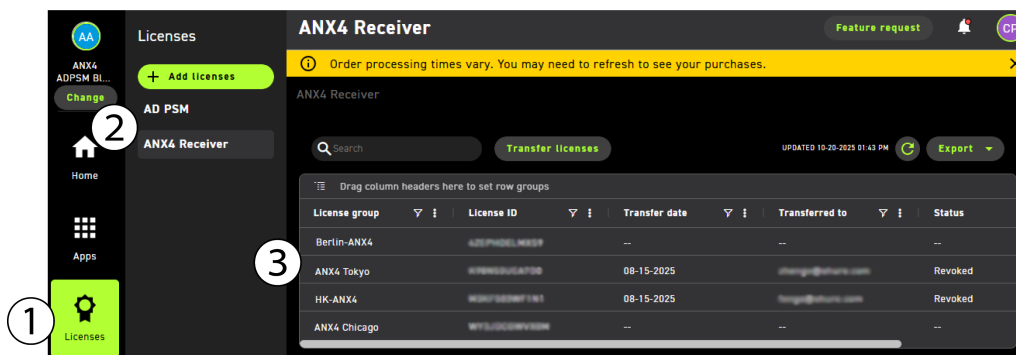

1. From the [ShureCloud home page](#), click Licenses.

**Note:** To add licenses you've received a claim code for, refer to [Add Channel Licenses via Claim Code](#).

2. Select the appropriate device type. Channel licenses can only be used on the device types for which they were purchased (channel licenses for ANX4 devices cannot be used for Axient® Digital PSM® devices, etc.)
3. Double-click your license group.

**Note:** License groups are collections of licenses purchased at the same time.

4. In the Details pane, view the remaining, activated, and total licenses for this license group. Click Activate devices and select your device.
5. In the dropdown menu, choose the number of channels to add to the device.
6. Click Next and follow the prompts to activate your channel licenses.
7. The device reboots to apply the licenses. The reboot takes 45 seconds to 1 minute.

Verify that your licenses appear on your device by going to Device Configuration > License Status. Once licenses are applied, devices do not need to maintain an internet connection to stay licensed. Disconnect and turn off cloud connectivity until license updates are needed.

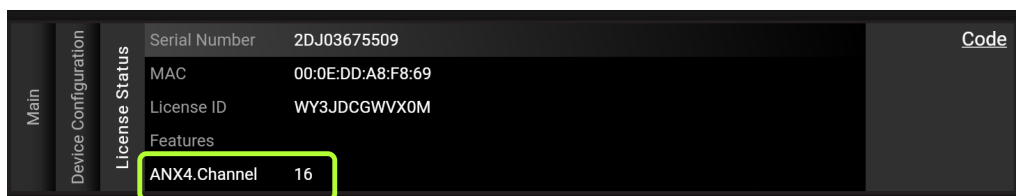

An ANX4 with 16 channel licenses activated

## Select a Transmission Mode on the ANX4

Set the transmission mode on the ANX4 to match your transmitter and frequency needs. The ANX4 operates in one of 4 transmission modes:

- ULX-D Standard
- ULX-D High Density
- Axient Digital Standard
- Axient Digital High Density

Refer to the [Transmission Modes](#) topic for more information about each mode.

To change the transmission mode:

1. From the Device Configuration menu: Device RF > Transmission Mode.
2. Use the control wheel to select a mode.
3. Press ENTER to reboot and apply the change.

The transmission mode appears in the upper right corner of the display and in the channel tile.

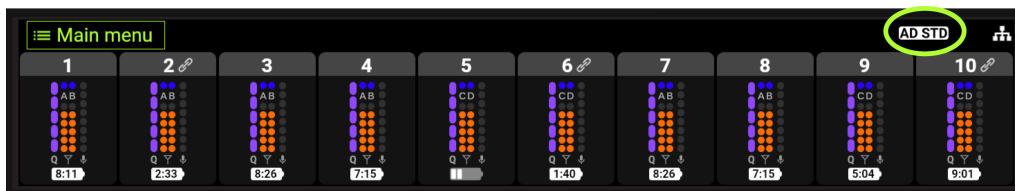

ANX4 in AD STD (Axient Digital Standard) transmission mode

## Set Antenna Bands

The ANX4 has 4 antenna ports to support multiple frequency bands and provide greater coverage for complex systems. Each antenna pair on the ANX4 has a tuning range of 72 MHz. Antenna pairs can be set to different bands or different parts of the same wide tuning band to cover more than 72 MHz.

1. Connect your antennas to the receiver.
2. Set up antenna bands: Go to Main menu > Device Configuration > Device RF > Antenna Configuration and select an antenna band for antenna pairs AB and CD.

**Note:** If an RF band is wider than the tuning range of a single pair of antennas, the tuning range is adjustable. Optionally, set one or both antennas to cover a subset of the band. When assigning antenna bands to channels, select Auto to support a channel with a combination of AB and CD.

For more information, refer to [Antenna Configuration](#).

## Find and Assign Frequencies to your Devices

To prepare for a show, assign RF bands to your channels, scan for clear frequencies, and perform an IR sync.

### Assign RF Bands to Channels

Select an RF band to support each channel.

1. Use the control wheel to open a channel menu and navigate to RF Band.
2. Select an RF band. Available bands are determined by your antenna configuration. Select Auto to cover bands wider than 72 MHz with a combination of AB and CD.
3. Press ENTER to save your band selection.
4. Press Next and Previous to move between channels.

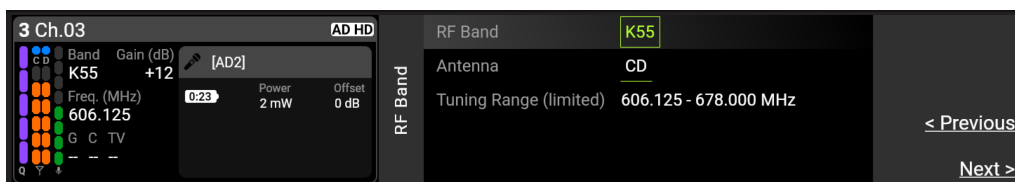

## Scan for Available Frequencies

Scan individual channels to find available frequencies, or scan an entire group to find the most available frequencies. Refer to [What are Groups and Channels?](#) for more information.

**Important:** Before scanning, turn your transmitters off to prevent them from interfering with the scan, and turn on any potential sources of disruption (other wireless systems, computers, large LED panels, effects processors) so the scan can detect and avoid the interference they generate.

### Group scan

Group scan automatically finds all available frequencies within a group. Available frequencies can be automatically deployed to receiver channels and other networked components.

1. Select a channel and go to Group Scan.
2. Press Start to scan the group.
3. When the scan is complete, the number of frequencies found appear on the display.
4. Select Deploy.

### Channel scan

Channel scan automatically scans a group to find available frequencies.

1. Select a channel and go to Channel Scan.
2. Use the control wheel to choose a group to scan.
3. Select Scan to find open frequencies in the selected group.

*Note: Open channels are sorted from lowest RSSI (best match) to highest RSSI. Use the control wheel to scroll through frequency options.*

4. Press ENTER to confirm your frequency selection.

## Perform an IR sync

Form an audio channel between transmitter and receiver with IR sync.

**Note:** In order to sync, the receiver band the transmitter band must match.

1. Select a receiver channel.
2. Make sure the channel is tuned to an available frequency.
3. Power on the transmitter.
4. Press SYNC on the receiver.
5. Align the IR windows until the receiver IR sync LED illuminates red. When complete, a success message appears. The transmitter and receiver are now tuned to the same frequency.

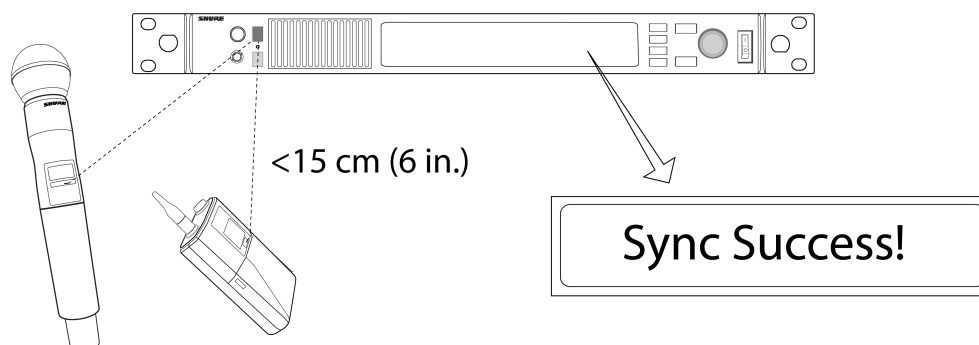

**Note:** Any change to the encryption status on the receiver (enabling or disabling encryption, requesting a new encryption key) requires a sync to send the settings to the transmitter.

# Mounting Instructions

This component is designed to fit into an audio rack.

Warning: To prevent injury this apparatus must be securely attached to the rack.

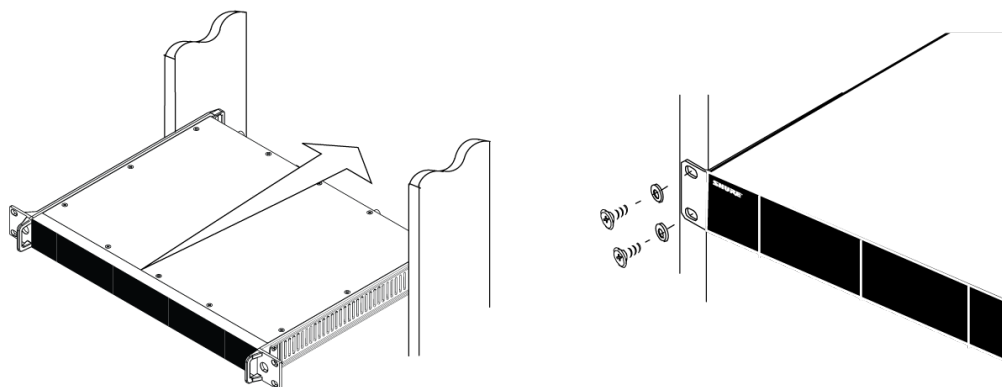

# Front and Back Panel

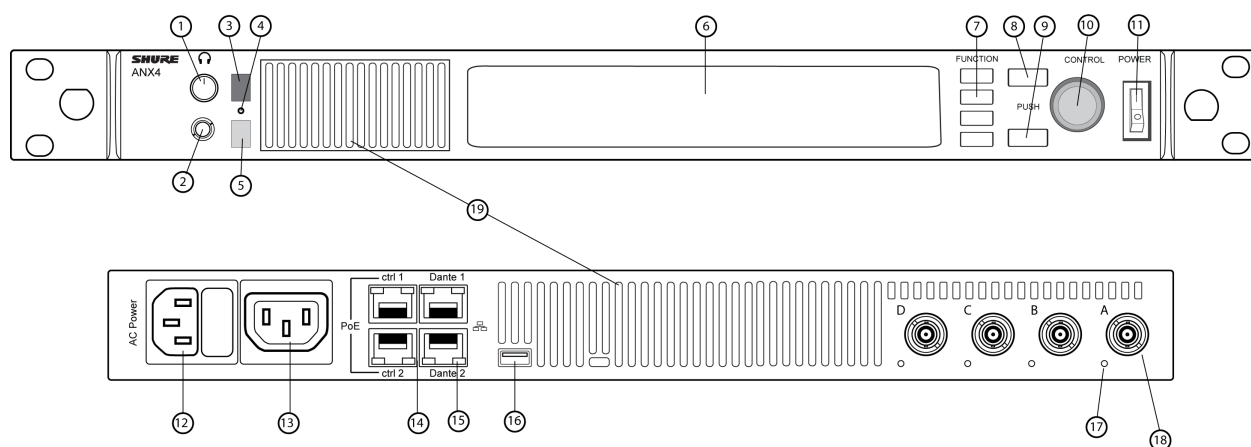

## ① Headphone volume knob

Controls headphone volume. Clip indicator warns of signal overload. Press knob to see headphone settings.

## ② Monitor jack

¼" (6.35 mm) audio output jack.

## ③ IR sync window

---

Align with IR window on transmitter to sync.

#### ④ IR sync LED

The LED will turn red when the transmitter and receiver are correctly aligned for IR sync.

#### ⑤ Ambient light sensor

Automatically detects external lighting conditions.

#### ⑥ Display

Shows channel information.

#### ⑦ Function buttons

Press to access editing and configuration options. The buttons are named F1, F2, F3, F4 (from top to bottom) and illuminate when options are available.

#### ⑧ ENTER button

Press to save changes.

#### ⑨ EXIT button

Press to cancel changes and return to previous menus.

#### ⑩ Control wheel

- Push to access a menu
- Push to select parameters or menu items
- Turn to scroll through menu items or to edit a parameter value

#### ⑪ Power switch

Powers the unit on or off.

#### ⑫ AC power input

IEC locking connector, 100-240 V AC.

#### ⑬ AC power cascade (locking)

Use IEC extension cables to cascade power through multiple devices.

**Note:** DC module - back panel has DC input instead.

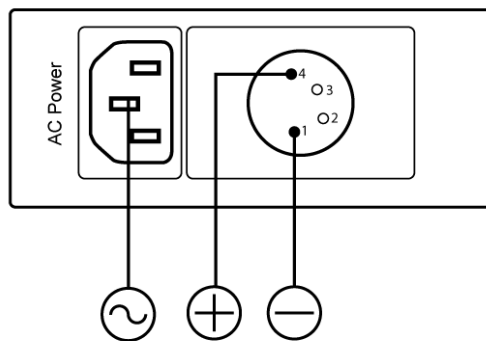

## 14 Ethernet ports

Four Ethernet ports carry the following signals when in Split/Redundant mode:

- ctrl 1: Network control; supports PoE
- ctrl 2: Network control; supports PoE
- Dante primary: Dante digital audio
- Dante secondary: Dante digital audio

*Note: The receiver can only power 1 PoE device at a time.*

## 15 Network status LEDs

- Off: No network link
- Green (on or flashing): Network activity detected on the port
- Amber: Indicates network speed
  - Off when port is operating at network speeds of 10/100 Mbps
  - On when port is operating at network speeds of 1 Gbps

## 16 USB port

For factory use.

## 17 RF/Antenna status LED (one per antenna)

- Green: Antenna bias on
- Red: Antenna fault
- Off: Antenna bias off

## 18 Coaxial inputs for antennas A, B, C, D

RF connection for antennas A, B, C, D.

## 19 Cooling vents

Vents on the front and rear for cooling.

---

# Home Display, Navigation, and Menus

See a high level overview of device and channel properties at a glance on the home display.

Device properties, like transmission mode, lock status, and network status, appear in the top right corner of the screen.

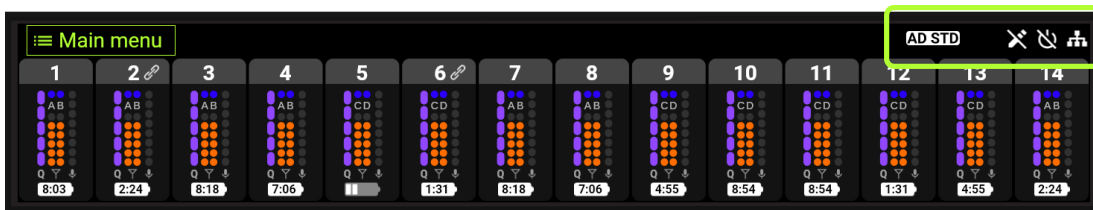

The channel display scales along with the channel count to show more or less detail about each channel. Refer to [Update Number of Displayed Channels](#) for more detail on the displayed channel count.

## Channel Information

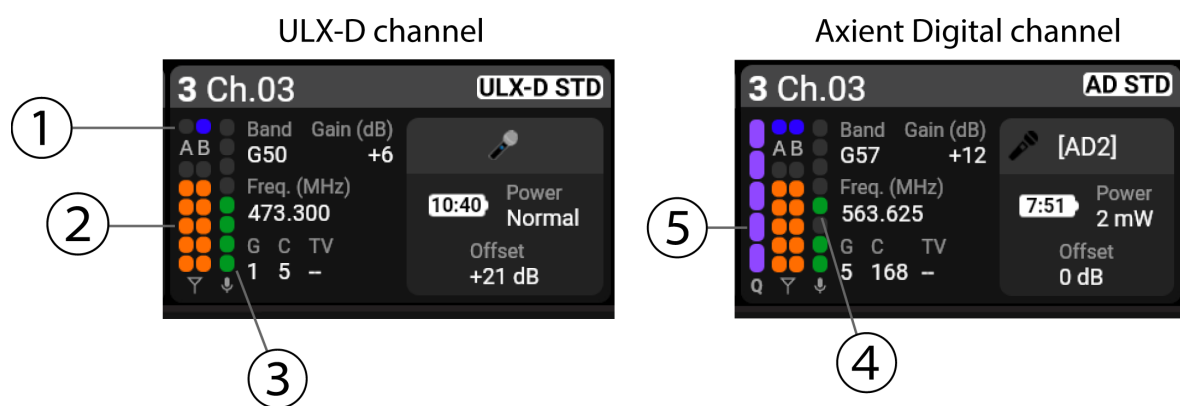

- Antenna status LEDs:** Indicate which antennas (AB/CD) support this channel.
  - Off: No signal
  - Blue: Antenna(s) being used for signal
  - Red: Interference occurring
- Signal strength meter:** Displays signal strength of each antenna for this channel.
  - Orange: Signal strength indicator
  - Red: RF power overload
- Audio meter:** Indicates audio signal strength (RMS).
  - Green: -54 to -19 dBFS
  - Yellow: -18 to -6 dBFS
  - Red: Audio overload
- Peak signal strength indicator:** LED at peak audio signal lingers as audio meter rises and falls with current RMS.
- Channel quality meter (Axient® Digital only):** Displays signal-to-noise ratio of RF signal. If the noise ratio increases, the quality meter decreases. Low levels of channel quality provide an early warning of potential problems, allowing you to switch to a clear frequency.

## Navigation and Controls

Use the function buttons, control wheel, ENTER, and EXIT to navigate to menu choices and to set parameters.

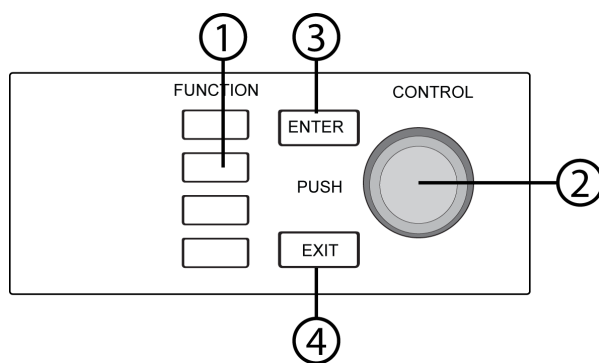

## ① Function buttons

Press to access editing and configuration options. The buttons are named F1, F2, F3, F4 (from top to bottom) and illuminate when editing options are available.

## ② Control wheel

- Push to enter a menu
- Push to select a menu item
- Turn to scroll through menu options or to edit a parameter

## ③ ENTER

Press to confirm or save changes.



















## ④ EXIT

Press to cancel changes and return to the previous menu.

## Icons

The following screen icons indicate device or channel modes and settings.

Device or channel	Icon	Description
Device icons	ULX-D STD	ULX-D standard transmission mode
	ULX-D HD	ULX-D high density transmission mode
	AD STD	Axient Digital standard transmission mode
	AD HD	Axient Digital high density transmission mode
		Front panel lock: Prevents menu changes.
		Power switch lock: Prevents accidental shutoff. When the power lock is activated and the power switch is toggled, the ANX4 remains on.

Device or channel	Icon	Description
		Network status indicator: Appears if the ANX4 sees other devices on the network.
		Network access control is on
		Power source AC, DC power not available
		Power source AC, DC power available
		Power source DC
		Device alert: Select the icon to learn more.
		Device redundancy: Primary device, redundant device online
		Device redundancy: Primary device, redundant device offline
		Device redundancy: Primary device, peer error
		Device redundancy: Redundant device, in sync with primary
		Device redundancy: Redundant device, syncing
		Device redundancy: Redundant device, primary offline
		Device redundancy: Redundant device, peer error
<b>Channel icons</b>		RF is transmitting (no icon - RF mute is on for this channel).
		ShowLink quality meter: Indicates ShowLink control between the receiver and the linked transmitter. Number of bars indicates ShowLink connection strength.
		A device or channel link exists
		Encryption is on for this channel
		Remote portable lock is on (power, menu, or all)
		High pass filter is on for transmitter

Device or channel	Icon	Description
	FD-C	Frequency diversity combining mode activated for this channel
	FD-S	Frequency diversity selection mode activated for this channel
	Y Y Y Y	Quadiversity activated for this channel

## Menu Structure

**Device Configuration menu:** The ANX4 device configuration menu contains device-level settings that apply across channels. From the main display, select Main Menu > Device Configuration to access device settings.

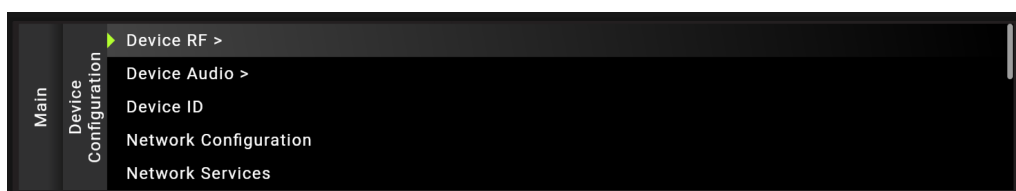

**Channel menus:** Select a channel with the control wheel to see and edit channel details. Details and options vary for ULX-D and Axient Digital transmitters.

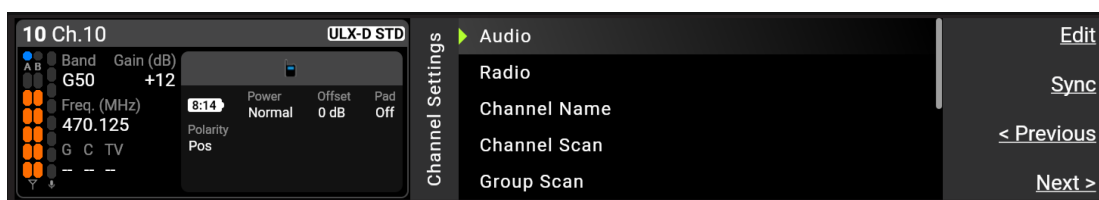

ULX-D channel menu

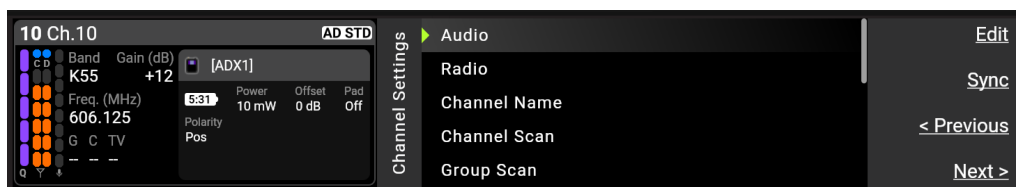

Axient Digital channel menu

From the detailed channel view, use the function buttons to quickly edit channel details, perform an IR sync, and move between channels, or use the control wheel to navigate through the channel menu.

**Headphone menu:** View and adjust headphone channel selection and limiter thresholds. Press the headphone knob or go to Device Configuration > Headphone Monitor to open the headphone menu.

## Device Configuration Menu Map

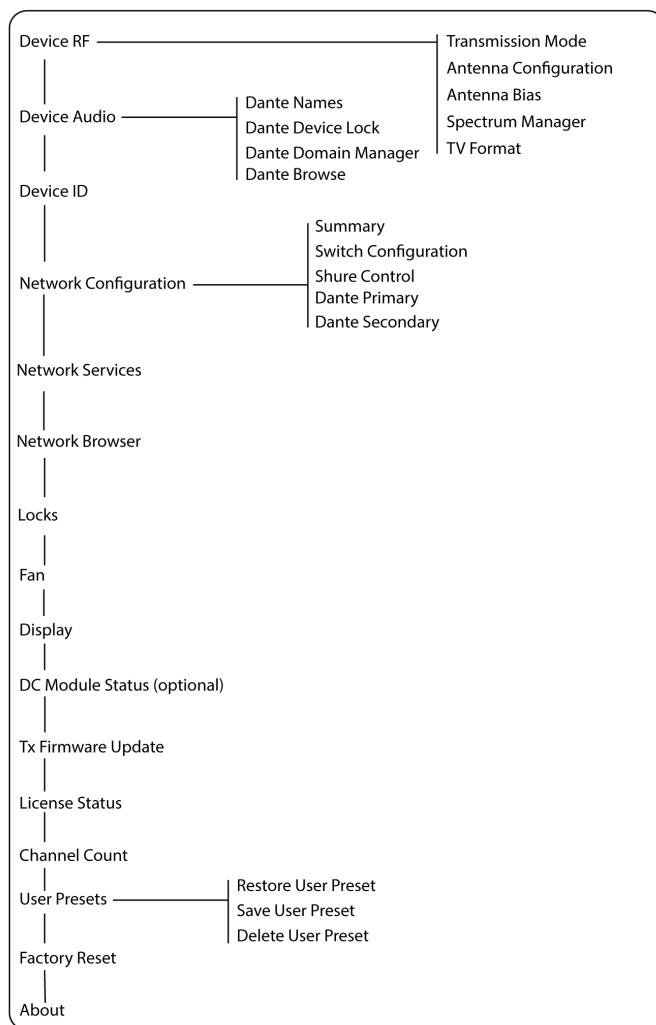

## Device Configuration Parameters

Use these parameters to adjust device settings.

### Device RF

#### Transmission Mode

Select a transmission mode to operate the ANX4 with ULX-D® or Axient® Digital transmitters. For more information, refer to [Transmission Modes](#).

#### Antenna Configuration

Select an RF band and see or edit the tuning range for each pair of antennas. For more information, refer to [Antenna Configuration](#).

#### Antenna Bias

Enable antenna bias for active RF antennas.

#### Spectrum Manager

---

Select a Spectrum Manager to connect to the receiver and see status information for the applied Spectrum Manager.

### **TV Format**

Adjust TV bandwidth to match regional standards.

### **Custom Groups**

See and configure custom groups.

## **Device Audio**

### **Dante Names**

View, edit, and copy names for networked Dante components.

### **Dante Lock Status**

See the status of the Dante device lock.

### **Dante Domain Manager**

See the status of Dante Domain Manager settings.

### **Dante Browse**

See a full list of devices discovered on the Dante network.

## **Device ID**

Use the control wheel to assign or edit an ID. Assigning custom names or IDs helps with monitoring and organization when the receiver is part of a large system.

## **Network Configuration**

Configure IP, network, and Dante settings. Press F1 to set up your network and F4 to see more network details. For detailed network setup steps, refer to [Networking](#).

### **Summary**

See a summary of network information

### **Switch Configuration**

- Split/Redundant
- Switched

### **Shure Control**

Current Shure Control IP address

### **Dante Primary**

Current Dante Primary IP address

### **Dante Secondary**

Current Dante Secondary IP address. Only appears if switch is configured to split/redundant.

---

## Network Services

Turn network services on or off, including cloud connectivity and third-party API control.

## Network Browser

Use the Network Browser utility to view Shure devices on the network.

**Tip:** Press the control wheel to see the device IDs, IP addresses, and firmware versions of each device.

### Identify All

Flashes the front panel of all devices on the network.

### Refresh

Updates the device list.

### F.W. Version

Displays the installed firmware version of devices found on the network. Select Model to view the device model.

## Locks

Use locks to prevent accidental or unauthorized changes to controls and settings.

### Power Lock

Unlocked or locked

### Front Panel Lock

Unlocked or locked

### Access Control

Enabled or disabled. Use Wireless Workbench or other Shure control software to enable or disable Access Control.

## Fan

### Fan Mode

- Auto: Fan automatically turns on to regulate device temperature
- On: Runs continuously to offer maximum cooling in warm environments

### Temperature

Displays internal receiver temperature.

## Display

### Brightness

Adjust the brightness of the display.

### Display Sleep

Offers options to turn off display and front panel illumination after 10, 30, or 60 seconds.

**Tip:** Press any front panel button to interrupt display sleep.

---

## DC Module Status (optional)

Displays operational status of the DC Module (if installed).

## Tx Firmware Update

Hosted firmware shows latest transmitter firmware downloaded onto receiver (AD or ULX-D). Refer to [Firmware Updates](#) for more information.

## License Status

Displays serial number, MAC address, and number of licenses activated on this device. Add or modify a license limit or license limit code. Refer to [License Status and Limits](#) for more information.

## Channel Count

Choose to limit the channels visible on the device front panel and control applications. Regardless of how many channels you choose to display, only licensed channels are operational. For more information, refer to [Update Number of Displayed Channels](#).

## User Presets

Create and manage presets for quick receiver configuration. Up to 4 presets can be stored in receiver memory.

- Restore User Preset: Load existing preset
- Save User Preset: Save the current settings as a preset
- Delete User Preset: Delete a preset

## Device Redundancy

Designate a backup ANX4 in case of emergency. Refer to [Device Redundancy](#) for more information.

## Factory Reset

Restores all receiver parameters to factory settings.

## About

Provides a detailed list of build specifications and vital statistics for the receiver.

## ULX-D Channel Menu Map

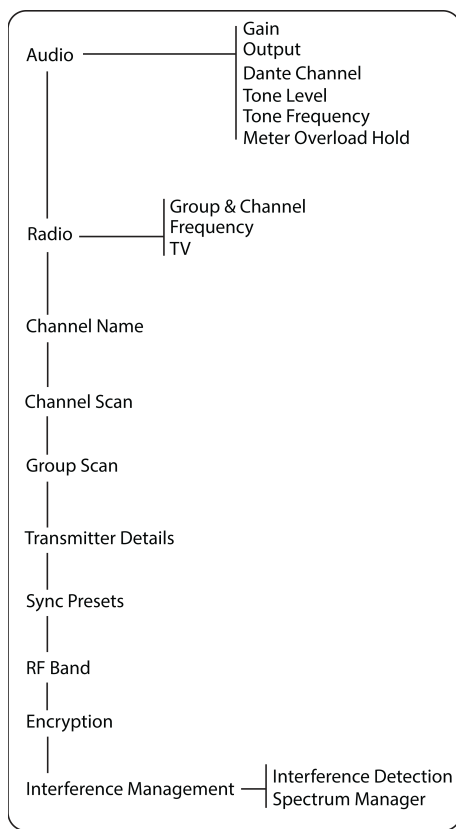

## ULX-D Channel Menu Parameters

Use the Previous and Next buttons to navigate between menu items.

### Audio

#### Gain

Adjust the gain in 1 dB increments.

#### Output

Select On or Mute for the receiver audio output.

#### Dante Channel

Displays the channel label in Dante.

#### Tone Level

Turn on and adjust the level of the tone generator, a continuous audio signal tone for testing and troubleshooting.

#### Tone Frequency

Adjust the frequency of the tone generator.

#### Meter Overload Hold

Enable overload hold to capture signal peaks.

- Clear Clip: Clear a single clip when meter overload hold is on.
- Clear All Clip: Media overload hold clear for all channels.

## Radio

If you are using a Spectrum Manager as a frequency server, the function buttons appear as New Freq. in this menu. For more information, refer to [Request a New Frequency from a Spectrum Manager](#).

### G & C (Group & Channel)

Assign a frequency group and channel. Refer to [What are Groups and Channels?](#) for more information.

### Frequency

Manually select a frequency. Unplanned frequencies are marked with an asterisk.

### TV

Displays the TV band for the selected frequency.

## Channel Name

Use the control wheel to assign or edit the channel name. Assigning unique names to each channel helps with identification and organization when the receiver is part of a large system.

## Channel Scan

Press Scan to find available channels within the selected group. Produces detailed list of available frequencies in order of lowest RF noise floor.

## Group Scan

Scans the selected group to find all available channels.

## Transmitter Details

Displays build details and vital statistics for the selected transmitter. This information is transmitter-specific, but might include:

- Device model
- Device ID
- RF power
- Menu lock
- Power lock
- Battery information
- LED brightness options
- Firmware version

## Sync Presets

Choose what information to transmit during an IR sync.

## RF Band

### RF Band

Choose an RF band for this channel.

### Antenna

Populates based on antenna configuration and selected RF band. "Auto" indicates that a mix of AB and CD is necessary to support the channel.

### Tuning Range

The tuning range of the selected RF band. "Limited" indicates that the tuning range does not cover the full range of the chosen RF band.

## Encryption

Turn encryption mode on or off and, if needed, regenerate the encryption key. Options:

- Off
- On (Auto)
- On (Manual)

## Interference Management

Select an interference detection setting for the channel.

## Axient Digital Channel Menu Map

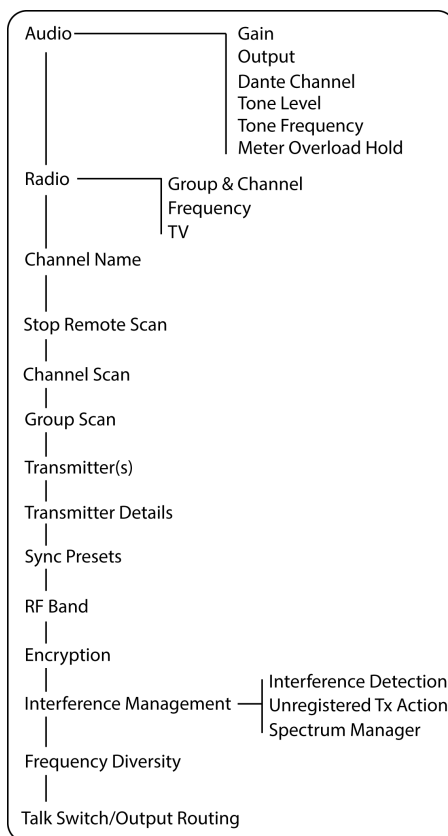

## Axient Digital Channel Menu Parameters

Press Previous and Next to navigate between menu items.

### Audio

#### Gain

Adjust the gain in 1 dB increments.

### **Output**

Select On or Mute for the receiver audio output.

### **Dante Channel**

Displays the channel label in Dante.

### **Dante Channel Alternate**

Use for Talk Switch optional routing.

### **Tone Level**

Turn on and adjust the level of the tone generator, a continuous audio signal tone for testing and troubleshooting.

### **Tone Frequency**

Adjust the frequency of the tone generator.

### **Meter Overload Hold**

Enable overload hold to capture signal peaks.

- Clear Clip: Clear a single clip when meter overload hold is on.
- Clear All Clip: Media overload hold clear for all channels.

## Radio

If you are using a Spectrum Manager as a frequency server, the function buttons will appear as New Freq. in this menu. For more information, refer to [Request a New Frequency from a Spectrum Manager](#).

### **G & C (Group & Channel)**

Assign a frequency group and channel. Refer to [What are Groups and Channels?](#) for more information.

### **Frequency**

Manually select a frequency. Unplanned frequencies are marked with an asterisk.

### **TV**

See the TV band for the selected frequency.

## Channel Name

Use the control wheel to assign or edit the channel name.

## Stop Remote Scan

Only appears if a remote scan is in progress.

---

## Channel Scan

Find available channels within the selected group. Produces detailed list of available frequencies in order of lowest RF noise floor.

## Group Scan

Scans the selected group to find all available channels.

## Transmitter(s)

Use the control wheel to assign and view transmitter slots. For more information, refer to [Registered Transmitters in Transmitter Slots](#).

### **Activate (ShowLink active transmitters)**

Mute all other ShowLink active transmitters.

### **Identify (ShowLink active transmitters)**

Flash the transmitter display.

### **Unlink**

Remove a transmitter from the selected slot.

### **Sync**

Assign a transmitter to the selected slot.

## Transmitter Adjust

Monitor and control active ShowLink transmitters. Transmitters must be on, in range, and linked to a ShowLink access point for remote control.

### **Identify**

Flash the transmitter display.

### **SL Test**

Open a ShowLink test for the transmitter.

## Transmitter Details

See build details and vital statistics for the selected transmitter. This information is transmitter-specific, but might include:

- Device model
- Device ID
- RF power
- Menu lock
- Power lock
- Battery information

## Sync Presets

Choose what information to transmit during an IR sync.

## RF Band

### RF Band

Choose an RF band for this channel.

### Antenna

Populates based on antenna configuration and selected RF band. "Auto" indicates that a mix of AB and CD is necessary to support the RF band. For more information, refer to [Antenna Configuration](#) or [Quadveristy](#).

### Tuning Range

The tuning range of the selected RF band. "Limited" indicates that the tuning range does not cover the full range of the chosen RF band.

## Encryption

Turn encryption on or off and, if needed, regenerate the encryption key.

## Interference Management

Select an interference detection setting, choose how the ANX4 reacts to unregistered transmitters, and assign a Spectrum Manager to the channel. Refer to [Interference Management](#) for more information.

## Frequency Diversity

Configure frequency diversity for handheld or bodypack transmitters. Refer to [Frequency Diversity](#) for more information.

## Talk Switch/Output Routing

Set receiver output signal routing options for talk switch control from a transmitter.

---

# Radio Frequency (RF) Settings

## Transmission Modes

On the ANX4, standard and high density transmission modes are available for both ULX-D® and Axient® Digital.

- Standard (STD) mode is ideal for situations where spectrum is not limited or when you need to operate transmitters at higher power levels to increase range.
- High density (HD) mode is ideal when you need many channels in a confined area, transmission distances are short, and you have limited channels available. Best practices for high density mode:
  - When band planning, position high density channels in a range of frequencies separated from other devices
  - Use a separate RF zone for high density channels to prevent intermodulation distortion from other devices and protect the lower-power HD channels
  - Don't misuse high-gain directional antennas

- Only use enough RF gain to compensate for cable losses
- Keep transmitters at least 10 feet from receiver antennas

## Select a Transmission Mode

1. From the Device Configuration menu: Device RF > Transmission Mode
2. Use the control wheel to select a mode.
  - **ULX-D Standard (ULX-D STD)**: Uses channel spacing that allows for the operation of ULX-D<sup>®</sup> transmitters at various power levels
  - **ULX-D High Density (ULX-D HD)**: Creates additional bandwidth for more channels in crowded RF environments by transmitting at 1 mW RF transmit power and narrowing the modulation bandwidth
  - **Axient Digital Standard (AD STD)**: Uses channel spacing that allows for the operation of Axient<sup>®</sup> Digital transmitters at various power levels.
  - **Axient Digital High Density (AD HD)**: Creates additional bandwidth for more channels in crowded RF environments by transmitting at 2 mW RF power and narrowing the modulation bandwidth.
3. Press ENTER to change the transmission mode and reboot the receiver. Perform frequency coordination and re-sync your transmitters after the receiver reboots.

## Antenna Configuration

The ANX4 has 4 antenna inputs. Each antenna pair (AB and CD) can be set to different RF bands to cover a wide range of frequencies. The Antenna Configuration menu (Device Configuration > Device RF > Antenna Configuration) shows the following information:

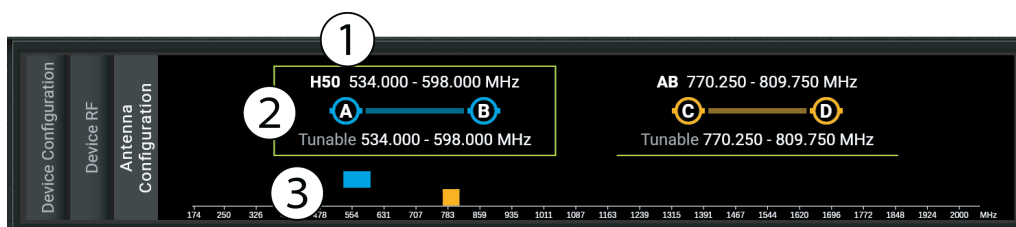

1. The bandwidth of the selected band for each antenna pair
2. The actual tuning range of each antenna pair
3. A color-coded visual representation of the spectrum covered by each antenna pair

## Set Antenna Bands

1. From the Device Configuration menu, go to Device RF > Antenna Configuration.
2. Use the control wheel to select an antenna pair and choose an RF band.
3. If the band is wider than 72 MHz: Optionally, adjust the tuning range.
4. Press ENTER to save.
5. As needed, assign antenna bands to each channel (Channel menu > RF Band) and coordinate frequencies. Select Auto to cover bands wider than 72 MHz with a combination of AB and CD.
6. Re-sync any portable devices linked to the receiver.

## Cover Bands Wider than 72 MHz

Some RF bands are wider than the 72 MHz tuning capability of a single antenna pair. When an antenna pair is set to one of these bands, the tuning range is adjustable.

To cover more of an RF band that is wider than 72 MHz:

1. Set both antenna pairs to the same band
2. Set the tuning range of each antenna pair to cover a different area of the spectrum within that band.
3. When you assign bands to each channel, select Auto to use a mix of AB and CD to cover the channel.

In the spectrum visualization, frequencies that are part of the selected band for an antenna pair but not covered by the antenna pair's tuning range appear dimmed. The info icon (circled) indicates that the tunable range of an antenna pair is less than the full band width.

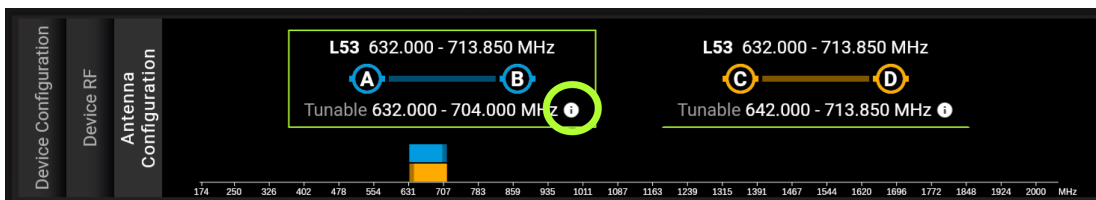

## What are Groups and Channels?

To minimize interference, Shure wireless systems organize RF bands into predefined **groups** and **channels**. Groups and channels are optional to use, and they can be helpful when you're coordinating frequencies without Wireless Workbench, AD600, or 3rd-party software.

- A **group** is a set of compatible frequencies within a frequency band.
- A single frequency within a group is a **channel**. Tune a receiver and transmitter to the best available channel within its group to set up your system.

**Note:** If your configuration involves multiple RF bands or product series, consider using tools like the AD600 and Wireless Workbench's frequency coordination for frequency planning.

## Transmitter Sync Presets

Use sync presets, also referred to as IR presets, to automatically set transmitter parameters from the receiver during an IR sync.

Select the parameters you'd like to use presets for in the IR presets menu. Each preset has the default value of No Change, which leave that setting unchanged by an IR sync.

1. Select from the channel menu: Sync Presets
2. Use the control wheel to select and edit parameters from the preset list. Select No Change to keep existing settings.
3. Press ENTER to save.

## Manually Set a Frequency

The ANX4 can be manually tuned to a specific group, channel, or frequency.

1. Select a channel and go to Radio.
2. Use the control wheel to set the group (G), channel (C), or frequency.
3. Press ENTER to save changes.
4. Optionally, press Next to move to the next channel.

## Request a New Frequency from a Spectrum Manager

When you have assigned a Spectrum Manager to act as a frequency server for the ANX4, you can quickly move to a clear frequency in the event of interference.

1. From a channel menu, go to **Radio > New Freq . .**

**Note:** *New Freq. only appears in the menu if your device is managed by a Spectrum Manager.*

2. Select **ENTER** to get a new frequency from the Spectrum Manager.
3. The new frequency is automatically shared to any linked, active portable devices. Update the frequencies of any non-ShowLink transmitters using IR sync.

## Registered Transmitters in Transmitter Slots (Axient® Digital Only)

In AD mode, each ANX4 channel contains 8 transmitter slots to control the RF signals passed by the receiver. Transmitters can be assigned to the channel slots, or "registered" with the receiver.

For added protection from interference, the receiver can issue a warning or block signals from any transmitters that aren't registered.

To assign a transmitter to a receiver channel:

1. From a channel menu, go to **Transmitter(s)**.
2. Use the control wheel to scroll to an available transmitter slot. If the slot is occupied, syncing will overwrite the existing transmitter.
3. Align the transmitter with the IR sync window and press **Sync**.

When the sync is complete, the transmitter is assigned to the slot, and remains assigned until it is unlinked. To remove a transmitter from a slot, use the control wheel to select the slot, and then press **Unlink**.

Other transmitter slot options:

- **Activate** (ADX transmitters linked to ShowLink access point only): Press to RF mute all other ShowLink active transmitters
- **Identify** (ADX transmitters linked to ShowLink access point only): Press to flash the display of the linked transmitter

Icons in each transmitter slot indicate the ShowLink status, RF level, and more. See the [Icons](#) topic for information.

## Interference Management

In the event of signal degradation, tools in the Interference Management menu can help you move to a clean, compatible frequency. Turn interference detection on or off for each channel individually.

**Tip:** To dismiss an interference alert, select the affected channel and choose **Dismiss**.

### ULX-D®

For ULX-D® channels, turn interference detection on to monitor the RF environment for potential sources of interference that could cause audio dropouts.

In the event of interference, the RF LEDs illuminate red and a warning appears on the receiver panel. If the warning persists or the audio drops out repeatedly, perform a scan and sync at the first opportunity to find a clear frequency.

To turn interference detection on or off, select a channel and choose **Interference Management**. Settings:

- **Off:** Do not detect interference
- **On:** Detect interference and select a frequency manually when interference occurs

## Spectrum Manager

For ULX-D® channels, assign a networked Spectrum Manager as a server to find and assign clear frequencies in the event of interference.

1. From the Interference Management menu, select Spectrum Manager.
2. Press the control wheel to enable editing, and then select a Spectrum Manager from your network.
3. Press ENTER to save.

## Axient® Digital

For Axient® Digital channels, the interference detection setting determines how the ANX4 will switch to a clear frequency in the event of interference.

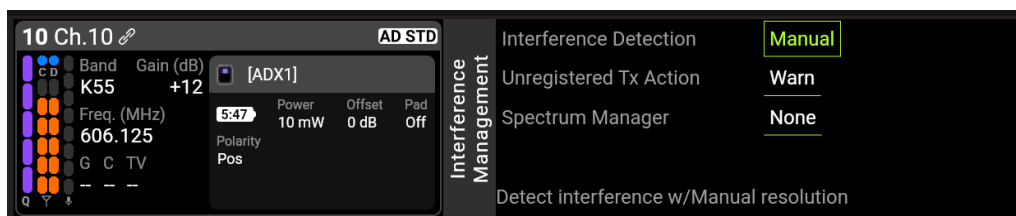

**Interference management for Axient Digital channel**

To turn interference detection on or off, open the channel menu and go to Interference Management. Settings:

- Manual: Select a frequency manually when interference occurs
- Automatic: Allow the receiver to automatically select a new frequency
- Off: Do not detect interference

## Unregistered Tx Action

The unregistered transmitter setting determines how the receiver reacts to the presence of unregistered transmitters, which can be a potential source of interference.

From the Interference Management menu, choose one of the following options:

- Warn: Display a warning when an unregistered transmitter is detected
- Block: Treat unregistered transmitters as interference and block the audio
- Allow: Pass audio from unregistered transmitters

## Spectrum Manager

For Axient® Digital channels, assign a networked Spectrum Manager as a server to find and assign clear frequencies in the event of interference.

1. From the Interference Management menu, select Spectrum Manager.
2. Press the control wheel to enable editing, and then select a Spectrum Manager from your network.
3. Press ENTER to save.

## Frequency Diversity

Frequency diversity safeguards against loss of audio signal caused by RF interference or power loss in a transmitter.

Using frequency diversity in conjunction with Interference Detection provides an additional layer of protection for the audio signal.

**Note:** Frequency diversity is currently only available for Axient® Digital devices on the ANX4.

## Axient® Digital

In frequency diversity mode for Axient® Digital devices, the ANX4 uses 2 frequencies to provide a single channel of audio. If one frequency experiences interference, the audio from the other frequency is used to prevent dropouts or interruption of the audio.

**Note:** Configure frequency diversity from odd-numbered channels.

In **Selection mode (FD-S)**, the ANX4 receives audio from 2 AD/ADX series transmitters.

In **Combining mode (FD-C)**, the ANX4 receives audio on 2 frequencies from 2 channels via a single ADX2FD handheld transmitter.

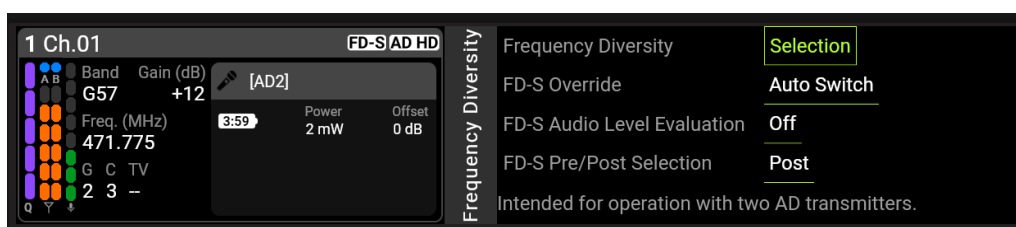

**Selection mode (FD-S)**

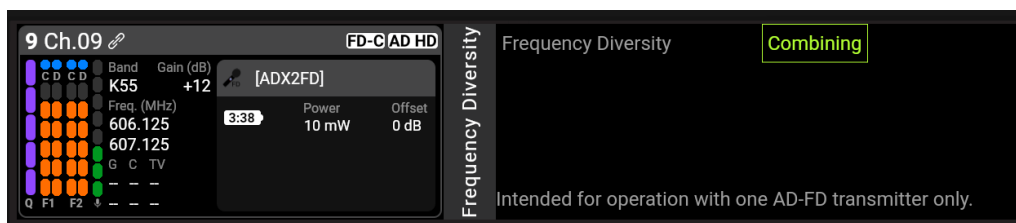

**Combining mode (FD-C)**

1. Because frequency diversity uses 2 channels, it is configured from odd-numbered channels. From a channel menu, go to Frequency Diversity.
2. Choose one of the following frequency diversity modes:
  - Selection (FD-S): For use with a pair of AD1 or ADX1 series transmitters
  - Combining (FD-C): For use with a single ADX2FD handheld transmitter
3. If using FD-S, configure the following settings:
  - FD-S Override: Choose which signal takes precedence.  
Auto Switch: Automatically moves between the two signals.
  - Lock to RxA: Signal from channel A overrides signal from channel B. This is a temporary setting and will revert to Auto Switch after a device restart or when Frequency Diversity mode is exited and re-entered.
  - FD-S Audio Level Evaluation
  - FD-S Pre/Post Selection
4. Press ENTER to save.
5. Perform an IR sync between the receiver and the transmitter(s).

## Antenna Bias

All antenna ports provide a DC bias to power active antennas. Set the DC power to off when using passive (non-powered) antennas.

In the Device Configuration menu, go to Device RF > Antenna Bias to turn DC power on or off. The antenna bias screen also shows the current draw for each antenna and the total current draw for all antennas combined and indicates whether an antenna fault is occurring.

## Quadversity™ (Axient® Digital only)

Quadversity™, available only when the ANX4 is in Axient Digital mode (standard or HD), combines the signal from 4 antennas to maximize RF coverage and minimize the risk of dropouts and signal loss caused by interference.

To use Quadversity™ on the ANX4, set the antenna pairs to cover the same RF band, then select Quadversity™ from an individual channel menu.

**Note:** On the ANX4, you can apply Quadversity™ mode to a channel without rebooting.

1. From the Device Configuration menu, go to Device RF > Antenna Configuration.
2. Set antennas AB and CD to the same RF band. Where the tuning ranges of your antennas overlap, you're able to use Quadversity™. On the visual spectrum, this range is highlighted with the note "Quadversity Capable".

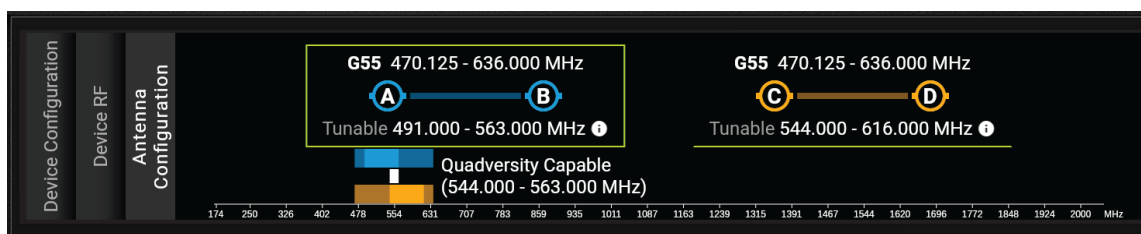

3. Because Quadversity™ takes up 2 channels, select an odd-numbered™ channel. From the Channel menu, go to RF Band > Antenna and choose Quadversity. This option only appears when:
  - ANX4 is set to an Axient Digital transmission mode
  - Both antenna pairs are set to the same RF band
  - Antenna pairs have overlapping tuning range
  - Channel is odd-numbered
4. Press ENTER to save the change.

**Channel usage in Quadversity™ mode:** Quadversity™ takes up 2 channels. If Channel 1 is a Quadversity™ channel, your channel list will show Channel 1 and then skip to Channel 3.

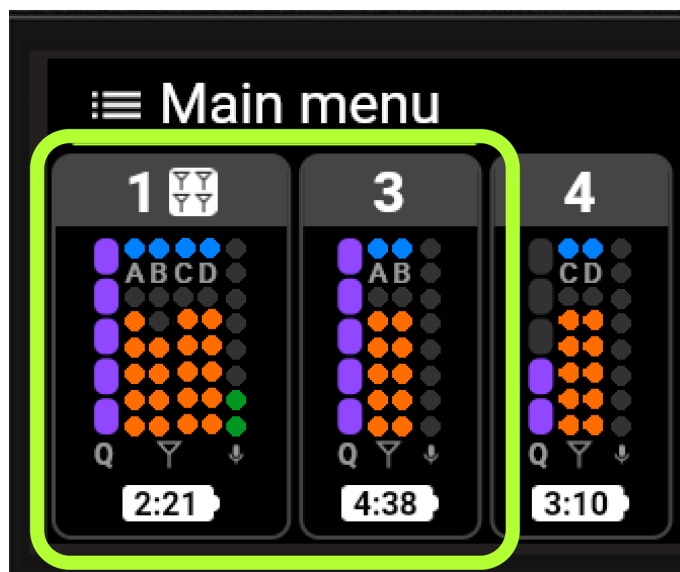

Detailed view of channel in Quadversity™ mode:

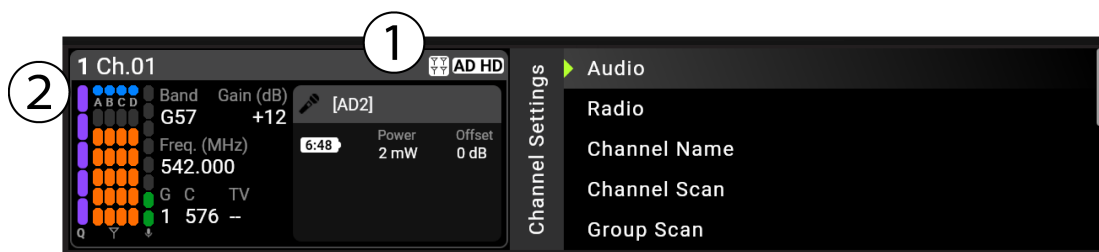

1. Icon indicating channel is using Quadversity™
2. Antennas A, B, C, and D all covering this channel

## Audio Settings

### Adjust Channel Gain

During setup or performance, adjust the gain in real time for each channel.

1. Select a channel and go to the Audio menu.
2. Use the control wheel to select and edit the gain from -18 dB to +42 dB.

**Tip:** Adjust the gain while performing a sound check using typical audio input signal levels and monitor the audio meter LEDs. Reduce the gain if the red LED keeps flashing.

### Update Audio Output

Mute and unmute a channel in real time by adjusting the audio output.

1. Select a channel and go to Audio.
2. Set the output to On or Mute. This is a live edit, so you'll hear the change right away.

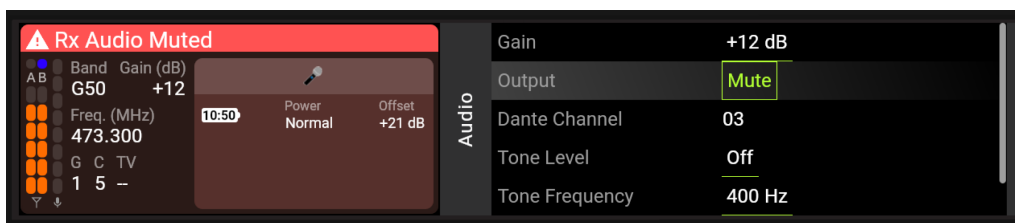

A channel with the audio muted

## Tone Generator

The ANX4 has a built-in tone generator, which is a continuous audio signal useful for sound checks and system troubleshooting. Adjust the level and frequency of the tone in the channel menu.

**Note:** The tone generator enters the signal chain before the system gain. The overall system gain will affect the level of the tone.

1. Select a channel and go to Audio.
2. Use the control wheel to select a level and frequency for the tone.
3. To stop the tone, set the tone level to Off.



A channel with the tone generator on

## Headphone Monitoring

The ANX4 has a 1/4" headphone jack for monitoring audio signals.

To monitor a channel with headphones:

1. Press the headphone knob or select Headphone Monitor from the main menu.
2. Use the control wheel to select a channel.
3. Use the headphone knob to control the volume of the headphones.
4. Adjust the limiter threshold to protect against unexpected increases in signal level.

## Dante Browse

Use Dante browse to listen to audio from the Dante-enabled devices on your network.

1. Go to Device Configuration > Device Audio > Dante Browse.
2. Choose Shure to display only Shure devices or All to display any Dante-enabled device.
3. At any time, press Refresh to see if devices have joined or left the network.
4. Use the control wheel to select a device and channel from the network list.
5. Use the headphone knob to adjust the volume.

## Dante Device Lock

Dante Device Lock is a feature of Dante Controller that allows you to lock and unlock supported Dante devices using a 4-digit PIN (Personal Identification Number). When a device has a Dante lock turned on, Dante audio will continue to flow according to existing subscriptions, but its subscriptions and settings can't be controlled or configured.

Go to [Device Configuration > Device Audio > Dante Device Lock](#) to see the status of Dante Device Lock for the ANX4.

Refer to the [Dante Controller documentation](#) for instructions on how to unlock a device.

## Dante Domain Manager

This device is compatible with Dante Domain Manager software (DDM). DDM is network management software with user authentication, role based security, and auditing features for Dante networks and Dante-enabled products.

Go to [Device Configuration > Device Audio > Dante Domain Manager](#) to see domain status for Dante devices on your network.

Considerations for Shure devices controlled by Dante Domain Manager:

- When you add Shure devices to a Dante domain, set the local controller access to Read Write. Otherwise, you won't be able to access Dante settings, perform a factory reset, or update device firmware.
- If the device and DDM can't communicate over the network for any reason, you won't be able to control Dante settings, perform a factory reset, or update device firmware. When the connection is reestablished, the device follows the policy set for it in the Dante domain.
- If Dante device lock is on, DDM is offline, or the configuration of the device is set to Prevent, some device settings are disabled. These include: Dante encryption, MXW association, AD4 Dante browse and Dante cue, and SCM820 linking.

Refer to [Dante Domain Manager's documentation](#) for more information.

---

## Operation

### Assign a Device ID

Assign the ANX4 a device ID to keep your system organized and help identify your device in ShureCloud and Shure control applications.

1. Go to [Device Configuration > Device ID](#).
2. Use the control wheel to name the ANX4.
3. Press ENTER to save.

### Assign a Channel Name

Assign unique names to each channel to help identify and organize channels within a large system.

1. Select a channel and go to Channel Name.
2. Use the control wheel to assign a channel name.
3. Press ENTER to save.
4. Optionally, press Next to move to the next channel.
5. Press EXIT when you are done editing channel names.

### Update Number of Displayed Channels

The ANX4 home display scales to the number of licenses available and active on the receiver. Set the displayed channel count to update the number of channels that appear on the home screen.

Updating the displayed channel count also dictates how many channels you see in control applications.

## How to Update Displayed Channel Count

- Go to Device Configuration > Channel Count. In the channel count menu, you see:
  - Total channels available (24 in ULX-D modes and 16 in Axient Digital modes)
  - Number of channels licensed
  - Displayed channel count
- Press ENTER and use the control wheel to select a channel count.
- Press ENTER to save changes. The ANX4 restarts to reflect the updated displayed channel count.

## Why Change the Displayed Channel Count?

Examples of when you might want to see fewer or more channels than you have licensed on the home display:

- Fewer channels: You have 24 channels available for an event that only needs 16 channels. Set the displayed channel count to 16 to see more information about each channel and remove clutter from the home display.
- More channels: You currently have 8 channels licensed but are preparing for an event where you'll be using 12 channels. Set the displayed channel count to 12 channels to preview, coordinate, and name those channels on the ANX4 or in control software prior to the licenses being active.

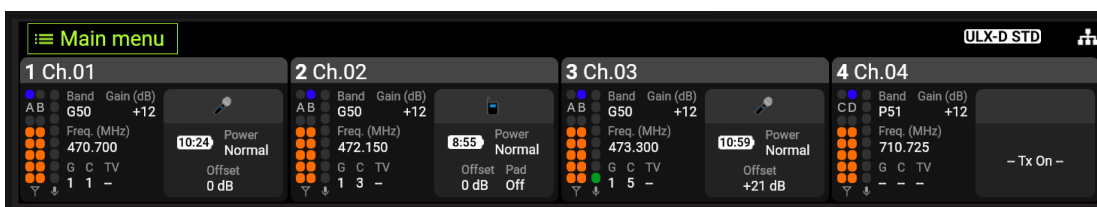

4 channels on display (ULX-D standard mode)

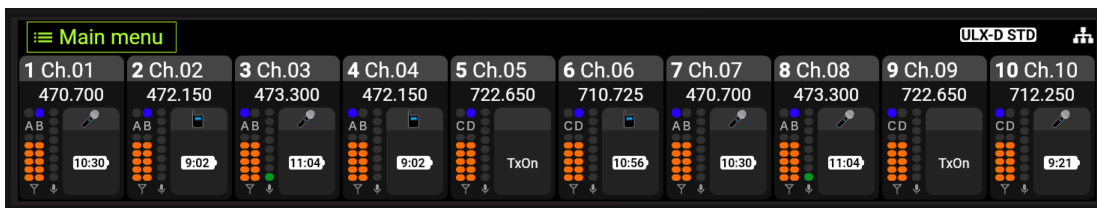

10 channels on display (ULX-D standard mode)

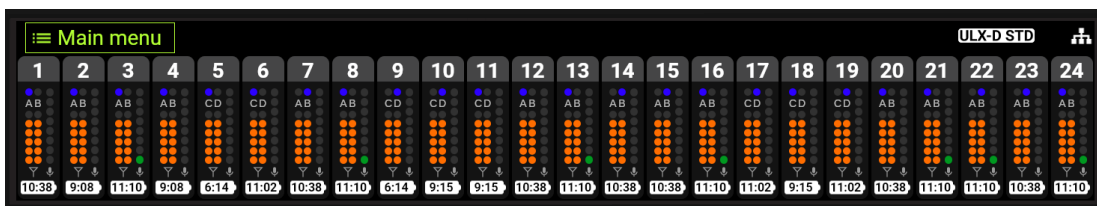

24 channels on display (ULX-D standard mode)

## Device Locks and Access Control

Lock the front panel controls or power button to prevent accidental or unauthorized changes via the ANX4 hardware.

1. From the Device Configuration menu, go to Locks.
2. Use the control wheel to change the lock status for the power switch or front panel controls.
3. Press ENTER to save.

### Access Control

Access control allows for the assignment of PINs to protect against unauthorized access to networked components from a computer running Wireless Workbench or other Shure software. When access control is enabled, you can only modify device settings after entering a PIN.

To turn access control off, go to Device Configuration > Locks and enter the device's PIN.

Access control is enabled via Wireless Workbench or another Shure control application. Go to [Wireless Workbench - Access Control](#) for the steps to enable access control.

## License Status and Limits

On the ANX4, go to Device Configuration > License Status to find information related to licenses and add a license limit code.

### License Limits

To prevent unauthorized changes to the number of channel licenses an ANX4 can use, add a license limit code and set a license limit.

License limits can be adjusted without connection to the internet. Setting a license limit doesn't return the unused channel licenses to the pool of licenses available to use. To re-use channel licenses on another ANX4, manage the number of active licenses in ShureCloud. Refer to [Manage Licenses](#) for instructions.

1. Go to Device Configuration > License Status and select Code.
2. Use the control wheel to select a license limit.
3. Set a code. The code must be 6 numbers, letters, or a combination.
4. If the license limit is different from the current number of licenses, the device reboots to update the license count.

Until the limit is updated or license activation is modified in ShureCloud, the device treats the license limit as the available number of channel licenses.

Factory reset doesn't affect the license limit or license limit code. To remove a license limit code:

- If you know your code, go to Device Configuration > License Status, enter your code, and choose to clear the code. This clears the code and reverts the license limit to the number of licenses activated.
- If you forget your code, update license activation in ShureCloud.

## Factory Reset

A factory reset restores all parameters to factory settings.

**Note:** Performing a factory reset on the ANX4 does not affect the number of channel licenses on the device. For information about how to move or deactivate licenses, refer to [Manage Licenses](#).

To factory reset the ANX4:

1. Go to Device Configuration > Factory Reset
2. Select ENTER.
3. The ANX4 reboots to apply factory settings.

# Device Redundancy

For critical applications, designate a backup ANX4 using device redundancy. Device redundancy enables you to set up a backup ANX4 to mirror your primary device. The backup, or redundant, ANX4 duplicates the key settings of the primary ANX4 so you have a hot spare ready to go in case of emergency.

Once a device is designated as redundant, most changes to settings of the primary device, either on the device itself or in Wireless Workbench, are applied to the redundant device. Duplicated settings include:

- Transmission mode
- Antenna configuration
- RF settings, except designated Spectrum Manger
- Group, channel, and frequency
- Channel audio settings
- Dante channel labels
- For Axient Digital, transmitter registration
- Encryption
- Interference management

## Designate a Redundant ANX4

Connect a second ANX4 to your network to designate it as a backup, or redundant, device. The redundant device replicates key settings of the primary device, and most changes made on the primary are mirrored on the redundant device. Once a device is marked as redundant, avoid making changes to audio and RF settings.

Enable device redundancy from the Device Configuration menu of the redundant receiver or in Wireless Workbench.

### On the hardware:







1. On the redundant ANX4, go to **Device Configuration > Device Redundancy**.
2. Select a primary ANX4 to replicate. Highlight a device and press **Identify** to flash the front panel.
3. Press **ENTER** to confirm. The device reboots, potentially more than once, to apply the settings of the primary receiver.
4. Optionally, to prevent accidental changes to the redundant device:
  - Assign meaningful device IDs, like [Studio A ANX4-Primary] and [Studio A ANX4-Redundant]
  - Lock the front panel
  - Use color or tags to differentiate the redundant device in Wireless Workbench
  - Turn on access control. Refer to [Wireless Workbench - Access Control](#) for instructions.

### In Wireless Workbench:

1. Open the properties panel for the redundant ANX4.
2. Click the gear icon to open general settings.
3. Scroll **Device Redundancy** and turn on redundancy.
4. Select a primary device to replicate. The device reboots, potentially more than once, to apply the settings of the primary receiver.
5. Optionally, to prevent accidental changes to the redundant device:
  - Assign meaningful device IDs, like ANX4-Primary and ANX4-Redundant
  - Lock the front panel
  - Use color or tags to differentiate the redundant device in Wireless Workbench
  - Turn on access control. Refer to [Wireless Workbench - Access Control](#) for instructions.

## Device Redundancy Statuses

Device	Redundancy Status	Status Icon	Description
Primary	Online		Connected to redundant device

Device	Redundancy Status	Status Icon	Description
	<b>Offline</b>		Primary device can't reach redundant device
	<b>Error</b>		See the device alert message for details
<b>Redundant</b>	Online In Sync		Ready to replace primary device
	<b>Online Syncing</b>		Replicating settings of primary device
	<b>Offline</b>		Redundant device can't reach primary device
	<b>Error</b>		See the device alert message for details

## Switch to a Redundant Device

In the event that the primary device has failed or is no longer available, switch to your redundant ANX4.

1. Turn off device redundancy on the redundant device so it can function as a normal receiver.
  - On hardware: Device Configuration > Device Redundancy
  - In Wireless Workbench: Properties panel for redundant device, click the gear icon, scroll to Device Redundancy
2. Re-create Dante routes and/or confirm the audio routes are connected to the redundant device.
3. If using a Spectrum Manager, unselect the primary device and select the redundant device.
4. If using ADX-series portables (ShowLink), IR sync those portables to the redundant device.

## Manage Licenses

To make any changes to channel license activation, ensure cloud connectivity is enabled (Device Configuration > Network Services) and connect your device to the internet. Once you are done configuring licenses, the device doesn't need to stay connected to the internet and you can turn off cloud connectivity.

## Update License Count

Add or remove individual channel licenses from your devices in ShureCloud. Reducing the number of channels activated on a particular device returns those channels to your pool of remaining licenses, which you can then assign to another device.

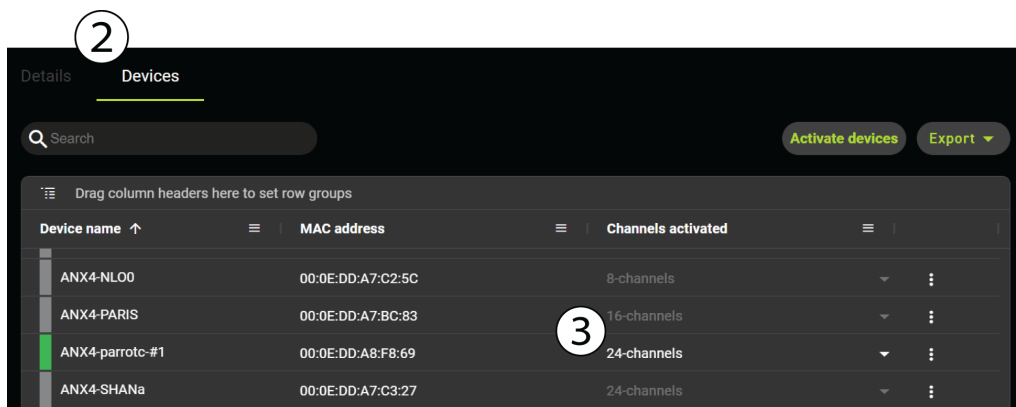

1. Go to ShureCloud > Licenses and double-click the appropriate license group.
2. Open the Devices tab.
3. Select a device and adjust the number of activated channels in the Channels activated column. As you add or remove licenses, the number of remaining channel expansion licenses updates to show how many licenses you have left to assign.
4. Click Change License to confirm your selection. The device reboots to apply the updated license count.

## Move Licenses Between Your Own Devices

To move licenses between devices, update the license count for an existing device (In your [ShureCloud account](#): Licenses > Devices). Licenses not in use are returned to your pool of available licenses and can then be assigned to a different device, either via the Channels activated column for devices that have already been activated, or via the Activate devices button.

## Move Licenses Between License Groups

1. Go to ShureCloud > Licenses and open a license group.
2. Select Move licenses.
3. Indicate how many licenses you'd like to move and choose to move them to an existing license group or create a new license group.
4. Click Move licenses.

## Deactivate a Device

Deactivating a device removes the licenses from that device so they can be used elsewhere. If you want to remove only some of the licenses rather than deactivate the whole device, [update the license count](#).

To deactivate a device:

1. Go to ShureCloud > Licenses > Devices.
2. Click the three dots next to the device you'd like to deactivate.
3. Click Deactivate.

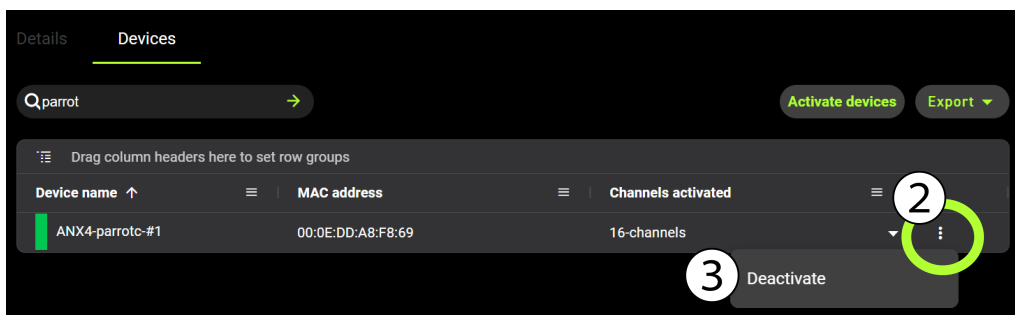

## Transfer Channel Licenses

Transfer channel licenses to other organizations in ShureCloud. Channel licenses are device-specific and can only be used on devices of the same type. For example, ANX4 channel licenses can only be activated on other ANX4 devices.

To manage, transfer, and accept channel licenses, users must be a license or organization admin in ShureCloud. View member roles in an organization in the Users tab. For more information on user roles and permissions, see [Manage User Accounts](#) in the ShureCloud user guide.

## Transfer Channel Licenses to Another Organization

Prepare channel licenses to be transferred to another organization in ShureCloud.

1. In ShureCloud, go to Licenses and select the device type in the left column.
2. Select Transfer licenses.
3. Select the license group you want to transfer channel licenses out of from the dropdown, and set how many channel licenses you are transferring.

**Note:** Channel licenses that are currently activated on a device can not be transferred. Check how many available channel licenses a license group has by double-clicking the group in the table.

4. The selected channel licenses are placed in a new license group. Name the group and enter contact information, if available, for the organization admin that is receiving the channel licenses.
5. Review the channel license transfer information and select Transfer licenses.
6. Find the new channel license group in the license group table. Take note of the License ID code. The receiving organization will use the License ID code to accept the transferred channel licenses.

## Receive Channel Licenses in Your Organization

Claim channel licenses from the receiving organization in ShureCloud. Refer to Add Channel Licenses via Claim Code for instructions.

## Add Channel Licenses via Claim Code

Add channel licenses you receive via claim code to your ShureCloud account in the Licenses tab.

Steps are different depending on whether your organization has registered licenses or not.

**First time adding licenses:**

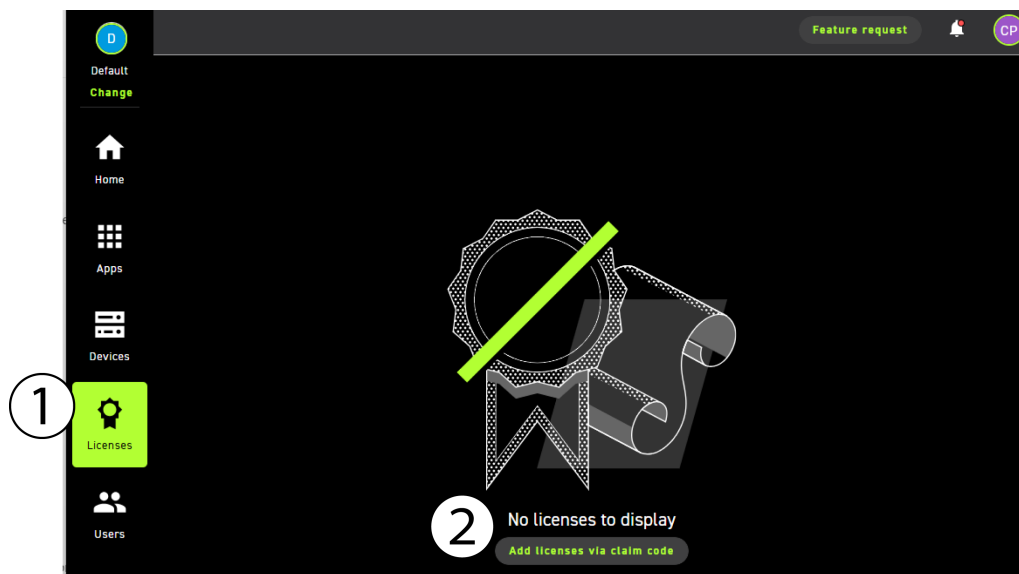

1. In ShureCloud, go to Licenses.
2. Click Add licenses via claim code.

**Note:** Channel licenses can only be used on the device types for which they were purchased (channel licenses for ANX4 devices cannot be used for Axient® Digital PSM® devices, etc.)

3. Fill in your organization's information in the form that appears.

**Important!:** Complete the form when you access it. If you navigate away from the form, you won't be able to return to it.

4. Once the form is submitted, you are redirected to ShureCloud. Click Add licenses via claim code and enter your code.
5. Verify that the Organization owning licenses listed is correct and enter the claim code.
6. Double-click your license group.

**Note:** License groups are collections of licenses purchased at the same time.

7. In the Details pane, view the remaining, activated, and total licenses for this license group. Click Activate Devices and select your device.
8. In the dropdown menu, choose the number of channels to add to the device.
9. Click **Next** and follow the prompts to activate your channel licenses.
10. The device reboots to apply the licenses. The reboot takes between 45 seconds and one minute.

**If there are existing licenses:**

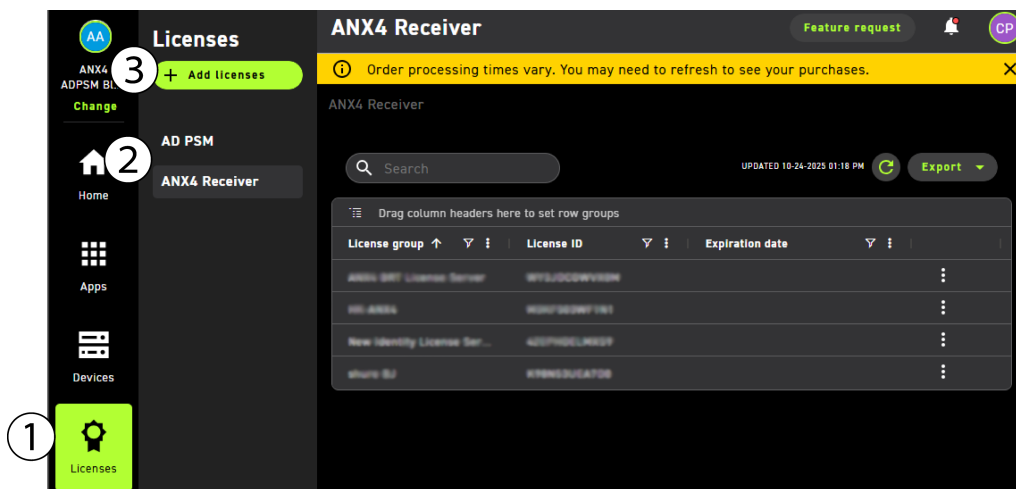

1. In ShureCloud, go to Licenses.
2. Select the device type.

**Note:** Channel licenses can only be used on the device types for which they were purchased (channel licenses for ANX4 devices cannot be used for Axient® Digital PSM® devices, etc.)

3. Click **Add Licenses**.
4. Verify that the Organization owning licenses listed is correct and enter the claim code.
5. Double-click your license group.

**Note:** License groups are collections of licenses purchased at the same time.

6. In the Details pane, view the remaining, activated, and total licenses for this license group. Click Activate Devices and select your device.
7. In the drop down menu, choose the number of channels to add to the device.
8. Click **Next** and follow the prompts to activate your channel licenses.
9. The device reboots to apply the licenses. The reboot takes between 45 seconds and one minute.

## Firmware Updates

Firmware is embedded software in each component that controls functionality. Installing the latest version of firmware updates the receiver to incorporate additional features and enhancements. Upload and install new firmware versions using the [Shure Update Utility](#) tool or in [ShureCloud](#).

The transmission mode does not affect the firmware update process for the ANX4.

## Firmware Versions

When you update receiver firmware, update your transmitters to the same firmware version to ensure consistent operation.

The firmware of all devices has the form of MAJOR.MINOR.PATCH (e.g., 1.2.14). At a minimum, all devices on the network (including transmitters), must have the same MAJOR and MINOR firmware version numbers (e.g., 1.2.x).

## Update Firmware in ShureCloud

Use ShureCloud to update firmware for supported hardware devices, including ANX4. Go to [cloud.shure.com](https://cloud.shure.com) and open the Device management app to see and update device firmware.

In the device list:

- Sort the devices in your list by firmware status or model to easily manage firmware.
- Select a group of devices to update them all at the same time.

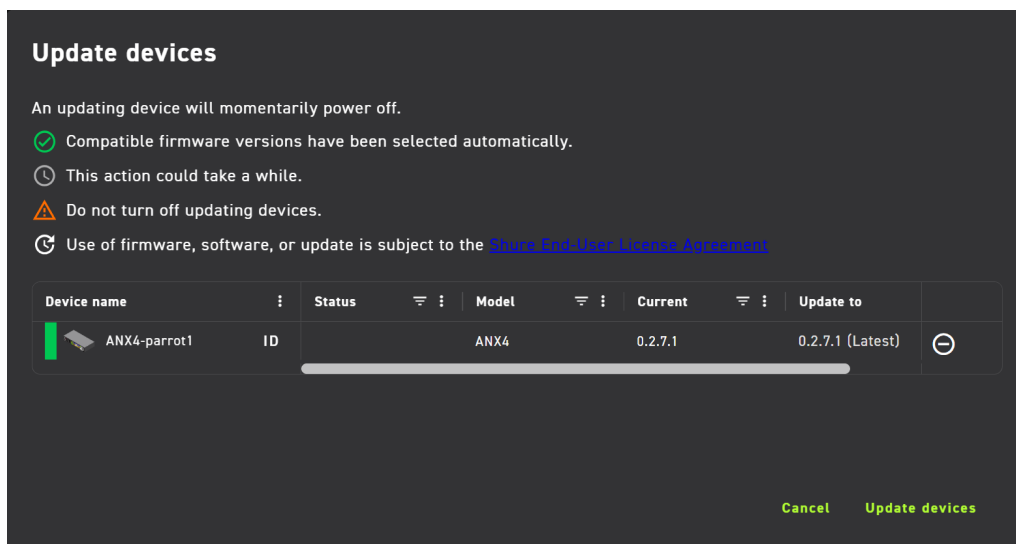

**To update devices:**

1. In ShureCloud, open Device management. Sort the devices as needed using the columns.
2. Use the checkboxes to select a device or group of devices to update.
3. Click Update selected and follow the instructions.

## Update Firmware in Shure Update Utility

**CAUTION!** Ensure that receiver power and network connections are maintained during a firmware update. Do not turn off the receiver until the update is complete.

1. Open the Shure Update Utility.
2. Click Check Now or [#] updates available to view new versions available for download.
3. Select the updates and click Download.
4. Connect the receiver and computer to the same network.
5. Select a firmware version from the Version to install dropdown menu. In the transmitter row, this dropdown contains both AD and ULX-D firmware versions.
6. Click Send [#] updates to download the latest firmware to the receiver.

For more detailed network setup instructions and information about firmware, refer to the [Shure Update Utility user guide](#).

## Update the Transmitter Firmware

1. From the Device Configuration menu of the receiver: Tx Firmware Update.

*The hosted firmware listed (AD or ULX-D) is the most recent transmitter firmware added to the receiver and must match the type of transmitter being updated. If the hosted firmware is ADTx and the transmitter you're updating is ULX-D, go to Shure Update Utility or ShureCloud to download transmitter firmware.*

2. Turn on the transmitter and align the IR sync windows on the transmitter and receiver. The red alignment LED will illuminate when alignment is correct.
3. Maintain alignment and press ENTER on the receiver to begin the update.

Alignment must be maintained during the entire update cycle. Percentage of update progress appears on the receiver display. The receiver display will show the message Complete! when finished.

---

## ANX4 DC Power Module

The DC power module allows ANX4 operate on AC or DC power. The DC module provides power if AC power fails or is unavailable. Switching between AC and DC occurs seamlessly, without affecting operation.

Features:

- Operation from a DC power source
- Overvoltage and Undervoltage protection
- Reverse-polarity protection

## Power Connections

The DC module can operate in the following input modes:

- AC and DC
- AC only
- DC only

1. Make sure the ANX4 power switch is set to off.
2. Connect an AC power source to the AC input.
3. Connect a DC power source to the DC input.
4. Set the ANX4 power switch to on.

**Note:** The ANX4 operates using AC power unless the AC power source fails or is disconnected.

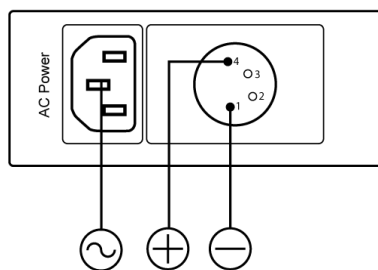

## Monitoring the DC Power Status

See the status of the DC module in the Device Configuration menu.

1. From the Device Configuration menu choose DC Module Status.
2. The DC Module screen displays the following information:
  - POWER SOURCE: AC or DC
  - DC MODULE INSTALLED: Yes or No
  - DC POWER AVAILABLE: Yes or No

Main	Device Configuration	DC Module Status	Power Source	DC
			DC Module Installed	Yes
			DC Power Available	Yes

## Connector Wiring Diagram DC to 4-Pin XLR

Recommended cable gauge for connector:

- 3.5 feet or less: 18 AWG (1 mm<sup>2</sup>)
- 4 to 6 feet: 16 AWG (1.5 mm<sup>2</sup>)
- 7 to 10 feet: 14 AWG (2.5 mm<sup>2</sup>)

**Note:** The shell of the DC inlet XLR connector is connected to Chassis Ground.

**Important:** Total cable length should not exceed 10 feet.

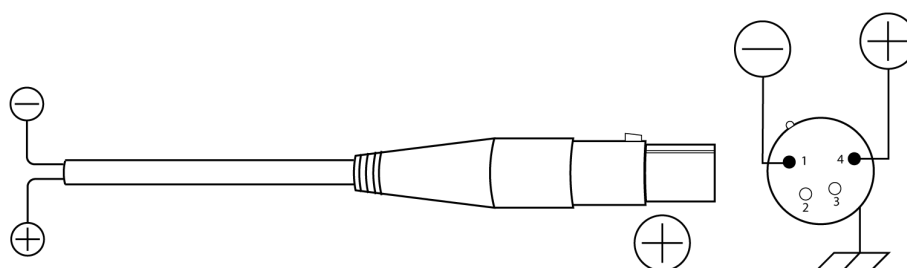

## Networking

The ANX4 has 4 network ports for control and Dante digital audio signals. Dante technology provides an integrated solution to monitor digital audio. Dante uses standard IP over Ethernet and safely coexists on the same network as IT and control data. Selectable networking modes route port signals for flexible network setup.

### Network Signal Types

The following signal types are supported on the network:

- Shure control: Shure Wireless Workbench software provides comprehensive control for wireless audio systems
- Dante primary: Dante digital audio signals
- Dante secondary: Second copy (redundant) of the Dante primary audio

Tip: See the [Dante Controller user guide](#) for more information on Dante redundancy.

## Guided Network Configuration

The ANX4 offers guided setup to simplify networking of your gear.

Network setup includes the following:

- Selecting a switch configuration, or network mode (split/redundant or switched)
- Setting the interface mode for Shure control, Dante primary, and Dante secondary, if applicable

## Step 1: Select a Switch Mode

The switch mode determines what type of network signals are routed to each port.

1. From the main menu: Device Configuration > Network Configuration > Setup.
2. Use the control wheel to set the switch mode to Switched or Split/Redundant.
  - Switched: The receiver acts as a 4-port network switch, routing Shure control and Dante primary audio to all 4 network ports.
  - Split/Redundant: Shure control, Dante primary and Dante secondary are on separate networks. You're still able to take advantage of Dante redundancy.

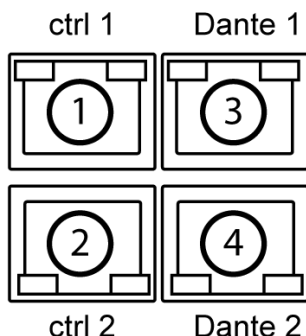

### Switched Mode Port Signals

- ① Shure control and Dante primary
- ② Shure control and Dante primary
- ③ Shure control and Dante primary
- ④ Shure control and Dante primary

### Split/Redundant Mode Port Signals

- ① Shure control
- ② Shure control
- ③ Dante primary
- ④ Dante secondary

3. Press Next.

## Step 2: Set the Interface Mode (IP Address)

Each device requires an IP address for communication and control and a separate Dante IP address. You can assign IP addresses automatically using a DHCP server or manually from a list of valid IP addresses.

Press **Next** and Back to navigate between signal types.

### Shure Control

Choose between Automatic and Manual IP addressing and DNS (Domain Name System) configuration. If you select Manual, use the control wheel to set applicable values.

### Dante Primary

Choose between Automatic and Manual IP addressing. If you select Manual, use the control wheel to set an IP address.

### Dante Secondary

Only appears if ANX4 is in Split/Redundant mode. Choose between Automatic and Manual IP addressing.

Press ENTER to apply settings.

## Network Services

Turn network services, such as cloud connectivity, on or off in the Network Services menu.

Go to Main menu > Device Configuration > Network Services to see and update cloud connectivity status for the device.

- Cloud connectivity on: This ANX4 can be discovered by ShureCloud. Cloud connectivity must be enabled to install licenses.
- Cloud connectivity off: This ANX4 cannot be discovered by cloud applications, and the device won't try to contact the internet.

## Access the Network with a Computer

You can control and monitor all networked receivers through a computer running Shure Wireless Workbench<sup>®</sup> software. If using the default automatic network setting, make sure your computer is configured for DHCP. For more detailed networking instructions for Wireless Workbench, see the [Wireless Workbench - Networking help topic](#).

## Connecting Receivers

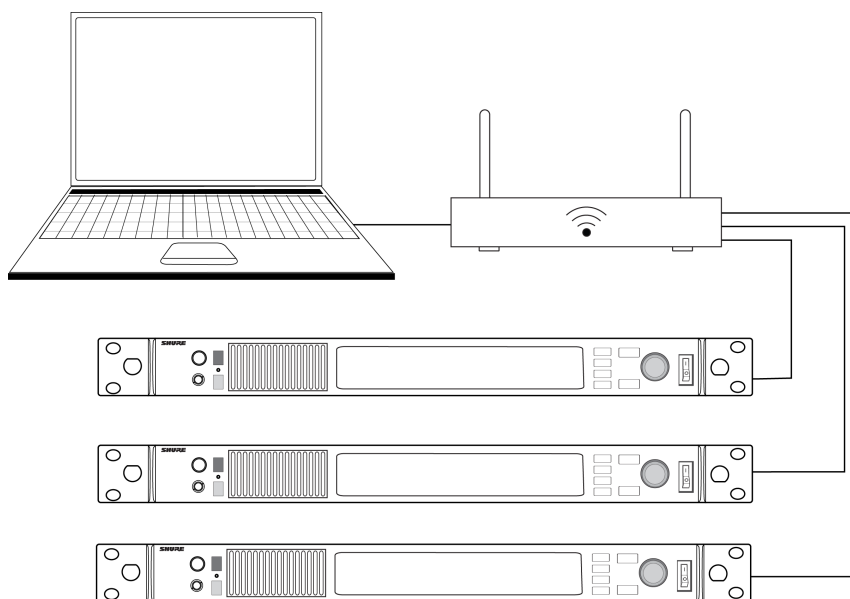

Router with DHCP

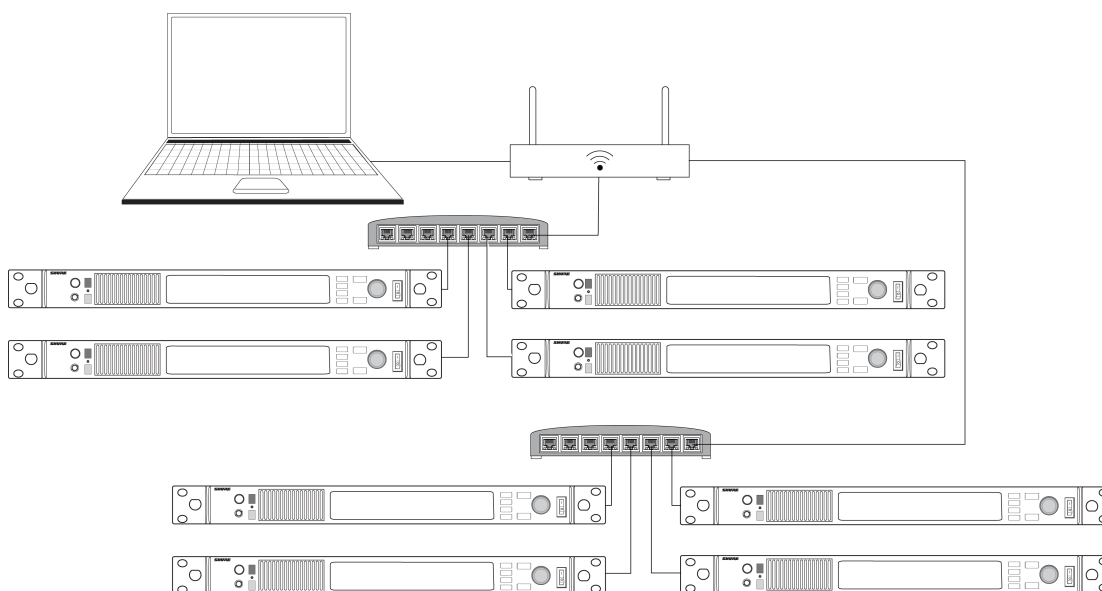

**Extended network**

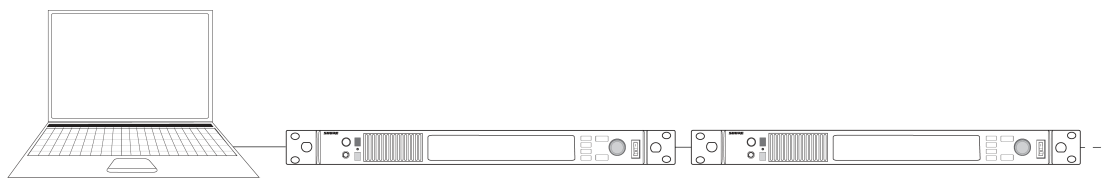

**Direct connection to computer**

## Network Troubleshooting

- Use only one DHCP server per network
- All devices must share the same subnet mask. Refer to the [IP Addresses and Subnet Masks FAQ](#) for background and examples
- All receivers must have the same level of firmware revision installed
- Look for the illuminated network icon on the front panel or display of each device:
  - If the icon is not illuminated, check the cable connection and the LEDs on the network jack
  - If the LEDs are not on and the cable is plugged in, replace the cable and recheck the LEDs and network icon
- Refer to the [Wireless Workbench Network Troubleshooting](#) page for information on how to troubleshoot Wireless Workbench's connection to the network

# Troubleshooting

Issue	Solution
<b>No sound</b>	<p>Confirm that your device has the appropriate number of channel licenses (Device Configuration &gt; License Status). Refer to <a href="#">License Setup</a> for further guidance.</p> <p>Make sure the receiver and transmitter are receiving sufficient voltage:</p> <p>Check the battery indicators and replace transmitter batteries if necessary. Check that all cables and connectors are working correctly.</p> <p>Enable or disable encryption and re-sync all receivers and transmitters.</p> <p>See the Radio Frequency topic below for further troubleshooting steps.</p>
<b>Faint sound or distortion</b>	<p>Check that all cables and connectors are working correctly.</p> <p>Adjust the system gain on the front of the receiver. Ensure the output level on the back of the receiver corresponds to the mic/line input setting of the mixing console, amplifier, or DSP.</p>
<b>Lack of range, unwanted noise bursts, or dropouts</b>	<p>See Radio Frequency troubleshooting steps below.</p>
<b>Cannot turn transmitter off or change frequency settings, or can't program receiver</b>	<p>The transmitter and the receiver can be locked to prevent accidental or unauthorized changes. For steps to unlock receiver settings (front panel, power, controls) refer to <a href="#">Device Locks and Access Control</a>. For transmitter locks, refer to the user guide for the locked transmitter.</p>
<b>Encryption mismatch message</b>	<p>Enable or disable encryption and re-sync all receivers and transmitters.</p>
<b>Firmware mismatch message</b>	<p>Paired transmitters and receivers must have the same firmware version installed to ensure consistent operation. Refer to <a href="#">Firmware Updates</a> for steps to update.</p>
<b>Transmitter battery hot message</b>	<p>If the transmitter battery does not cool off, the transmitter will shut down. Let the device cool down and then consider swapping the transmitter battery to continue operation.</p> <p>Identify any possible external heat sources to the transmitter and operate the transmitter away from those external heat sources.</p> <p>All batteries should be stored and operated away from external heat sources in reasonable temperature conditions for best performance.</p>

Issue	Solution
<b>Red antenna LED - antenna fault</b>	<p>The red antenna fault LED indicates a short circuit condition or excessive load at an antenna port.</p> <p>Check antennas and cables for damage            Ensure that antenna ports are not overloaded            Check antenna bias voltage setting. Turn off voltage if using passive antennas.</p>
<b>Handheld transmitter shuts down during use</b>	Clean the battery contacts with an electrical contact cleaner designed for gold contacts and safe on plastics.
<b>Transmitter unavailable message in Transmitter Adjust menu (Axient® Digital only)</b>	Make sure a ShowLink capable transmitter is turned on, in range, and linked to a ShowLink access point

## Radio Frequency (RF) Troubleshooting Steps

### Band compatibility

- Check the band label on the transmitter to make sure it's the same band as the receiver.
- Are the transmitter and receiver set to the same group and channel? Perform a scan and sync to make sure they are. Refer to [Find and Assign Frequencies to your Devices](#) for instructions.

### RF LEDs

- If neither blue RF Diversity LED is illuminated, then the receiver is not detecting the presence of a transmitter.
- The orange RF Signal Strength LEDs indicate the amount of RF power being received. This signal could be from the transmitter, **or it could be from an interfering source, such as a television broadcast**. If more than two of the orange RF LEDs are still illuminated while the transmitter is off, then that channel may be experiencing interference, and you should try a different channel.
- The red RF LED indicates RF overload. Overloads have the potential to cause interference in multiple system installations. If you are experiencing an overload, turn off the receiver to see if it is causing interference with other components.

Note: The numerical channel select button also turns red to indicate interference.

- Dim red = Channel is not selected, experiencing interference
- Bright red = Channel is selected, experiencing interference

### Red RF LED on receiver - RF overload

If you see the red RF LED on a receiver, try the following:

- Reduce the transmitter RF power level
- Move the transmitter further away from the receiver—at least 6 m (20 ft)
- If you are using active antennas, reduce antenna or amplifier gain.
- Use omnidirectional antennas

## Reduce interference

- Perform a group or channel scan to find the best open frequency. Perform a sync to transfer the setting to the transmitter.
- For multiple systems, check that all systems are set to channels in the same group (systems in different bands do not need to be set to the same group).
- Maintain a line of sight between transmitter and receiver antennas.
- Move or point receiver antennas away from metal objects or other sources of RF interference (such as LED walls, computers, digital effects, network switches, network cables and Personal Stereo Monitor (PSM) wireless systems).
- Eliminate RF overload (see below).

## Increase Range

If the transmitter is more than 6 to 60 m (20 to 200 ft) from the receiver antenna, try the following to increase range:

- Reduce interference (see above).
- Increase transmitter RF power level.
- Use standard mode instead of high density mode.
- Use an active directional antenna, antenna distribution system, or other antenna accessory to increase RF range.

## Contact Customer Support

Didn't find what you need? [Contact our customer support](#) to get help.

## Specifications

### Mechanical

#### Dimensions

44 x 482 x 286 mm (1.7 x 19 x 11.3 inches), H x W x D

#### Weight

3.89 kg (8.58 lb), without antennas

#### Housing

Steel; Extruded aluminum

Case top: Aluminum

#### Operating Temperature Range

-18°C (0°F) to 50°C (122°F)

#### Storage Temperature Range

-29°C (-20°F) to 74°C (165°F)

#### Thermal Power Dissipation

<b>Maximum</b>	61.3 W (209.3 BTU/hr)
----------------	-----------------------

---

<b>Idle</b>	49.2 W (167.9 BTU/hr)
-------------	-----------------------

### Power Requirements

100 to 240 V AC, 50-60 Hz, 1.4 A max.

### Fuse

T5A

### PoE

PoE Class 1 (IEEE 802.3af)

### RF Input

### Spurious Rejection

>80 dB, typical

### Connector Type

BNC

### Impedance

50  $\Omega$

### Configuration

Unbalanced, passive

### Bias Voltage

12 to 13.5 V DC, 150 mA maximum per antenna. Switchable on-off. 300 mA total per receiver

### Insertion Loss

0 dB, typical

### RF and Audio Performance

### RF Carrier Frequency Range

174 - 2000 MHz

### Working Range

*Note: Actual range depends on RF signal absorption, reflection and interference.*

100 m (330 ft)

### Gain Adjustment Range

-18 to +42 dB in 1 dB steps (plus Mute setting)

### RF Tuning Step Size

25 kHz, varies by region

### Image Rejection

> 90 dB, typical

## RF Sensitivity

<b>ULX-D</b>	-95 dBm at $10^{-5}$ BER
<b>Axient Digital</b>	-93.5 dBm at $10^{-5}$ BER

## Latency

<b>ULX-D Standard</b>	< 2.9 ms
<b>ULX-D High Density</b>	< 3.2 ms
<b>Axient Digital Standard</b>	< 2.1 ms
<b>Axient Digital High Density</b>	< 3.0 ms

## Audio Frequency Response

20 Hz – 20 kHz ( $\pm 1$  dB)

## Audio Dynamic Range

*typical, 20 Hz to 20 kHz, System Gain @ +12 dB*

124 dB A-weighted

## Total Harmonic Distortion

*-6 dBFS, 1 kHz, System Gain @ +12 dB*

< 0.1%

## System Audio Polarity

Positive pressure on microphone diaphragm produces positive voltage on pin 2 (with respect to pin 3 of XLR output) and the tip of the 6.35 mm (1/4-inch) output.

## Headphone Monitor Audio Output

### Audio Frequency Response

20 Hz - 20 kHz, +/- 3 dB

## Configuration

1/4" / 6.3 mm connector, unbalanced stereo

## Impedance

63  $\Omega$

## Maximum Signal Level

350 mW

## Pin Assignments

Tip: Audio + , Left: | , Ring: Audio + , Right: | , Sleeve: Ground

## Networking

### Network Interface

10/100 Mbps, 1 Gbps, Dante Digital Audio

## Network Addressing Capability

DHCP or Manual IP address

## Maximum Cable Length

100 m (330 ft)

## DC Module Specifications

### DC Input Voltage Range

11.3 to 16 V DC, 10 A max.

### Maximum DC Input Current

5.5 A, 10 A max.

### Protection Modes

Reverse polarity, over voltage

### Connector Type

4-pin XLR (male)

The shell of the DC inlet XLR connector is connected to Chassis Ground.

## Recommended Cable Gauge

<b>3.5 feet or less</b>	18 AWG (1 mm <sup>2</sup> )
<b>4 to 6 feet</b>	16 AWG (1.5 mm <sup>2</sup> )
<b>7 to 10 feet</b>	14 AWG (2.5 mm <sup>2</sup> )

Important: Total cable length should not exceed 10 feet.

# Receiver Frequency Bands

## ULX-D<sup>®</sup> Mode

Band	Frequency Range ( MHz)
<b>AB</b>	A: 770 to 806
	<b>B: 806 to 809</b>
<b>G50</b>	470 to 534
<b>G51</b>	470 to 534
<b>G52</b>	479 to 534
<b>G53</b>	470 to 510
<b>G54</b>	479 to 565

<b>Band</b>	<b>Frequency Range ( MHz)</b>
<b>G55</b>	470 to 608, 614 to 636
<b>G56</b>	470 to 636
<b>G57</b>	470 to 608
<b>G62</b>	510 to 530
<b>G65</b>	470 to 606
<b>G66</b>	487 to 606
<b>H50</b>	534 to 598
<b>H51</b>	534 to 598
<b>H52</b>	534 to 565
<b>H54</b>	520 to 636
<b>J50</b>	572 to 608, 614 to 636
<b>J50A</b>	572 to 608, 614 to 616
<b>J51</b>	572 to 636
<b>JA</b>	770 to 806
<b>JB</b>	806 to 810
<b>K51</b>	606 to 670
<b>L50</b>	632 to 696
<b>L50A</b>	653 to 663
<b>L51</b>	632 to 696
<b>L53</b>	632 to 714
<b>M19</b>	695 to 703
<b>P51</b>	710 to 782
<b>Q12</b>	748 to 758
<b>Q51</b>	794 to 806
<b>R51</b>	800 to 810
<b>V50</b>	174 to 216
<b>V51</b>	174 to 216
<b>V52</b>	174 to 210
<b>X51</b>	925 to 937.5

Band	Frequency Range ( MHz)
Z16	1240 to 1260
Z17*	1492 to 1525
Z18	1785 to 1805
Z19†	1785 to 1800
Z20	1790 to 1805

\*The Z17 band must be used indoors only.

†When the Z19 band is used in Australia, per Radio Communications Low Interference Potential Devices Class License 2015; item 30 note C: the system must be operated within the range of 1790-1800MHz when used outdoors.

**Note:** Frequency bands might not be available for sale or authorized for use in all countries or regions.

## Axient® Digital Mode

Band	Frequency Range ( MHz)
G53	470 to 510
G54	479 to 565
G55†	470 to 636*
G56	470 to 636
G57	470 to 609
G57+*	470 to 609, 614 to 616
G62	510 to 530
G63	487 to 636
H54	520 to 636
JB	806 to 810
K53	606 to 608, 614 to 698
K54	606 to 608, 614 to 616, 653 to 663
K55	606 to 694
K56	606 to 714
K57	606 to 790
K58	622 to 698
L54	630 to 787
L60	630 to 698
P55	694 to 703, 748 to 758, 803 to 806

Band	Frequency Range ( MHz)
R52	794 to 806
X51	925 to 937.5
X55	941 to 960
X56	960 to 1000
Z16††	1240 to 1260

\* Maximum transmitter power is limited to 10mW between 614 to 616 MHz.

†Operation mode varies according to region. In Brazil, High Density mode is used. The maximum power level for Peru is 10mW.

††Z16 for Japan only

**Note:** Frequency bands might not be available for sale or authorized for use in all countries or regions.

## EU/UK Non-Harmonized Frequency Information



Country Code	Frequency Range
Code de Pays	Gamme de frequences
Codice di paese	Gamme di frequenza
Código de país	Gama de frecuencias
Länder-Kürzel	Frequenzbereich
AT, BE, BG, CH, CY, CZ, DE, DK, EE, ELES, FI, FR, HU, HR, IE, IS, IT, LT, LU, LV, LIMT, NL, NO, PL, PT, RO, SE, SI, SK, TR	174 MHz - 216 MHz * ** 470 MHz - 694MHz * ** 823 MHz - 832 MHz * ** 863 MHz - 865 MHz * ** 1492 MHz - 1525 MHz * ** 1785 MHz - 1804.8 MHz * **
UK, UK(NI)	174 MHz - 216 MHz * ** 470 MHz - 694MHz * ** 823 MHz - 832 MHz * ** 863 MHz - 865 MHz * **

Country Code	Frequency Range
Code de Pays	Gamme de frequences
Codice di paese	Gamme di frequenza
Código de país	Gama de frecuencias
Länder-Kürzel	Frequenzbereich
	960 MHz - 1154 MHz * ** 1785MHz - 1804.8 MHz * **
<b>all other countries</b>	*



\* This equipment may be capable of operating on some frequencies not authorized in your region. See [Licensing Information](#).

## Safety and Regulatory Information for Wireless Products

### Important Note

The complete Regulatory Notices for this product are available online. For complete Regulatory Information for your product, please check the soft copy of the product user guide at <http://www.shure.com/en-US/docs>.

### Explanation of Symbols

	This symbol indicates that dangerous voltage constituting a risk of electric shock is present within this unit.
	This symbol indicates that there are important operating and maintenance instructions in the literature accompanying this unit.



Supports multi-power supply input.

This symbol represents protective earth or protective ground and should not be disconnected.



### Important Safety Instructions

1. READ these instructions.
2. KEEP these instructions.
3. HEED all warnings.
4. FOLLOW all instructions.
5. DO NOT use this apparatus near water.
6. CLEAN ONLY with dry cloth.
7. DO NOT block any ventilation openings. Allow sufficient distances for adequate ventilation and install in accordance with the manufacturer's instructions.
8. DO NOT install near any heat sources such as open flames, radiators, heat registers, stoves, or other apparatus (including amplifiers) that produce heat. Do not place any open flame sources on the product.

9. DO NOT defeat the safety purpose of the polarized or grounding type plug. A polarized plug has two blades with one wider than the other. A grounding type plug has two blades and a third grounding prong. The wider blade or the third prong are provided for your safety. If the provided plug does not fit into your outlet, consult an electrician for replacement of the obsolete outlet.
10. PROTECT the power cord from being walked on or pinched, particularly at plugs, convenience receptacles, and the point where they exit from the apparatus.
11. ONLY USE attachments/accessories specified by the manufacturer.
12. USE only with a cart, stand, tripod, bracket, or table specified by the manufacturer, or sold with the apparatus. When a cart is used, use caution when moving the cart/apparatus combination to avoid injury from tip-over.



13. UNPLUG this apparatus during lightning storms or when unused for long periods of time.
14. REFER all servicing to qualified service personnel. Servicing is required when the apparatus has been damaged in any way, such as power supply cord or plug is damaged, liquid has been spilled or objects have fallen into the apparatus, the apparatus has been exposed to rain or moisture, does not operate normally, or has been dropped.
15. DO NOT expose the apparatus to dripping and splashing. DO NOT put objects filled with liquids, such as vases, on the apparatus.
16. The MAINS plug or an appliance coupler shall remain readily operable.
17. The airborne noise of the Apparatus does not exceed 70dB (A).
18. Apparatus with CLASS I construction shall be connected to a MAINS socket outlet with a protective earthing connection.
19. To reduce the risk of fire or electric shock, do not expose this apparatus to rain or moisture.
20. Do not attempt to modify this product. Doing so could result in personal injury and/or product failure.
21. Operate this product within its specified operating temperature range.
22. Follow local regulations and consult qualified personnel if the product installation or relocation requires construction work. Choose mounting hardware and an installation location that can support the weight of the product. Avoid locations subject to constant vibration. Use the required tools to install the product properly. Inspect the product periodically.

**WARNING:**

- Voltages in this equipment are hazardous to life. No user-serviceable parts inside. Refer all servicing to qualified service personnel. The safety certifications do not apply when the operating voltage is changed from the factory setting.
- If water or other foreign objects enter the inside of the device, fire or electric shock may result.

## Products with AC Adapters

1. Use only AC adapter that is provided with your product.
2. If this product is powered by an AC adapter other than the AC adapter that comes with your product, it could result in personal injury and/or product failure.

This equipment is not suitable for use in locations where children are likely to be present.

AC输入端保险丝：T250Vac, 5A, 仅限维修人员更换

# Important Product Regulatory Information

## Regulatory Information for Class B EMC Products

### CE Notice

Hereby, Shure Incorporated declares that this product with CE Marking has been determined to be in compliance with European Union requirements.

The full text of the EU declaration of conformity is available at the following site: <https://www.shure.com/en-EU/support/declarations-of-conformity>.

### UKCA Notice

Hereby, Shure Incorporated declares that this product with UKCA Marking has been determined to be in compliance with UK-CA requirements.

The full text of the UK declaration of conformity is available at the following site: <https://www.shure.com/en-GB/support/declarations-of-conformity>.

### Cybersecurity STATEMENT OF COMPLIANCE

**Product Type:** Relevant connectable products defined as internet-connectable products or network-connectable products, in line with inter alia Product Security and Telecommunications Infrastructure Act 2022.

**Manufacturer Statement:** We, Shure Incorporated, certify and declare as manufacturer under our sole responsibility, that the above-mentioned product(s) conform(s) to the legislation as mentioned under Attachment 1 – to Cybersecurity Statement of Compliance listed here: <https://www.shure.com/en-GB/about-us/security>.

**Information on how to report security issues:** The latest version of Shure's Disclosure policy can be found at the following link: <https://www.shure.com/en-GB/about-us/security>

**Security update periods:** Shure provides support regarding hardware and software updates that continue the integral cyber security safety of Shure products up to 24 months after end of life (AEOL). For the full statement regarding Shure's product support policy, and information regarding products end of life status information can be found at the following link: <https://www.shure.com/en-GB/about-us/security>

**Manufacturer:**

Shure Incorporated 5800 Touhy Avenue  
Niles, Illinois, 60714-4608 U.S.A. Website: [www.Shure.com](http://www.Shure.com).

**Technical documentation is kept at:**

Shure Incorporated, Corporate Global Compliance Engineering Division

**UK Importer/Representative:**

Shure UK Limited  
Unit 2, The IO Centre, Lea Road, Waltham Abbey, Essex, EN9 1AS, U.K.

Phone: +44 (0)1992 - 703058  
Email: EMEAsupport@shure.de

**On behalf of Manufacturer:**



Chad Ayers  
08 May 2025 Niles, Illinois  
Senior Director, Global Compliance

## FCC Notice

This equipment has been tested and found to comply with the limits for a Class B digital device pursuant to Part 15 of the FCC Rules. These limits are designed to provide reasonable protection against harmful interference when the equipment is operated in a residential installation. This equipment generates, uses, and can radiate radio frequency energy and, if not installed and used in accordance with the instructions, may cause harmful interference with radio communications. However, there is no guarantee that interference will not occur in a particular installation. If this equipment does cause harmful interference with radio or television reception, which can be determined by turning the equipment off and on, you are encouraged to try to correct the interference by one or more of the following measures:

- Reorient or relocate the antenna of the radio/television receiver.
- Increase the separation between this equipment and the radio/television receiver.
- Plug the equipment into a different outlet so that the equipment and the radio/television receiver are on different power mains branch circuits.
- Consult a representative of Shure or an experienced radio/television technician for additional suggestions.

This device complies with Part 15 of the FCC Rules. Operation is subject to the following two conditions:

1. This device may not cause harmful interference.
2. This device must accept any interference received, including interference that may cause undesired operation.

**Notice:** The FCC regulations provide that changes or modifications not expressly approved by Shure Incorporated could void your authority to operate this equipment.

For information regarding responsible party and other matters relating to FCC compliance, please contact Shure Incorporated, 5800 W. Touhy Avenue, Niles, Illinois 60714-4608 U.S.A. [shure.com/contact](https://www.shure.com/contact)

## Canada, ISED Notice

**Notice:** The Industry Canada regulations provide that changes or modifications not expressly approved by Shure Inc. could void your authority to operate this equipment.

This Class B digital apparatus complies with Canadian ICES-003. Cet appareil numérique de la classe B est conforme à la norme NMB-003 du Canada.

# Regulatory Information for Wireless Products

## Industry Canada (IC) Notices

This device contains licence-exempt transmitter(s)/receiver(s) that comply with Innovation, Science and Economic Development Canada's licence-exempt RSS(s). Operation is subject to the following two conditions:

1. This device may not cause interference.
2. This device must accept any interference, including interference that may cause undesired operation of the device.

L'émetteur/récepteur exempt de licence contenu dans le présent appareil est conforme aux CNR d'Innovation, Sciences et Développement économique Canada applicables aux appareils radio exempts de licence. L'exploitation est autorisée aux deux conditions suivantes :

1. L'appareil ne doit pas produire de brouillage;
2. L'appareil doit accepter tout brouillage radioélectrique subi, même si le brouillage est susceptible d'en compromettre le fonctionnement.

## ANATEL Notice

Este equipamento não tem direito à proteção contra interferência prejudicial e não pode causar interferência em sistemas devidamente autorizados. Para maiores informações, consulte o site da ANATEL – <http://www.anatel.gov.br>.

## IFETEL Notice

La operación de este equipo está sujeta a las siguientes dos condiciones: (1) es posible que este equipo o dispositivo no cause interferencia perjudicial y (2) este equipo o dispositivo debe aceptar cualquier interferencia, incluyendo la que pueda causar su operación no deseada.

## KCC Notice

해당 무선설비는 전파혼신 가능성이 있으므로 인명안전과 관련된 서비스는 할 수 없음

## NBTC Notice

เครื่องโทรคมนาคมและอุปกรณ์นี้มีความสอดคล้องตามมาตรฐานหรือข้อกำหนดทางเทคนิคของ กสทช.

## NCC Notice

Connection and use of this communications equipment is permitted by the Nigerian Communications Commission.

## NCC Notice

低功率射頻器材技術規範

取得審驗證明之低功率射頻器材，非經核准，公司、商號或使用者均不得擅自變更頻率、加大功率或變更原設計之特性及功能。低功率射頻器材之使用不得影響飛航安全及干擾合法通信；經發現有干擾現象時，應立即停用，並改善至無干擾時方得繼續使用。前述合法通信，指依電信管理法規定作業之無線電通信。低功率射頻器材須忍受合法通信或工業、科學及醫療用電波輻射性電機設備之干擾。

614MHz-703MHz: 使用頻段供其他通訊業務使用時，器材應即停止使用

## SRRC Notice

- (一) 本产品符合“微功率短距离无线电发射设备目录和技术要求”的具体条款和使用场景；
- (二) 不得擅自改变使用场景或使用条件、扩大发射频率范围、加大发射功率（包括额外加装射频功率放大器），不得擅自更改发射天线；
- (三) 不得对其他合法的无线电台（站）产生有害干扰，也不得提出免受有害干扰保护；
- (四) 应当承受辐射射频能量的工业、科学及医疗（ISM）应用设备的干扰或其他合法的无线电台（站）干扰；
- (五) 如对其他合法的无线电台（站）产生有害干扰时，应立即停止使用，并采取措施消除干扰后方可继续使用；
- (六) 在航空器内和依据法律法规、国家有关规定、标准划设的射电天文台、气象雷达站、卫星地球站（含测控、测距、接收、导航站）等军民用无线电台（站）、机场等的电磁环境保护区域内使用微功率设备，应当遵守电磁环境保护及相关行业主管部门的规定。

## ACMA Notice

WARNING: This device operates under an ACMA class license and must comply with all conditions of that license including operating frequencies.

## Environmental Regulatory Information

### Waste Electrical and Electronic Equipment (WEEE) Directive



In the European Union and the United Kingdom, this label indicates that this product should not be disposed of with household waste. It should be deposited at an appropriate facility to enable recovery and recycling.

### Registration, Evaluation, Authorization of Chemicals (REACH) Directive

REACH (Registration, Evaluation, Authorization of Chemicals) is the European Union (EU) and the United Kingdom (UK) chemical substances regulatory framework. Information on substances of very high concern contained in Shure products in a concentration above 0.1% weight over weight (w/w) is available upon request.

## Recycling Information

Please consider the environment, electric products and packaging are part of regional recycling schemes and do not belong to regular household waste.

## 中国 RoHS

部件名称	有害物质									
	Pb	Cd	Hg	Cr(VI)	PBB	PBDE	DBP	BBP	DIBP	DEHP
电路模块	X	○	○	○	○	○	○	○	○	○
金属模块	X	○	○	○	○	○	○	○	○	○
线缆及其组件	X	○	○	○	○	○	○	○	○	○
电源适配器*	X	○	○	○	○	○	○	○	○	○
锂电池组*	X	○	○	○	○	○	○	○	○	○

注1: ○: 表示该有害物质在该部件所有均质材料中的含量均不出电器电子产品有害物质限制使用国家标准要求。  
X: 表示该有害物质至少在该部件某一均质材料中的含量超出电器电子产品有害物质限制使用国家标准要求。  
注2: 本产品大部分的部件采用无害的环保材料制造, 含有有害物质的部件皆因全球技术发展水平的限制而无法实现有害物质的替代。  
注3: 以上未列出的部分, 表明其有害物质含量均不出电器电子产品有害物质限制使用国家标准要求  
\*: 表示如果包含部分

---

# Certifications

## Regulatory Model Number (RMN)

For regulatory identification purposes your product has been assigned a regulatory model number (RMN). This regulatory model number should not be confused with product number, as below.

<b>RMN: ANX4</b>	<b>Product Numbers: ANX4, ANX4 DC</b>
------------------	---------------------------------------

## Certification and Compliance Markings

