



# SCENE SETTER

## User Guide

©2023 ADJ Products, LLC all rights reserved. Information, specifications, diagrams, images, and instructions herein are subject to change without notice. ADJ Products, LLC logo and identifying product names and numbers herein are trademarks of ADJ Products, LLC. Copyright protection claimed includes all forms and matters of copyrightable materials and information now allowed by statutory or judicial law or hereinafter granted. Product names used in this document may be trademarks or registered trademarks of their respective companies and are hereby acknowledged. All non-ADJ Products, LLC brands and product names are trademarks or registered trademarks of their respective companies.

**ADJ Products, LLC** and all affiliated companies hereby disclaim any and all liabilities for property, equipment, building, and electrical damages, injuries to any persons, and direct or indirect economic loss associated with the use or reliance of any information contained within this document, and/or as a result of the improper, unsafe, insufficient and negligent assembly, installation, rigging, and operation of this product.

**ADJ USA** | 6122 S. Eastern Ave. | Los Angeles, CA. 90040

323-582-2650 | 323-532-2941 fax | [www.adj.com](http://www.adj.com) | [support@americandj.com](mailto:support@americandj.com)

**ADJ Supply Europe B.V.** | Junostraat 2 | 6468 EW Kerkrade, The Netherlands

+31 (0)45 546 85 00 | +31 45 546 85 99 fax | [www.adj.eu](http://www.adj.eu) | [support@adjgroup.eu](mailto:support@adjgroup.eu)

**ADJ Mexico** | AV Santa Ana 30 | Parque Industrial Lerma, Lerma, Mexico 52000

+52 (728) 282-7070

## DOCUMENT VERSION



Due to additional product features and/or enhancements, an updated version of this document may be available online.

Please check [www.adj.com](http://www.adj.com) for the latest revision/update of this manual

Date	Document Version	DMX Channels	Notes
10/29/2016	1.0	N/A	Initial Release
05/31/2022	1.5	N/A	Update format
4/06/2023	2.0	N/A	Added USB stick instructions

# CONTENTS

Introduction	4
Limited Warranty (USA Only)	5
Features	6
Safety Guidelines	7
Overview	8
Operation Guide	12
1. Begin Programming	12
1.1 Record Enable	12
1.2 Security for Your Programs	12
1.3 Program Scenes	13
2. Editing	15
2.1 Edit Enable	15
2.2 Erase a Program	16
2.3 Erase All Programs	16
2.4 Clear a Scene or Scenes	17
2.5 Delete a Step or Steps	17
2.6 Insert a Step or Steps	18
2.7 Modify a Step or Steps	19
3. Running	20
3.1 Running Chase Programs	20
3.2 Running a Program to Audio	21
3.3 Running a Program with the Speed Slider	21
3.4 Running a Program with Standard Beat	22
3.5 Changing the Speed Mode Between 5 and 10 Minutes	22
MIDI Operation	23
1. Setting MIDI In	23
2. Setting MIDI Out	23
3. Exit MIDI Setting	23
4. Receiving MIDI File Dump	24
5. Sending MIDI File Dump	24
6. Implementation	25
DMX Channels	26
1. DMX Channel Setup	26
1.1 Add/Assign DMX Channel	26
1.2 Remove DMX Channel	26
1.3 Assign All Console Channels to a Single DMX Channel	26
2. Clear DMX Channel Setup	26
3. Call 12 Pre-Set Programs	26
Brief of Main Functions	27
Quick Reference Guide	29
USB Stick: Saving Files / Loading Files / Software Update	31
Specifications	32

# INTRODUCTION

**Unpacking:** Thank you for purchasing the Scene Setter by ADJ Products, LLC. Every device has been thoroughly tested and has been shipped in perfect operating condition. Carefully check the shipping carton for damage that may have occurred during shipping. If the carton appears to have been damaged, carefully inspect your device for any damage and be sure all accessories necessary to operate the device have arrived intact. In the event that damage has been found or parts are missing, please contact our toll free customer support number for further instructions. Do not return this device to your dealer without first contacting customer support.

**These instructions contain important safety information regarding the use and maintenance of this unit. Please keep this manual with the unit for future reference.**

Customer Support: Contact ADJ Service for any product related service and support needs. Also visit [forums.adj.com](http://forums.adj.com) with questions, comments or suggestions.

**Parts:** To purchase parts online visit:

<http://parts.adj.com> (US)

<http://www.adjparts.eu> (EU)

**ADJ SERVICE USA - Monday - Friday 8:00am to 4:30pm PST**

Voice: 800-322-6337 | Fax: 323-582-2941 | [support@adj.com](mailto:support@adj.com)

**ADJ SERVICE EUROPE - Monday - Friday 08:30 to 17:00 CET**

Voice: +31 45 546 85 60 | Fax: +31 45 546 85 96 | [support@adj.eu](mailto:support@adj.eu)

**ADJ PRODUCTS LLC USA**

6122 S. Eastern Ave. Los Angeles, CA. 90040

323-582-2650 | Fax 323-532-2941 | [www.adj.com](http://www.adj.com) | [info@adj.com](mailto:info@adj.com)

**ADJ SUPPLY Europe B.V**

Junostraat 2 6468 EW Kerkrade, The Netherlands

+31 (0)45 546 85 00 | Fax +31 45 546 85 99

[www.americandj.eu](http://www.americandj.eu) | [info@americandj.eu](mailto:info@americandj.eu)

**ADJ PRODUCTS GROUP Mexico**

AV Santa Ana 30 Parque Industrial Lerma, Lerma, Mexico 52000

+52 (728) 282-7070

**CAUTION!** There are no user serviceable parts inside this unit. Do not attempt any repairs yourself, as doing so will void your manufacturer's warranty. In the unlikely event your unit may require service, please contact ADJ Products, LLC.

Do not discard the shipping cartoon in the trash. Please recycle when ever possible.

## LIMITED WARRANTY (USA ONLY)

- A. ADJ Products, LLC hereby warrants, to the original purchaser, ADJ Products, LLC products to be free of manufacturing defects in material and workmanship for a prescribed period from the date of purchase (see specific warranty periods below). This warranty shall be valid only if the product is purchased within the United States of America, including possessions and territories. It is the owner's responsibility to establish the date and place of purchase by acceptable evidence, at the time service is sought.
- B. For warranty service you must obtain a Return Authorization number (RA#) before sending back the product—please contact ADJ Products, LLC Service Department at 800-322-6337. Send the product only to the ADJ Products, LLC factory. All shipping charges must be pre-paid. If the requested repairs or service (including parts replacement) are within the terms of this warranty, ADJ Products, LLC will pay return shipping charges only to a designated point within the United States. If the entire instrument is sent, it must be shipped in its original package. No accessories should be shipped with the product. If any accessories are shipped with the product, ADJ Products, LLC shall have no liability whatsoever for loss of or damage to any such accessories, or for the safe return thereof.
- C. This warranty is void if the serial number has been altered or removed; if the product is modified in any manner which ADJ Products, LLC concludes, after inspection, affects the reliability of the product; if the product has been repaired or serviced by anyone other than the ADJ Products, LLC factory unless prior written authorization was issued to purchaser by ADJ Products, LLC; if the product is damaged because not properly maintained as set forth in the instruction manual.
- D. This is not a service contract, and this warranty does not include maintenance, cleaning or periodic checkup. During the period specified above, ADJ Products, LLC will replace defective parts at its expense with new or refurbished parts and will absorb all expenses for warranty service and repair labor by reason of defects in material or workmanship. The sole responsibility of ADJ Products, LLC under this warranty shall be limited to the repair of the product, or replacement thereof, including parts, at the sole discretion of ADJ Products, LLC. All products covered by this warranty were manufactured after August 15, 2012, and bear identifying marks to that effect.
- E. ADJ Products, LLC reserves the right to make changes in design and/or improvements upon its products without any obligation to include these changes in any products theretofore manufactured. No warranty, whether expressed or implied, is given or made with respect to any accessory supplied with products described above. Except to the extent prohibited by applicable law, all implied warranties made by ADJ Products, LLC in connection with this product, including warranties of merchantability or fitness, are limited in duration to the warranty period set forth above. And no warranties, whether expressed or implied, including warranties of merchantability or fitness, shall apply to this product after said period has expired. The consumer's and/or Dealer's sole remedy shall be such repair or replacement as is expressly provided above; and under no circumstances shall ADJ Products, LLC be liable for any loss or damage, direct or consequential, arising out of the use of, or inability to use, this product. This warranty is the only written warranty applicable to ADJ Products, LLC Products and supersedes all prior warranties and written descriptions of warranty terms and conditions heretofore published.

### LIMITED WARRANTY PERIODS

- **Non-LED Lighting Products = 1-Year (365 Days)** (Including Special Effect Lighting, Intelligent Lighting, UV lighting, Strobes, Fog Machines, Bubble Machines, Mirror Balls, Par Cans, Trussing, Lighting Stands, Power/Data Distribution, etc. excluding LED and lamps)
- **Laser Products = 1-Year (365 Days)** (excluding laser diodes which have a 6-Month Limited Warranty)
- **LED Products = 2-Year (730 Days)** (excluding batteries which have a 180 Day Limited Warranty)  
**PLEASE NOTE: 2-Year (730 Days) Limited Warranty ONLY applies to product purchased within the USA.**
- **StarTec Series = 1-Year (365 Days)** (excluding batteries which have a 180 Day Limited Warranty)
- **ADJ DMX Controllers = 2 Year (730 Days)**
- **American Audio Products = 1 Year (365 Days)**

# FEATURES

- 24 channel conventional dimming console Two scene operation (A/B faders)
- 11,000 programmable scenes- password protected
- 48 programmable chases (stacks)- password protected Up to 1,000 scenes (steps) per chase
- 12 x 4 Pages = 48 total chases
- Solo & Pile On chase operation
- Blind & Dark functions
- 24 individual channel faders
- 24 bump buttons
- Tap Sync button for chase speed / fade override Independent speed & fade control
- Full-On button for 100% momentary output to all 24 channels Bright LCD display
- Use in conjunction with the ADJ or Elation: DP-DMX20L, CYBER PAK, UNI PAK-II, UNI BAR, DP-415, DP-640, RMD620 & RMD1210
- Line level audio input and built in microphone for music sync operation
- Audio level fader
- Fog Machine input and trigger button- compatible with ADJ Vaporizer, MB-1000, Stallion, Vapor-Flow, Fog Storm-1200 & 1700 DMX Polarity switch (2-, 3+, / 2+, 3-)
- Midi In, Out & Thru connectors

# SAFETY GUIDELINES

Read the instructions in this manual carefully and thoroughly, as they contain important information regarding safety during operation and maintenance. Keep this manual with the unit for future reference. If the unit is sold or given to another operator, make certain that the new operator receives the manual as well.

- **DO NOT** spill any flammable liquids, water, or any other kind of fluids into the device.
- Should any liquid be spilled on the unit, **DISCONNECT** the power supply to the unit immediately.
- **DO NOT** insert any metal objects into the device.
- If serious operational problems arise, discontinue use of the device immediately and contact the dealer or the manufacturer immediately for assistance.
- **DO NOT** open the unit for any reason. There are no user serviceable parts inside.
- **NEVER** attempt to perform repairs to the unit yourself, as doing so could result in damage or faulty operation, and may void your manufacturer's warranty. Contact your nearest dealer for assistance.
- This unit is **NOT** intended for home use.
- After removing the packaging, inspect the unit for any damage. **DO NOT** operate the device if it has been damaged in any way. Contact a dealer for assistance.
- Packaging material (plastic bags, polystyrene foam, nails, etc.) **MUST NOT** be left within children's reach, as it can create a safety hazard.
- This unit should only be operated by qualified adults and personnel. **DO NOT** allow children to tamper or play with the device.
- **DO NOT** dismantle or modify the unit.
- Protect the device from excessive dryness or humidity. Ideal humidity conditions are between 35% and 80%.
- **NEVER** use the unit under the following conditions:
  - A. In places subject to excessive humidity.
  - B. In places subject to vibrations or bumps.
  - C. In places where the temperature above falls outside the ambient temperature range of **35° F to 113° F (2° C to 45° C)**.

# OVERVIEW

## FRONT VIEW

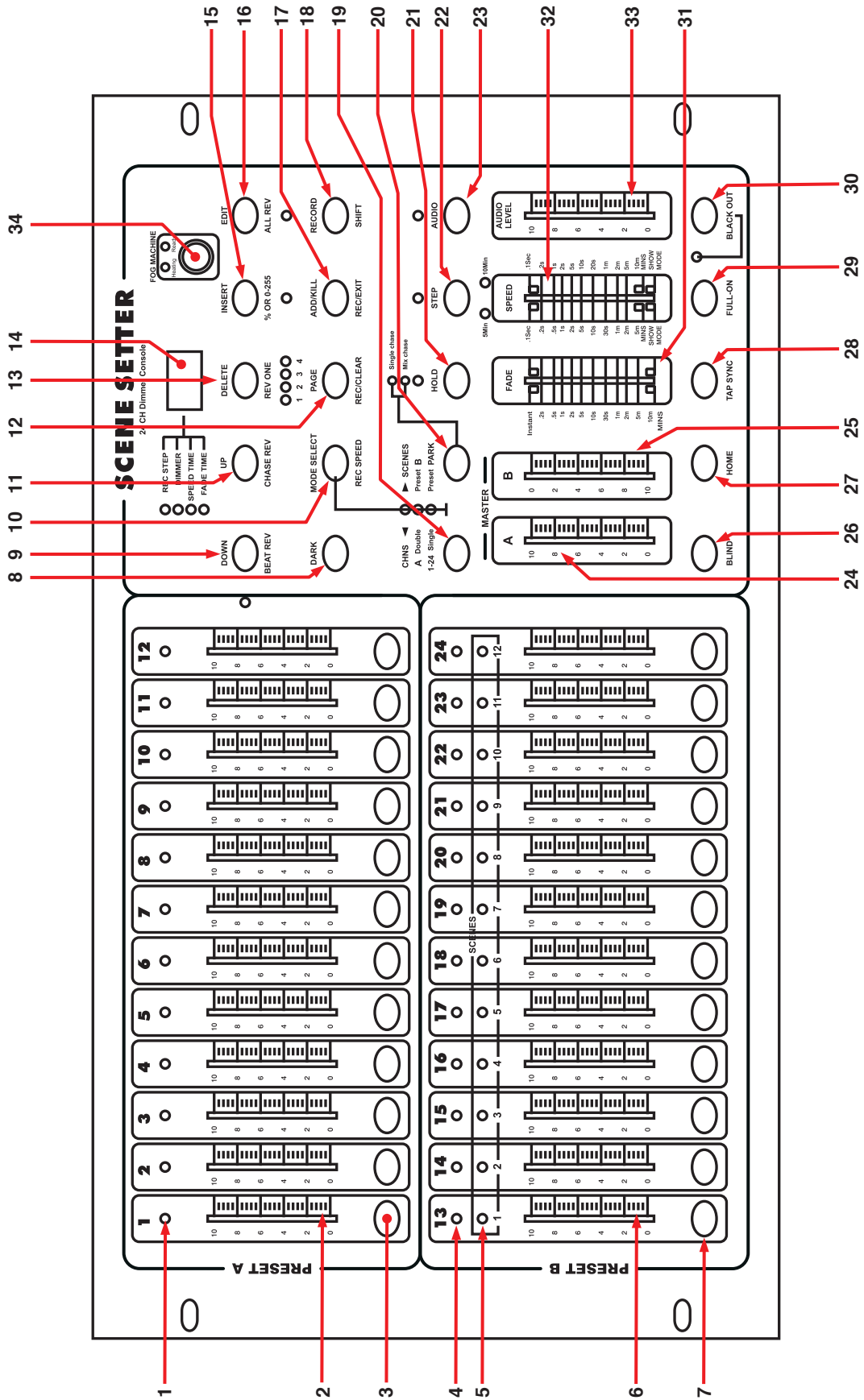

# OVERVIEW

## FRONT VIEW

Diagram No.	Feature	Description
1	Preset A LEDs	Show the current intensity of the relevant channel numbered from 1 to 12.
2	Channel Sliders 1-12	These 12 sliders are used to control and/or program the intensities of channels 1-24.
3	Flash Buttons 1-12	These 12 buttons are used to bring an individual channel to full intensity.
4	Preset B LEDs	Show the current intensity of the relevant channel numbered from 13-24.
5	Scene LEDs	Light when relevant scenes are active.
6	Channel Sliders 12-24	These 24 sliders are used to control and/or program the intensities of channels 12-24.
7	Flash Buttons 25-48	These 12 buttons are used to bring an individual channel to full intensity. Also used from programming.
8	Dark Button	This button is used to momentarily black out overall output.
9	Down / Beat Rev	DOWN functions to modify a scene in Edit mode; BEAT REV is used to reverse the chasing direction of a program with regular beat.
10	Mode Select / Rec Speed	Each tap will activate the operating mode in the following order: CHNS/SCENES, Double Preset, and Single Preset. Rec Speed: Set the speed of any of the programs chasing in Mix mode.
11	Up / Chase Rev	Up is used to modify a scene in Edit mode. Chase Rev is used to reverse the chasing direction of a scene under Speed Slider control.
12	Page Button	Tap to select pages of scenes from Page 1-4.
13	Delete / Rev One	Delete any step of a scene or reverse the chasing direction of any program.
14	Segment Display	Shows the current activity or programming state.
15	Insert / % or 0-255	Insert is to add one step or multiple steps into a scene. % or 0-255 is used to toggle the display value between % and 0-255.
16	Edit / All Rev	Edit is used to activate Edit mode. All Rev is used to reverse the chasing direction of all programs.
17	Add or Kill / Rec Exit	In Add mode, multiple scenes or Flash buttons will be on at the same time. In Kill mode, pressing any Flash button will kill any other scenes or programs. Rec Exit is used to exit from Program or Edit mode.

# OVERVIEW

## FRONT VIEW

Diagram No.	Feature	Description
18	Record / Shift	Record is used to activate Record mode or program a step. Shift functions only used with other buttons.
19	Master A Button	Brings channel 1-12 to full of current setting.
20	Park Button	Used to select Single/Mix Chase, bring Channel 13-24 to full of current setting, or momentarily program a scene into Master B slider, depending on the current mode.
21	Hold Button	This button is used to maintain current scene.
22	Step Button	This button is used to go to next step when the Speed Slider is pushed to the bottom or in Edit mode.
23	Audio Button	Activates audi sync of chase and audio intensity effects.
24	Master Slider A	This slider controls overall output of all channels.
25	Master Slider B	This slider control the chase of all programs.
26	Blind Button	This function takes the channel out of the chase of a program in CHNS/SCENE mode.
27	Home Button	This button is used to deactivate the Blind.
28	Tap Sync Button	Repeatedly tapping this button establishes the chase speed.
29	Full On Button	This function brings overall output to full intensity.
30	Black Out Button	This button is used to kill all output except for output resulting from Flash and Full On.
31	Fade Time Slider	Used to adjust the Fade Time.
32	Speed Slider	Used to adjust chase speed.
33	Audio Level Slider	This slider controls the sensitivity of the Audio input.
34	Fog Machine Button	This button control the fog machine function.

# OVERVIEW

## REAR VIEW

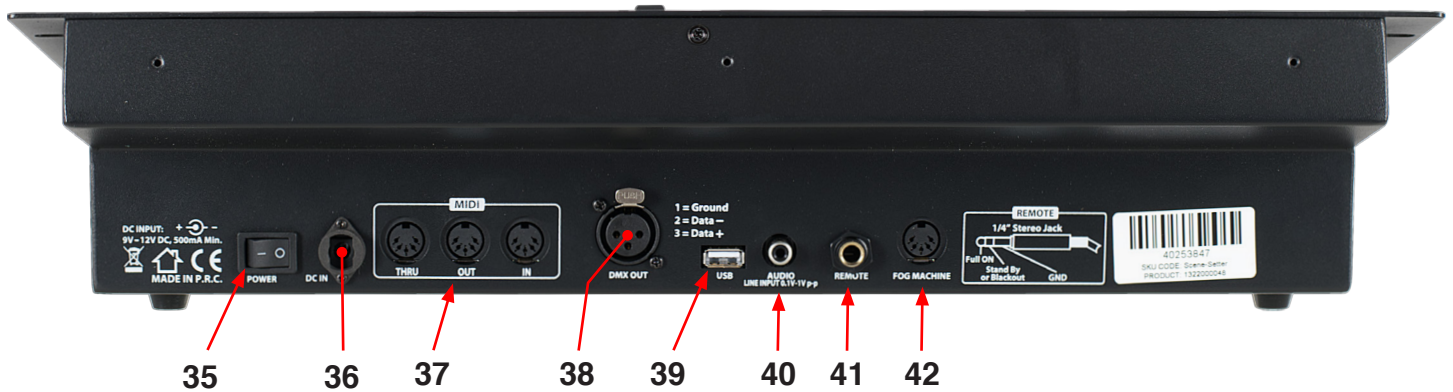

Diagram No.	Feature	Description
35	Power Switch	This switch is used to turn power on or off.
36	DC Input	DC 12-20V, 500 mA-min.
37	MIDI Thru / Out / In	MIDI ports for connection to a sequencer or MIDI device.
38	DMX Out	This connector sends your DMX value to the DMX fixture of DMX pack.
39	USB Port	Used to update software or load memory files
40	Audio Input	This jack accepts a line level audio input signal ranged from 100mV to 1Vpp.
41	Remote Input	Black Out and Full On may be controlled by a remote control using a standard 1/4" stereo jack.
42	Fog Machine Connector	Connector port for a fog machine.

# OPERATION GUIDE

## 1. BEGIN PROGRAMMING

### 1.1 Record Enable.

1. Press and hold the Record button.
2. While holding down the Record button, tap Flash buttons 1, 6, 6 and 8 in sequence.
3. Release the Record button, and the Record LED will illuminate. You can now begin programming your chase patterns.

**NOTE:** The first time you turn on your unit, the default setting of the Record Code is Flash buttons 1, 6, 6 and 8. You may change the Record Code to protect your programs.

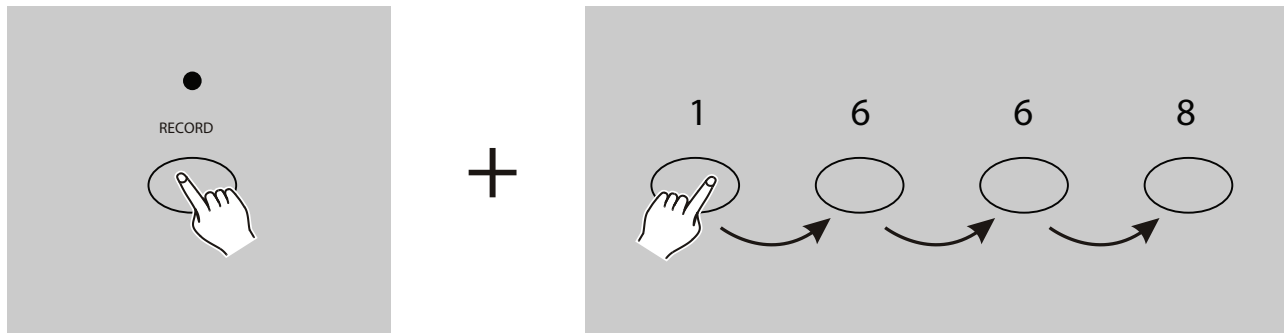

### 1.2 Security for Your Programs.

To protect your programs from any unauthorized changes, you may change the Record Code.

1. Enter current Record Code (Default code: Flash buttons 1, 6, 6 and 8).
2. Press and hold down the Record and Edit buttons at a time.
3. While holding the Record and Edit buttons, tap the desired Flash button to enter a new Record Code. The Record Code consists of 4 Flash buttons, and may include repeat numbers, if desired.
4. Enter your new Record Code a second time. If the change was successful, all channel LEDs and scene LEDs will flash three times.
5. Exit Record mode. Tap the Rec Exit button while pressing and holding down the Record button, then release both buttons at the same time. Record mode is now disengaged.

### **IMPORTANT!**

**Always remember to exit Record mode when you have finished programming, in order to avoid inadvertently losing control of your unit.**

**NOTE:** When setting a new Record Code, this change can be canceled as long as you have not completed Step 4 above (entering the new Record Code a second time). To cancel the change at this time, press and hold the Record and Exit buttons together to exit without making the change.

# OPERATION GUIDE

## 1.3 Program Scenes.

1. Activate Record Enable, as described in the **Record Enable** section.
2. Select the 1-24 Single mode by tapping the the Mode Select button. This will give you control of all 24 channels as you program. Be sure that Master A & B are both set at maximum. (Master A is at its maximum in the fully up position, while Master B is at its maximum in the fully down position.)

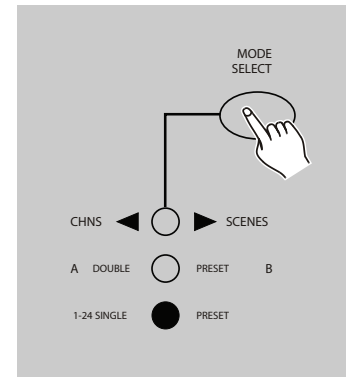

3. Create a desired scene using Channel Sliders 1-24. At 0% or DMX 0, these sliders should be at 0 position, and at 100% or DMX 255, these sliders should be at 10 position.

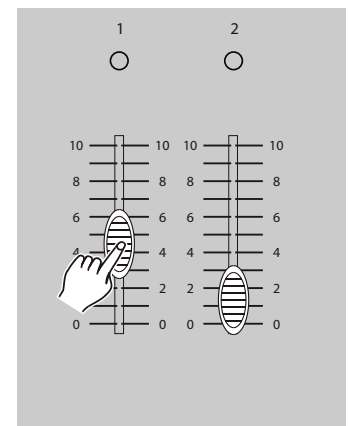

4. Once the scene is satisfactory, tap the Record button to program the scene into the memory as a step.
5. Repeat steps 3 and 4 until all desired steps have been programmed into memory. You may program up to 1000 steps into memory.

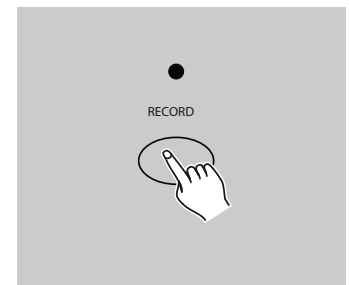

6. Select a chase bank or scene master to store your program. Tap the Page button to select a page (Page 1-4) to store your scenes.

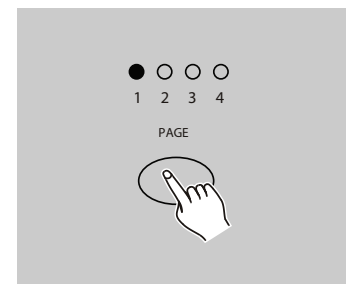

# OPERATION GUIDE

## 1.3 Program Scenes.

7. Press a Flash button between 25-48 while holding down the Record button. All LEDs will flash to indicate that the scenes have been programmed into memory.

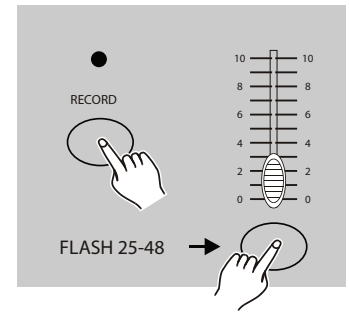

8. You can continue programming, or exit. To exit Program mode, tap the Exit button while holding down the Record button. The Record LED should turn off to indicate that the device is no longer in Program mode.

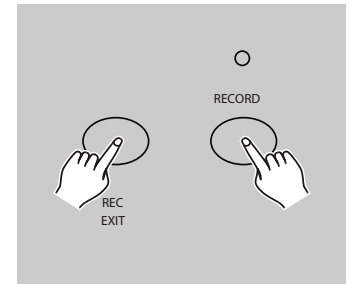

**Example:** Program a 16 steps chase with channel 1-16 at full in sequence into Flash button 15 of Page 1:

1. Record enable.
2. Push Master A & B to maximum position, and push Fade slider to the top.
3. Tap the Mode Select button to select 1-24 Single mode.
4. Push Channel slider 1 to the top position. The slider's LED light should be at full intensity.
5. Tap the Record button to program this step into memory.
6. Repeat steps 4 and 5 until you have assigned programs to Channel sliders 1-16.
7. Tap the Page button causing Page 1 LED lights.
8. Tap Flash button 15 while holding down the Record button. All LEDs will flash to indicate that you have programmed the chase into memory.

# OPERATION GUIDE

## 2. EDITING

### 2.1 Edit Enable.

1. Activate Record Enable, as described in the **Record Enable** section.
2. Use the Page button to select the page where the program you wish to edit is located.
3. Tap the Mode Select button to select CHNS or SCENES.

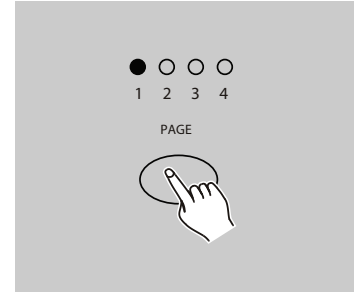

3. Tap the Mode Select button to select CHNS or SCENES.

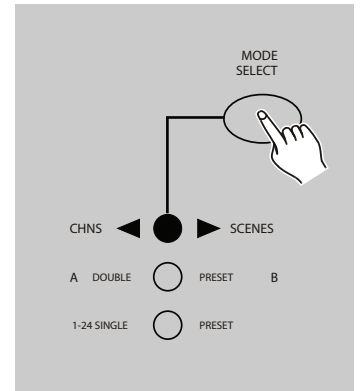

4. Press and hold the Edit button.

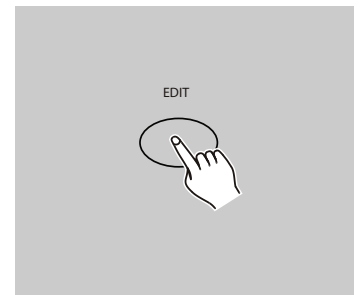

5. While holding down the Edit button, tap the Flash button that corresponds to the program that you wish to edit.
6. Release the Edit button. The relevant scene LED should illuminate, indicating that the device is in Edit mode,

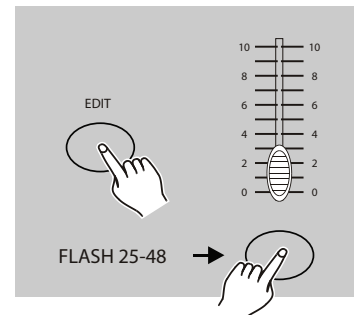

# OPERATION GUIDE

## 2.2 Erase a Program.

1. Activate Record Enable, as described in the **Record Enable** section.
2. Use the Page button to select the page where the program you wish to erase is located.
3. Hold down the Edit button, and tap the Flash button (13-24) twice.
4. Release both the Edit and Flash button (13-24). All LEDs should flash to indicate the program has been successfully erased.

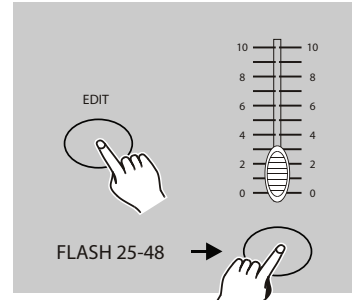
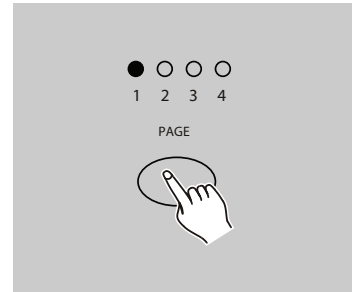

Tap this button twice

## 2.3 Erase All Programs.

1. Press and hold the Record button.
2. Tap the Flash buttons 1, 4, 2 and 3 in sequence while holding the Record button. All LEDs will flash, indicating all programs stored in memory have been erased.

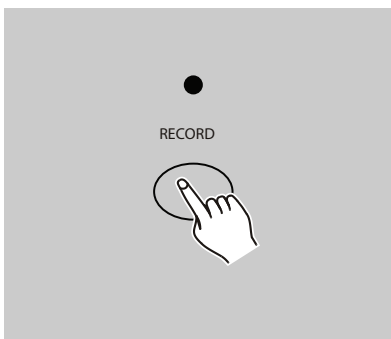

+

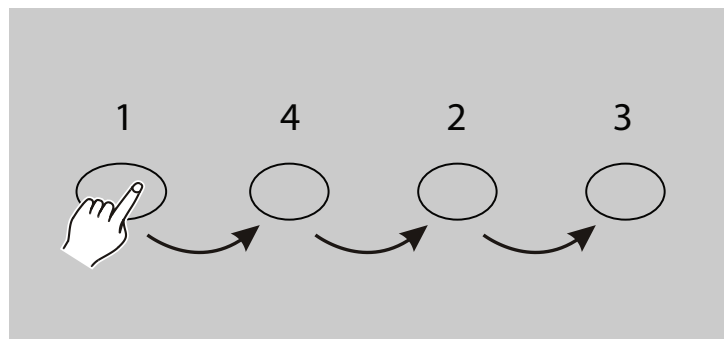

## 2.4 Clear a Scene or Scenes.

1. Activate Record Enable, as described in the **Record Enable** section.
2. Record a scene or scenes.
3. If you wish to delete these recorded scens, tap the Rec Clear button while pressing and holding the Record button. All LEDs will flash, indicating that the scenes have been cleared.

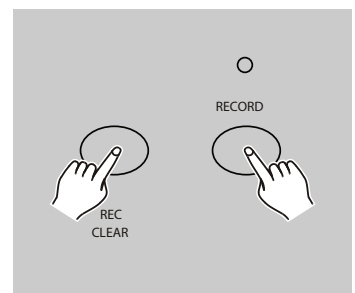

# OPERATION GUIDE

## 2.5 Delete a Step or Steps.

1. Enter the Edit mode.
2. Tap the Step button to scroll to the step you wish to delete.
3. Tap the Delete button when you reach the step you wish to delete. All LEDs will flash briefly to indicate that the step has successfully been deleted.
4. Repeat steps 2 and 3 until all unwanted steps have been deleted.
5. Tap the Rec Exit button while pressing and holding the Record button. The Scene LED should turn off, indicating that the device is no longer in Edit mode.

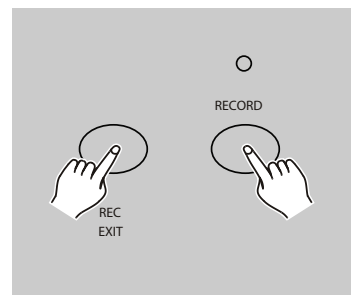
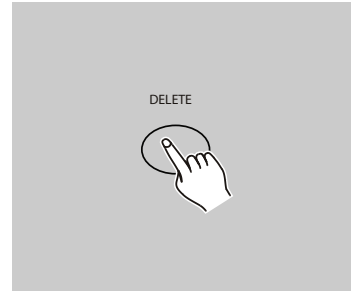
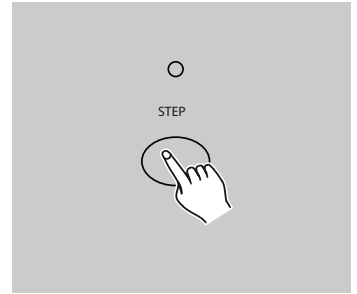

**Example:** Delete the third step of the program on Flash button 15 on Page 2.

1. Record enable.
2. Tap the Mode Select button to select CHNS or SCENE mode.
3. Tap the Page button until Page 2 LED lights
4. Tap the Flash button 15 while pressing and holding down the Edit button, the Scene LED lights.
5. Tap the Step button to scroll the third step.
6. Tap the Delete button to delete the step.
7. Tap the Rec Exit button while pressing and holding down the Record button to exit Edit mode.

# OPERATION GUIDE

## 2.6 Insert a Step or Steps.

1. Record a scene or scenes you wish to insert.
2. Be sure that the device is in CHNS SCENE and enter the Edit mode.
3. Tap the Step button to scroll to the where you wish to insert the new step. **The new step will be inserted before the step that is shown on the display screen.**



4. Tap the Insert button to insert the step. All LEDs will flash, indicating the step has been successfully inserted.
5. Exit Edit mode.

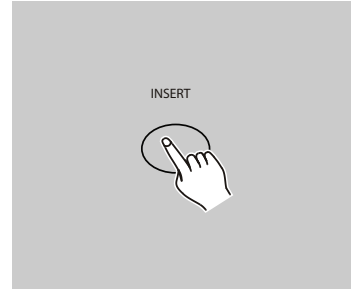

**Example:** Insert a step with channels 1-12 fully on at a time between step 4 and step 5 of program 35.

1. Record enable.
2. Tap the Mode Select button to select CHNS or SCENE mode.
3. Tap the Page button until Page 2 LED lights
4. Tap the Flash button 15 while pressing and holding down the Edit button, the Scene LED lights.
5. Tap the Step button to scroll the third step.
6. Tap the Delete button to delete the step.
7. Tap the Rec Exit button while pressing and holding down the Record button to exit Edit mode.

# OPERATION GUIDE

## 2.7 Modify a Step or Steps.

1. Enter Edit mode.
2. Tap the Step button to scroll to the step you wish to modify.
3. Press and hold the Up button to raise the intensity, or press and hold down the Down button to lower the intensity.
4. While holding down the Up or Down button, tap the Flash button corresponding to the DMX channel of the scene you wish to modify until the desired intensity value is shown on the segment display. Tap the Flash buttons until you are satisfied with the new scene.
5. Repeat steps 2, 3, and 4 until all steps of the program have been modified.
6. Exit the Edit mode.

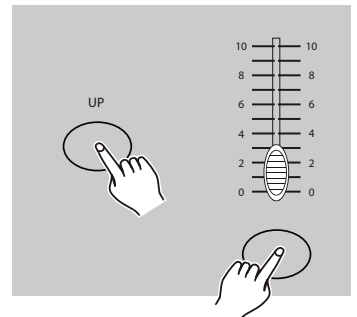
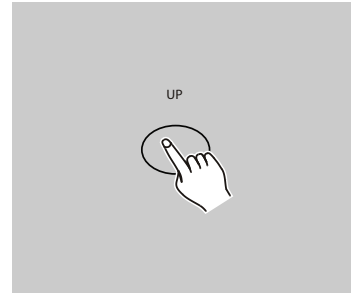
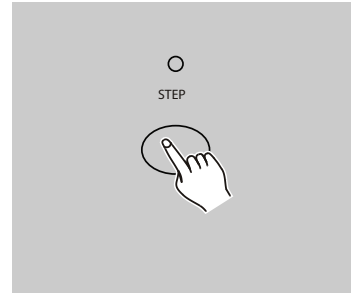

# OPERATION GUIDE

## 3. RUNNING

### 3.1 Running Chase Programs.

1. Tap the Mode Select button to select **CHNS SCENE** mode as indicated by the LED.

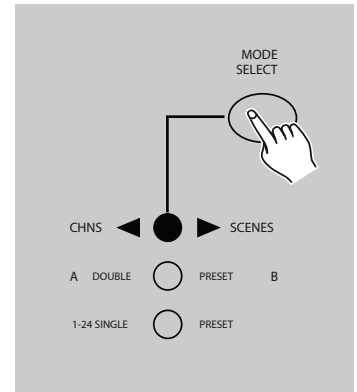

2. Tap the Page button to select the page where the program you wish to run is located.

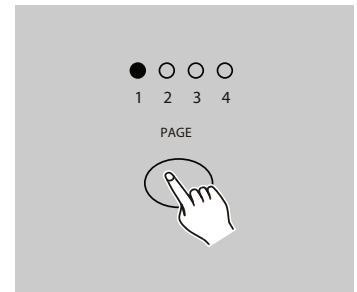

3. Push Master Slider B to its maximum position (fully down).

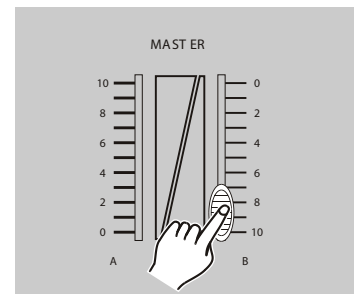

4. Move the desired Channel Slider (13-24) to its maximum position to trigger the program, which will then fade in according to the currently set fade time. You may press and hold the relevant Flash button (13-24) to trigger the program.

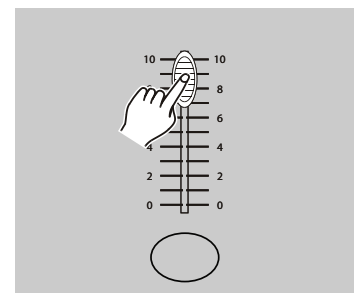

5. Move the Channel slider to adjust the output of the current program.

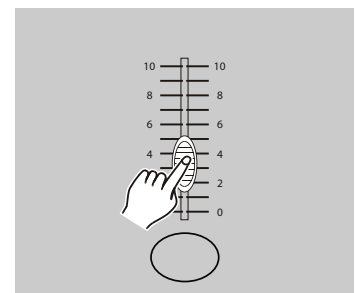

# OPERATION GUIDE

## 3.2 Running a Program to Audio.

1. Use built-in microphone, or plug the audio source into the RCA Audio jack.
2. Select your program as described above.
3. Tap the Audio button. Its LED will illuminate, indicating Audio mode is active.

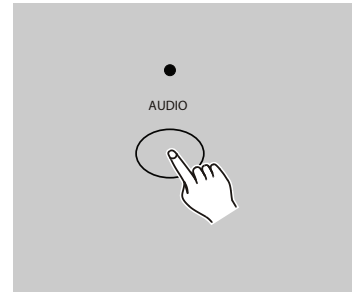

4. Use the Audio Level slider to adjust the music sensitivity.

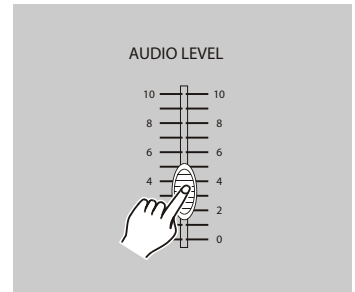

5. To return to normal mode, tap the Audio button a second time. The Audio LED will turn off, indicated that Audio mode has been disengaged.

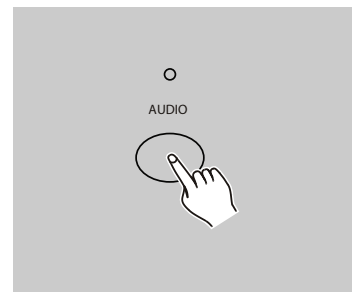

## 3.3 Running a Program with the Speed Slider.

1. Use built-in microphone, or plug the audio source into the RCA Audio Jack.
2. Select your program as described above.
3. Move the Speed slider to the SHOW MODE position (the bottom), then tap the Flash button (13-24) while pressing and holding down the Rec Speed button, the corresponding program will not run with the Standard beat any longer.

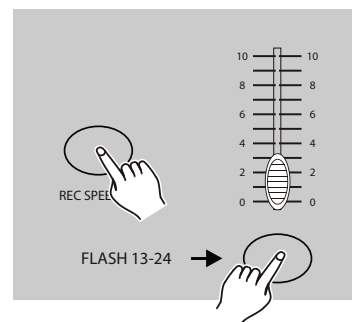

4. Now you may move the Speed Slider to select your desired speed.

**NOTE:** Step 3 is not necessary if the selected program is not recorded with the Standard Beat.

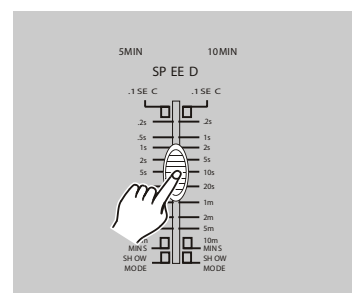

# OPERATION GUIDE

## 3.4 Running a Program with Standard Beat.

1. Disengage the Audio, then tap the Mode Select button to select CHNS SCENE mode.
2. Tap the Park button to select Mix Chase mode. The LED will illuminate to indicate your selection.
3. Select the program you would like to run.
4. Move the Speed slider until the Segment Display reads your desired value. Alternately, you can tap the Tap Sync button twice to define your beat time.
5. While pressing and holding down the Rec Speed button, tap the Flash button (13-24) that stores the program.
6. The program will then run with the set time or beat when engaged.
7. Repeat steps 4 and 5 to set a new beat time.

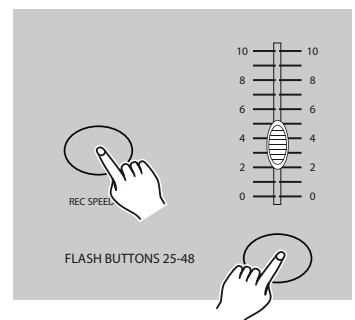
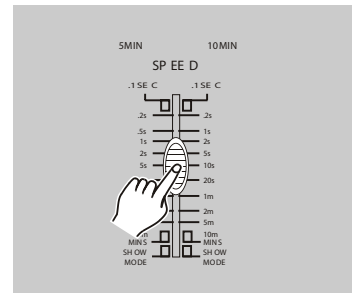
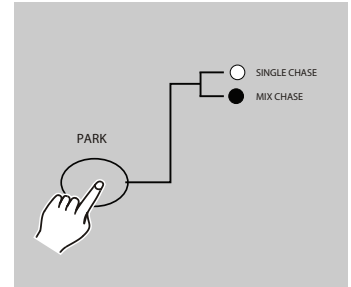

## 3.5 Change the Speed Mode Between 5 and 10 Minutes

1. Press and hold the Record button.
2. Tap Flash Button 5, or 10 three times (3x) while holding the Record button
3. The LED for 5MIN or 10MIN should illuminate to indicate that the speed slider has been set to the desired mode.

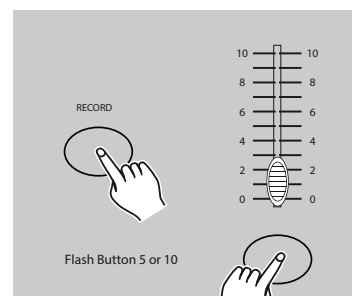
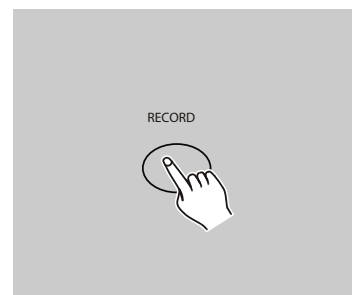

Tap this button  
three times

# MIDI OPERATION

## 1. SETTING MIDI IN

1. Tap the Flash button 1 three times while holding down the Record button. The segment display should read “CHI”, indicating that MIDI IN channel setup is available.

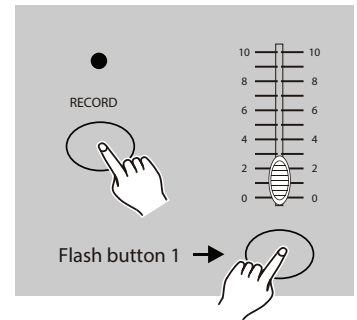

Tap this button three times

2. Tap the Flash button numbered from 1-16 to set a MIDI IN channel. The relevant channel LED will illuminate to indicate that the MIDI IN channel has been set.

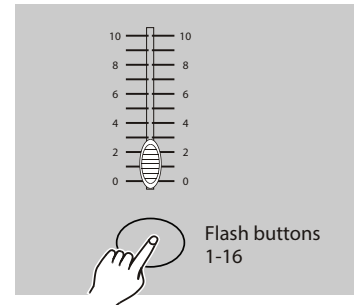

## 2. SETTING MIDI OUT

1. Tap the Flash button 2 three times while holding down the Record button. The segment display should read “CHO”, indicating that MIDI OUT channel setup is available.

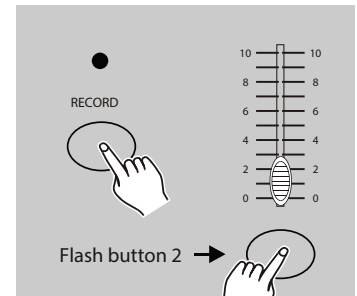

Tap this button three times

2. Tap the Flash button numbered from 1-16 to set a MIDI OUT channel. The relevant channel LED will illuminate to indicate that the MIDI OUT channel has been set.

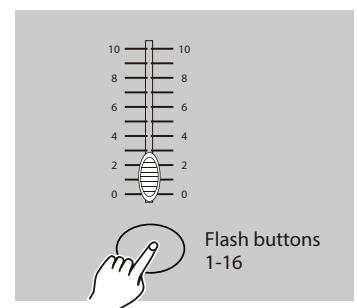

## 3. EXIT MIDI SETTING

Press and hold down the Record button. While holding down the Record button, tap the Rec Exit button to exit MIDI setting.

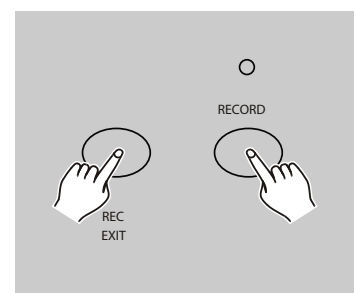

# MIDI OPERATION

## 4. RECEIVING MIDI FILE DUMP

Tap Flash button 3 three times while holding down the Record button. The Segment Display should read "IN" to indicate that the controller is ready to receive the MIDI file dump.

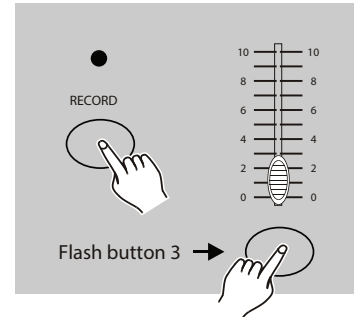

Tap this button three times

## 5. SENDING MIDI FILE DUMP

Tap Tap Flash button 4 three times while holding down the Record button. The Segment Display should read "OUT" to indicate that the controller is ready to send the file.

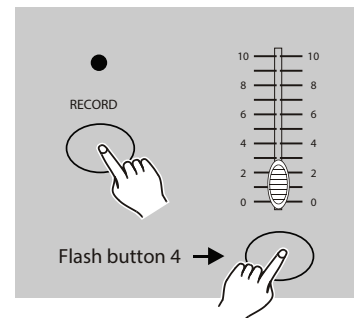

Tap this button three times

**NOTE:** During a file dump, all of the device's other functions will be disabled. Upon completion of the file dump, these functions will automatically be re-enabled. Additionally, the file dump will be interrupted and stop if an error or power failure occurs.

# MIDI OPERATION

## 6. IMPLEMENTATION

1. While receiving and sending MIDI data, all MIDI scenes and channels that are currently running will automatically paused if there is no response within 10 minutes.
2. While receiving and sending a file dump, the controller will automatically search for or send to Device ID of 55H(85), a file named DC2448 with an extension of "BIN(SPACE)".
3. File dump allows this controller to send its MIDI data to the next unit or to other MIDI devices.
4. There are two types of file dump mode: Open Loop Mode and Close Loop Mode. Both are deccribed in the following diagrams:

Open Loop Mode

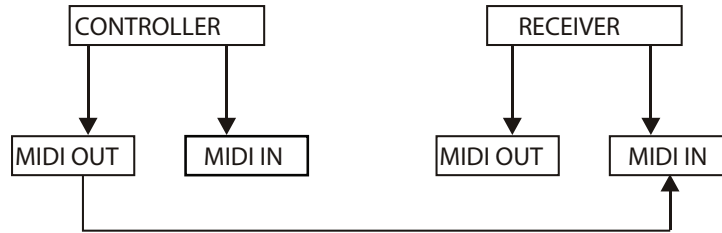

Close Loop Mode

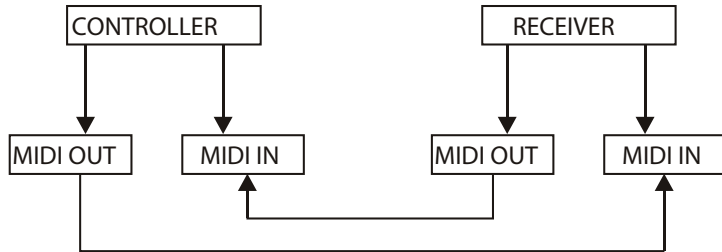

5. The controller will send and receive Note On and Note Off data via the Flash buttons, as detailed in the table below:

Note No.	Velocity	Function
22 - 69	Program Master	Turn on or off program 1-48
70 - 93	Channel Intensity	Active channel 1-24
94		Full On
95		Dark
96		Hold
97		Turn on or off Audio
98		CHNS SCENES
99		Double Preset Mode
100		Single Preset Mode
101		Step
102		Black Out

# DMX CHANNELS

## 1. DMX CHANNEL SETUP

### 1.1 Add/Assign DMX Channel.

1. Hold the Record button and press the Flash 8 button 3 times. This will access the DMX channel setup. The display screen will show the current channel.
2. Use the Up and Down buttons to scroll to the desired DMX channel (1 to 512).
3. Press the desired Flash button (1 to 24) to assign the DMX channel to a console channel. The LED on that console channel will illuminate to indicate that it has been selected.
4. Multiple DMX channels can be assigned to the same console channel, by repeating steps 2 and 3 for each additional channel. Please note that all DMX channels assigned to the same console channel will respond in unison.
5. Hold the Record button and press Exit to leave this setup mode.

### 1.2 Remove DMX Channel.

1. Use the Up and Down buttons to scroll to the DMX channel you wish to remove.
2. Press the Blackout button. The channel should now be removed.

### 1.3 Assign All Console Channels to a Single DMX Channel.

1. Use the Up and Down buttons to scroll to a desired DMX channel.
2. Press the Full On button. All console channels are now tied to a single DMX channel.

## 2. CLEAR DMX CHANNEL SETUP

1. Make sure the device is in Record mode. Press and hold the Record button.

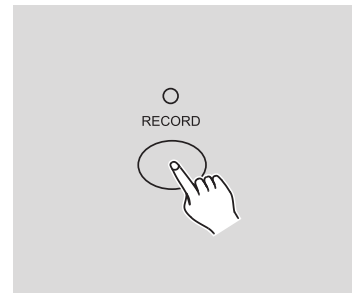

2. Tap the Flash 7 button 3 times while holding down the Record button. This allows the user to clear the DMX channel setup and reset the DMX channels to the default factory setting (1-24 channel sequence).

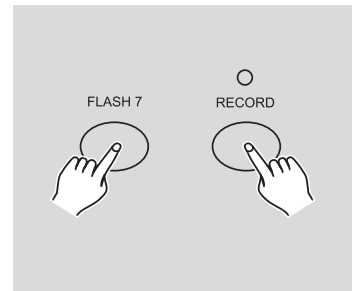

## 3. CALL 12 PRE-SET PROGRAMS

1. Make sure the device is in Record mode. Press and hold the Record button.
2. Tap Flash 6, 6, 8, and 8 buttons in sequence while holding the Record button. This allows the user to call up the 12 factory default programs in page 1. Note that all other programs will be cleared.

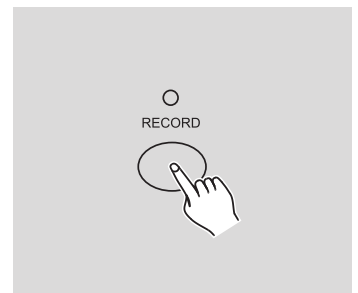

# BRIEF OF MAIN FUNCTIONS

## **Reverse the direction of the scene.**

1. Press the ALL REV Button to make all the scenes change their directions.
2. To reverse the chasing direction of all the programs with speed control, press the Chase Rev Button.
3. To reverse the chasing direction of all the programs with standard beat, press the Beat Rev Button.
4. Reverse chasing direction of any program by pressing and holding the Rec One Button, then pressing down the Flash Button corresponding to your desired program. Release together.

## **Fade Time.**

1. Adjust the amount of time it will take for the dimmer to go from zero output to maximum output and vice versa.
2. This setting is adjusted using the Fade Time Slider, which varies from instant to 10 minutes.

## **Tap Sync Button.**

1. The Tap Sync button is used to set and synchronize the chase rate (the rate at which all scenes will sequence) by tapping the button several times. The chase rate will synchronize to the time of the last two taps. The LED above the Step Button will flash at the new chase rate. The chase rate may be set anytime, whether or not a program is running.
2. Tap Sync will override any previous setting of the speed slider control until the slider is moved again.
3. Use of Tap Sync in setting a standard beat is the same with speed control slider

## **Master Slider.**

- Master Slider control provides proportional level control over all channels and scenes with the exception of the Flash Buttons. For example, whenever the Master slider control is at minimum, all stage outputs will be at zero except for any resulting from a Flash Button or FULL ON Button. If the Master is at 50%, all outputs will be at only 50% of the setting of current channel or scenes, except for any resulting from a Flash Button or FULL ON Button.
- If the Master is at full, all outputs will follow the unit setting.
- Master A always controls outputs of channels.
- Master B controls the program or a scene, except in Double Preset Mode.

## **Single Mode.**

1. All programs will run in sequential order of program number.
2. The Segment Display will show the running program number.
3. All programs will be controlled by the same Speed Slider.
4. Press the MODE SELECT BUTTON and select "CHNS SCENES".
5. Press the PARK BUTTON to select SINGLE CHASE MODE. A red LED will illuminate to indicate the selection.

## **Mix Mode.**

1. All programs run synchronously.
2. All programs can be controlled by the same SLIDER SPEED, or the speed of each program may be controlled individually. (See Speed Setting ).
3. Press the MODE SELECT BUTTON and select "CHNS SCENES".
4. Press the PARK BUTTON to select MIX CHASE MODE. A yellow LED will illuminate to indicate this selection.

# BRIEF OF MAIN FUNCTIONS

## **Dimmer Display.**

1. The 3-Digit Segment Display is used to display intensity percentage or absolute DMX value.
2. To change between percentage and absolute value, press and hold the Shift Button. Then while continuing to hold down the Shift button, press the % or 0-255 Button to switch between percentage and absolute values.
3. For example, if the Segment Display reads “076”, it means a percentage value 76%. If the Segment Display reads “076.”, it means the DMX value 76.

## **Blind and Home.**

1. The blind function temporarily removed channels from a chase while the chase is running, and gives the user manual control over the channel.
2. Press and hold the Blind Button and tap the relative Flash Button you want to temporarily remove the channel from the chase.
3. To return to normal chase again, press and hold the Home Button and push the Flash Button.

## **Park.**

- In CHNS SCENES Mode, press the Park button changes the chasing mode of programs between Single Mode and Mix Mode.
- In Double Preset Mode, pressing the Park button creates the same effect as pushing Master Slider B to the top.
- In Single Preset Mode, this button could temporarily records the current output. Master Slider B can then be used to make adjustments.

## **Add and Kill.**

- The ADD/KILL Button changes the mode of the flash buttons. Normally, the flash buttons are in Add mode, and pressing any flash button will not kill other scenes, allowing multiple scenes to be on at a time.
- The Kill mode is activated by pressing the ADD/KILL button. The LED above this button will illuminate to indicate the device is in Kill mode. Pressing any flash button will now kill other active scenes or programs.
- In Kill Mode, the killed program continues to run but simply produces no output.

## **Double Preset**

- Press Mode Select Button to enter Double Preset Mode.
- In this mode, Channel Sliders 1-12 and channel sliders 25-48 both control Channel 1-24.
- Master A controls channel Slider 1-12, while Master B controls Channel Sliders 13-24.
- In this Mode, no scene can be recorded.

## **Example:**

1. Enter the Double Preset Mode.
2. Push Channel Sliders 1 to 6 to the top and move Channel Sliders 19 to 24 to the maximum.
3. Move Master A and B to the same level and push them to the same direction. This will trigger a scene.

# QUICK REFERENCE GUIDE

CATEGORY	FUNCTION	OPERATION METHOD
Recording	Record Enable	Hold "RECORD" and key in record code on Prest A & B
	Erase All Programs	Hold "RECORD" and key in "1-4-2-3" on Preset A
	Record Disable	Hold "RECORD" and press "EXIT"
	Clear Memory	Hold "RECORD" and press "REC CLEAR"
	Record Step	Set Scene, then hold "RECORD"
	Record Chase	Set Scene, then press "RECORD". Repeat for each step in the chase.
	Assign to Fader	Hold "RECORD" and press "SCENE"
	Record Chase Speed	Set Speed Fader at "Show", then hold "REC SPEED" and press "SCENE"
	Edit Channel Levels	Turn on Edit Mode, then hold "UP" or "DOWN" and press "CHANNEL"
	Add Step	<ol style="list-style-type: none"> <li>1. Turn on Edit Mode</li> <li>2. Record New Step</li> <li>3. Select step by pressing "STEP" to scroll through the steps in order until you reach the location where you want to insert the new step</li> <li>4. Press "INSERT"</li> </ol>
	Delete Step	<ol style="list-style-type: none"> <li>1. Turn on Edit Mode</li> <li>2. Press "STEP" to scroll through the steps in order until you find the step you wish to delete</li> <li>3. Press "DELETE"</li> </ol>
	Quit Exit	Hold "RECORD" and press "EXIT"
	Factory Record Code	Hold "RECORD" and then press "1-6-6-8"
Play Back	Preset Mode	Press "MODE SELECT"
	Double Preset	Set Scene, Master A&B Up/Down
	Single Preset Park	Set Scene, press "PARK", move Masters down
	Flash Add/Kill	Press "ADD/KILL" (Off = ADD, On = KILL)
	Manual Scene	Fade at Instant, Scene Up/Down
	Fade Scene	Set Fade time, Scene Up/Down
	Select Chase	Chase Fader up
	Manual Chase	Speed at Show, press "STEP" to chase through scenes
	Fade Chase	Select Chase, Set Speed, Fade
	Audio Chase	Press "AUDIO": On = AUDIO, Off = CHASE
	Blind Channel	Hold "BLIND" and press "CHANNEL"
	Home Channel	Hold "HOME" and press "CHANNEL"
	Hold Scene	Press "HOLD"
	Dead Blackout	Press "DARK"
	Display % or 0-255	Hold "RECORD" and press "% OR 0-255"
	Call Pre-Set Program	Hold "RECORD" and press "FLASH-6, FLASH-6, FLASH-8, FLASH-8"

# QUICK REFERENCE GUIDE

CATEGORY	FUNCTION	OPERATION METHOD
Setup	MIDI In Ch. Setup	Hold "RECORD" and press "FLASH1, FLASH1, FLASH1"
	MIDI Out Ch. Setup	Hold "RECORD" and press "FLASH2, FLASH2, FLASH2"
	MIDI Exclusive Input	Hold "RECORD" and press "FLASH3, FLASH3, FLASH3"
	MIDI Exclusive Output	Hold "RECORD" and press "FLASH4, FLASH4, FLASH4"
	Max Speed Setup, 5 minutes	Hold "RECORD" and press "FLASH5, FLASH5, FLASH5"
	Max Speed Setup, 10 minutes	Hold "RECORD" and press "FLASH10, FLASH10, FLASH10"
	Quit MIDI In Ch. Setup	Hold "RECORD" and press "EXIT"
	Quit MIDI Out Ch. Setup	Hold "RECORD" and press "EXIT"
	DMX Ch. Assignment	1. Hold "RECORD" and press "FLASH8, FLASH8, FLASH8" 2. Press "UP" or "DOWN" for DMX channel
	DMX Ch. Reset	Hold "RECORD" and press "FLASH7, FLASH7, FLASH7"
Change Record Code	Change Record Code	<ol style="list-style-type: none"> <li>1. Record enable: Hold "RECORD" button, then press "FLASH1, FLASH6, FLASH6, FLASH8"</li> <li>2. Hold "RECORD" and "EDIT" then enter a new 4-digit record code using the Flash buttons</li> <li>3. Enter the new record code a second time to confirm</li> <li>4. To cancel the new code, hold "RECORD" and "EXIT"</li> </ol>

# USB STICK

## SAVING FILE TO USB STICK

**Note: USB Stick cannot exceed 32GB and must be blank.**

To save a memory file to a USB stick, please follow these steps:

1. Format the USB stick for FAT 16 or FAT 32.
2. Press and hold the “SHIFT” button, then press the “UP” button. The LED display will show “Sav”.
3. Release the “SHIFT” and “UP” button.
4. Press a flash button (1 to 24 for Scene Setter) to select the desired flash button number for the file name. For example, if button 1 is pressed, the file name that will be created is “FILE1.PRO” (do not change the file names).
5. The selected flash button LED should turn on solid, indicating that the memory file is being stored to the USB. The LED display will show “Fxx” (xx represents the flash button that was selected).
6. When the memory file is finished saving, the LED display will show “END”.

## LOADING FILE FROM USB STICK

To load a memory file from a USB stick, please follow these steps:

1. Press and hold the “SHIFT” button, then press the “DOWN” button. The LED display will show “Lod”.
2. Release the “SHIFT” and “DOWN” button.
3. Press the flash button associated with the memory file that you want to load. The LED display will show “Fxx” (xx represents the flash button that was selected).
4. The controller will start loading the data from the USB.
5. When the memory file is finished loading, the LED display will show “END”.

**Note:** the USB port is located on the rear of the Scene Setter with the connections as seen below.



## SOFTWARE UPDATE

A USB stick can be used to update the fixture to the latest software. Contact ADJ Support for latest software version:

**ADJ SERVICE USA - Monday - Friday 8:00am to 4:30pm PST**  
Voice: 800-322-6337 | Fax: 323-582-2941 | support@adj.com

**ADJ SERVICE EUROPE - Monday - Friday 08:30 to 17:00 CET**  
Voice: +31 45 546 85 60 | Fax: +31 45 546 85 96 | support@adj.eu

# SPECIFICATIONS

- 24 channel conventional dimming console
- Two scene operation (A/B faders)
- 11,000 programmable scenes- password protected
- 48 programmable chases (stacks)- password protected
- Up to 1,000 scenes (steps) per chase
- 12 x 4 Pages = 48 total chases
- Solo & Pile On chase operation
- Blind & Dark functions
- 24 individual channel faders
- 24 bump buttons
- Tap Sync button for chase speed / fade override
- Independent speed & fade control
- Full-On button for 100% momentary output to all 24 channels
- Bright LCD display
- Use in conjunction with the ADJ or Elation: DP-DMX20L, CYBER PAK, UNI PAK-II, UNI BAR, DP-415, DP-640, RMD620 & RMD1210
- Line level audio input and built in microphone for music sync operation
- Audio level fader
- Fog Machine input and trigger button- compatible with ADJ Vaporizer, MB-1000, Stallion, Vapor-Flow, Fog Storm-1200 & 1700
- DMX Polarity switch (2-, 3+, / 2+, 3-)
- Midi In, Out & Thru connectors
- Power: 120V / 12V DC, 500mA. (Included) \*Also available in 220V
- Dimensions: 13"L x 21"W x 5"H (330mm x 533mm x 127mm)
- Weight: 10 lbs. (4.5kg)

