



# JOLT PANEL FX2

User Manual

©2024 ADJ Products, LLC all rights reserved. Information, specifications, diagrams, images, and instructions herein are subject to change without notice. ADJ Products, LLC logo and identifying product names and numbers herein are trademarks of ADJ Products, LLC. Copyright protection claimed includes all forms and matters of copyrightable materials and information now allowed by statutory or judicial law or hereinafter granted. Product names used in this document may be trademarks or registered trademarks of their respective companies and are hereby acknowledged. All non-ADJ Products, LLC brands and product names are trademarks or registered trademarks of their respective companies.

**ADJ Products, LLC** and all affiliated companies hereby disclaim any and all liabilities for property, equipment, building, and electrical damages, injuries to any persons, and direct or indirect economic loss associated with the use or reliance of any information contained within this document, and/or as a result of the improper, unsafe, insufficient and negligent assembly, installation, rigging, and operation of this product.

**ADJ PRODUCTS LLC World Headquarters**

6122 S. Eastern Ave. | Los Angeles, CA 90040 USA

Tel: 800-322-6337 | Fax: 323-582-2941 | [www.adj.com](http://www.adj.com) | [lsupport@adj.com](mailto:lsupport@adj.com)

**ADJ Supply Europe B.V.**

Junostraat 2 | 6468 EW Kerkrade | Netherlands

Tel: +31 45 546 85 00 | Fax: +31 45 546 85 99 | [www.adj.eu](http://www.adj.eu) | [support@adj.eu](mailto:support@adj.eu)

**Europe Energy Saving Notice**

Energy Saving Matters (EuP 2009/125/EC)

Saving electric energy is a key to help protecting the environment. Please turn off all electrical products when they are not in use. To avoid power consumption in idle mode, disconnect all electrical equipment from power when not in use. Thank you!

**DOCUMENT VERSION**



Due to additional product features and/or enhancements, an updated version of this document may be available online.

Please check [www.adj.com](http://www.adj.com) for the latest revision/update of this manual before beginning installation and/or programming.

Date	Document Version	Software Version	DMX Channels	Notes
01/12/2024	1.0	1.0	6/9/13/16/18/36/41/51/81/126/141	Initial Release
12/09/2024	1.1	1.03	6/9/13/18/20/36/41/43/51/81/83/126/141/143	Updated System Menu, DMX Set Up, DMX Traits, Pixel Zones, Specifications

# CONTENTS

<b>General Information</b>	<b>4</b>
<b>Limited Warranty (USA Only)</b>	<b>5</b>
<b>Warranty Registration   Features</b>	<b>6</b>
<b>Safety Guidelines</b>	<b>7</b>
<b>Overview</b>	<b>8</b>
<b>Lens Installation</b>	<b>9</b>
<b>Installation Guidelines</b>	<b>10</b>
<b>Fan Modes and Low Noise Operation</b>	<b>15</b>
<b>System Menu</b>	<b>16</b>
<b>Dimmer Modes and Curves</b>	<b>19</b>
<b>DMX Setup</b>	<b>20</b>
<b>DMX Traits</b>	<b>22</b>
<b>Remote Device Management (RDM)</b>	<b>27</b>
<b>Error Codes</b>	<b>28</b>
<b>LED Pixel Zones</b>	<b>29</b>
<b>Daisy Chain Power Linking   Cleaning and Maintenance</b>	<b>31</b>
<b>Specifications</b>	<b>32</b>
<b>Dimensions</b>	<b>33</b>

# GENERAL INFORMATION

## INTRODUCTION

Please read and understand the instructions in this manual carefully and thoroughly before attempting to operate this device. These instructions contain important safety and use information.

**This product is intended for use by professionally trained personnel only, and is not suitable for private use.**

## Unpacking

Every device has been thoroughly tested and has been shipped in perfect operating condition. Carefully check the shipping carton for damage that may have occurred during shipping. If the carton is damaged, carefully inspect the device for damage, and be sure all accessories necessary to install and operate the device have arrived intact. In the event damage has been found or parts are missing, please contact our customer support team for further instructions. Please do not return this device to your dealer without first contacting customer support. Please do not discard the shipping carton in the trash. Please recycle whenever possible.

**FOR SOFTWARE UPDATES, CONTACT ADJ CUSTOMER SUPPORT.**

## CUSTOMER SUPPORT

Contact ADJ Service for any product related service and support needs. Also visit [forums.adj.com](https://forums.adj.com) with questions, comments or suggestions.

**ADJ SERVICE USA** - Monday - Friday 8:00am to 4:30pm PST  
323-582-2650 | Fax: 323-832-2941 | [support@adj.com](mailto:support@adj.com)

**ADJ SERVICE EUROPE** - Monday - Friday 08:30 to 17:00 CET  
+31 45 546 85 60 | Fax: +31 45 546 85 96 | [support@adj.eu](mailto:support@adj.eu)

**REPLACEMENT PARTS** please visit [parts.adj.com](https://parts.adj.com)



## IMPORTANT NOTICE!

**THERE ARE NO USER SERVICEABLE PARTS INSIDE THIS UNIT. DO NOT ATTEMPT ANY REPAIRS YOURSELF; DOING SO WILL VOID YOUR MANUFACTURER'S WARRANTY. DAMAGES RESULTING FROM MODIFICATIONS TO THIS FIXTURE AND/OR THE DISREGARD OF SAFETY INSTRUCTIONS AND GUIDELINES IN THIS MANUAL VOID THE MANUFACTURER'S WARRANTY AND ARE NOT SUBJECT TO WARRANTY CLAIMS AND/OR REPAIRS.**

# LIMITED WARRANTY (USA ONLY)

- A. ADJ Products, LLC hereby warrants, to the original purchaser, ADJ Products, LLC products to be free of manufacturing defects in material and workmanship for a prescribed period from the date of purchase (see specific warranty period on reverse). This warranty shall be valid only if the product is purchased within the United States of America, including possessions and territories. It is the owner's responsibility to establish the date and place of purchase by acceptable evidence, at the time service is sought.
- B. For warranty service, you must obtain a Return Authorization number (RA#) before sending back the product-please contact ADJ Products, LLC Service Department at 800-322-6337. Send the product only to the ADJ Products, LLC factory. All shipping charges must be pre-paid. If the requested repairs or service (including parts replacement) are within the terms of this warranty, ADJ Products, LLC will pay return shipping charges only to a designated point within the United States. If the entire instrument is sent, it must be shipped in its original package. No accessories should be shipped with the product. If any accessories are shipped with the product, ADJ Products, LLC shall have no liability whatsoever for loss of or damage to any such accessories, or for the safe return thereof.
- C. This warranty is void if the serial number has been altered or removed; if the product is modified in any manner which ADJ Products, LLC concludes, after inspection, affects the reliability of the product, if the product has been repaired or service by anyone other than ADJ Products, LLC factory unless prior written authorization was issued to purchaser by ADJ Products, LLC; if the product is damaged because not properly maintained as set forth in the instruction manual.
- D. This is not a service contract, and this warranty does not include maintenance, cleaning or periodic check up. During the period specified above, ADJ Products, LLC will replace defective parts at its expense with new or refurbished parts, and will absorb all expenses for warranty service and repair labor by reason of defects in material or workmanship. The sole responsibility of ADJ Products, LLC under this warranty shall be limited to the repair of the product, or replacement thereof, including parts, at the sole discretion of ADJ Products, LLC. All products covered by this warranty were manufactured after August 15, 2012, and bear identifying marks to that effect.
- E. ADJ Products, LLC reserves the right to make changes in design and/or improvements upon its products without any obligation to include these changes in any products theretofore manufactured.
- F. No warranty, whether expressed or implied, is given or made with respect to any accessory supplied with products described above. Except to the extent prohibited by applicable law, all implied warranties made by ADJ Products, LLC in connection with this product, including warranties of merchantability or fitness, are limited in duration to the warranty period set forth above. And no warranties, whether expressed or implied, including warranties of merchantability or fitness, shall apply to this product after said period has expired. The consumer's and/or Dealer's sole remedy shall be such repair or replacement as is expressly provided above; and under no circumstances shall ADJ Products, LLC be liable for any loss or damage, direct or consequential, arising out of the use of, or inability to use, this product.
- G. This warranty is the only written warranty applicable to ADJ Products, LLC Products and supersedes all prior warranties and written descriptions of warranty terms and conditions heretofore published.

## LIMITED WARRANTY PERIODS

- **Non L.E.D. Lighting Products = 1-year (365 days) Limited Warranty** (Such as: Special Effect Lighting, Intelligent Lighting, UV lighting, Strobes, Fog Machines, Bubble Machines, Mirror Balls, Par Cans, Trussing, Lighting Stands etc. excluding LED and lamps)
- **Laser Products = 1 Year (365 Days) Limited Warranty** (excludes laser diodes which have 6 month limited warranty)
- **L.E.D. Products = 2-year (730 days) Limited Warranty** (excluding batteries which have a 180 day limited warranty)  
Note: 2 Year Warranty only applies to purchases within the United States.
- **StarTec Series = 1 Year Limited Warranty** (excluding batteries which have a 180 day limited warranty)
- **ADJ DMX Controllers = 2 Year (730 Days) Limited Warranty**

# WARRANTY REGISTRATION

The Jolt Panel FX2 carries a 2 year limited warranty. Please fill out the enclosed warranty card to validate your purchase. All returned service items, whether under warranty or not, must be freight pre-paid and accompanied by a return authorization (R.A.) number. The R.A. number must be clearly written on the outside of the return package. A brief description of the problem as well as the R.A. number must also be written down on a piece of paper included in the shipping carton. If the unit is under warranty, you must provide a copy of your proof of purchase invoice. You may obtain an R.A. number by contacting our customer support team on our customer support number. All packages returned to the service department not displaying an R.A. number on the outside of the package will be returned to the shipper.

## FEATURES

The ADJ Jolt Panel FX2 features a central strip of 112 x 5-Watt cool white SMD LEDs, surrounded on both sides by a total of 448 x .5-Watt RGB color mixing SMD LEDs. This allows the same fixture to generate intense white strobing as well as colored washes and strobe effects. Both types of LED are grouped into independently controllable zones (16 white and 32 color), which means the unit can also be used to generate strobe chases and other 'eye candy' effects.

- 40 x RGB LED zones
- 6 x Cool White LED zones
- 25 built-in RGB LED Program Macros
- 9 built-in Cool White LED Program Macros

### INCLUDED ITEMS:

- 1x 6ft (1.83m) Indoor Power locking to Edison power cable (U.S.)
- 1x Frost Filter

### OPTIONAL ITEMS:

- 180mm Omega Bracket
- JPFXBLKF (Black Filter)
- JPFXLINF (Linear Effect Filter)

### IP RATING

This device is IP20 rated. This means that the unit is protected against the intrusions of solids approximately the size of an adult finger (2.5mm) or larger, but **the unit is not protected against water or liquid intrusion of any kind.**

# SAFETY GUIDELINES

**THIS FIXTURE IS COMPOSED OF SOPHISTICATED ELECTRONIC COMPONENTS. TO GUARANTEE SMOOTH OPERATION, IT IS IMPORTANT TO FOLLOW ALL INSTRUCTIONS AND GUIDELINES IN THIS MANUAL. ADJ PRODUCTS, LLC IS NOT RESPONSIBLE FOR INJURY AND/OR DAMAGES RESULTING FROM THE MISUSE OF THIS FIXTURE DUE TO THE DISREGARD OF THE INFORMATION PRINTED IN THIS MANUAL. ONLY QUALIFIED AND/OR CERTIFIED PERSONNEL SHOULD PERFORM INSTALLATION OF THIS FIXTURE AND ONLY THE ORIGINAL RIGGING PARTS INCLUDED WITH THIS FIXTURE SHOULD BE USED FOR INSTALLATION. ANY MODIFICATIONS TO THE FIXTURE AND/OR THE INCLUDED MOUNTING HARDWARE WILL VOID THE ORIGINAL MANUFACTURER'S WARRANTY AND INCREASE THE RISK OF DAMAGE AND/OR PERSONAL INJURY. ONLY CERTIFIED PERSONNEL SHOULD PERFORM INSTALLATION OF THIS FIXTURE.**

- PROTECTION CLASS 1 - FIXTURE MUST BE PROPERLY GROUNDED.
- THERE ARE NO USER SERVICEABLE PARTS INSIDE THIS UNIT.
- DO NOT ATTEMPT ANY REPAIRS YOURSELF; DOING SO WILL VOID YOUR MANUFACTURER'S WARRANTY. DAMAGES RESULTING FROM MODIFICATIONS TO THIS FIXTURE AND/OR THE DISREGARD OF SAFETY INSTRUCTIONS AND GUIDELINES IN THIS MANUAL VOID THE MANUFACTURER'S WARRANTY AND ARE NOT SUBJECT TO ANY WARRANTY CLAIMS AND/OR REPAIRS.
- DO NOT PLUG FIXTURE INTO A DIMMER PACK!
- NEVER OPEN THIS FIXTURE WHILE IN USE!
- UNPLUG POWER BEFORE SERVICING FIXTURE!
- NEVER TOUCH FIXTURE DURING OPERATION, AS IT MAY BE HOT!
- KEEP FLAMMABLE MATERIALS AWAY FROM FIXTURE!
- NEVER LOOK DIRECTLY INTO THE LIGHT SOURCE!
- RETINA INJURY RISK - MAY INDUCE BLINDNESS!
- SENSITIVE PERSONS MAY SUFFER AN EPILEPTIC SHOCK!
- INDOOR / DRY LOCATIONS USE ONLY!
- DO NOT EXPOSE FIXTURE TO RAIN AND MOISTURE!
- MINIMUM DISTANCE TO OBJECTS/SURFACES IS 6.6 FEET (2 METERS)
- MINIMUM DISTANCE TO FLAMMABLE MATERIALS FROM THE SURFACE IS 1.6 FEET (0.5 METER).
- DO NOT TOUCH the fixture housing during operation. Turn OFF the power and allow approximately 60 minutes for the fixture to cool down before serving.
- DO NOT shake fixture, and avoid brute force when installing and/or operating fixture.
- DO NOT operate fixture if the power cord is frayed, crimped, damaged and/or if any of the power cord connectors are damaged and do not insert into the fixture securely with ease. NEVER force a power cord connector into the fixture. If the power cord or any of its connectors are damaged, replace it immediately with a new one of the same power rating.
- DO NOT block any air ventilation slots. All fan and air inlets must remain clean and never blocked. Allow approx. 6" (15cm) between fixture and other devices or a wall for proper cooling.
- When installing fixture in a suspended environment, always use mounting hardware that is no less than M10 x 25 mm, and always install fixture with an appropriately rated safety cable.
- Always disconnect fixture from main power source before performing any type of service and/or cleaning procedure.
- Only handle the power cord by the plug end. Never pull out the plug by tugging the wire portion of the cord.
- During the initial operation of this fixture, a light smoke or smell may emit from the interior of the fixture. This is a normal process and is caused by excess paint in the interior of the casing burning off from the heat associated with the lamp and will decrease gradually over time.
- Consistent operational breaks will ensure fixture will function properly for many years.
- Only use original packaging and materials to transport the fixture in for service.

# OVERVIEW

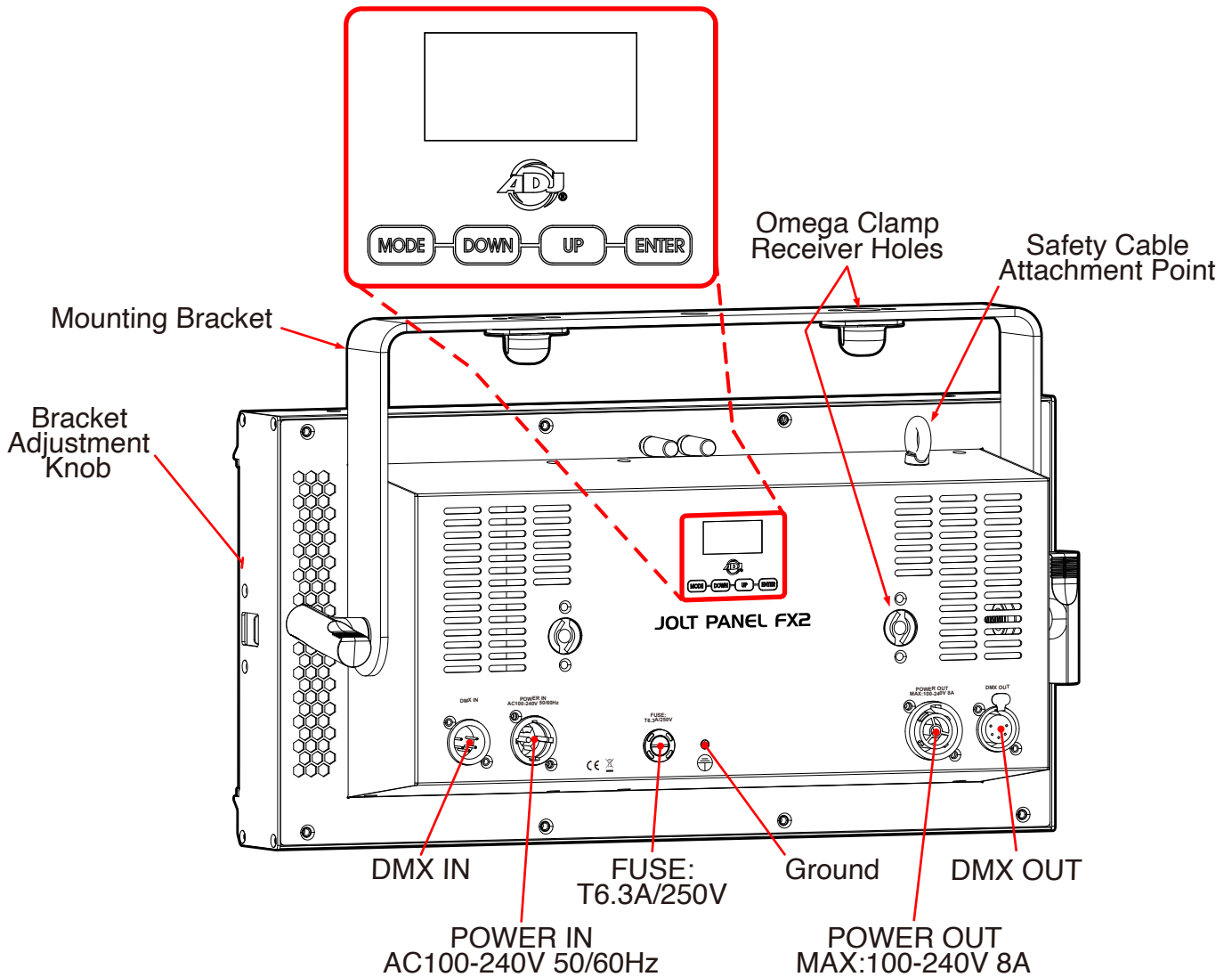
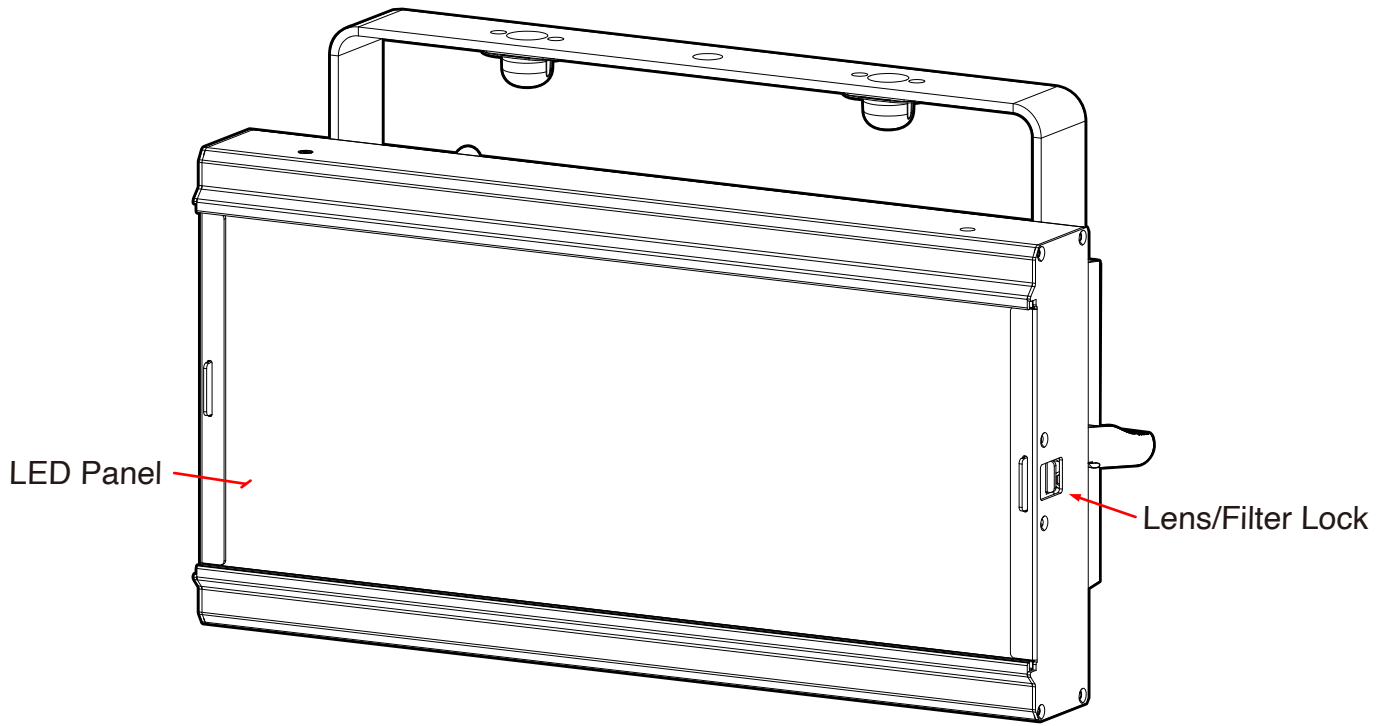

# LENS INSTALLATION

Locate Frost Filter Lens Lock and press down to unlock it. Carefully slide Frost Filter Lens into the Lens Slots. Once in place, secure the Frost Filter Lens by pressing upwards to relock it.

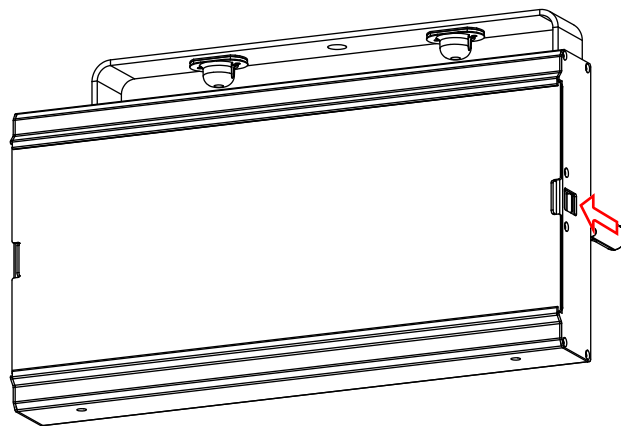
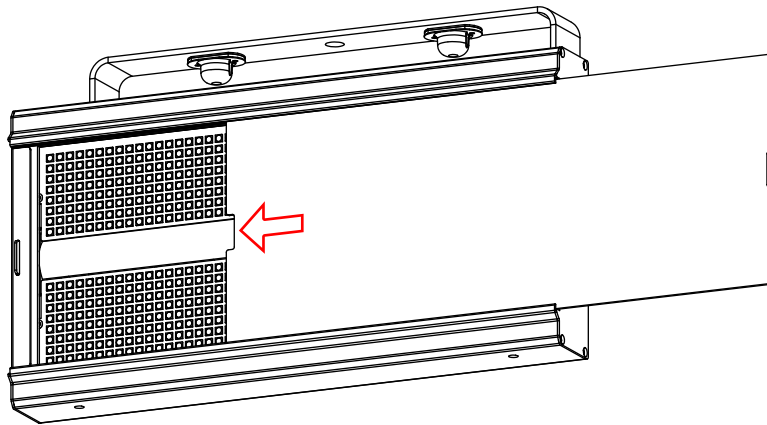
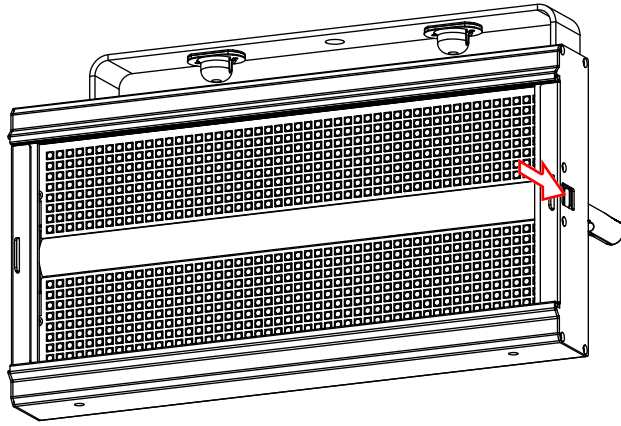

# INSTALLATION GUIDELINES



## **FLAMMABLE MATERIAL WARNING**

Keep fixture minimum 5.0 feet (1.5m) away from flammable materials and/or pyrotechnics.



## **ELECTRICAL CONNECTIONS**

A qualified electrician should be used for all electrical connections and/or installations.



## **MINIMUM DISTANCE TO OBJECTS/SURFACES IS 6.6 FEET (2 METERS).**

**MINIMUM DISTANCE OF INFLAMMABLE MATERIALS FROM THE SURFACE IS 1.6 FEET (0.5 METERS).**

## **DO NOT INSTALL THE FIXTURE IF YOU ARE NOT QUALIFIED TO DO SO!**

- Fixture **MUST** be installed following all local, national, and country commercial electrical and construction codes and regulations.
- Before rigging/mounting a single fixture or multiple fixtures to any metal truss/structure or placing the fixture(s) on any surface, a professional equipment installer **MUST** be consulted to determine if the metal truss/structure or surface is properly certified to safely hold the combined weight of the fixture(s), clamps, cables, and accessories.
- Maximum ambient operating temperature is **113°F (45°C)**. Do not use fixture when ambient temperature exceeds this value.
- Fixture(s) should be installed outside walking paths, seating areas, or areas where unauthorized personnel might reach the fixture by hand.
- **NEVER** stand directly below the fixture(s) when rigging, removing, or servicing.
- Overhead fixture installation must always be secured with a secondary safety attachment, such as an appropriately rated safety cable.
- Allow approximately 60 minutes for the fixture to cool down before servicing.

## **IP RATING**

**This device is IP20 rated. This means that the unit is protected against the intrusion of solids 2.5mm in size or larger (approximately the size of an adult finger tip). The unit is NOT protected against water or liquid intrusion of any kind!**

## **RIGGING**

**Overhead rigging requires extensive experience, including calculating working load limits, knowledge of installation material being used, and periodic safety inspection of all installation material and the fixture, among other skills. If you lack these qualifications, do not attempt the installation yourself. Improper installation can result in bodily injury.**

# INSTALLATION GUIDELINES

## CLAMP INSTALLATION

This fixture features an adjustable bracket for the attachment of a Mounting Clamp (not included). There is also a safety cable attachment point on the rear of the fixture. When mounting the fixture to a truss or any other suspended or overhead installation, be sure to secure appropriately rated clamp (not included) to the yoke, and attach a separate SAFETY CABLE of the appropriate weight rating to the safety cable attachment point.

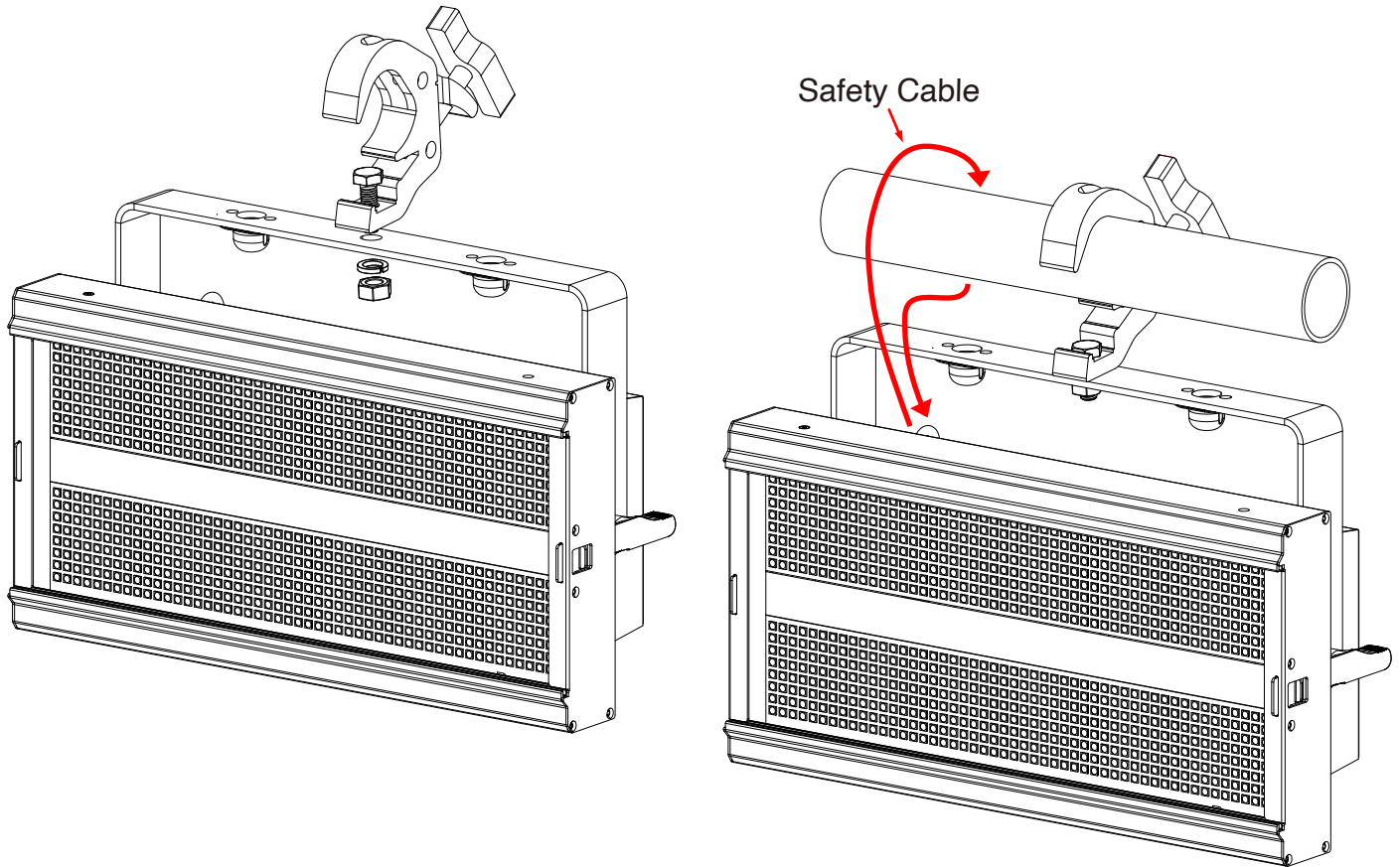

## SAFETY CABLE:



**ALWAYS ATTACH A SAFETY CABLE WHENEVER INSTALLING THIS FIXTURE IN A SUSPENDED ENVIRONMENT TO ENSURE THAT THE FIXTURE WILL NOT FALL IF THE CLAMPS FAIL.**

# INSTALLATION GUIDELINES

## OMEGA BRACKETS INSTALLATION

Secure the Mounting Clamp (not included) to the Omega Bracket (not included), then insert the Omega Bracket Assembly into the matching holes on either the Mounting Bracket, or the rear panel of the Fixture. Secure the Omega Bracket by turning each quick-lock fastener ¼ turn clockwise; making sure the fastener is completely locked.

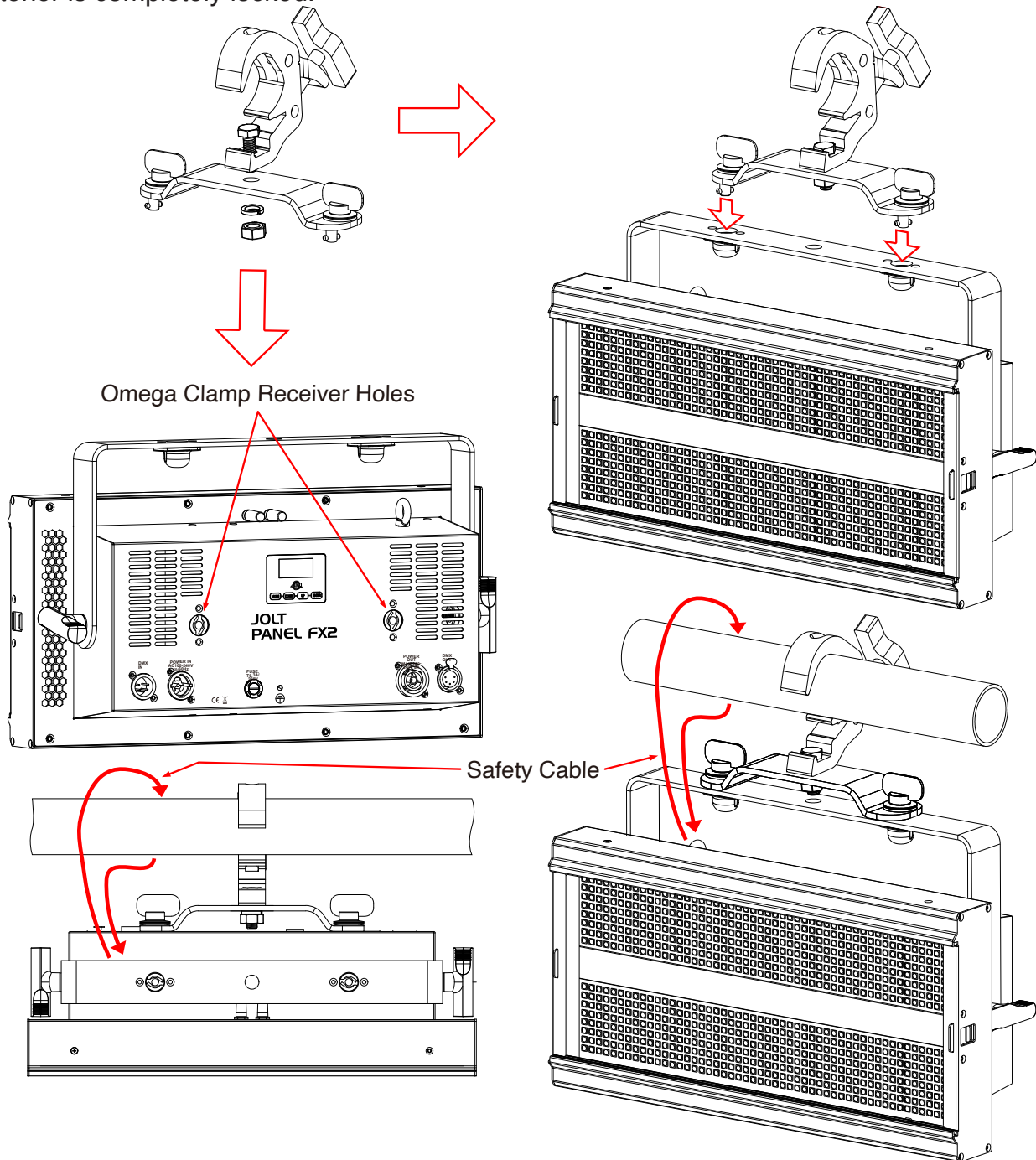

## SAFETY CABLE

**ALWAYS ATTACH A SAFETY WHENEVER INSTALLING THIS FIXTURE IN A SUSPENDED ENVIRONMENT TO ENSURE THE FIXTURE WILL NOT FALL IF THE CLAMP FAILS.**  
**CLAMP INSTALLATION**

When mounting fixture to truss, be sure to secure an appropriately rated professional grade rigging clamp to the included **Omega Brackets** using an M10 screw fitted through the center hole of the **Omega Brackets**. The fixture provides built-in rigging points for a **SAFETY CABLE** (not included). Be sure to only use one of the designated rigging points for the safety cable and never secure a safety cable to a carrying handle.

# INSTALLATION GUIDELINES

## RIGGING

Overhead rigging requires extensive experience, including among others, calculating working load limits, installation material being used, and periodic safety inspection of all installation material and the fixture. If you lack these qualifications, do not attempt the installation yourself. Improper installation can result in bodily injury.

This fixture is designed to be mounted vertically (hanging or upright), or horizontally (perpendicular to vertical axis) only.

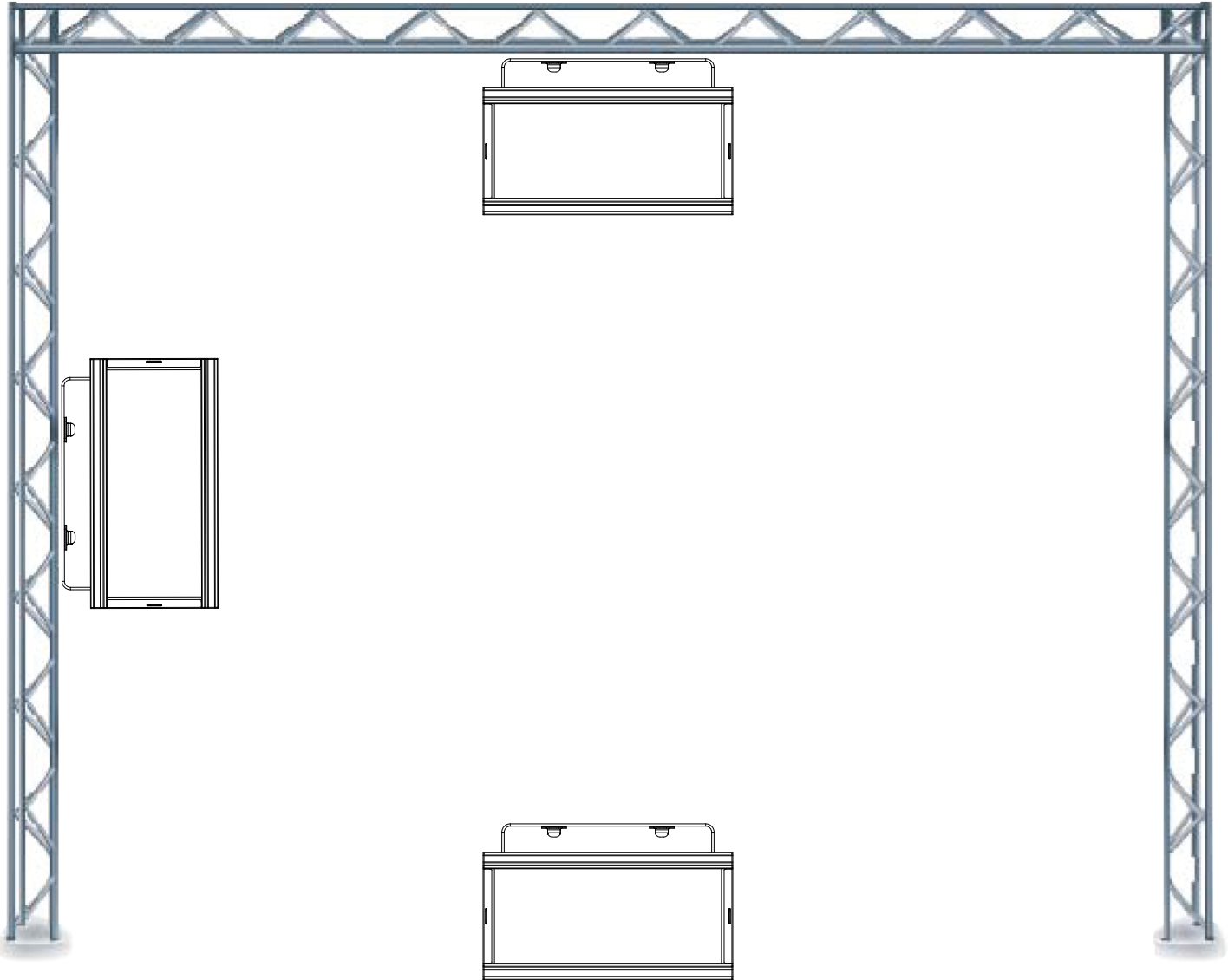

**FALLING FIXTURES CAN CAUSE SEVERE INJURY OR SERIOUS EQUIPMENT DAMAGE! FOR THIS REASON, FIXTURES SHOULD BE INSTALLED AND INSPECTED ONLY BY QUALIFIED PERSONNEL. DO NOT INSTALL THE UNIT IF YOU LACK THE QUALIFICATIONS TO DO SO, OR IF YOU HAVE DOUBTS ABOUT THE SAFETY AND SECURITY OF THE INSTALLATION SETUP OR LOCATION!**



**ALWAYS ATTACH A SAFETY CABLE WHENEVER INSTALLING THIS FIXTURE IN A SUSPENDED ENVIRONMENT TO ENSURE THE FIXTURE WILL NOT FALL IF THE CLAMP FAILS.**

# INSTALLATION GUIDELINES

## POTENTIAL INTERNAL FIXTURE DAMAGE FROM EXTERNAL SOURCES OF LIGHT BEAMS

External sources of light beams from direct sunlight, lighting and moving head fixtures, and lasers, which are focused directly towards the exterior housing and/or penetrate the front lens opening of Elation lighting fixtures, can cause severe internal damage including burning of optics, dichroic color filters, glass and metal gobos, prisms, animation wheels, frost filters, iris, shutters, motors, belts, wiring, discharge lamps, and LEDs.

This issue is not specific only to Elation lighting fixtures, but rather it is a common issue with lighting fixtures from all manufacturers. Although there is no true way to fully prevent this issue from happening, the guidelines below can reduce the risk of potential damage. Contact Elation Service for more details.

**DO NOT EXPOSE THE FIXTURE AND/OR FRONT LENS OPENING TO LIGHT BEAMS FROM DIRECT SUNLIGHT, OTHER LIGHTING OR MOVING HEAD FIXTURES, AND LASERS DURING UNPACKING, INSTALLATION, USE, AND EXTENDED IDLE TIMES OUTDOORS. DO NOT FOCUS A LIGHT BEAM FROM ONE LIGHTING FIXTURE DIRECTLY TOWARDS ANOTHER.**

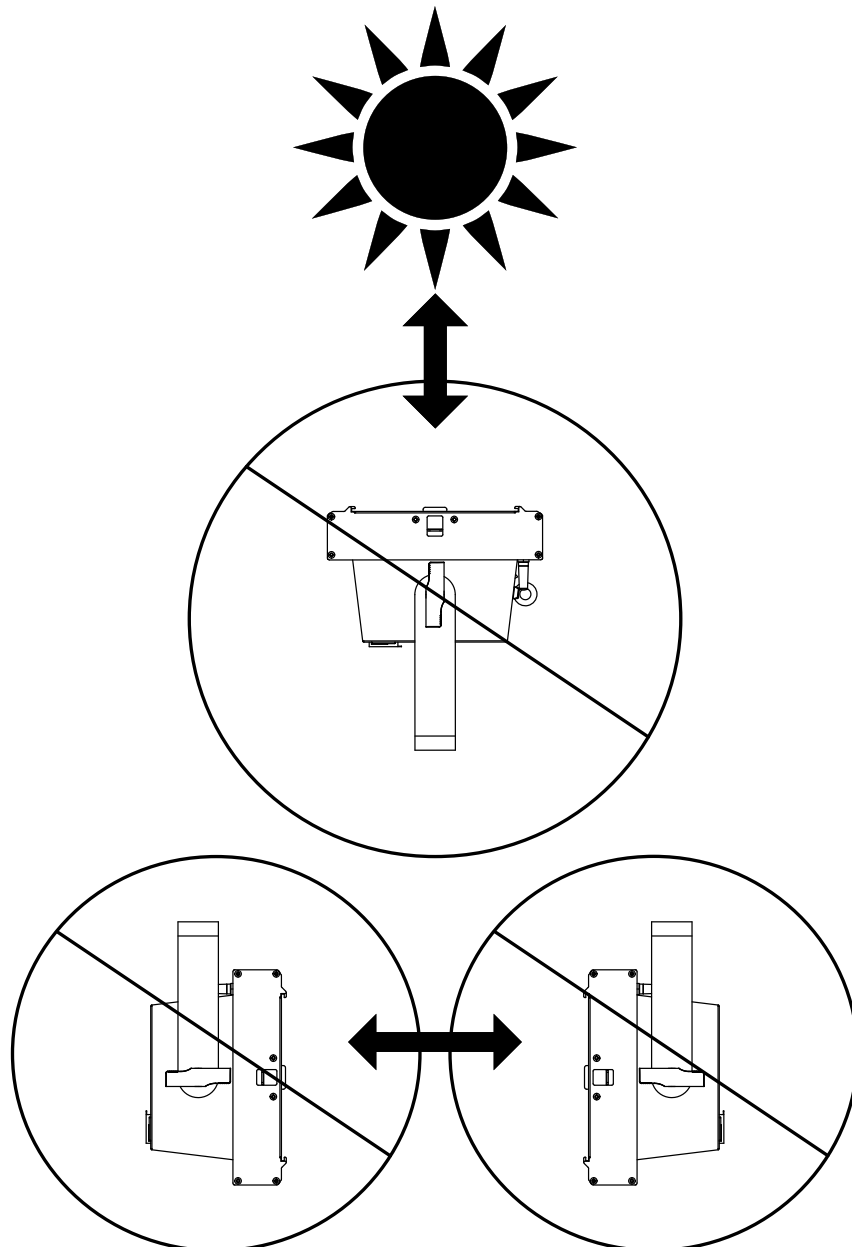

# FAN MODES and LOW NOISE OPERATION

The Jolt Panel FX2 is a high-performance fixture suited for multiple applications. For noise critical environments such as Theater, Opera or Orchestra Halls, it offers various fan operation modes which remove any distraction for the audience and performers. Fan Modes can be changed remotely via the DMX control channel, allowing the fixture to offer high output or whisper silent operation at a moment's notice. All Fan Modes smoothly transition over a brief time, preventing unwanted attraction to the fixture.

**Auto (Default)**—Fans only run at the speeds needed to keep the LED engine within a safe temperature range and ensures optimal performance of the fixture. If possible, they will turn-off, for example, when the fixture is dimmed to a low intensity. Fans sense the ambient and fixture temperature, and will always try to keep noise levels to a minimum. The fixture output will only reduce when the LED engine cannot be cooled down to its safe operating range due to high ambient temperature.

**NOTE: Recommended for daily operation.**

**High**—Fan speeds are increased throughout for the most efficient cooling of the fixture. This mode will increase wear on the fans and should only be utilized in exceptional circumstances. Fans will always run, even if the fixture is dimmed down. Fixture output is kept at 100% unless the LED engine temperature reaches an unsafe temperature at which point the fixture will reduce power carefully to ensure continued safe operation. This mode is only required in very high ambient temperatures when automatic fan speed adjustments are not desired.

## **Low Noise Modes**

For very critical noise environments, the fixture offers two additional Low Noise Modes for silent operation. The fixture output will be reduced, yet due to the extremely high luminous flux, the fixture still offers outstanding performance. In Low Noise Modes, all parameters of the fixture operate more quietly with reduced fan speeds.

**Silent**—75-80% max output, fans run at low speed.

# SYSTEM MENU

The fixture includes an easy to navigate system menu control panel display where all necessary settings and adjustments are made.

- **MENU:** Leave current menu and return to previous menu level.
- **UP:** Scroll up in currently displayed menu.
- **DOWN:** Scroll down in currently displayed menu.
- **ENTER:** Select an option or confirm a selection.

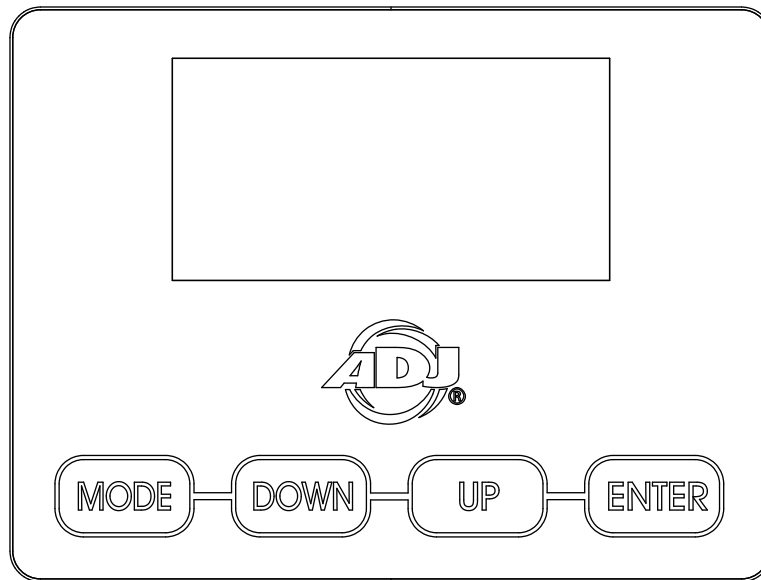

This fixture includes a display lock feature which automatically shuts off the display screen after a certain period of inactivity. This feature is OFF by default, which means that the display will always remain on regardless of inactivity, but can be configured to kick in after up to 10 minutes of inactivity. See the **System Menu** section of this manual for details on how to configure this setting.

# SYSTEM MENU

MAIN MENU	OPTIONS / VALUES (Default Settings in BOLD)		DESCRIPTION	
DMX Settings	DMX Address	001 - 512		
	DMX Mode	6CH, 9CH, 13CH, 16CH, <b>18CH</b> , 20Ch, 36CH, 41CH, 43CH, 51CH, 81CH, 83CH, 126CH, 141CH, 143CH		
	No DMX Status	<b>Hold Last</b> , Blackout, Manual		
Personality	Prim/Sec Mode	Primary, <b>Secondary</b>		
	Select Signal	<b>DMX</b> or Aria		
		Aria and DMX Out		
	Aria Settings	Aria Enable	<b>ON/OFF</b>	
		Set Aria Band	<b>2.4Ghz</b>	
			Subgig (US)	
			Subgig (EU)	
		Aria 2.4Ghz channel	<b>00</b> - 15	
		Aria Subgig channel	<b>00</b> - 09	
		Mesh	<b>ON / OFF</b>	
	RDM	<b>ON / OFF</b>		
	Bluetooth	<b>ON / OFF</b>		
	Fan Settings	<b>Auto</b> , High, Silent		
	Pixel Flip	On/ <b>Off</b>		
	Dim Modes	<b>Standard</b> , Stage, TV, Architectural, Theatre, Stage 2		
		Dim Speed	0s-10s (Default = 0.1s)	
	Dim Curves	<b>Square</b> , Linear, Square Inverse, S-Curve		
	LED Refresh Rate	900Hz - 1500Hz ( <b>1200Hz</b> ), 2500Hz, 4000Hz, 5000Hz, 6000Hz, 10KHz, 15KHz, 20KHz, 25KHz		
	LED Power Limit	50%, 60%, 70%, 80%, 90%, <b>100%</b>		
	Display	Screen Delay	Off, 10s - 5min (Default = <b>1 min</b> )	
		Screen Lock	<b>Off</b> , 10s - 5 min	
		Rotate Display	Yes / <b>No</b> / Auto	
	Temperature Unit	°C/°F	<b>°F</b>	
Service	White Balance (Passcode = <b>011</b> )	Red1 000 - 255		
		Green1 000 - 255		
		Blue1 000 - 255		
		Red2 000 - 255		
		Green2 000 - 255		
		Blue2 000 - 255		
		...		
		Blue32 000 - 255		
Factory Restore	Yes / <b>No</b>			

# SYSTEM MENU

MAIN MENU	OPTIONS / VALUES (Default Settings in BOLD)		DESCRIPTION	
<b>Manual</b>	Red	000-255		
	Green	000-255		
	Blue	000-255		
	White	000-255		
	CCT	000-255		
	Green Shift	000-255		
	RGB Shutter	000- <b>255</b>		
	RGBDimmer	000% - <b>100%</b>		
	White Shutter	000- <b>255</b>		
	Whited Dimmer	000% - <b>100%</b>		
	Self Test	All, Dimmer, Color		
<b>Information</b>	On Time	Current Run Time		
		Total Run Time		
		Last Run Time		
		Reset Last Run Time	Passcode = <b>050</b>	
	Temperature	Current Temp xxx°		
		Max Temp 1 xxx°		
		Max Temp 2 xxx°		
		TempRst.	YES / <b>NO</b>	
	DMX Values	Red		
		Green		
		...		
	Product IDs	RDM UID		
	Error Logs	Fixture Errors		
		Xxxxx	List Errors (Reset Passcode= <b>050</b> )	
		xxxxx		
		Reset Error Log	YES / <b>NO</b>	
	Software Version	1U : V1.01		
		2U1 : V1.01		
		2U2 : V1.01		

# DIMMER MODES AND CURVES

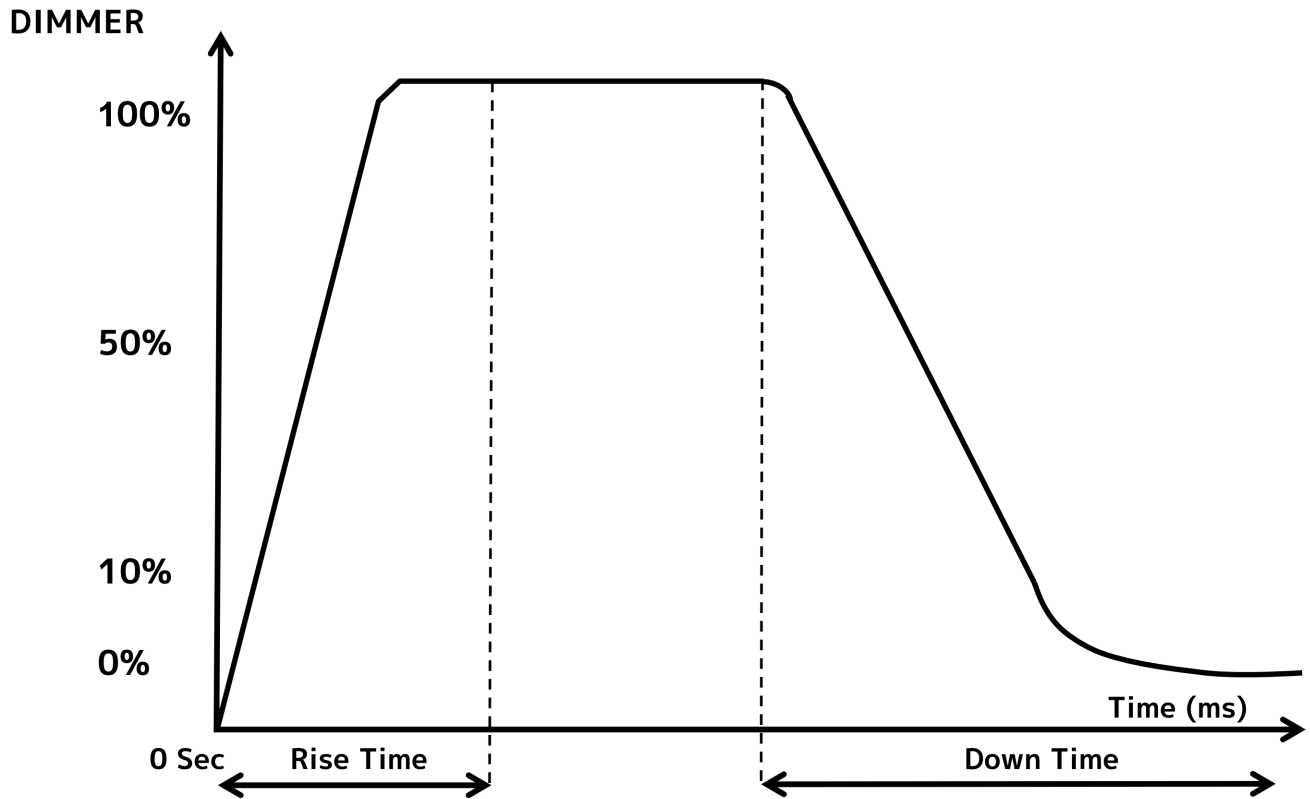

Dimming Curve Ramp Effect	0 sec Fade Time		1 sec Fade Time	
	Rise Time (ms)	Down Time (ms)	Rise Time (ms)	Down Time (ms)
Standard (default)	0	0	0	0
Stage	780	1100	1540	1660
TV	1180	1520	1860	1940
Architectural	1380	1730	2040	2120
Theatre	1580	1940	2230	2280
Stage 2	0	1100	0	1660

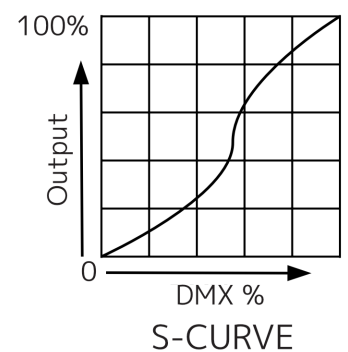
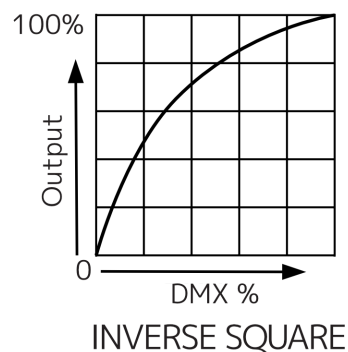
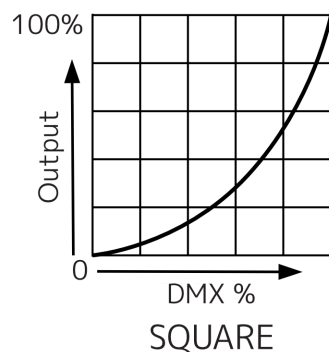
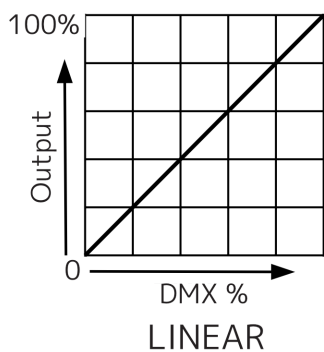

# DMX SETUP

**DMX-512:** DMX is short for Digital Multiplex. This is a universal protocol used as a form of communication between intelligent fixtures and controllers. A DMX controller sends DMX data instructions from the controller to the fixture. DMX data is sent as serial data that travels from fixture to fixture via the DATA “IN” and DATA “OUT” XLR terminals located on all DMX fixtures (most controllers only have a DATA “OUT” terminal).

**DMX Linking:** DMX is a language allowing all makes and models of different manufacturers to be linked together and operate from a single controller, as long as all fixtures and the controller are DMX compliant. To ensure proper DMX data transmission, try to use the shortest cable path possible when using several DMX fixtures. The order in which fixtures are connected in a DMX line does not influence the DMX addressing. For example, a fixture assigned a DMX address of 1 may be placed anywhere in a DMX line: at the beginning, at the end, or anywhere in the middle. When a fixture is assigned a DMX address of 1, the DMX controller knows to send DATA assigned to address 1 to that unit, no matter where it is located in the DMX chain.

**Data Cable (DMX Cable) Requirements (For DMX Operation):**The Jolt Panel FX can be controlled via DMX-512 protocol, and features multiple DMX channel modes. Your unit and your DMX controller require a 5-pin XLR connector for data input and data output. If you are making your own cables, be sure to use standard 110-120 Ohm shielded cable (This cable may be purchased at almost all pro lighting stores). Your cables should be made with a male XLR connector at one end and a female XLR connector on the other. Also remember that DMX cable must be daisy chained and cannot be split.

**Special Note:** Line Termination. When longer runs of cable are used, you may need to use a terminator on the last unit to avoid erratic behavior. A terminator is a 110-120 ohm 1/4 watt resistor which is connected between pins 2 and 3 of a male XLR connector (DATA + and DATA -). This unit is inserted in the female XLR connector of the last unit in your daisy chain to terminate the line. Using a cable terminator (ADJ part number Z-DMX/T) will decrease the chances of erratic behavior.

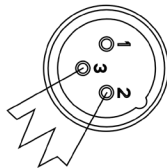
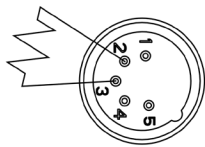

A DMX512 terminator reduces signal errors, avoiding most signal reflection interference. Connect PIN 2 (DMX-) and PIN 3 (DMX+) of the last fixture in series with a 120 Ohm, 1/4 W Resistor to terminate the DMX512.

# DMX SETUP

## DMX ADDRESSING

All fixtures should be given a DMX starting address when operating with a DMX controller, in order to ensure that the correct fixture responds to the correct control signal. This digital starting address is the channel number from which the fixture starts to “listen” to the digital control signal sent out from the DMX controller. The assignment of this starting DMX address is achieved by setting the correct DMX address on the digital control display on the fixture.

You can set the same starting address for all fixtures or a group of fixtures, or set different addresses for each individual fixture. Setting all fixtures to the same DMX address will cause all fixtures to react in the same way. In this case, please note that changing the settings of one channel will affect all the fixtures simultaneously.

If you set each fixture to a different DMX address, each unit will “listen” starting at the channel number you have set, based on the quantity of DMX channels of each fixture. That means changing the settings of one channel will only affect the selected fixture.

As an example, when operating this device in 6 channel mode, you should set the starting DMX address of the first unit to 1, the second unit to 7 (1 + 6), the third unit to 13 (1 + 6 + 6), and so on. (See the chart below for more details.)

Channel Mode	Unit 1 Address	Unit 2 Address	Unit 3 Address	Unit 4 Address
6 Channels	1	7	13	19
9 Channels	1	10	19	28
13 Channels	1	14	27	40
18 Channels	1	19	37	55
20 Channels	1	21	41	61
36 Channels	1	37	73	109
41 Channels	1	42	83	124
43 Channels	1	44	87	130
51 Channels	1	52	103	154
81 Channels	1	82	163	244
83 Channels	1	84	167	250
126 Channels	1	127	253	379
141 Channels	1	142	283	424
143 Channels	1	144	287	430

# DMX TRAITS

CHANNEL														DMX VALUES	FUNCTION
6 CH	9 CH	13 CH	18 CH	20 CH	36 CH	41 CH	43 CH	51 CH	81 CH	83 CH	126 CH	141 CH	143 CH		
1	1	1	1	1										000-255	Outer Red, 0 to 100%
2	2	2	2	2										000-255	Outer Green, 0 to 100%
3	3	3	3	3										000-255	Outer Blue, 0 to 100%
4	4	4												000-255	Inner White, 0 to 100%
5	5	6												000-255	Dimmer, 0 to 100%
6	6	7												000-255	Dimmer Fine, 0 to 100%
	7														<b>Strobe Effect</b>
														000-002	Open
														003-005	Strobe
														006-050	Ramp up
														051-100	Ramp down
														101-150	Ramp up-down
														151-200	Lightning
														201-255	Random
	8														<b>Strobe Rate</b>
														000-255	Speed, slow to fast
	9														<b>Strobe Duration</b>
														000-255	Duration, slow to fast
					1	1	1	1	1	1	1	1	1	000-255	Red 1
					2	2	2	2	2	2	2	2	2	000-255	Green 1
					3	3	3	3	3	3	3	3	3	000-255	Blue 1
					4	4	4	4	4	4	4	4	4	000-255	Red 2
					5	5	5	5	5	5	5	5	5	000-255	Green 2
					6	6	6	6	6	6	6	6	6	000-255	Blue 2
					7	7	7	7	7	7	7	7	7	000-255	Red 3
					8	8	8	8	8	8	8	8	8	000-255	Green 3
					9	9	9	9	9	9	9	9	9	000-255	Blue 3
					10	10	10	10	10	10	10	10	10	000-255	Red 4
					11	11	11	11	11	11	11	11	11	000-255	Green 4
					12	12	12	12	12	12	12	12	12	000-255	Blue 4
					13	13	13	13	13	13	13	13	13	000-255	Red 5
					14	14	14	14	14	14	14	14	14	000-255	Green 5
					15	15	15	15	15	15	15	15	15	000-255	Blue 5
					16	16	16	16	16	16	16	16	16	000-255	Red 6
					17	17	17	17	17	17	17	17	17	000-255	Green 6
					18	18	18	18	18	18	18	18	18	000-255	Blue 6
					19	19	19	19	19	19	19	19	19	000-255	Red 7
					20	20	20	20	20	20	20	20	20	000-255	Green 7
					21	21	21	21	21	21	21	21	21	000-255	Blue 7
					22	22	22	22	22	22	22	22	22	000-255	Red 8
					23	23	23	23	23	23	23	23	23	000-255	Green 8
					24	24	24	24	24	24	24	24	24	000-255	Blue 8
								25	25	25	25	25	25	000-255	Red 9
								26	26	26	26	26	26	000-255	Green 9
								27	27	27	27	27	27	000-255	Blue 9
								28	28	28	28	28	28	000-255	Red 10
								29	29	29	29	29	29	000-255	Green 10
								30	30	30	30	30	30	000-255	Blue 10

# DMX TRAITS

CHANNEL														DMX VALUES	FUNCTION
6 CH	9 CH	13 CH	18 CH	20 CH	36 CH	41 CH	43 CH	51 CH	81 CH	83 CH	126 CH	141 CH	143 CH		
									31	31	31	31	31	000-255	Red 11
									32	32	32	32	32	000-255	Green 11
									33	33	33	33	33	000-255	Blue 11
									34	34	34	34	34	000-255	Red 12
									35	35	35	35	35	000-255	Green 12
									36	36	36	36	36	000-255	Blue 12
									37	37	37	37	37	000-255	Red 13
									38	38	38	38	38	000-255	Green 13
									39	39	39	39	39	000-255	Blue 13
									40	40	40	40	40	000-255	Red 14
									41	41	41	41	41	000-255	Green 14
									42	42	42	42	42	000-255	Blue 14
									43	43	43	43	43	000-255	Red 15
									44	44	44	44	44	000-255	Green 15
									45	45	45	45	45	000-255	Blue 15
									46	46	46	46	46	000-255	Red 16
									47	47	47	47	47	000-255	Green 16
									48	48	48	48	48	000-255	Blue 16
									49	49	49	49	49	000-255	Red 17
									50	50	50	50	50	000-255	Green 17
									51	51	51	51	51	000-255	Blue 17
									52	52	52	52	52	000-255	Red 18
									53	53	53	53	53	000-255	Green 18
									54	54	54	54	54	000-255	Blue 18
									55	55	55	55	55	000-255	Red 19
									56	56	56	56	56	000-255	Green 19
									57	57	57	57	57	000-255	Blue 19
									58	58	58	58	58	000-255	Red 20
									59	59	59	59	59	000-255	Green 20
									60	60	60	60	60	000-255	Blue 20
											61	61	61	000-255	Red 21
											62	62	62	000-255	Green 21
											63	63	63	000-255	Blue 21
											64	64	64	000-255	Red 22
											65	65	65	000-255	Green 22
											66	66	66	000-255	Blue 22
											67	67	67	000-255	Red 23
											68	68	68	000-255	Green 23
											69	69	69	000-255	Blue 23
											70	70	70	000-255	Red 24
											71	71	71	000-255	Green 24
											72	72	72	000-255	Blue 24
											73	73	73	000-255	Red 25
											74	74	74	000-255	Green 25
											75	75	75	000-255	Blue 25

# DMX TRAITS

CHANNEL														DMX VALUES	FUNCTION	
6 CH	9 CH	13 CH	18 CH	20 CH	36 CH	41 CH	43 CH	51 CH	81 CH	83 CH	126 CH	141 CH	143 CH			
												76	76	76	000-255	Red 26
												77	77	77	000-255	Green 26
												78	78	78	000-255	Blue 26
												79	79	79	000-255	Red 27
												80	80	80	000-255	Green 27
												81	81	81	000-255	Blue 27
												82	82	82	000-255	Red 28
												83	83	83	000-255	Green 28
												84	84	84	000-255	Blue 28
												85	85	85	000-255	Red 29
												86	86	86	000-255	Green 29
												87	87	87	000-255	Blue 29
												88	88	88	000-255	Red 30
												89	89	89	000-255	Green 30
												90	90	90	000-255	Blue 30
												91	91	91	000-255	Red 31
												92	92	92	000-255	Green 31
												93	93	93	000-255	Blue 31
												94	94	94	000-255	Red 32
												95	95	95	000-255	Green 32
												96	96	96	000-255	Blue 32
												97	97	97	000-255	Red 33
												98	98	98	000-255	Green 33
												99	99	99	000-255	Blue 33
												100	100	100	000-255	Red 34
												101	101	101	000-255	Green 34
												102	102	102	000-255	Blue 34
												103	103	103	000-255	Red 35
												104	104	104	000-255	Green 35
												105	105	105	000-255	Blue 35
												106	106	106	000-255	Red 36
												107	107	107	000-255	Green 36
												108	108	108	000-255	Blue 36
												109	109	109	000-255	Red 37
												110	110	110	000-255	Green 37
												111	111	111	000-255	Blue 37
												112	112	112	000-255	Red 38
												113	113	113	000-255	Green 38
												114	114	114	000-255	Blue 38
												115	115	115	000-255	Red 39
												116	116	116	000-255	Green 39
												117	117	117	000-255	Blue 39
												118	118	118	000-255	Red 40
												119	119	119	000-255	Green 40
												120	120	120	000-255	Blue 40

# DMX TRAITS

CHANNEL														DMX VALUES	FUNCTION	
6 CH	9 CH	13 CH	18 CH	20 CH	36 CH	41 CH	43 CH	51 CH	81 CH	83 CH	126 CH	141 CH	143 CH			
				4			25			61				121		<b>CT Presets</b>
															000-022	Open
															023-089	CTO 2300K - 8900K
															090-255	9000K
				5			26			62				122	000-255	<b>Green Shift</b>
		5	4	6		25	27	31	61	63		121	123	000-255	<b>Outer Color Macros</b>	
			5	7	25	26	28	32	62	64		122	124	000-255	<b>Outer Dimmer, 0 to 100%</b>	
			6	8	26	27	29	33	63	65		123	125	000-255	<b>Outer Dimmer Fine, 0 to 100%</b>	
																<b>Outer Strobe Effect</b>
															000-002	Open
															003-005	Strobe
		8	7	9	27	28	30	34	64	66		124	126	006-050	Ramp up	
														051-100	Ramp down	
														101-150	Ramp up-down	
														151-200	Lightning	
														201-255	Random	
		9	8	10	28	29	31	35	65	67		125	127		<b>Outer Strobe Rate</b>	
														000-255	Speed, slow to fast	
		10	9	11	29	30	32	36	66	68		126	128		<b>Outer Strobe Duration</b>	
														000-255	Duration, slow to fast	
																<b>Outer Program Macro</b>
															000-005	No function
															006-015	Macro 1
															016-025	Macro 2
															026-035	Macro 3
															036-045	Macro 4
															046-055	Macro 5
															056-065	Macro 6
															066-075	Macro 7
		11	10	12		31	33	37	67	69		127	129	076-085	Macro 8	
															086-095	Macro 9
															096-105	Macro 10
															106-115	Macro 11
															116-125	Macro 12
															126-135	Macro 13
															136-145	Macro 14
															146-155	Macro 15
															156-165	Macro 16
															166-175	Macro 17
															176-185	Macro 18
															186-195	Macro 19

# DMX TRAITS

CHANNEL														DMX VALUES	FUNCTION		
6 CH	9 CH	13 CH	18 CH	20 CH	36 CH	41 CH	43 CH	51 CH	81 CH	83 CH	126 CH	141 CH	143 CH				
																	<b>Outer Program Macro (continued)</b>
															196-205		Macro 20
															206-215		Macro 21
		11	10	12		31	33	37	67	69			127	129	216-225		Macro 22
															226-235		Macro 23
															236-245		Macro 24
															246-255		Macro 25
			11	13		32	34	38	68	70			128	130	000-255		<b>Outer Program Macro Speed</b>
								39	69	71	121	129	131	000-255			<b>White 1</b>
								40	70	72	122	130	132	000-255			<b>White 2</b>
								41	71	73	123	131	133	000-255			<b>White 3</b>
								42	72	74	124	132	134	000-255			<b>White 4</b>
								43	73	75	125	133	135	000-255			<b>White 5</b>
								44	74	76	126	134	136	000-255			<b>White 6</b>
					30	33	35							000-255			<b>Inner White Group 1</b>
					31	34	36							000-255			<b>Inner White Group 2</b>
			12	14	32	35	37	45	75	77			135	137	000-255		<b>Inner Dimmer, 0 to 100%</b>
			13	15	33	36	38	46	76	78			136	138	000-255		<b>Inner Dimmer Fine, 0 to 100%</b>
																	<b>Inner Strobe Effect</b>
															000-002		Open
															003-005		Strobe
			14	16	34	37	39	47	77	79			137	139	006-050		Ramp up
															051-100		Ramp down
															101-150		Ramp up-down
															151-200		Lightning
															201-255		Random
			15	17	35	38	40	48	78	80			138	140			<b>Inner Strobe Rate</b>
															000-255		Speed, slow to fast
			16	18	36	39	41	49	79	81			139	141			<b>Inner Strobe Duration</b>
															000-255		Duration, slow to fast
																	<b>Inner Program Macro</b>
															000-005		No Function
															006-033		Macro 1
															034-060		Macro 2
															061-088		Macro 3
		12	17	19		40	42	50	80	82			140	142	089-116		Macro 4
															117-144		Macro 5
															145-172		Macro 6
															173-200		Macro 7
															201-228		Macro 8
															229-255		Macro 9
			18	20		41	43	51	81	83			141	143	000-255		<b>Inner Program Macro Speed</b>
		13													000-255		<b>In/Out Program Macro Speed, slow to fast</b>

# REMOTE DEVICE MANAGEMENT (RDM)

**NOTE: for RDM to work properly, RDM enabled equipment must be used throughout the entire system, including DMX data splitters and wireless systems.**

Remote Device Management (RDM) is a protocol that sits on top of the DMX512 data standard for lighting, allowing the DMX systems of the fixtures to be modified and monitored remotely. This protocol is ideal for instances in which a unit is installed in a location that is not easily accessible.

With RDM, the DMX512 system becomes bi-directional, allowing a compatible RDM enabled controller to send out a signal to devices on the wire, as well as allowing the fixture to respond (known as a GET command). The controller can then use its SET command to modify settings that would typically have to be changed or viewed directly via the unit's display screen, including the DMX Address, DMX Channel Mode, and Temperature Sensors.

## FIXTURE RDM INFORMATION:

RDM Code	Device ID	Device Model ID	Personality ID
1900	0000-FFFF	79	6CH, 9CH, 13CH, 18CH, 36CH, 41CH, 51CH, 81CH, 126CH, 141CHLK

**Please be aware that not all RDM devices support all RDM features, and therefore it is important to check beforehand to ensure that the equipment that you are considering includes all of the features that you require.**

The following parameters are accessible in RDM on this device:

Parameter ID	Code
Sensor Definition	[0x0200]
Sensor Value	[0x0201]
Device Model Description	[0x0080]
Manufacturer Label	[0x0081]
Device Label	[0x0082]
DMX Personality	[0x00E0]
DMX Personality Description	[0x00E1]
Device Hours	[0x0400]
Comms Status	[0x0015]
Status ID Description	[0x0031]
Clear Status ID	[0x0032]
Device Power Cycles	[0x0405]
Display Invert	[0x0500]
Display Level	[0x0501]
Realtime Clock	[0x0603]
Power State	[0x1010]
Preset Playback	[0x1031]
Slot Information	[0x0120]
Slot Description	[0x0122]
Default Slot Value	[0x0122]
Language	[0x00B0]
Language Capabilities	[0x00A0]
Boot Software Version Label	[0x00C2]
Boot Software Version ID	[0x00C1]
Product Detail ID List	[0x0070]
Status Messages	[0x0030]

# ERROR CODES

Note: Error Codes are subject to change without any prior written notice.

<b>ERROR CODES</b>	<b>DESCRIPTION</b>
Temp Error	This message will appear after a fixture reset if there is a Temperature Error or Fan Error
Fan Error	

# PIXEL ZONES

**Fixture without Lens**

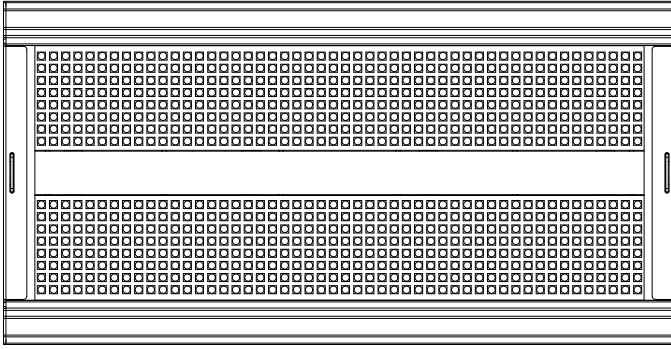

**Fixture with Lens Installed**



## PIXEL FLIP ON



## PIXEL FLIP OFF



# PIXEL ZONES

## 6 / 9 / 13 / 16 / 20 CH

Outer	
Inner White Group 1	Inner White Group 2
Outer	

## 36 / 41 / 43 CH

Outer RGB Group 1	Outer RGB Group 2
Outer RGB Group 3	Outer RGB Group 4
Inner White Group 1	Inner White Group 2
Outer RGB Group 5	Outer RGB Group 6
Outer RGB Group 7	Outer RGB Group 8

## 51 CH

1	1	2	2	3	3	4	4	5	5
1	1	2	2	3	3	4	4	5	5
W1		W2		W3		W4		W5	
6	6	7	7	8	8	9	9	10	10
6	6	7	7	8	8	9	9	10	10

## 81 / 83 CH

1	2	3	4	5	6	7	8	9	10
1	2	3	4	5	6	7	8	9	10
W1		W2		W3		W4		W5	
11	12	13	14	15	16	17	18	19	20
11	12	13	14	15	16	17	18	19	20

## 126 / 141 / 143 CH

1	2	3	4	5	6	7	8	9	10
11	12	13	14	15	16	17	18	19	20
W1		W2		W3		W4		W5	
21	22	23	24	25	26	27	28	29	30
31	32	33	34	35	36	37	38	39	40

## DAISY CHAIN POWER LINKING

These units have the capability to be daisy chained together via the power in/out ports. **The maximum number of units that can be linked together in this manner is as follows:**

- 4 units maximum when running on 120V power.
- 8 units maximum when running on 230V power.

**DO NOT EXCEED THE NUMBER OF UNITS LISTED ABOVE.**

**DO NOT MIX MAKE AND MODEL TYPES WHEN DAISY CHAINING!** All units that are connected in this manner must be of the same make and model type.

## CLEANING AND MAINTENANCE



**DISCONNECT POWER BEFORE PERFORMING ANY MAINTENANCE!**

### CLEANING

Frequent cleaning is recommended to ensure proper function, optimized light output, and an extended life. The frequency of cleaning depends on the environment in which the fixture operates: damp, smoky, or particularly dirty environments can cause greater accumulation of dirt on the fixture's optics. Clean the external lens surface periodically with a soft cloth to avoid dirt/debris accumulation.

**NEVER** use alcohol, solvents, or ammonia-based cleaners.

### MAINTENANCE

Regular inspections are recommended to ensure proper function and extended life. There are no user serviceable parts inside this fixture. Please refer all other service issues to an authorized ADJ service technician. Should you need any spare parts, please order genuine parts from your local ADJ dealer.

Please refer to the following points during routine inspections:

- A detailed electrical check by an approved electrical engineer every three months, to make sure the circuit contacts are in good condition and prevent overheating.
- Be sure all screws and fasteners are securely tightened at all times. Loose screws may fall out during normal operation, resulting in damage or injury as larger parts could fall.
- Check for any deformations on the housing, color lenses, rigging hardware, and rigging points (ceiling, suspension, trussing). Deformations in the housing could allow for dust or liquids to enter into the fixture. Damaged rigging points or unsecured rigging could cause fixture to fall and seriously injure a person(s).
- Electric power supply cables must not show any damage, material fatigue, or sediments.

**NEVER** remove the ground prong from the power cable.

# SPECIFICATIONS

## Light Source:

- 800 x 0.5W RGB SMD LEDs + 48 x 5W Cool White SMD LEDs
- 73° Beam Angle
- 111° Field Angle
- Color Temperature: Red: 620-630nm. Green: 515-525nm. Blue: 460-470nm.
- White LEDs CCT: Typical 7400K (Min 6900 - Max 8000), 472nm
- CRI: 69.4
- 50,000 Hour Average LED Life

## Features:

- 40 x RGB LED zones (126, 141 and 143CH Modes)
- 6 x Cool White LED zones (51, 81, 83, 126, 141 and 143CH Modes)
- 67 Built-In Color Temperature Presets (2300K-8900K)
- 25 built-in RGB LED Program Macros
- 9 built-in Cool White LED Program Macros
- Integrated Aria X2 Management Suite
- Channel for Light Shaping Filters (to Blur Pixel Dots)
- Includes Frost Lens Filter
- Built-in Receivers to Connect an Omega Bracket (sold separately)

## Control:

- Control Protocol: DMX, Aria X2 and RDM
- 14 DMX Modes: 6, 9, 13, 18, 20, 36, 41, 43, 51, 81, 83, 126, 141, and 143 channel modes
- Dim Modes: 6 Presets (Standard, Stage, TV, Architectural, Theatre & Stage 2)
- Dim Curves: 4 Presets (Linear, Square Law, Inv Square Law and S Curve)
- 0-100% Smooth Dimming
- Strobe: Ramp Up / Down, Lighting and Random
- Max Strobe Rate 20Hz. Min Strobe Rate: 1Hz.
- Selectable LED Refresh Rate: 900Hz - 25kHz
- With Wired Digital Communication Network
- Display: OLED display with 4-button touch menu

## Connections:

- Data: IP65 Indoor locking 5-pin DMX In/Out
- Power: IP65 Indoor locking power In/Out

## Electrical:

- 100-240V 50Hz/60Hz (Auto Sensing)
- Max Power Consumption: 214W @120V., 208W @230V.
- Max Power Link: 6pcs @120V., 12pcs @230V.
- Fuse Protected: T5A/250V Glass Fuse (5\*20MM)

## Dimensions / Weight:

- Length: 5.28" (134.2mm)
- Width: 16.42" (417mm)
- Height: 10.26" (260.5mm)
- Weight: 13.67 lbs. (6.2 kg)

## What's Included:

- 1x IP65 Locking Power Cable
- 1x Frost Filter

## Optional Accessories:

- 180mm Omega Bracket (Part #: Z-7021600059)
- JPFXBLKF (Sku: JPF001 - Black Filter for Jolt Panel FX2 and Jolt Panel FXIP)
- JPFX1X60LF (Sku: JPF014 - 1x60° Linear Effect Filter for Jolt Panel FX2 and Jolt Panel FXIP)
- JPFX60X1LF (Sku: JPF027 - 60X1° Linear Effect Filter for Jolt Panel FX2 and Jolt Panel FXIP)

## Approvals and Ratings:

- CE, cETLus (#4010765), IP20

Specifications and documentation subject to change without notice.

# DIMENSIONS

Dimensions are not drawn to scale.

