



HYDRO WASH X19

User Manual

©2023 ADJ Products, LLC all rights reserved. Information, specifications, diagrams, images, and instructions herein are subject to change without notice. ADJ Products, LLC logo and identifying product names and numbers herein are trademarks of ADJ Products, LLC. Copyright protection claimed includes all forms and matters of copyrightable materials and information now allowed by statutory or judicial law or hereinafter granted. Product names used in this document may be trademarks or registered trademarks of their respective companies and are hereby acknowledged. All non-ADJ Products, LLC brands and product names are trademarks or registered trademarks of their respective companies.

ADJ Products, LLC and all affiliated companies hereby disclaim any and all liabilities for property, equipment, building, and electrical damages, injuries to any persons, and direct or indirect economic loss associated with the use or reliance of any information contained within this document, and/or as a result of the improper, unsafe, insufficient and negligent assembly, installation, rigging, and operation of this product.

ADJ USA | 6122 S. Eastern Ave. | Los Angeles, CA. 90040
 323-582-2650 | 323-532-2941 fax | www.adj.com | support@americandj.com

ADJ Supply Europe B.V. | Junostraat 2 | 6468 EW Kerkrade, The Netherlands
 +31 (0)45 546 85 00 | +31 45 546 85 99 fax | www.adj.eu | support@adjgroup.eu

ADJ Mexico | AV Santa Ana 30 | Parque Industrial Lerma, Lerma, Mexico 52000
 +52 (728) 282-7070

DOCUMENT VERSION



Due to additional product features and/or enhancements, an updated version of this document may be available online.

Please check www.adj.com for the latest revision/update of this manual

Date	Document Version	Software Version	DMX Channels	Notes
06/29/2020	1.0	1.1	16 / 88 / 90	Initial Release
08/13/2020	1.1	NC	No Change	Updated System menu / error codes
10/08/2020	1.2	NC	No Change	Updated zoom range value
07/14/2021	1.3	1.2	16 / 26 / 88 / 90	Added 26-ch DMX mode; added Pixel Zones; updated Features, Safety Guidelines, Fixture Installation, System Menu, & Technical Specs
08/10/2021	1.4	N/C	No Change	Updated Overview, System Menu, WiFly Control, and Specifications, removed Software Updates
03/07/2022	1.5	3.0	16 / 20 / 26 / 30 / 88 / 90	Updated Features, System Menu, DMX Addressing, DMX Traits, Specifications.
05/13/2022	1.6	N/C	No Change	Updated Overview, Pixel Zones, System Menu.
12/13/2022	1.7	N/C	N/C	Updated IP65 Notes in Specifications
01/10/2023	1.8	N/C	N/C	Updated RDM & DMX Traits

CONTENTS

Introduction	4
Limited Warranty	5
IP65 Notice	6
Safety Guidelines	7
Transportation & Handling	10
Overview	11
Torque Settings & IP Tester	12
Torque Screw Locations	13
Fixture Installation	14
Omega Bracket & Truss Clamp	15
Truss Installation	16
Direct Light Source	17
Connecions	18
Remote Device Management (RDM)	19
Fan Modes & Low Noise Operation	20
DMX Setup	21
System Menu	22
WiFly Control	29
Target Modes	31
Dimmer Curve Chart	33
DMX Addressing	34
DMX Traits	35
Color Macro Chart	40
Color Temperature Chart	42
Pixel Zones	43
Error Codes	44
Multiple Unit Power Linking Cleaning	45
Specifications	46
Dimensions	47

GENERAL

INTRODUCTION

This fixture has been designed to perform reliably for years when the information in this manual are followed. Please read and understand all the instructions and guidelines carefully and thoroughly before operating this unit. This manual contains important information regarding safety, installation, use, and maintenance.

UNPACKING

Each fixture has been thoroughly tested and shipped in perfect operating condition. Carefully check the outer shipping carton for signs of any damage that may have occurred during shipping. If the outer carton appears to be damaged, carefully inspect the fixture for damage and be sure all included accessories have arrived intact. In the event damage has been found and/or parts are missing, please contact our customer support team for further instructions. Please do NOT return this fixture to your dealer without first contacting customer support at the number listed below. Please do NOT discard the outer shipping carton in the trash. Please recycle whenever possible.

FEATURES

IP65 Rated (temporary outdoor use)

Electronic Dimming 0-100%

DMX-512 Protocol

IP65, 5-pin XLR, Data Locking In/Out Connections

16, 20, 26, 30, 88, & 90 Channel DMX Control Modes

IP65 Locking Power In/Out Connections

6° to 40° Motorized Linear Zoom

Multiple Unit Power Linking (see section on Multiple Unit Power Linking)

INCLUDED ITEMS

- IP65 Locking Main Power Cable (1x)
- Omega Brackets (x2)

CUSTOMER SUPPORT: Contact ADJ Service for any product related service and support needs. Also visit forums.adj.com with questions, comments or suggestions.

ADJ SERVICE USA - Monday - Friday 8:00am to 4:30pm PST

Voice: 800-322-6337 | Fax: 323-582-2941 | support@adj.com

ADJ SERVICE EUROPE - Monday - Friday 08:30 to 17:00 CET

Voice: +31 45 546 85 60 | Fax: +31 45 546 85 96 | support@adj.eu

REPLACEMENT PARTS please visit parts.adj.com

WARRANTY RETURNS

All returned service items, whether under warranty or not, must be freight pre-paid and accompanied by a return authorization (R.A.) number. The R.A. number must be clearly written on the outside of the return package. A brief description of the problem as well as the R.A. number must also be written down on a piece of paper and included in the shipping container. If the unit is under warranty, you must provide a copy of your proof of purchase invoice. Items returned without an R.A. number clearly marked on the outside of the package will be refused and returned at customer's expense. You may obtain an R.A. number by contacting customer support.

LIMITED WARRANTY (USA ONLY)

- A. ADJ Products, LLC hereby warrants, to the original purchaser, ADJ Products, LLC products to be free of manufacturing defects in material and workmanship for a prescribed period from the date of purchase (see specific warranty periods below). This warranty shall be valid only if the product is purchased within the United States of America, including possessions and territories. It is the owner's responsibility to establish the date and place of purchase by acceptable evidence, at the time service is sought.
- B. For warranty service you must obtain a Return Authorization number (RA#) before sending back the product—please contact ADJ Products, LLC Service Department at 800-322-6337. Send the product only to the ADJ Products, LLC factory. All shipping charges must be pre-paid. If the requested repairs or service (including parts replacement) are within the terms of this warranty, ADJ Products, LLC will pay return shipping charges only to a designated point within the United States. If the entire instrument is sent, it must be shipped in its original package. No accessories should be shipped with the product. If any accessories are shipped with the product, ADJ Products, LLC shall have no liability whatsoever for loss of or damage to any such accessories, or for the safe return thereof.
- C. This warranty is void if the serial number has been altered or removed; if the product is modified in any manner which ADJ Products, LLC concludes, after inspection, affects the reliability of the product; if the product has been repaired or serviced by anyone other than the ADJ Products, LLC factory unless prior written authorization was issued to purchaser by ADJ Products, LLC; if the product is damaged because not properly maintained as set forth in the instruction manual.
- D. This is not a service contract, and this warranty does not include maintenance, cleaning or periodic checkup. During the period specified above, ADJ Products, LLC will replace defective parts at its expense with new or refurbished parts and will absorb all expenses for warranty service and repair labor by reason of defects in material or workmanship. The sole responsibility of ADJ Products, LLC under this warranty shall be limited to the repair of the product, or replacement thereof, including parts, at the sole discretion of ADJ Products, LLC. All products covered by this warranty were manufactured after August 15, 2012, and bear identifying marks to that effect.
- E. ADJ Products, LLC reserves the right to make changes in design and/or improvements upon its products without any obligation to include these changes in any products theretofore manufactured. No warranty, whether expressed or implied, is given or made with respect to any accessory supplied with products described above. Except to the extent prohibited by applicable law, all implied warranties made by ADJ Products, LLC in connection with this product, including warranties of merchantability or fitness, are limited in duration to the warranty period set forth above. And no warranties, whether expressed or implied, including warranties of merchantability or fitness, shall apply to this product after said period has expired. The consumer's and/or Dealer's sole remedy shall be such repair or replacement as is expressly provided above; and under no circumstances shall ADJ Products, LLC be liable for any loss or damage, direct or consequential, arising out of the use of, or inability to use, this product. This warranty is the only written warranty applicable to ADJ Products, LLC Products and supersedes all prior warranties and written descriptions of warranty terms and conditions heretofore published.

LIMITED WARRANTY PERIODS

- **Non-LED Lighting Products = 1-Year (365 Days)** (Including Special Effect Lighting, Intelligent Lighting, UV lighting, Strobes, Fog Machines, Bubble Machines, Mirror Balls, Par Cans, Trussing, Lighting Stands, Power/Data Distribution, etc. excluding LED and lamps)
- **Laser Products = 1-Year (365 Days)** (excluding laser diodes which have a 6-Month Limited Warranty)
- **LED Products = 2-Year (730 Days)** (excluding batteries which have a 180 Day Limited Warranty)
PLEASE NOTE: 2-Year (730 Days) Limited Warranty ONLY applies to product purchased within the USA.
- **StarTec Series = 1-Year (365 Days)** (excluding batteries which have a 180 Day Limited Warranty)
- **ADJ DMX Controllers = 2 Year (730 Days)**
- **American Audio Products = 1 Year (365 Days)**

IP65 RATED

The **International Protection (IP)** rating system is commonly expressed as “**IP**” (Ingress Protection) followed by two numbers (i.e. IP65), where the numbers define the degree of protection. The first digit (Foreign Bodies Protection) indicates the extent of protection against particles entering the fixture, and the second digit (Water Protection) indicates the extent of protection against water entering the fixture. An **IP65** rated lighting fixture is designed and tested to protect against the ingress of dust (6), and low-pressure water jets from any direction (5).

NOTE: THIS FIXTURE IS INTENDED FOR TEMPORARY OUTDOOR USE ONLY!

Maritime/Coastal Environment Installations: A coastal environment is seaside adjacent, and caustic to electronics through exposure to atomized salt-water and humidity, whereas maritime is anywhere within 5-miles of a coastal environment.



NOT suitable for maritime/coastal environment installations. Installing this fixture in a maritime/coastal environment may cause corrosion and/or excessive wear to the interior and/or exterior components of the fixture. Damages and/or performance issues resulting from installation in a maritime/coastal environment will void the manufactures warranty, and will NOT be subject to any warranty claims and/or repairs.

Maritime installations require additional preparation, and additional service intervals may be needed given the maritime use. In general, IP ratings presuppose freshwater conditions VS maritime conditions, which are typically more “caustic” to IP fixtures (both internally and externally). A duty-cycle may also be needed when units are not in use. During times of high humidity and colder temperatures, condensation may occur internally so the fixture may require a duty-cycle to bring it up to running temperature, allowing any accumulation of moisture to be expelled via the vent valve. Recommendations can change based on installation environmental circumstances. A waterproof dome or similar device is recommended for use in permanent outdoor installations. When using a dome, refer to manufacturer recommendations for duty-cycle.

NOTE: NOT ALL FEATURES LISTED ARE AVAILABLE ON ALL FIXTURES; THE FOLLOWING INSTRUCTIONS MAY NOT APPLY. CONTACT SUPPORT FOR ADDITIONAL DETAILS.

Exterior Maintenance: Inspect the exterior every 30-days. The unit must be powered off/disconnected. Inspect optics to determine if the lens is obstructed, then clean optics and chassis accordingly. Based on initial finding, schedule maintenance accordingly, keeping in mind that exterior maintenance will be required. Even if the luminaires are NOT in use, maintenance will still be needed given its location (exterior use). The use of a durable type of wax on the chassis is recommended since it will help prevent contaminant build up. Inspect both power and data lines for any signs of contaminants or corrosion. Periodically reapplying di-electric grease, especially in coastal environments. If any signs of corrosion/contaminants are present, clean thoroughly, and/or replace connectors, then reapply di-electric grease. Typically, this should be done annually, or any time an opportunity presents itself. As a preventive measure, annual replacement of both vent valves is recommended. The vent valve membrane can become contaminated and/or clogged causing improper venting of humidity within the luminaire. Inspect all mounting hardware as a precaution.

Interior Maintenance: Inspect the interior every 30-days. The unit must be powered off/disconnected.

- Inspect zoom/focus mechanism, clean optics, lubricate linear bearings (Krytox oil) as needed, inspect belts for wear
- Inspect all rotating effect wheels, manually rotate them, note any resistance
- Inspect all remaining rotating belts for any wear
- Inspect all fans, clean as needed, check rotation, check connections
- Inspect CMY module, manually move flags and check for signs of resistance, and if needed, clean guide rods first, then reapply a thin layer of grease (moly lube)
- Clean interior with low-volume compressed air, then clean optics prior to reassembly of head covers

Although the base has limited moving parts, the pan belt should also be inspected for wear. Remember to always perform an IP test anytime a cover is removed.

There is no specific time frame regarding the routine replacement of parts such as belts/stepper motors, PCBs, or LEDs. These items should only be replaced on an as needed bases, except for cooling fans, which should be replaced once the luminaries reach 10,000-hours. This is a prophylactic measure intended to keep the unit running as cool as possible, insuring proper function of all internal components. A complete service breakdown is available, please contact service@adj.com for any needed parts or manuals.

SAFETY GUIDELINES

For Your Own Personal Safety, Please Read and Understand This Manual Completely Before You Attempt To Install Or Operate This Unit!

- **THERE ARE NO USER SERVICEABLE PARTS INSIDE THIS UNIT. DO NOT ATTEMPT ANY REPAIRS YOURSELF, AS DOING SO WILL VOID YOUR MANUFACTURER'S WARRANTY. DAMAGES RESULTING FROM MODIFICATIONS TO THIS FIXTURE AND/OR THE DISREGARD OF SAFETY INSTRUCTIONS AND GUIDELINES IN THIS MANUAL VOID THE MANUFACTURER'S WARRANTY AND ARE NOT SUBJECT TO ANY WARRANTY CLAIMS AND/OR REPAIRS.**
- **DO NOT PLUG THE FIXTURE INTO A DIMMER PACK!**
- **NEVER OPEN THIS FIXTURE WHILE IN USE!**
- **UNPLUG POWER BEFORE SERVICING FIXTURE!**
- **NEVER TOUCH THE FIXTURE DURING OPERATION AS IT MAY BE HOT!**
- **KEEP FLAMMABLE MATERIALS AWAY FROM FIXTURE!**
- **ENSURE ALL CONNECTIONS AND END CAPS ARE PROPERLY SEALED WITH A DIELECTRIC GREASE (AVAILABLE AT MOST ELECTRICAL SUPPLIERS) TO PREVENT WATER CORROSION AND/OR ELECTRICAL SHORT CIRCUIT.**
- **IF THE FIXTURE IS EXPOSED TO ENVIRONMENTAL TEMPERATURE CHANGES, SUCH AS RELOCATION FROM AN OUTDOOR COLD TO AN INDOOR WARM ENVIRONMENT, DO NOT POWER THE FIXTURE ON IMMEDIATELY. INTERNAL CONDENSATION AS A RESULT OF ENVIROMENTAL TEMPERATURE CHANGE CAN CAUSE INTERNAL FIXTURE DAMAGE. LEAVE THE FIXTURE POWERED OFF UNTIL IT HAS REACHED ROOM TEMPERATURE BEFORE POWERING ON.**
- **NEVER LOOK DIRECTLY INTO THE LIGHT SOURCE! RETINA INJURY RISK - MAY INDUCE BLINDNESS! SENSITIVE PERSONS MAY SUFFER AN EPILEPTIC SHOCK!**
- Be sure that the power outlet matches the required voltage for your unit.
- Do not attempt to operate this unit if the power cord has been frayed or broken.
- Do not attempt to remove or break off the ground prong from the electrical cord. This prong is used to reduce the risk of electrical shock and fire in case of an internal short.
- Disconnect from main power before making any type of connection.
- Do not remove the cover fro any reason. There are no user serviceable parts inside.
- Never operate this unit with the cover removed.
- Always be sure to mount this unit in an area that will allow proper ventilation. Allow about 7.9" (20cm) between this device and a wall.
- Do not attempt to operate this unit if it has been damaged in any way.
- Always mount this unit in safe and stable matter.
- Power-supply cords should be routed so that they are not likely to be walked on or pinched by items placed upon or against them, paying particular attention to cords at plugs, convenience receptacles, and the point at which they exit from the appliance.
- Cleaning - The fixture should be cleaned only as recommended by the manufacturer. See the Cleaning section of this manual for details.
- Heat - This fixture should be situated away from heat sources such as radiators, heat registers, stoves, or other appliances (including amplifiers) that produce heat.
- The fixture should be serviced by qualified service personnel when the appliance does not appear to operate normally or exhibits a marked change in performance.

SAFETY GUIDELINES

To guarantee a smooth operation, it is important to follow all instructions and guidelines in this manual. ADJ Products, LLC is not responsible for injury and/or damages resulting from the misuse of this fixture due to the disregard of the information printed in this manual. Only qualified and/or certified personnel should perform installation of this fixture and only the original rigging parts included with this fixture should be used for installation. Any modifications to the fixture and/or the included mounting hardware will void the original manufactures warranty and increase the risk of damage and/or personal injury.



PROTECTION CLASS 1 - FIXTURE MUST BE PROPERLY GROUNDED



THERE ARE NO USER SERVICEABLE PARTS INSIDE THIS UNIT. DO NOT ATTEMPT ANY REPAIRS YOURSELF; DOING SO WILL VOID YOUR MANUFACTURES WARRANTY. DAMAGES RESULTING FROM MODIFICATIONS TO THIS FIXTURE AND/OR THE DISREGARD OF SAFETY INSTRUCTIONS AND GUIDELINES IN THIS MANUAL VOID THE MANUFACTURES WARRANTY AND ARE NOT SUBJECT TO ANY WARRANTY CLAIMS AND/OR REPAIRS.



**DO NOT PLUG FIXTURE INTO A DIMMER PACK!
NEVER OPEN THIS FIXTURE WHILE IN USE!
UNPLUG POWER BEFORE SERVICING FIXTURE!
NEVER TOUCH FIXTURE DURING OPERATION AS IT MAY BE HOT!
KEEP FLAMMABLE MATERIALS AWAY FROM FIXTURE!**



ENSURE ALL CONNECTIONS AND END CAPS ARE PROPERLY SEALED WITH A DIELECTRIC GREASE (AVAILABLE AT MOST ELECTRICAL SUPPLIERS) TO PREVENT WATER CORROSION AND/OR ELECTRICAL SHORT CIRCUIT.



IF THE FIXTURE IS EXPOSED TO ENVIRONMENTAL TEMPERATURE CHANGES SUCH AS RELOCATION FROM AN OUTDOOR COLD TO AN INDOOR WARM ENVIRONMENT, DO NOT POWER THE FIXTURE ON IMMEDIATELY. INTERNAL CONDENSATION AS A RESULT OF ENVIRONMENTAL TEMPERATURE CHANGE CAN CAUSE INTERNAL FIXTURE DAMAGE. LEAVE THE FIXTURE POWERED OFF UNTIL IT HAS REACHED ROOM TEMPERATURE BEFORE POWERING ON.

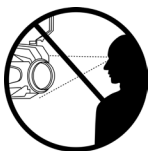

NEVER LOOK DIRECTLY INTO THE LIGHT SOURCE! RETINA INJURY RISK - MAY INDUCE BLINDNESS! SENSITIVE PERSONS MAY SUFFER AN EPILEPTIC SHOCK!

SAFETY GUIDELINES

DO NOT TOUCH the fixture housing during operation. Turn OFF the power and allow approximately 15 minutes for the fixture to cool down before servicing.

DO NOT shake fixture, and avoid brute force when installing and/or operating fixture.

DO NOT operate fixture if the power cord has become frayed, crimped, damaged and/or if any of the power cord connectors are damaged and do not insert into the fixture securely with ease.

NEVER force a power cord connector into the fixture. If the power cord or any of its connectors are damaged, replace it immediately with a new one of the same power rating.

DO NOT block any air ventilation slots; these must remain clean and never blocked. Allow approx. 7.9” (20cm) between fixture and other devices or a wall for proper cooling.

When installing fixture in a suspended environment, always use mounting hardware that is no less than M10 x 25 mm, and always attach an appropriately rated safety cable.

ALWAYS disconnect fixture from main power source before performing any type of service and/or cleaning procedure. Only handle the power cord by the plug end; never pull out the plug by tugging the wire portion of the cord.

During the initial operation of this fixture, a light smoke or smell may emit from the interior of the fixture. This is a normal process and is caused by excess paint in the interior of the casing burning off from the heat associated with the LED and will decrease gradually over time.

Consistent operational breaks will ensure fixture will function properly for many years.

ONLY use the original packaging and materials to transport the fixture in for service.

TRANSPORTATION & HANDLING

POTENTIAL INTERNAL DAMAGE FROM 'TIPPING' FIXTURE DURING TRANSPORT AND HANDLING

Note that not all features listed are available on all fixtures; the following instructions may not apply.

Depending on the model, large format fixtures may contain delicate optics and glass filters. While this product was carefully designed to be roadworthy, it must be handled carefully during transportation. If the fixture contains color flags, before transport, ensure that color flags inside the unit are placed in an OPEN position.

For superior impact protection, some fixtures are shipped in a custom fitted high-density Foam Inlay (FIL). This FIL must be used inside the road-cases for transportation.

DO NOT TIP THE CASE OVER, AND AVOID ALL SHOCKS AND ROUGH HANDLING, ESPECIALLY "TIPPING", THE PRACTICE OF TIPPING THE FIXTURE-CASE OVER TO ITS SIDE AND ONTO A HARD SURFACE. THE CASE MUST RIDE ON ITS WHEELS SO THAT THE FIXTURE-HEAD REMAINS HORIZONTAL DURING TRANSPORTATION.

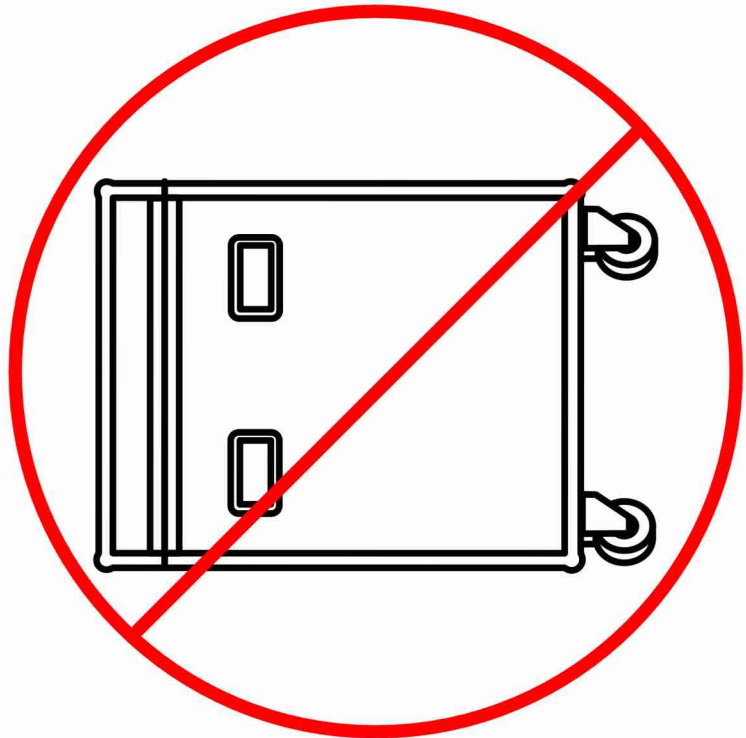
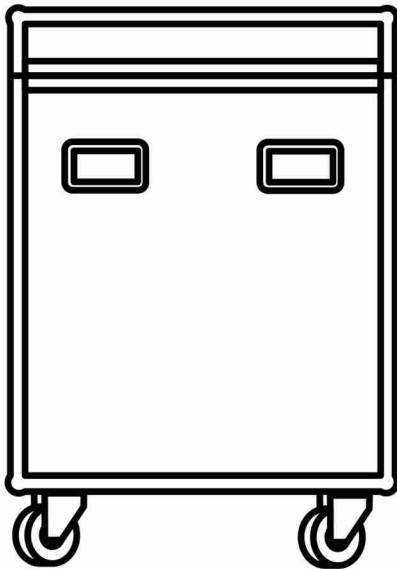

OVERVIEW

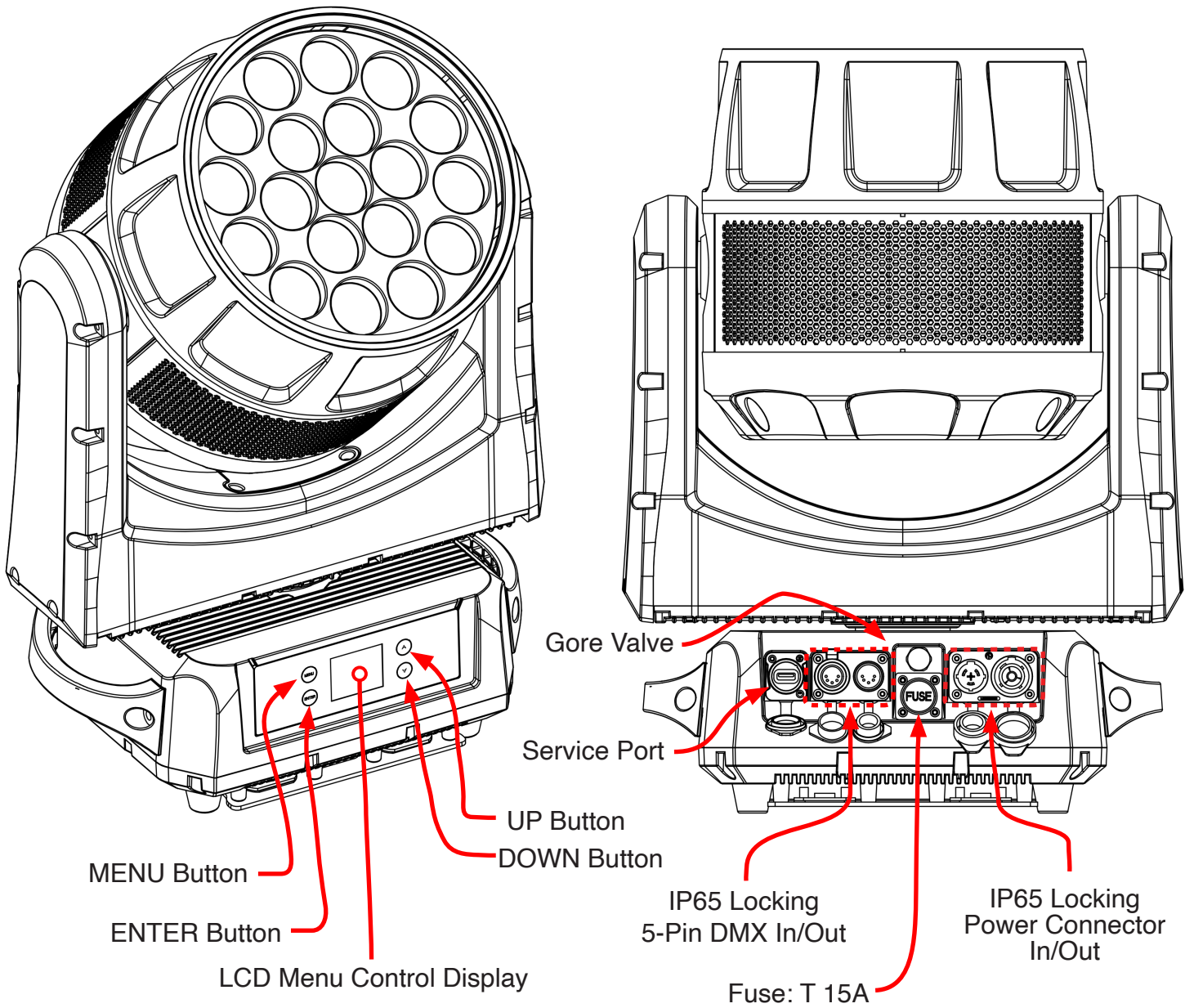

TORQUE SCREWS & IP TESTER

ALL SCREWS MUST BE TIGHTENED WITH A TORQUE DRIVER. All screws are Allen Head screws. Please see below for screw locations, screw quantity and torque settings. The number listed in the “#” column corresponds to the location on the fixture. See the fixture diagram and number on the next page for **SCREW LOCATION** depictions.

#	Screw Locations	Screw Torque Settings
1	Heat Sink to Head Front Cover (x8)	7.5-10.0 In-Lb
2	Sealed Back Cover to Head Back Cover (x4)	7.5-10.0 In-Lb
3	Yoke Arm Cover to Yoke Frame (8 x Each Side = 16 Total)	7.5-10.0 In-Lb
4	Access Cover to Yoke Frame (x4)	7.5-10.0 In-Lb
5	2nd Access Cover to Yoke Frame (x8)	7.5-10.0 In-Lb
6	Power & Data Connector to Base Casting (x10)	6.0-8.5 In-Lb
7	Handle to Base Casting (2 x Each Side = 4 Total)	Fasten by Air Screwdriver
8	Base Bottom Cover to Base Casting (x12)	7.5-10.0 In-Lb
9	Quick Lock Plate to Base Bottom Cover (x16)	7.5-10.0 In-Lb
10	Fixture Feet to Base Bottom (x4)	6.0-8.5 In-Lb

TORQUE DRIVERS (Recommended): UTICA TS-30 (Shown)

ALTERNATIVE DRIVERS:

Proto J6107A
Wiha 28887



CAUTION! DO NOT OVER TORQUE SCREWS AS THIS CAN CAUSE LEAKAGE ISSUES! TO CONFIRM THE IP65 INTEGRITY AFTER MAINTENANCE, TEST THE FIXTURE USING THE ADJ IP TESTER. CONTACT ADJ SERVICE FOR MORE DETAILS.

Hydro Beam X12 IP Testing Parameters			
Vacuum(KPA)	Hold time(S)	Pressure(KPA)	Hold time(S)
-30KPA	60S	13KPA	60S



TORQUE SCREW LOCATIONS

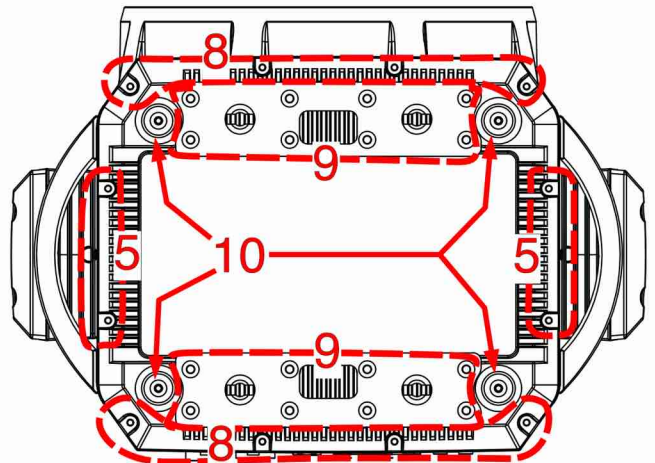
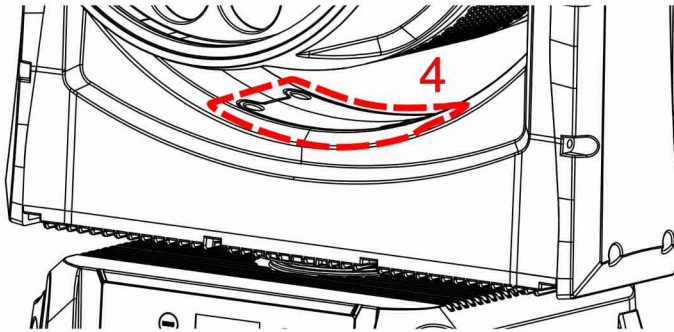
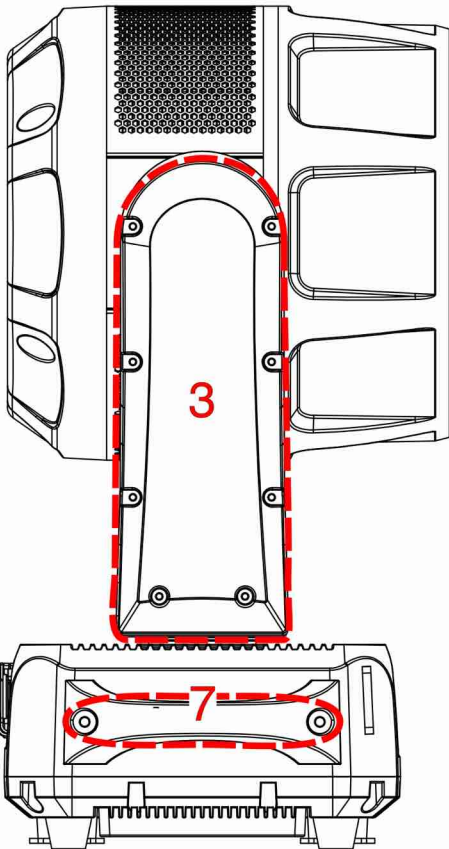
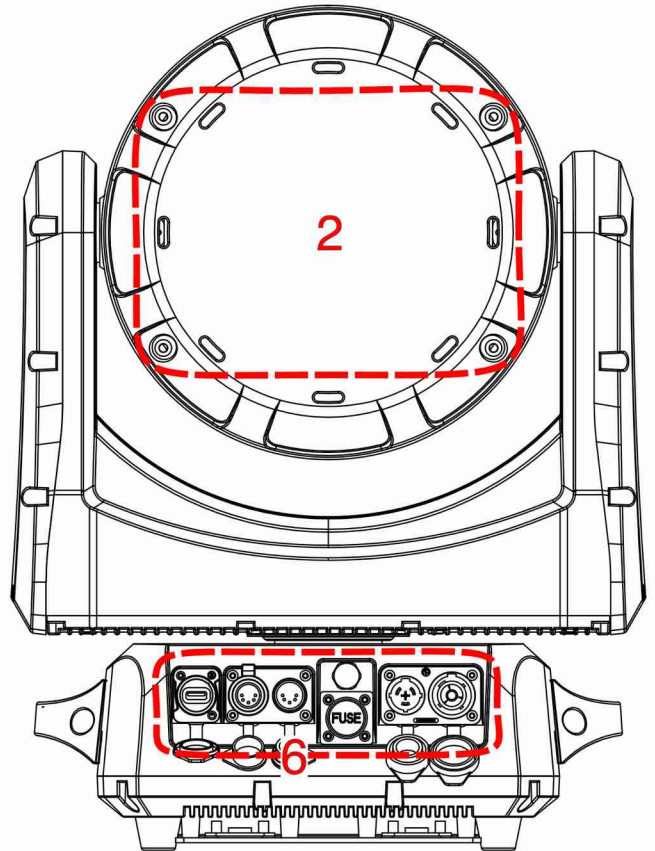
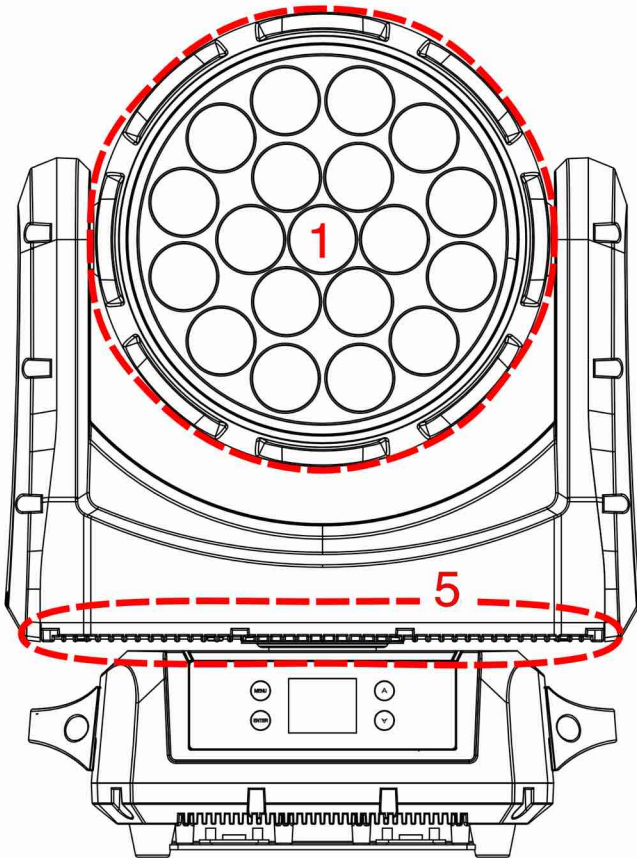

FIXTURE INSTALLATION



FLAMMABLE MATERIAL WARNING

Keep fixture at least 7.9in. (0.2m) away from any flammable materials, decorations, pyrotechnics, etc.



ELECTRICAL CONNECTIONS

A qualified electrician should be used for all electrical connections and/or installations.



MINIMUM DISTANCE TO OBJECTS/SURFACES MUST BE 1.6 FEET (0.5 METERS)



MAXIMUM TEMPERATURE OF EXTERNAL SURFACE 167°F (75°C)

DO NOT INSTALL THE FIXTURE IF YOU ARE NOT QUALIFIED TO DO SO!

Fixture **MUST** be installed following all local, national, and country commercial electrical and construction codes and regulations. Before rigging/mounting the fixture to any metal truss/structure or placing the fixture on any surface, a professional equipment installer **MUST** be consulted to determine if the metal truss/structure or surface is properly certified to safely hold the combined weight of the fixture, clamps, cables, and accessories.

Overhead fixture installation must always be secured with a secondary safety attachment, such as an appropriately rated safety cable that meets all local, national, and country codes and regulations.

Fixture ambient operating temperature range is **-4°F to 104°F. (-20°C to 40°C)** Do not use this fixture outside this temperature range.

Fixture should be installed in areas outside walking paths, seating areas, or away from areas where unauthorized personnel might reach the fixture by hand.

NEVER stand directly below the fixture when rigging, removing, or servicing.

Allow approximately 15-minutes for the fixture to cool down before servicing.

FIXTURE INSTALLATION: OMEGA BRACKET & TRUSS CLAMP

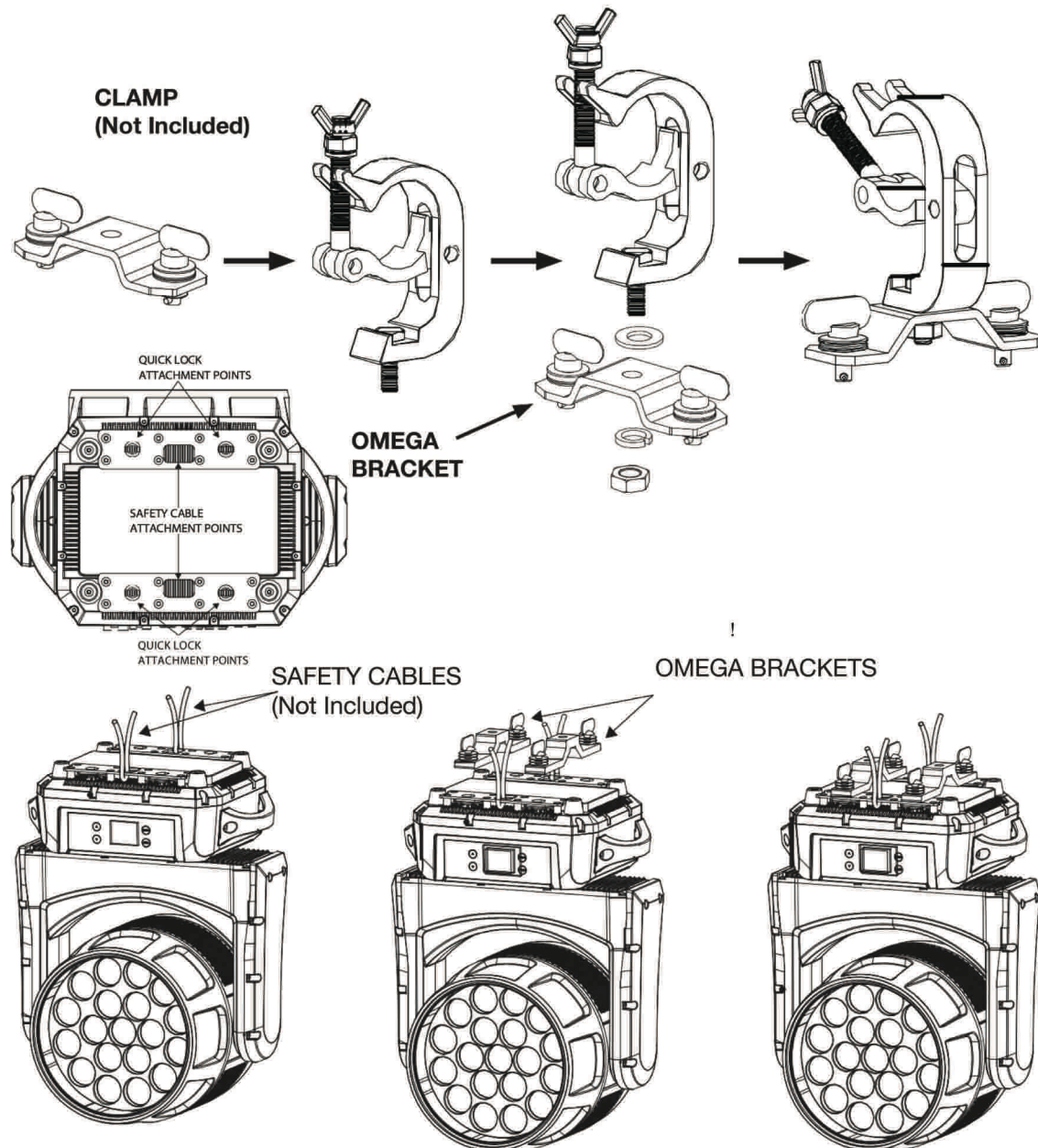

Screw one clamp via an M12 screw and nut into the Omega Bracket. Insert the quick-lock fasteners of the Omega Bracket into the respective holes of the fixture base plate. **NOTE: The clamp must be attached to the Omega Bracket before attaching the bracket to the fixture.** Tighten the quick-lock fasteners fully clockwise. Pull the safety-cable through the openings located on the bottom of the unit and over the trussing system or a safe fixation spot. Insert the end in the carabiner and tighten the safety screw.

NEVER stand directly below the fixture when rigging, removing, or servicing.

Always allow approximately 60 minutes for the fixture to cool down before servicing.

FIXTURE INSTALLATION: TRUSS INSTALLATION

The trussing or area of installation must be able to support at least 10 times the weight without any deformation. The unit must be secured with a secondary safety attachment, such as an appropriately rated safety cable. Never stand directly below the unit when mounting, removing, or servicing the unit.

Overhead mounting requires extensive experience, including calculating working load limits, installation material being used, and periodic safety inspection of all installation material and the unit. If you lack these qualifications, do not attempt the installation yourself.

The installation should be checked by a skilled person once a year.

The Hydro Wash X19 is fully operational in three different mounting positions: hanging upside-down, mounted sideways on trussing, or set on a flat level surface. Always use and install a safety cable as a safety measure to prevent accidental damage and/or injury in the event the clamp fails. Never use the carrying handles to secure the secondary attachment.

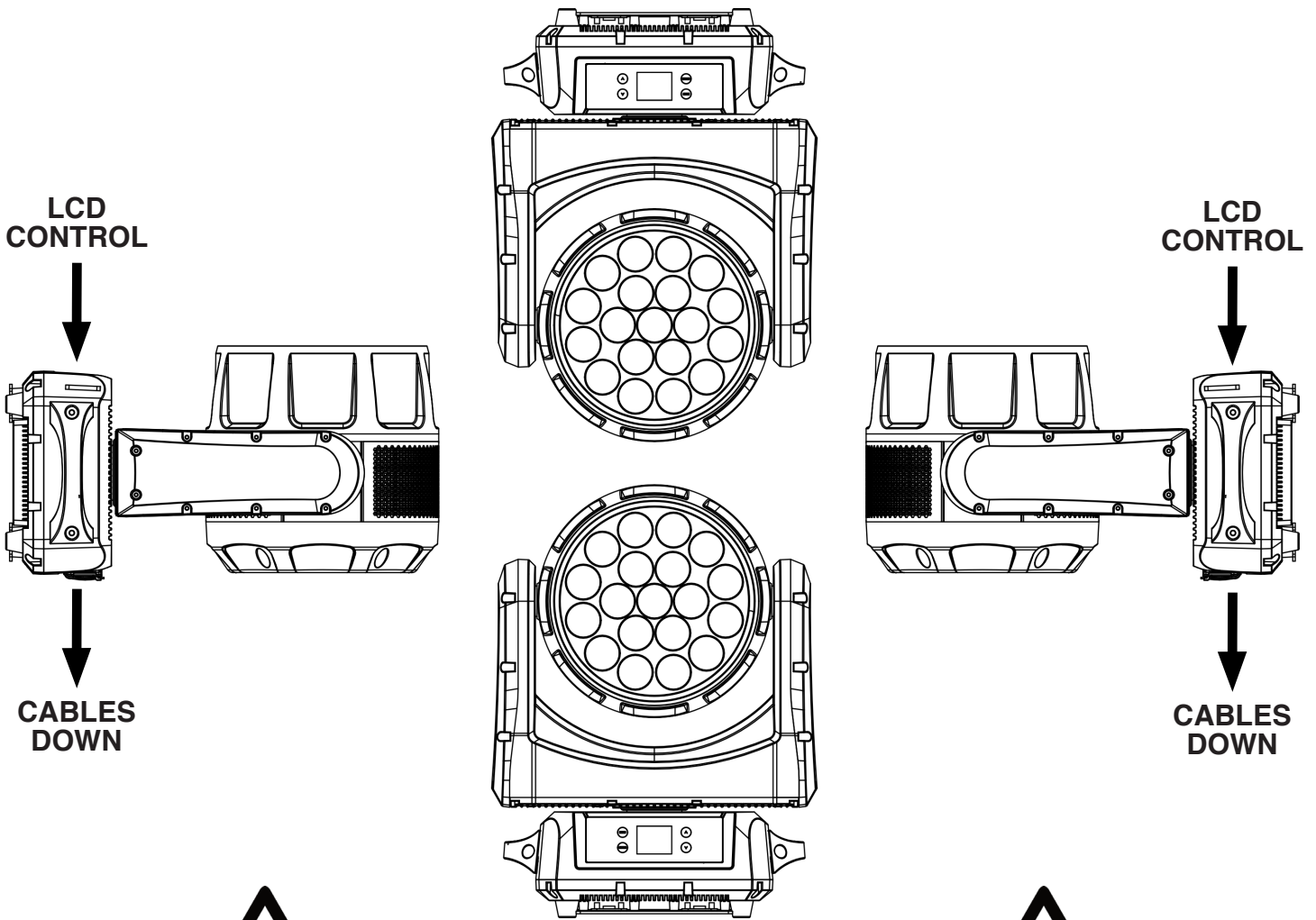

SIDE MOUNTING

TO MAINTAIN IP65 RATING INTEGRITY, FIXTURE MUST BE INSTALLED WITH CABLES FACING THE GROUND AT ALL TIMES. WATER MUST EASILY RUN OFF AND NOT COLLECT AROUND CABLE CONNECTIONS.



SAFETY CABLE

ALWAYS ATTACH A SAFETY CABLE WHENEVER INSTALLING THIS FIXTURE IN A SUSPENDED ENVIRONMENT TO ENSURE THE FIXTURE WILL NOT DROP IF THE CLAMP FAILS.

FIXTURE INSTALLATION: DIRECT LIGHT SOURCE

POTENTIAL INTERNAL FIXTURE DAMAGE FROM EXTERNAL SOURCES OF LIGHT BEAMS

External sources of light beams from direct sunlight, lighting moving head fixtures, and lasers, which are focused directly towards the exterior housing and/or penetrate the front lens opening of ADJ lighting fixtures, can cause severe internal damage including burning to optics, dichroic color filters, glass and metal gobos, prisms, animation wheels, frost filters, iris, shutters, motors, belts, wiring, discharge lamps, and LEDs.

This issue is not specific only to ADJ lighting fixtures, it is a common issue with lighting fixtures from all manufacturers. Although there is no true way to fully prevent this issue from happening, the guidelines below can prevent any potential damage from occurring if followed. Contact ADJ Service for more details.

DO NOT EXPOSE THE FIXTURE AND/OR FRONT LENS OPENING TO LIGHT BEAMS FROM DIRECT SUNLIGHT, OTHER LIGHTING MOVING HEAD FIXTURES, AND LASERS WHILE UNPACKING, INSTALLATION, USE, AND EXTENDED IDLE TIMES OUTDOORS.
DO NOT FOCUS A LIGHT BEAM FROM ONE LIGHTING FIXTURE DIRECTLY TOWARDS ANOTHER.

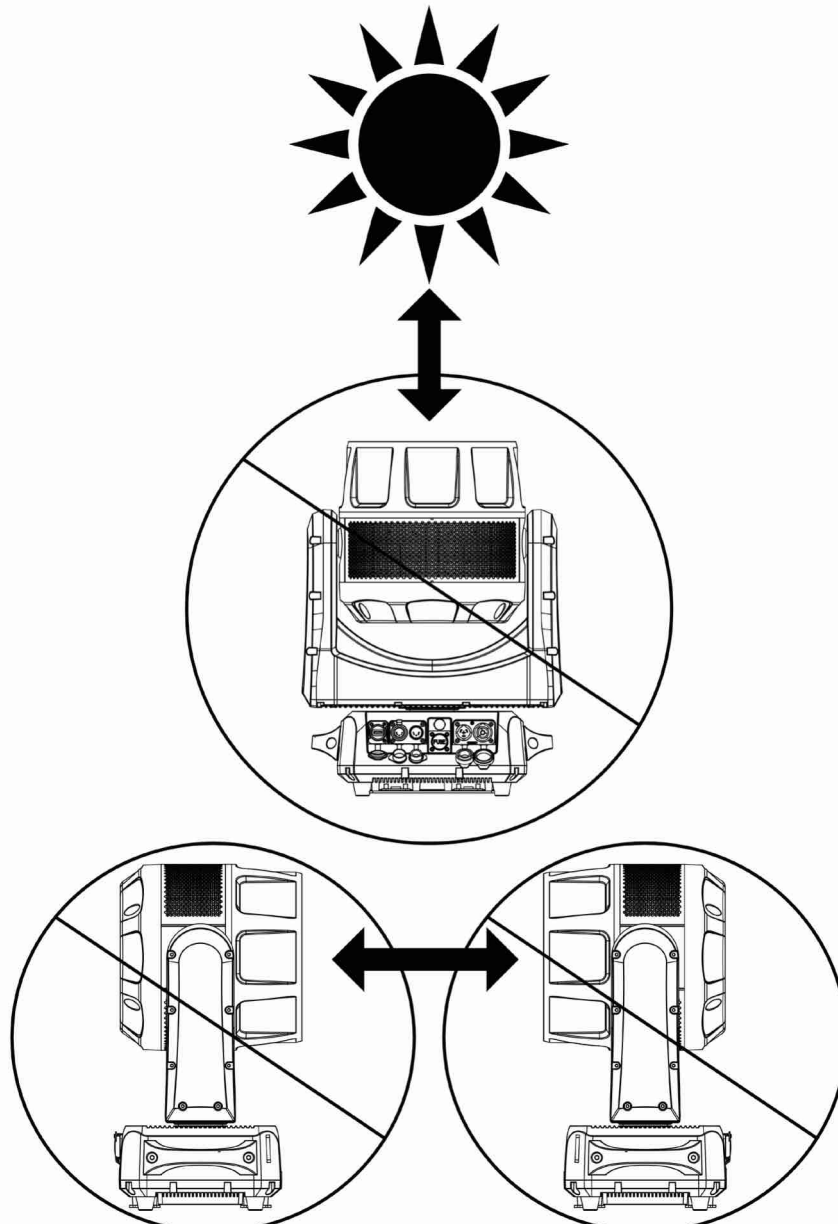

FIXTURE INSTALLATION: CONNECTIONS

ENSURE ALL CONNECTIONS AND END CAPS ARE PROPERLY SEALED WITH A DIELECTRIC GREASE (AVAILABLE AT MOST ELECTRICAL SUPPLIERS) TO PREVENT WATER CORROSION AND/OR ELECTRICAL SHORT CIRCUIT.

TO MAINTAIN IP65 RATING INTEGRITY AND PREVENT WATER FROM ENTERING THE FIXTURE, ALL UNUSED CONNECTION RUBBER CAPS MUST BE SEALED.

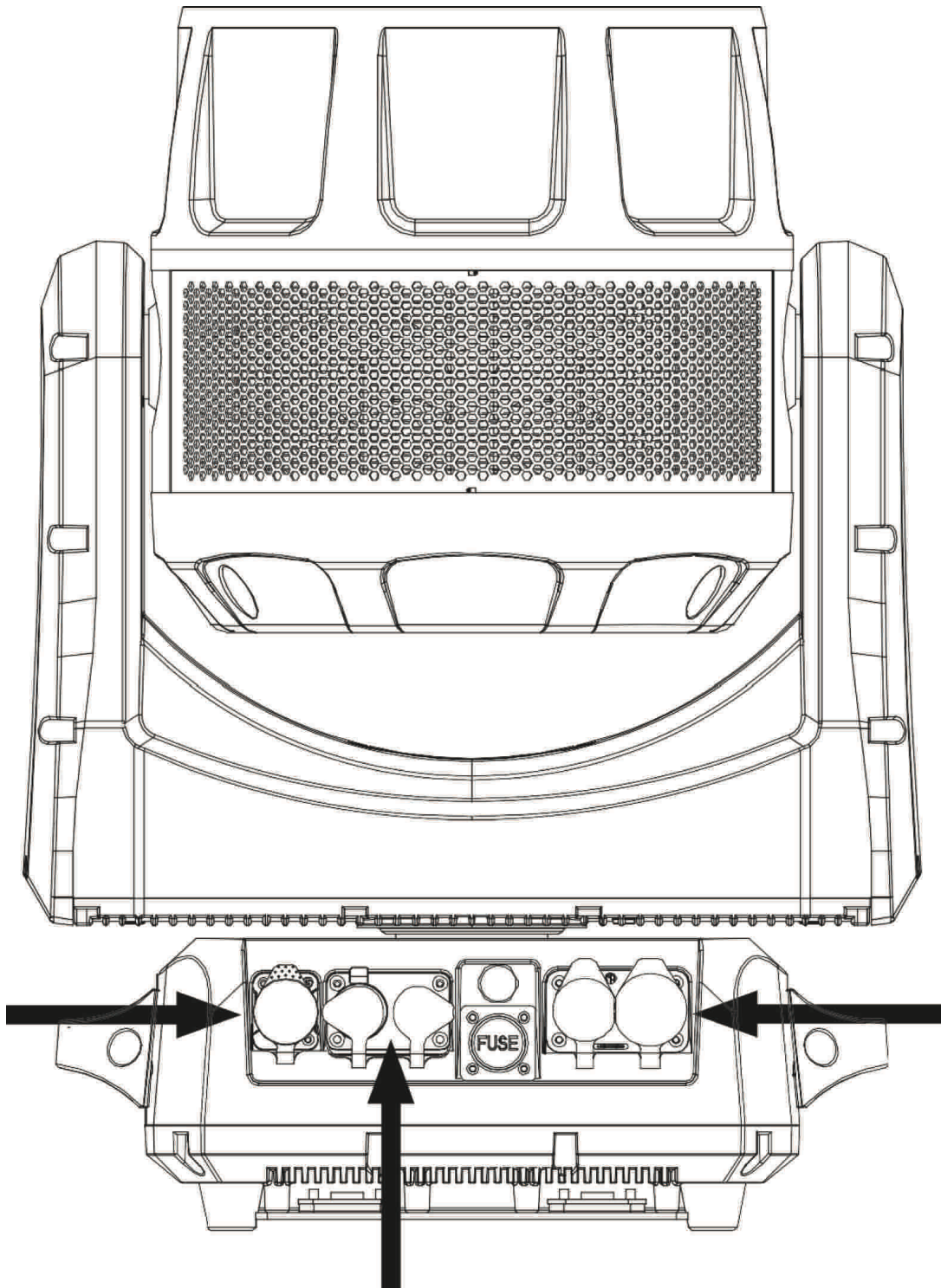

REMOTE DEVICE MANAGEMENT (RDM)

NOTE: In order for RDM to work properly, RDM enabled equipment must be used throughout the entire system, including DMX data splitters and wireless systems.

Remote Device Management (RDM) is a protocol that sits on top of the DMX512 data standard for lighting, allowing the DMX systems of the device to be managed, modified, and monitored remotely (hence, remote device management). This protocol is ideal for fixtures installed in locations that are not easily accessible.

With RDM, the DMX512 system becomes bi-directional, allowing a compatible RDM enabled controller to send out a signal to devices on the wire, as well as allowing the fixture to respond (known as a GET command). The controller can then use it's SET command to modify settings that would typically have to be changed or viewed directly via the unit's display screen, including the DMX Address, DMX Channel Mode, and Temperature Sensors.

FIXTURE RDM INFORMATION:

RDM Code	Device ID	Device Model ID	Personality ID
0x1900	Random	0x04A0	0x01016(16ch), 0x0206(20ch), 0x0306(26ch), 0x0406(30ch), 0x0506(88ch), 0x0606(90ch)

Please be aware that not all RDM devices support all RDM features, and therefore it is important to check beforehand to ensure that the equipment that you are considering includes all of the features that you require.

The following parameters are accessible in RDM on this device:

MANUFACTURER
SOFTWARE VERSION
DMX START ADDRESS
DEVICE MODEL DESCRIPTION
DEVICE LABEL
DMX PERSONALITY
DMX PERSONALITY DESCRIPTION
DEVICE HOURS
RESET DEVICE - WARM RESET
RESET DEVICE - COLD RESET

FAN MODES & LOW NOISE OPERATION

The **Hydro Wash X19** is a high-performance fixture suited for multiple applications. For noise critical environments such as Theater, Opera or Orchestra Halls, it offers various fan operation modes which remove any distraction for the audience and performers. Fan Modes can be changed remotely via the DMX control channel, allowing the fixture to offer high output or whisper silent operation at a moment's notice. All Fan Modes smoothly transition over a brief time, preventing unwanted attraction to the fixture.

Mode	dbA at 1m LED off	dbA at 1m Dimmer 100%
Fan Control - Auto (Default)	39	46
Fan Control - Low	38	40
Fan Control - High	50	59
Low Noise – Studio	34	37
Low Noise – Mute	32	33

Auto (Default)— Fans only run at the speeds needed to keep the LED engine within a safe temperature range and ensures optimal performance of the fixture. If possible, they will turn-off, for example, when the fixture is dimmed to a low intensity. Fans sense the ambient and fixture temperature, and will always try to keep noise levels to a minimum. The fixture output will only reduce when the LED engine cannot be cooled down to its safe operating range due to high ambient temperature.

NOTE: Recommended for daily operation.

High—Fan speeds are increased throughout for the most efficient cooling of the fixture. This mode will increase wear on the fans and should only be utilized in exceptional circumstances. Fans will always run, even if the fixture is dimmed down. Fixture output is kept at 100% unless the LED engine temperature reaches an unsafe temperature at which point the fixture will reduce power carefully to ensure continued safe operation. This mode is only required in very high ambient temperatures when automatic fan speed adjustments are not desired.

Silent—For very critical noise environments, the fixture offers two additional Low Noise Modes for silent operation. The fixture output will be reduced, however due to the extremely high luminous flux the fixture still offers outstanding performance. In Low Noise Modes all parameters of the fixture operate quieter with reduced fan speeds.

Almost all fixture fans are turned off, and only run when necessary. The fixture LED power output is reduced to 50%.

DMX SETUP

DMX-512: DMX is short for Digital Multiplex. This is a universal protocol used as a form of communication between intelligent fixtures and controllers. A DMX controller sends DMX data instructions from the controller to the fixture. DMX data is sent as serial data that travels from fixture to fixture via the DATA “IN” and DATA “OUT” XLR terminals located on all DMX fixtures (most controllers only have a DATA “OUT” terminal).

DMX Linking: DMX is a language allowing all makes and models of different manufacturers to be linked together and operate from a single controller, as long as all fixtures and the controller are DMX compliant. To ensure proper DMX data transmission, try to use the shortest cable path possible when using several DMX fixtures. The order in which fixtures are connected in a DMX line does not influence the DMX addressing. For example, a fixture assigned a DMX address of 1 may be placed anywhere in a DMX line: at the beginning, at the end, or anywhere in the middle. When a fixture is assigned a DMX address of 1, the DMX controller knows to send DATA assigned to address 1 to that unit, no matter where it is located in the DMX chain.

Data Cable (DMX Cable) Requirements (For DMX Operation): The Hydro Wash X19 can be controlled via DMX-512 protocol. Your unit and your DMX controller require a 5-pin XLR connector for data input and data output. We recommend IP65 rated DMX cables to secure the IP65 connections, such as our Accu Cable STR Series Data Cables. If you are making your own cables, be sure to use standard 110-120 Ohm shielded cable (This cable may be purchased at almost all pro lighting stores). Your cables should be made with an IP65 rated male 5-pin XLR type connector on one end of the cable and an IP65 rated female 5-pin XLR type connector on the other. Also remember that DMX cable must be daisy chained and cannot be split.

Special Note: Line Termination. When longer runs of cable are used, you may need to use a terminator on the last unit to avoid erratic behavior. A terminator is a 110-120 ohm 1/4 watt resistor which is connected between pins 2 and 3 of a male XLR connector (DATA + and DATA -). This unit is inserted in the female XLR connector of the last unit in your daisy chain to terminate the line. Using a cable terminator (ADJ part number Z-DMX/T) will decrease the possibilities of erratic behavior.

TO MAINTAIN IP65 RATING INTEGRITY AND PREVENT WATER FROM ENTERING THE FIXTURE, ALL UNUSED CONNECTION RUBBER CAPS MUST BE SEALED, AND ONLY IP65 RATED POWER AND DATA CABLES MUST BE USED.

SYSTEM MENU

The fixture includes an easy to navigate system menu control panel where all necessary settings and adjustments are made. (See image below) During normal operation, pressing the **MENU** button once will access the fixture's main menu. Once in the main menu, you can navigate through the different functions and access the sub-menus with the **UP** and **DOWN** buttons. When you reach a field that requires adjusting, press the **ENTER** button to access that field and use the **UP** and **DOWN** buttons to adjust the field. Pressing the **ENTER** button once more will confirm your setting. You may exit the main menu at any time without making any adjustments by pressing the **MENU** button.

SYSTEM LOCK/UNLOCK: When the display lock function is activated, the display and system menu will lock after 10 seconds of inactivity. To **UNLOCK** the display, press and **HOLD** the **MENU** button for 10+ seconds. A timer will appear at the bottom right of the display indicating the passing seconds from 0-9. Once the timer reaches 9 seconds, the display will unlock to allow access to the system menu.

DO NOT RELEASE THE MENU BUTTON UNTIL THE DISPLAY IS UNLOCKED.

If the **MENU** button is released before the timer reaches 9 seconds and/or the display is unlocked, the display will not unlock and the time will be reset.

NOTE: The timer will not appear in the display if the lock function is disabled.

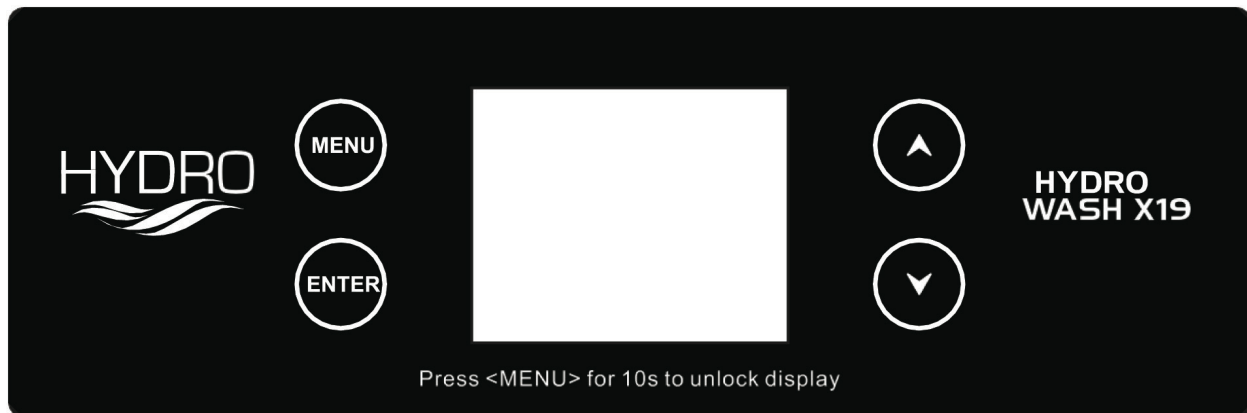

SOFTWARE UPDATES

This fixture can be updated via the service port. Please contact ADJ Support for further details.

ADJ SERVICE USA - Monday - Friday 8:00am to 4:30pm PST
323-582-2650 | Fax: 323-832-2941 | support@adj.com

ADJ SERVICE EUROPE - Monday - Friday 08:30 to 17:00 CET
+31 45 546 85 60 | Fax: +31 45 546 85 96 | support@adj.eu

SYSTEM MENU

MAIN MENU	OPTIONS / VALUES (Default Settings in BOLD)		DESCRIPTION
DMX SETTINGS	DMX Address	001 - 512	
	DMX Channel Mode	16 Ch	
		20 Ch	
		26 Ch	
		30 Ch	
		88 Ch	
		90 Ch	
	No DMX Status	Hold Last	
		Blackout	
		Int Programs	
Manual			
ETHERNET SETTINGS	Protocol	ArtNet	Has priority over DMX and E-Fly when enabled
		sACN	
		KlingNet	
		Disable	
	IP Address	2.1.1.1	
	Net Mask	255.0.0.0	
	ArtNet Universe	0 - 32, 767	
	sACN Settings	sACN Universe	00001 - 32000
sACN Priority		0 - 255	
Lock Ethernet Setting	On / Off		
PERSONALITY	Select Signal	DMX	Yes / No
		WiFly	Yes / No
		WiFly and DMX Out	Yes / No
	Status Settings	Pan Invert	On / Off
		Tilt Invert	On / Off
		P/T Feedback	On / Off
		P/T Speed	Speed 1
			Speed 2
		Hibernation	Off 01M - 99M
	WiFly Settings	Set WiFly Channel	0 - 14
		Enable WiFly / Disable WiFly	
	Fan Settings	Head	Auto
			High
			Silent (Low)
		Base	Auto
			High Silent (Low)
	Dim Modes	Standard	
		Stage	
		TV	
		Architectural	
Theatre			
Stage2			
Dim Speed		0.1s - 10s	

SYSTEM MENU

MAIN MENU	OPTIONS / VALUES (Default Settings in BOLD)		DESCRIPTION	
PERSONALITY	LED Refresh Rate	900 Hz		
		1000 Hz		
		1100 Hz		
		1200 Hz		
		1300 Hz		
		1400 Hz		
		1500 Hz		
		2500 Hz		
		4000 Hz		
		5000 Hz		
		6000 Hz		
		10,000 Hz		
		15,000 Hz		
	Gamma	1.0		
		2.0		
		2.2		
		2.4		
		2.6		
		2.8		
	Reset Motors	Reset All Motor	Yes / No	
		Pan/Tilt Reset	Yes / No	
		Zoom Reset	Yes / No	
	Display	Intensity	1 - 10	
		Display Invert	Yes / No	
		Screen Saver Delay	Off - 10m	
		Display Lock	On / Off	
	Service	Passcode = 050	Calibration	Pan: -128 - 127
				Tilt: -128 - 127
Red: 125 - 255				
Green: 125 - 255				
...				
White19: 125 - 255				
Zoom -128 - 127				
	Factory Restore	Yes / No		

SYSTEM MENU

MAIN MENU	OPTIONS / VALUES (Default Settings in BOLD)		DESCRIPTION	
MANUAL CONTROL	Mode 1	Pan	000 - 255	
		Tilt	000 - 255	
		Color	000 - 255	
		Red1	000 - 255	
		
		White 19	000 - 255	
		Color Macros	000 - 255	
		Shutter	000 - 255	
		Dimmer	000 - 255	
		Zoom (Narrow to Wide)	000 - 255	
		Special Function	000 - 255	
	Mode 2	Pan	000 - 255	
		Tilt	000 - 255	
		Color	000 - 255	
		All Red	000 - 255	
		All Green	000 - 255	
		All Blue	000 - 255	
		All White	000 - 255	
		Color Macros	000 - 255	
		Shutter	000 - 255	
		Dimmer	000 - 255	
		Zoom (Narrow to Wide)	000 - 255	
INTERNAL PROGRAMS	Program 0	Speed	000 - 255	
		Fade	000 - 255	
	Program 1	Speed	000 - 255	
		Fade	000 - 255	
	Program 2	Speed	000 - 255	
		Fade	000 - 255	
	Program 3	Speed	000 - 255	
		Fade	000 - 255	
Program 4	Speed	000 - 255		
	Fade	000 - 255		
TARGET MODE	Mode 0			
	Mode 1			
	Mode 2			
	Mode 3			
	Mode 4			

SYSTEM MENU

MAIN MENU	OPTIONS / VALUES (Default Settings in BOLD)		DESCRIPTION		
INFORMATION	Fixture Life Time	Power On Time	Total hours fixture has been powered on. Cannot be reset.		
		P-On Time-R	Current hours that fixture has been powered on. Resettable back to 0.		
		P-On Time-Reset	Select to reset power on time. Passcode = 050.		
	Total LED Time	LED On Time	Total hours LED has been powered on. Cannot be reset.		
		LED On Time-R	Current hours that LED has been powered on. Resettable back to 0.		
		LED On Time Reset	Select to reset current LED on time. Passcode = 050		
	Fixture Temps	LEDs	Current (F / C)		
			Max Resettable (F / C)	Current max temp reading since last reset	
			Max Not Resettable (F / C)	All time max temp reading. Cannot be reset	
		Head	Current (F / C)		
			Max Resettable (F / C)	Current max temp reading since last reset	
			Max Not Resettable F / C)	All time max temp reading. Cannot be reset	
		Base	Current (F / C)		
			Max Resettable (F / C)	Current max temp reading since last reset	
			Max Not Resettable (F / C)	All time max temp reading. Cannot be reset	
			Reset LED Temp	Yes / No	
			Reset Head Temp	Yes / No	
			Reset Base Temp	Yes / No	
	Humidity	Head / Base			
	Fan Info (RPM)	LED Fan 1	xxxx		
		LED Fan 2	xxxx		
		Head Fan 1	xxxx		
		Head Fan 2	xxxx		
		Head Fan 3	xxxx		
		Arm Fan 1	xxxx		
		Arm Fan 2	xxxx		
	DMX Values	Pan			
Tilt					
...					
Zoom (Narrow to Wide)					
Error Logs	Fixture Errors				
	Reset Error Log	Yes / No	Passcode = 050		
Max Temp LED On	32-169°F, 90°F (0-76°C, 32°C)				
High Temp Off	170°F, 90°F (77°C, 32°C)				
Software Version	x.xx				

***Note: DMX Values settings depend on which DMX Channel Mode has been selected.**

SYSTEM MENU

DMX SETTINGS - The submenus listed under DMX SETTINGS are as follows: DMX Address, DMX Channel Mode, and No DMX Status.

- **DMX ADDRESS** - In this submenu you can find and set your desired DMX address.
- **DMX CHANNEL MODE** - In this submenu you can find and set your desired DMX channel mode.
- **NO DMX STATUS** - This submenu setting determines how the device will behave in the event that the DMX signal is lost or interrupted. The operating mode chosen in this submenu is the running mode the fixture will go into when the DMX signal is lost. Listed below are the 4 modes.
 - **Hold Last** - This setting will have the fixture stay in the last DMX setup.
 - **Blackout** - This setting will have the fixture automatically go into stand by mode.
 - **Int Programs** - This setting will have the fixture default to the last program selected in the Internal Programs system menu.
 - **Manual** - This setting will go into the current manual control set up. See MANUAL CONTROL.

ETHERNET SETTINGS – The submenus listed under ETHERNET SETTINGS are as follows: Protocol, IP Address, Net Mask, Artnet Universe, sACN Settings, and Lock Ethernet Settings.

- **Protocol** – Allows the user to select from Artnet, sACN, or KlingNet as the communications protocol to be used. This may also be disabled for manual control.
- **IP Address** – Shows the IP address of the unit, and allows the user to assign a custom IP address if desired.
- **Net Mask** – Shows the netmask of the unit.
- **Artnet Universe** – Displays the currently-assigned Artnet Universe value, and allows the user to define a custom value, if desired.
- **sACN Settings** – Displays currently-assigned values for the sACN Universe and sACN Priority, and allows the user to define custom values for both parameters, if desired.
- **Lock Ethernet Setting** – Locks or permits changes to Ethernet Settings.

PERSONALITY - The submenus listed under PERSONALITY are as follows: Select Signal, Status Settings, WiFly Settings, Fan Settings, Dim Modes, LED Refresh Rate, Gamma Setting, Reset Motors, Display, and Service.

- **SELECT SIGNAL** - In this submenu you can select your desired DMX control mode:
 - **DMX** - Control the unit via DMX cable connection.
 - **WiFly** - Control the unit via WiFly.
 - **WiFly and DMX Out** - Control the unit via WiFly connection. The DMX signal is sent to the next unit via DMX cable.
- **STATUS SETTINGS** - In this submenu you are able to access and adjust/change: Pan Invert, Tilt Invert, P./T. Feedback, P./T. Speed, and Hibernation.
- **WIFLY SETTINGS** - In this submenu you are able to access and adjust/change: WiFly Channel setting and Enable/Disable WiFly.
- **FAN SETTINGS** - In this submenu you are able to select your desired fan speed settings for both the head and base fans.
- **DIM MODES** - In this submenu you are able to select your desired dimmer mode and adjust the dimming speed time. See section pertaining to the Dimmer Curve Charts.
- **LED REFRESH RATE** - In this submenu you are able to select your desired LED refresh rate.
- **GAMMA** - In this submenu you are able to select your desired gamma setting.
- **RESET MOTORS** - In this submenu you are able to reset selected motors.
- **DISPLAY** - In this submenu you are able to access and adjust/change the backlight intensity, display inversion, screen saver display time, and display lock function.
- **SERVICE** - In this submenu you are able to access the calibration adjustment, software update, and restore the factory settings.

SYSTEM MENU

MANUAL CONTROL - This menu is for manual testing and manual control. Under MANUAL CONTROL the fixture has two control modes; "MODE 1" and "MODE 2".

NOTE: NO DMX STATUS must be set to "Manual" when using Manual Control.

INTERNAL PROGRAMS - This menu allows you to select 1 of 4 internal programs to run. Program speed and fade speed are adjustable. The selected program will also run when "Int Program" is selected under the "NO DMX STATUS" setting.

TARGET MODE - Target mode is a pan/tilt control that restricts the movement to a certain pre-defined degree. See the **Target Mode** section of this manual for detailed information.

INFORMATION - The submenus listed under INFORMATION are as follows: Fixture Life Time, Total LED Time, Fixture Temps, Humidity, Fan Info. (RPM), DMX Values, Error Logs, Max Temp LED ON, High Temp LED OFF, and Software Version.

- **FIXTURE LIFE TIME**

- **Power On Time** - The TOTAL power ON running time of the unit is displayed. This time CANNOT be reset.
- **P-On Time-R** - The CURRENT power ON running time of the unit is displayed. This running time may not be the same as the total power ON running time displayed under "Power On Time". This time CAN be reset. NOTE: The displayed time represents the current power ON time since the last reset.
- **P-On Time Reset** - Reset the CURRENT power ON running time that is displayed under "P-On Time-R".

- **TOTAL LED TIME**

- **LED On Time** - The TOTAL LED ON time is displayed. This total LED ON time CANNOT be reset. NOTE: The displayed time represents the TOTAL LED ON time.
- **LED On Time-R** - The CURRENT LED ON running time is displayed. This running time may not be the same as the total LED ON time displayed under "LED On Time". This total LED ON time CAN be reset. NOTE: The displayed time represents the CURRENT LED ON time since the last reset.
- **LED On Time Reset** - With this function you can reset the CURRENT LED ON time that is displayed under "LED On Time-R".

- **FIXTURE TEMPS**

- **LEDs**

- **Current** - Current temperature of the LED's is displayed.
- **Max Resettable** - Maximum LED temperature that has been recorded, before reset and after reset. (Resettable)
- **Max Not Resettable** - Overall maximum LED temperature that has been recorded. (Not Resettable)

- **Head**

- **Current** - Current temperature of the head is displayed.
- **Max Resettable** - Maximum base temperature that has been recorded, before reset and after reset. (Resettable)
- **Max Not Resettable** - Overall maximum moving head temperature that has been recorded. (Not Resettable)

- **Base**

- **Current** - Current temperature of the base is displayed.
- **Max Resettable** - Maximum base temperature that has been recorded, before reset and after reset. (Resettable)
- **Max Not Resettable** - Overall maximum moving base temperature that has been recorded. (Not Resettable)
- **Reset LED Temp** - Reset the LED temperature reading.
- **Reset head Temp** - Reset the head temperature reading.
- **Reset Base Temp** - Reset the base temperature reading.

- **FAN INFO. (RPM)** - In this submenu the current LED, base, and arm fan speed will be displayed.

- **DMX VALUES** - Displays the DMX values of any DMX channel that is currently in use.

NOTE: DMX value options depend on the current DMX channel mode setting.

- **ERROR LOGS** - In this submenu you are able to check any unit errors as well as clear the error log.

- **MAX TEMP LED ON** - In this submenu you are able to check the normal operating temperatures as well as the current temperature of the fixture.

- **HIGH TEMP LED OFF** - In this submenu you are able to check the normal operating temperatures as well as the current temperature of the fixture.

- **SOFTWARE VERSION** - Current software version is displayed.

WIFLY CONTROL



BEFORE SETTING THE WIRELESS CHANNEL ON ANY WIFLY FIXTURE, MAKE SURE THE SOURCE WIFLY WIRELESS DMX TRANSCEIVER DEVICE IS OFF.

With this feature you are able to control the unit with DMX without the use of XLR cables. Your DMX controller must be connected to a ADJ WiFly Transceiver to use this function. Effective range is up to 2500 feet/760 meters (open line of sight).

1. Ensure the source WiFly wireless DMX Transceiver device is powered OFF.
2. Power ON the fixture and using the control panel scroll to the PERSONALITY menu and press ENTER. Use the UP and DOWN buttons to highlight the WIFLY SETTINGS submenu and press ENTER.
3. Using the UP and DOWN buttons, highlight ENABLE/DISABLE WIFLY. Press the ENTER button to toggle between ENABLE & DISABLE. Press ENTER so that “ENABLE” is displayed.
4. Next highlight SET WIFLY CHANNEL and press ENTER. Use the UP and DOWN buttons to find your desired WiFly address and press ENTER to confirm.

NOTE: Erratic fixture movement may occur if other WiFly wireless DMX products are in use in the same area and are using the same WiFly wireless channel. When WiFly is enabled, the fixture may immediately start to respond to the DMX wireless signal from another WiFly wireless DMX Transceiver. Make sure to know what WiFly wireless channels are being used in the area where the fixture is being used.

ADJ WIFLY WIRELESS TRANSCEIVER only has 0-14 wireless channels, NO CH 15.

5. Set your desired DMX address in the DMX ADDRESS submenu of the DMX SETTINGS main system menu. Set your desired DMX channel mode in the DMX CHANNEL MODE submenu of the DMX SETTINGS main system menu.
6. Repeat this process for all WiFly compatible fixtures in the WiFly wireless network, making sure all fixtures are assigned the same WiFly wireless channel.
7. After all fixtures in the WiFly wireless network have been set to the same WiFly wireless channel and powered ON, power ON the source WiFly DMX Transceiver device.
8. Test all fixtures connected to the WiFly wireless network to confirm proper functionality.

WIFLY CONTROL

WIRELESS WIFLY INSTALLATION LOCATION GUIDELINES

For best results, position the fixture so that the display screen is oriented in the direction of the transmitter device or remote.

Wireless DMX signal can penetrate walls, glass, metal, and most objects. However, there are many factors that can affect and/or interrupt the wireless DMX signal, one of which is people. Therefore, it is highly recommended to position the wireless antenna a minimum of 9.8 ft. (3m) above audiences and/or above ground level. Careful planning and testing of the selected installation location is critical to ensure optimum and reliable wireless DMX operation.

**9.8 ft (3m)
Above Ground**

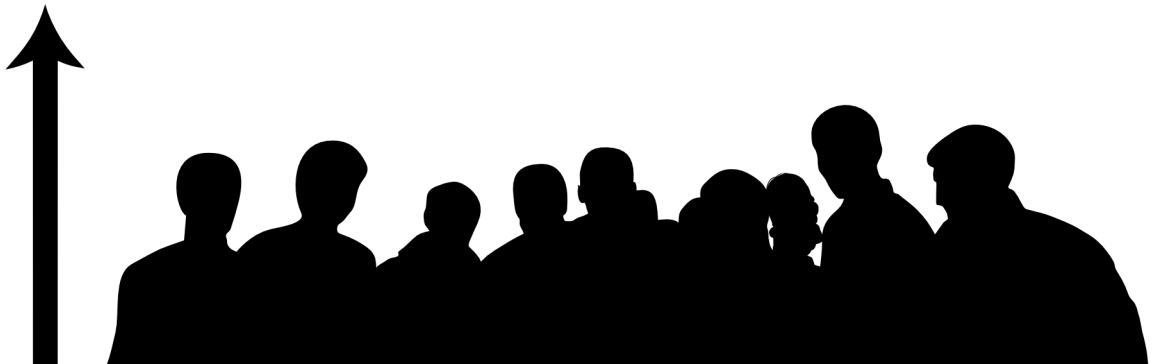

TARGET MODES

This fixture features a Target Mode function that limits operation to a restricted range of movement. Target Mode can be activated and selected using the Target Mode Menu in the main System Menu. Movement ranges of each Target Mode are illustrated in the images below.

TARGET MODE 0:

Mode 0 Tilt Movement Range=230°

Mode 0 Pan Movement Range=540°

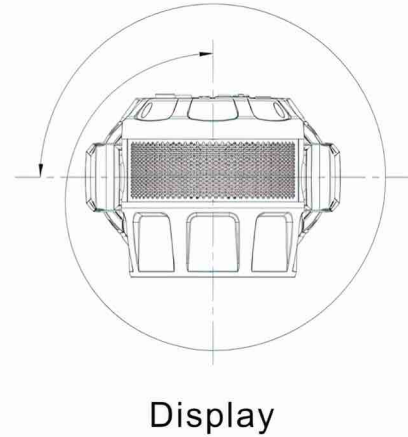
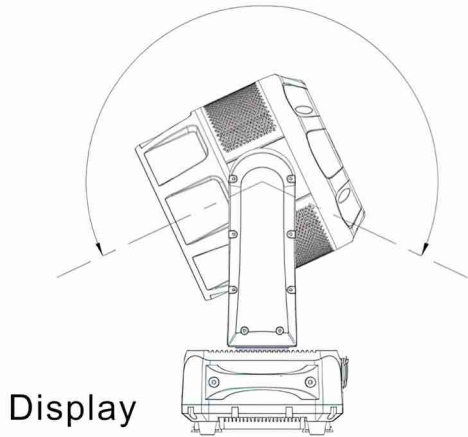

TARGET MODE 1:

Mode 1 Tilt Movement Range=115°

Mode 1 Pan Movement Range=90°

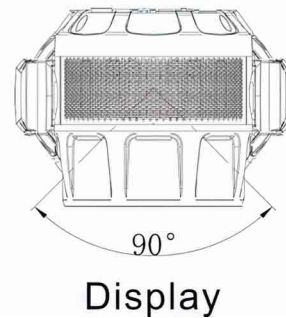
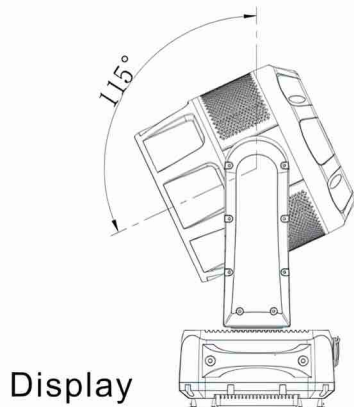

TARGET MODE 2:

Mode 2 Tilt Movement Range=115°

Mode 2 Pan Movement Range=90°

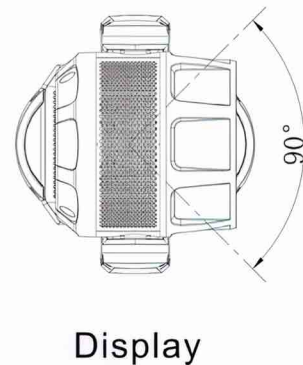
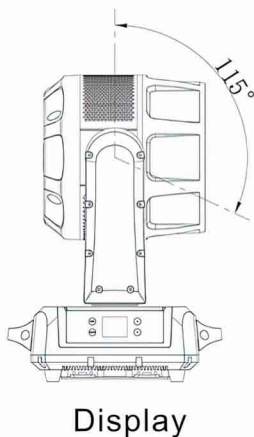

TARGET MODES

TARGET MODE 3:

Mode 3 Tilt Movement Range=115°

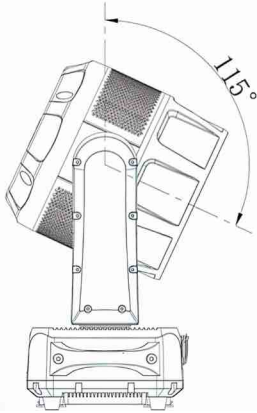

Mode 3 Pan Movement Range=90°

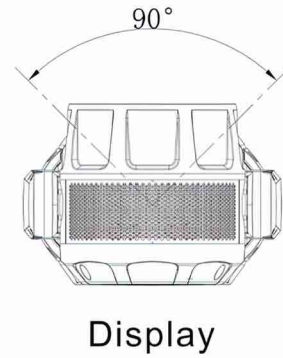

TARGET MODE 4:

Mode 4 Tilt Movement Range=115°

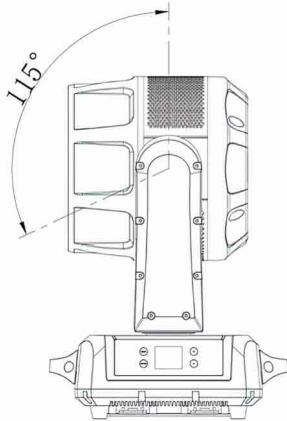

Mode 4 Pan Movement Range=90°

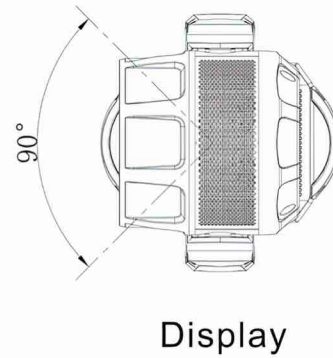

DIMMER CURVE CHART

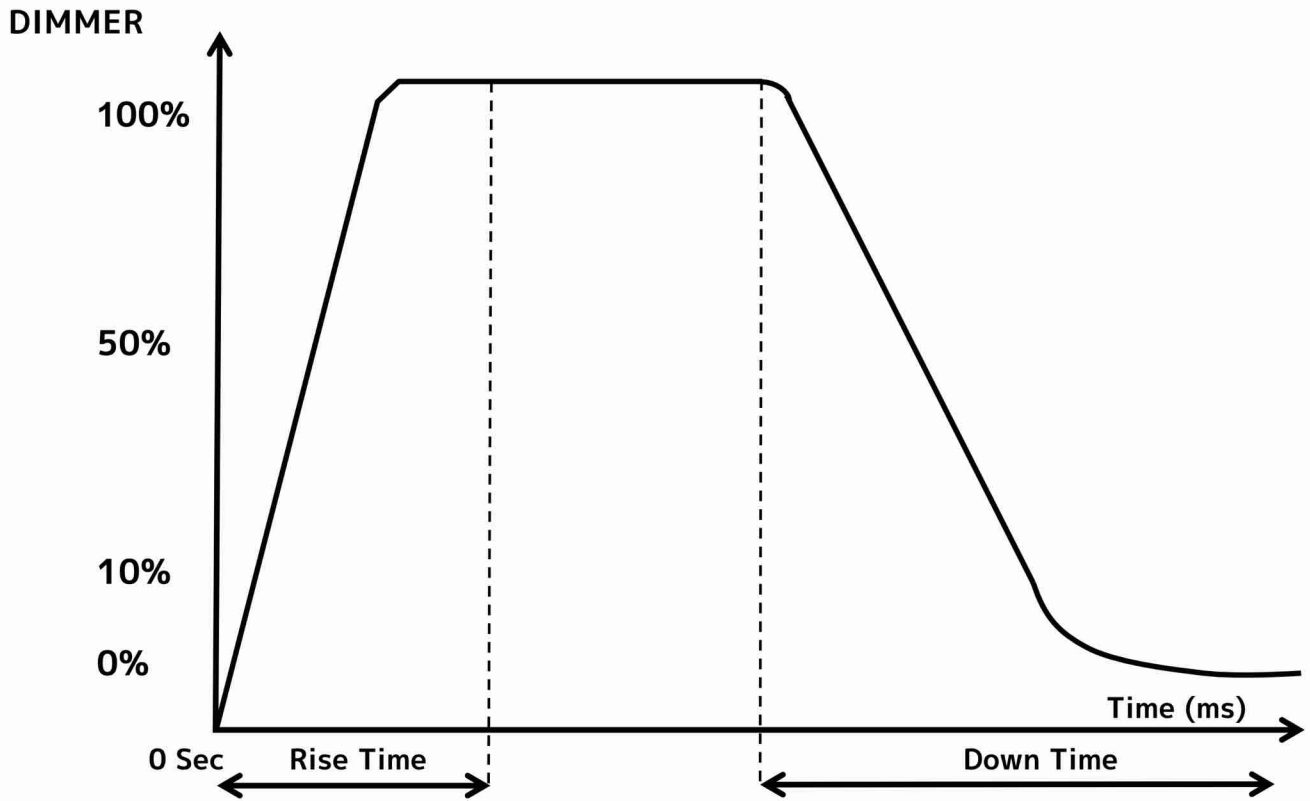

Dimming Curve Ramp Effect	0 sec Fade Time		1 sec Fade Time	
	Rise Time (ms)	Down Time (ms)	Rise Time (ms)	Down Time (ms)
Standard (default)	0	0	0	0
Stage	780	1100	1540	1660
TV	1180	1520	1860	1940
Architectural	1380	1730	2040	2120
Theatre	1580	1940	2230	2280

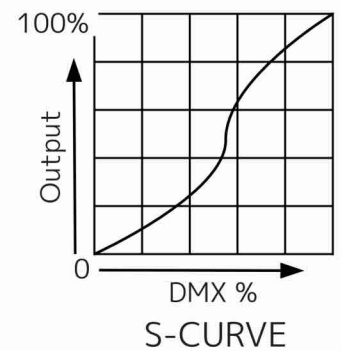
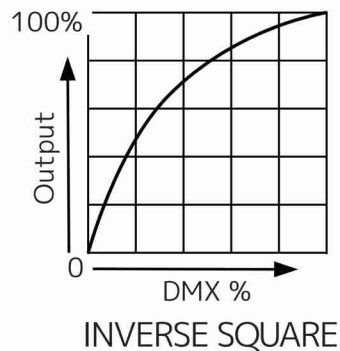
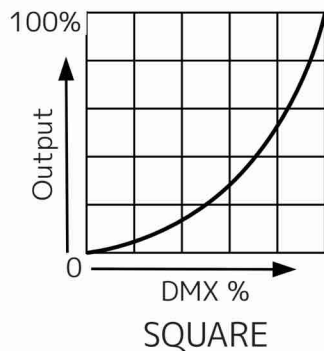
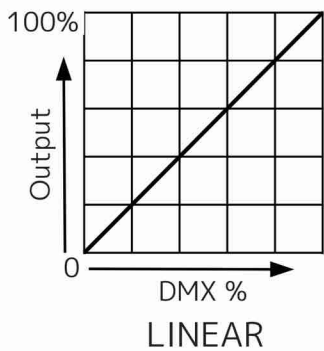

DMX ADDRESSING

All fixtures should be given a DMX starting address when using a DMX controller, so the correct fixture responds to the correct control signal. This digital starting address is the channel number from which the fixture starts to “listen” to the digital control signal sent out from the DMX controller. The assignment of this starting DMX address is achieved by setting the correct DMX address on the digital control display on the fixture.

You can set the same starting address for all fixtures or a group of fixtures, or set different addresses for each individual fixture. Setting all fixtures to the same DMX address will cause all fixtures to react in the same way. In other words, changing the settings of one channel will affect all the fixtures simultaneously.

If you set each fixture to a different DMX address, each unit will start to “listen” to the channel number you have set, based on the quantity of DMX channels of each fixture. That means changing the settings of one channel will only affect the selected fixture.

For example, when operating this device in 16 Channel Mode, you should set the starting DMX address of the first unit to 1, the second unit to 17 (1 + 16), the third unit to 33 (1 + 16 + 16), and so on.

Channel Mode	Unit 1 Address	Unit 2 Address	Unit 3 Address	Unit 4 Address
16 Channels	1	17	33	49
20 Channels	1	21	41	61
26 Channels	1	27	53	79
30 Channels	1	31	61	91
88 Channels	1	89	177	265
90 Channels	1	91	181	271

DMX TRAITS: CHANNEL FUNCTIONS & VALUES

CHANNEL						DMX VALUES	FUNCTION
16CH	20CH	26CH	30CH	88CH	90CH		
1	1	1	1	1	1	000 - 255	Pan , 0% to 100%
2	2	2	2	2	2	000 - 255	Pan Fine , 0% to 100%
3	3	3	3	3	3	000 - 255	Tilt , 0% to 100%
4	4	4	4	4	4	000 - 255	Tilt Fine , 0% to 100%
		5	5		5		Color
						000 - 002	Open
						003 - 004	Color 1
						005 - 006	Color 2
						007 - 008	Color 3
						009 - 010	Color 4
						011 - 012	Color 5
						013 - 014	Color 6
						015 - 016	Color 7
						017 - 018	Color 8
						019 - 021	Color 9
						022 - 023	Color 10
						024 - 025	Color 11
						026 - 027	Color 12
						028 - 029	Color 13
						030 - 031	Color 14
						032 - 033	Color 15
						034 - 035	Color 16
						036 - 037	Color 17
						038 - 039	Color 18
						040 - 042	Color 19
						043 - 044	Color 20
						045 - 046	Color 21
						047 - 048	Color 22
						049 - 050	Color 23
						051 - 052	Color 24
						053 - 054	Color 25
						055 - 056	Color 26
057 - 058	Color 27						
069 - 060	Color 28						
061 - 063	Color 29						
064 - 127	Index						
128 - 189	Clockwise rotation, fast to slow						
190 - 193	Stop						
194 - 255	Counter-clockwise rotation, slow to fast						

DMX TRAITS: CHANNEL FUNCTIONS & VALUES

CHANNEL						DMX VALUES	FUNCTION
16CH	20CH	26CH	30CH	88CH	90CH		
		6	6		6	000 - 255	Color Macros (refer to Color Macros Chart section of this manual)
5	5					000 - 255	Red , 0% to 100%
6	6					000 - 255	Green , 0% to 100%
7	7					000 - 255	Blue , 0% to 100%
8	8					000 - 255	White , 0% to 100%
9	9	7	7	81	7	000 - 255	Color Temperature , 2700K to 7000K
		8	8	5	8	000 - 255	Red1 , 0% to 100%
		9	9	6	9	000 - 255	Green1 , 0% to 100%
		10	10	7	10	000 - 255	Blue1 , 0% to 100%
		11	11	8	11	000 - 255	White1 , 0% to 100%
		12	12	9	12	000 - 255	Red2 , 0% to 100%
		13	13	10	13	000 - 255	Green2 , 0% to 100%
		14	14	11	14	000 - 255	Blue2 , 0% to 100%
		15	15	12	15	000 - 255	White2 , 0% to 100%
		16	16	13	16	000 - 255	Red3 , 0% to 100%
		17	17	14	17	000 - 255	Green3 , 0% to 100%
		18	18	15	18	000 - 255	Blue3 , 0% to 100%
		19	19	16	19	000 - 255	White3 , 0% to 100%
				17	20	000 - 255	Red4 , 0% to 100%
				18	21	000 - 255	Green4 , 0% to 100%
				19	22	000 - 255	Blue4 , 0% to 100%
				20	23	000 - 255	White4 , 0% to 100%
				21	24	000 - 255	Red5 , 0% to 100%
				22	25	000 - 255	Green5 , 0% to 100%
				23	26	000 - 255	Blue5 , 0% to 100%
				24	27	000 - 255	White5 , 0% to 100%
				25	28	000 - 255	Red6 , 0% to 100%
				26	29	000 - 255	Green6 , 0% to 100%
				27	30	000 - 255	Blue6 , 0% to 100%
				28	31	000 - 255	White6 , 0% to 100%
				29	32	000 - 255	Red7 , 0% to 100%
				30	33	000 - 255	Green7 , 0% to 100%
				31	34	000 - 255	Blue7 , 0% to 100%
				32	35	000 - 255	White7 , 0% to 100%
				33	36	000 - 255	Red8 , 0% to 100%
				34	37	000 - 255	Green8 , 0% to 100%
				35	38	000 - 255	Blue8 , 0% to 100%
				36	39	000 - 255	White8 , 0% to 100%
				37	40	000 - 255	Red9 , 0% to 100%

DMX TRAITS: CHANNEL FUNCTIONS & VALUES

CHANNEL						DMX VALUES	FUNCTION
16CH	20CH	26CH	30CH	88CH	90CH		
				38	41	000 - 255	Green9 , 0% to 100%
				39	42	000 - 255	Blue9 , 0% to 100%
				40	43	000 - 255	White9 , 0% to 100%
				41	44	000 - 255	Red10 , 0% to 100%
				42	45	000 - 255	Green10 , 0% to 100%
				43	46	000 - 255	Blue10 , 0% to 100%
				44	47	000 - 255	White10 , 0% to 100%
				45	48	000 - 255	Red11 , 0% to 100%
				46	49	000 - 255	Green11 , 0% to 100%
				47	50	000 - 255	Blue11 , 0% to 100%
				48	51	000 - 255	White11 , 0% to 100%
				49	52	000 - 255	Red12 , 0% to 100%
				50	53	000 - 255	Green12 , 0% to 100%
				51	54	000 - 255	Blue12 , 0% to 100%
				52	55	000 - 255	White12 , 0% to 100%
				53	56	000 - 255	Red13 , 0% to 100%
				54	57	000 - 255	Green13 , 0% to 100%
				55	58	000 - 255	Blue13 , 0% to 100%
				56	59	000 - 255	White13 , 0% to 100%
				57	60	000 - 255	Red14 , 0% to 100%
				58	61	000 - 255	Green14 , 0% to 100%
				59	62	000 - 255	Blue14 , 0% to 100%
				60	63	000 - 255	White14 , 0% to 100%
				61	64	000 - 255	Red15 , 0% to 100%
				62	65	000 - 255	Green15 , 0% to 100%
				63	66	000 - 255	Blue15 , 0% to 100%
				64	67	000 - 255	White15 , 0% to 100%
				65	68	000 - 255	Red16 , 0% to 100%
				66	69	000 - 255	Green16 , 0% to 100%
				67	70	000 - 255	Blue16 , 0% to 100%
				68	71	000 - 255	White16 , 0% to 100%
				69	72	000 - 255	Red17 , 0% to 100%
				71	74	000 - 255	Blue17 , 0% to 100%
				72	75	000 - 255	White17 , 0% to 100%
				73	76	000 - 255	Red18 , 0% to 100%
				74	77	000 - 255	Green18 , 0% to 100%
				75	78	000 - 255	Blue18 , 0% to 100%
				76	79	000 - 255	White18 , 0% to 100%
				77	80	000 - 255	Red19 , 0% to 100%
				78	81	000 - 255	Green19 , 0% to 100%
				79	82	000 - 255	Blue19 , 0% to 100%
				80	83	000 - 255	White19 , 0% to 100%

DMX TRAITS: CHANNEL FUNCTIONS & VALUES

CHANNEL						DMX VALUES	FUNCTION	
16CH	20CH	26CH	30CH	88CH	90CH			
	10		20				Chase Patterns	
							000 - 014	Off
							015 - 030	Chase 1
							031 - 046	Chase 2
							047 - 062	Chase 3
							063 - 078	Chase 4
							079 - 094	Chase 5
							095 - 110	Chase 6
							111 - 126	Chase 7
							127 - 142	Chase 8
							143 - 158	Chase 9
							159 - 174	Chase 10
							175 - 190	Chase 11
							191 - 206	Chase 12
							207 - 222	Chase 13
					223 - 238	Chase 14		
					239 - 255	Chase 15		
	11		21				Chase Speed	
						000 - 125	Backward, fast to slow	
						126 - 130	Stop	
					131 - 255	Forward, slow to fast		
	12		22			000 - 255	Chase Fade	
10	13	20	23	82	84		Strobe	
						000 - 031	Shutter Closed	
						032 - 063	Shutter Open	
						064 - 095	Shutter Effect, slow to fast	
						096 - 127	Shutter Open	
						128 - 159	Pulse Effect in Sequences	
						160 - 191	Shutter Open	
						192 - 223	Random Strobe Effect, slow to fast	
224 - 255	Shutter Open							
11	14	21	24	83	85	000 - 255	Dimmer , 0% to 100%	
12	15	22	25	84	86	000 - 255	Dimmer Fine	
13	16	23	26	85	87	000 - 255	Zoom (Narrow to Wide)	
14		24		86	88		Dim Modes (16-, 26-, 88-, and 90-channel mode)	
			000 - 020			Standard		
			021 - 040			Stage		
			041 - 060			TV		
			061 - 080			Architectural		
			081 - 100			Theatre		
			101 - 120			Stage 2		
			121 - 140			Dim Speed, fast to slow (0.1s to 10s)		
	141 - 255	Default to unit setting						

DMX TRAITS: CHANNEL FUNCTIONS & VALUES

CHANNEL						DMX VALUES	FUNCTION
16CH	20CH	26CH	30CH	88CH	90CH		
	17		27				Dim Modes (20- and 30-channel modes)
						000 - 020	Default to unit setting
						021 - 040	Standard
						041 - 060	Stage
						061 - 080	TV
						081 - 100	Architectural
						101 - 120	Theatre
						121 - 140	Stage 2
						141 - 160	Dim Speed, fast to slow (0.1s to 10s)
						161 - 255	Default to unit setting
	18		28				Dim Curves
						000 - 020	Square
						021 - 040	Linear
						041 - 060	Inv. Squa.
						061 - 080	S. Curve
						081 - 255	No function
15	19	25	29	87	89	000 - 255	Pan/Tilt Speed, fast to slow
							Special Functions
						000 - 010	Default LED Refresh Rate (1200 Hz)
						011	900 Hz Refresh Rate
						012	1000 Hz Refresh Rate
						013	1100 Hz Refresh Rate
						014	1300 Hz Refresh Rate
						015	1400 Hz Refresh Rate
						016	1500 Hz Refresh Rate
						017	2500 Hz Refresh Rate
						018	4000 Hz Refresh Rate
						019	5000 Hz Refresh Rate
						020	6000 Hz Refresh Rate
						021	10,000 Hz Refresh Rate
						022	15,000 Hz Refresh Rate
						023	Default to unit setting
						024 - 079	No function
						080 - 089	Enable blackout while pan/tilt moving
						090 - 099	Disable blackout while pan/tilt moving
						100 - 139	No function
						140 - 149	Pan/tilt reset
						150 - 159	Zoom reset
						160 - 199	No function
						200 - 209	All reset
						210 - 255	No function
16	20	26	30	88	90		

COLOR MACRO CHART

Color No.	DMX Value	Red	Green	Blue	White
Off	000	0	0	0	0
Color1	001 - 004	80	255	234	80
Color2	005 - 008	80	255	164	80
Color3	009 - 012	77	255	112	77
Color4	013 - 016	117	255	83	83
Color5	017 - 020	160	255	77	77
Color6	021 - 024	223	255	83	83
Color7	025 - 028	255	243	77	77
Color8	029 - 032	255	200	74	74
Color9	033 - 036	255	166	77	77
Color10	037 - 040	255	125	74	74
Color11	041 - 044	255	97	77	74
Color12	045 - 048	255	71	77	71
Color13	049 - 052	255	83	134	83
Color14	053 - 056	255	93	182	93
Color15	057 - 060	255	96	236	96
Color16	061 - 064	238	93	255	93
Color17	065 - 068	196	87	255	87
Color18	069 - 072	150	90	255	90
Color19	073 - 076	100	77	255	77
Color20	077 - 080	77	100	255	77
Color21	081 - 084	67	148	255	67
Color22	085 - 088	77	195	255	77
Color23	089 - 092	77	234	255	77
Color24	093 - 096	158	255	144	144
Color25	097 - 100	255	251	153	153
Color26	101 - 104	255	175	147	147
Color27	105 - 108	255	138	186	138
Color28	109 - 112	255	147	251	147
Color29	113 - 116	151	138	255	138
Color30	117 - 120	99	0	255	100
Color31	121 - 124	1378	169	255	138
Color32	125 - 128	255	255	255	255

COLOR MACRO CHART

Color No.	DMX Value	Red	Green	Blue	White
Color33	129 - 132	255	206	143	0
Color34	133 - 136	254	177	153	0
Color35	137 - 140	254	192	138	0
Color36	141 - 144	254	165	98	0
Color37	145 - 148	254	121	0	0
Color38	149 - 152	176	17	0	0
Color39	153 - 156	96	0	11	0
Color40	157 - 160	234	139	171	0
Color41	161 - 164	224	5	97	0
Color42	165 - 168	175	77	173	0
Color43	169 - 172	119	130	199	0
Color44	173 - 176	147	164	212	0
Color45	177 - 180	88	2	163	0
Color46	181 - 184	0	38	86	0
Color47	185 - 188	0	142	208	0
Color48	189 - 192	52	148	209	0
Color49	193 - 196	1	134	201	0
Color50	197 - 200	0	145	212	0
Color51	201 - 204	0	121	192	0
Color52	205 - 208	0	129	184	0
Color53	209 - 212	0	83	115	0
Color54	213 - 216	0	97	166	0
Color55	217 - 220	1	100	167	0
Color56	221 - 224	0	40	86	0
Color57	225 - 228	209	219	182	0
Color58	229 - 232	42	165	85	0
Color59	233 - 236	0	46	35	0
Color60	237 - 240	8	107	222	0
Color61	241 - 244	255	0	0	0
Color62	245 - 248	0	255	0	0
Color63	249 - 252	0	0	255	0
Color64	253 - 255	0	0	0	255

COLOR TEMPERATURE CHART

DMX VALUES	TEMPERATURE
000 - 035	Off
036 - 040	2700K
041 - 045	2800K
046 - 050	2900K
051 - 055	3000K
056 - 060	3100K
061 - 065	3200K
066 - 070	3300K
071 - 075	3400K
076 - 080	3500K
081 - 085	3600K
086 - 090	3700K
091 - 095	3800K
096 - 100	3900K
101 - 105	4000K
106 - 110	4100K
111 - 115	4200K
116 - 120	4300K
121 - 125	4400K
126 - 130	4500K
131 - 135	4600K
136 - 140	4700K
141 - 145	4800K

DMX VALUES	TEMPERATURE
146 - 150	4900K
151 - 155	5000K
156 - 160	5100K
161 - 165	5200K
166 - 170	5300K
171 - 175	5400K
176 - 180	5500K
181 - 185	5600K
186 - 190	5700K
191 - 195	5800K
196 - 200	5900K
201 - 205	6000K
206 - 210	6100K
211 - 215	6200K
216 - 220	6300K
221 - 225	6400K
226 - 230	6500K
231 - 235	6600K
236 - 240	6700K
241 - 245	6800K
246 - 250	6900K
251 - 255	7000K

PIXEL ZONES

26-CHANNEL MODE / 30-CHANNEL MODE:

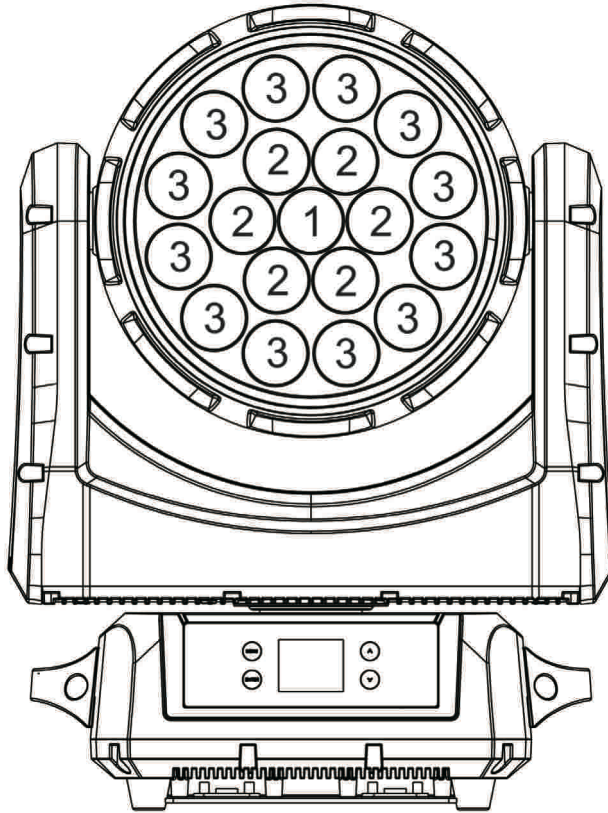

88-CHANNEL MODE / 90-CHANNEL MODE:

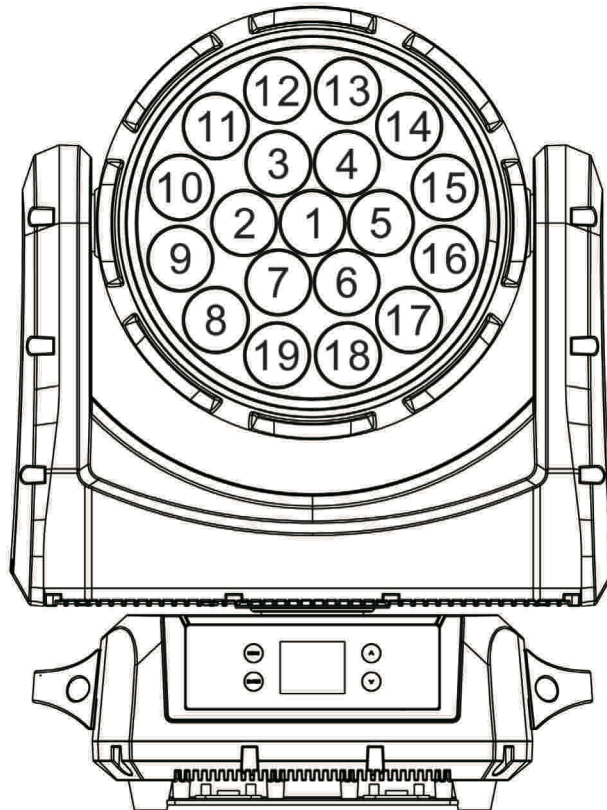

ERROR CODES

#	Print Error Message	Description
1	Pan Reset Error	Pan: Reset Error
2	Pan Encode Error	Pan: Encode Error
3	Tilt Reset Error	Tilt: Reset Error
4	Tilt Encode Error	Tilt: Encode Error
5	CPU-B Error	CPU-B Error
6	CPU-C Error	CPU-C Error
7	CPU-D Error	CPU-D Error
8	CPU-E Error	CPU-E Error
9	CPU-F Error	CPU-F Error
10	CPU-G Error	CPU-G Error
11	CPU-H Error	CPU-H Error
12	BaseFan1 start Error	BaseFan1 can't start
13	BaseFan1 stop Error	BaseFan1 can't stop
14	BaseFan2 start Error	BaseFan2 can't Start
15	BaseFan2 stop Error	BaseFan2 can't Stop
16	LEDFan1 Start Error	LEDFan1 can't start
17	LEDFan1 Stop Error	LEDFan1 can't stop
18	LEDFan1 speed too fast	LEDFan1 speed too fast
19	LEDFan1 speed too slow	LEDFan1 speed too slow
20	LEDFan2 Start Error	LEDFan2 LED can't start
21	LEDFan2 Stop Error	LEDFan2 LED can't stop
22	LEDFan2 speed too fast	LEDFan2 speed too fast
23	LEDFan2 speed too slow	LEDFan2 speed too slow
24	HeadFan1 Start Error	HeadFan1 can't start
25	HeadFan1 Stop Error	HeadFan1 can't stop
26	HeadFan1 Speed too fast	HeadFan1 speed too fast
27	HeadFan1 Speed too slow	HeadFan1 speed too slow
28	HeadFan2 Start Error	HeadFan2 can't start
29	HeadFan2 Stop Error	HeadFan2 can't stop
30	HeadFan2 speed too fast	HeadFan2 speed too fast
31	HeadFan2 speed too slow	HeadFan2 speed too slow
32	HeadFan3 Start Error	HeadFan3 can't start
33	HeadFan3 Stop Error	HeadFan3 can't stop
34	HeadFan3 speed too fast	HeadFan3 speed too fast
35	HeadFan3 speed too slow	HeadFan3 speed too slow
36	ArmFan Start Error	ArmFan can't start
37	ArmFan Stop Error	ArmFan can't stop
38	LED Temp: Too High	LED Temp: Too High
39	Head Humidity Error	Head Humidity Error
40	Base Humidity Error	Base Humidity Error

MULTIPLE UNIT POWER LINKING

With this feature you can connect the fixtures to one another using the power cable input and output sockets.



NOTE: USE CAUTION WHEN POWER LINKING OTHER FIXTURES AS THE POWER CONSUMPTION OF OTHER MODEL FIXTURES MAY EXCEED THE MAX POWER OUTPUT ON THIS FIXTURE! CHECK SILK SCREEN FOR MAX AMPS.

CLEANING

Due to fog residue, smoke, and dust cleaning the internal and external optical lenses must be carried out periodically to optimize light output.

- Use normal glass cleaner and a soft cloth to wipe down the outside casing.
- Clean the external optics with glass cleaner and a soft cloth every 20 days.
- Always be sure to dry all parts completely before plugging the unit back in.
- Cleaning frequency depends on the environment in which the fixture operates (i.e. smoke, fog residue, dust, dew).

SPECIFICATIONS

Light Source:

- 19x Osram 40W RGBW (4-IN-1) LEDs
- 7500 lumens

Features:

- IP65 outdoor rated – protects fixture from dust, sand, moisture and liquid (For Temporary Outdoor Use Only)
- Motorized Zoom: 6 ~ 40-degrees
- Firmware Upgrade: Update via IP65 Service Port (with rubber protective cover)
- Antenna Range: 98.42ft (30m)

Construction:

- Color display with touch buttons
- Data In/Out: 5-pin DMX IP65 (with rubber protective covers over connections)
- Power In: IP65 locking power input (with rubber protective covers over connection)
- All metal case design

Control:

- WiFLY EXR Wireless DMX built-in
- Fully pixel mappable
- 6 DMX channel modes: 16, 20, 26, 30, 88 & 90 channels
- Protocols: DMX-512, RDM (Remote Device Management), KlingNet and Artnet
- Control modes: DMX-512, KlingNet and Artnet
- 0-100% dimming plus 16-bit fine dimming
- 6 dimmer modes
- Strobe & pulse effects
- Gamma correction: 1.0, 2.0, 2.2, 2.4, 2.6 and 2.8
- With Wired Digital Communication Network

Pan/Tilt:

- Pan/Tilt: 540-degrees / 230-degrees
- 16-bit Fine Pan
- 16-bit Fine Tilt

Electrical:

- Multi-voltage operation: 100-240V, 50/60Hz
- Maximum power draw: 990W

Dimensions & Weight:

- Dimensions (LxWxH): 15.25" x 11" x 20.75" / 384x275x524mm
- Weight: 53 lbs. / 24 kg.

Approval / Ratings

- CEI cETLus IIP65 Approved (Control # 4000358)



Please Note: Specifications and improvements in the design of this unit and this manual are subject to change.

DIMENSIONS

*Drawings not to scale. Specifications and improvements in the design of this unit and this manual are subject to change without notice.

