



# FOCUS SPOT 6Z



## User Manual

©2022 ADJ Products, LLC all rights reserved. Information, specifications, diagrams, images, and instructions herein are subject to change without notice. ADJ Products, LLC logo and identifying product names and numbers herein are trademarks of ADJ Products, LLC. Copyright protection claimed includes all forms and matters of copyrightable materials and information now allowed by statutory or judicial law or hereinafter granted. Product names used in this document may be trademarks or registered trademarks of their respective companies and are hereby acknowledged. All non-ADJ Products, LLC brands and product names are trademarks or registered trademarks of their respective companies.

**ADJ Products, LLC** and all affiliated companies hereby disclaim any and all liabilities for property, equipment, building, and electrical damages, injuries to any persons, and direct or indirect economic loss associated with the use or reliance of any information contained within this document, and/or as a result of the improper, unsafe, insufficient and negligent assembly, installation, rigging, and operation of this product.

## DOCUMENT VERSION



Due to additional product features and/or enhancements, an updated version of this document may be available online.

Please check [www.adj.com](http://www.adj.com) for the latest revision/update of this manual before beginning installation and/or programming.

Date	Document Version	Software Version	DMX Channels	Notes
07/31/2020	1.0	1.2.1	21 / 25 / 29 ch.	Initial Release
08/11/2020	1.1	NC	No Change	Updated Gobo Replacement
09/10/2020	1.2	1.2.2	No Change	Updated System Menu, DMX Traits, Primary-Secondary Setup
03/29/2022	1.3	NC	No Change	Removed wireless indicator; updated Safety Guidelines, Installation Guidelines, Gobos, Color Wheels, Specifications; added Maintenance Guidelines
06/10/2022	1.4	NC	No Change	Updated Gobos and Color Wheels; added RDM

Europe Energy Saving Notice

Energy Saving Matters (EuP 2009/125/EC)

Saving electric energy is a key to help protecting the environment. Please turn off all electrical products when they are not in use. To avoid power consumption in idle mode, disconnect all electrical equipment from power when not in use. Thank you!

## TABLE OF CONTENTS

Introduction	4
Limited Warranty (USA Only)	5
Features   Warranty Registration	6
Safety Precautions	7
Installation	8
Remote Device Management (RDM)	12
Maintenance Guidelines	13
Overview	14
DMX Set Up	15
DMX Addressing	17
DMX Traits	18
System Menu	25
Primary-Secondary Set Up	29
Dimmer Modes	30
Gobo Replacement	31
Gobos	35
Color Wheels	36
Multi Unit Power Linking   Trouble Shooting   Cleaning	39
Specifications	40

## INTRODUCTION

**Unpacking:** Thank you for purchasing the Focus Spot 6Z by ADJ Products, LLC. Every device has been thoroughly tested and has been shipped in perfect operating condition. Carefully check the shipping carton for damage that may have occurred during shipping. If the carton appears to have been damaged, carefully inspect your fixture for any damage and be sure all accessories necessary to operate the unit have arrived intact. In the event that damage has been found or parts are missing, please contact our toll free customer support number for further instructions. Do not return this unit to your dealer without first contacting customer support.

**Introduction:** The Focus Spot 6Z is a DMX intelligent, moving head LED fixture. This fixture can be used in stand alone mode, or connected in a Primary-Secondary configuration. The fixture comes equipped with motorized focus and zoom, 6 different dimming options, and 3 DMX channel modes (21, 25, or 29 channels). **This product is intended to be used by professionally trained personnel only and is not suitable for private use.**

**Customer Support:** Contact ADJ Service for any product related service and support needs. Also visit [forums.adj.com](http://forums.adj.com) with questions, comments or suggestions.

**Parts:** To purchase parts online visit:

<http://parts.adj.com> (US)

<http://www.adjparts.eu> (EU)

**ADJ SERVICE USA - Monday - Friday 8:00am to 4:30pm PST**

**Voice: 800-322-6337 | Fax: 323-582-2941 | [support@adj.com](mailto:support@adj.com)**

**ADJ SERVICE EUROPE - Monday - Friday 08:30 to 17:00 CET**

**Voice: +31 45 546 85 60 | Fax: +31 45 546 85 96 | [support@adj.eu](mailto:support@adj.eu)**

### **ADJ PRODUCTS LLC USA**

6122 S. Eastern Ave. Los Angeles, CA. 90040

323-582-2650 | Fax 323-532-2941 | [www.adj.com](http://www.adj.com) | [info@adj.com](mailto:info@adj.com)

### **ADJ SUPPLY Europe B.V**

Junostraat 2 6468 EW Kerkrade, The Netherlands

+31 (0)45 546 85 00 | Fax +31 45 546 85 99

[www.americandj.eu](http://www.americandj.eu) | [info@americandj.eu](mailto:info@americandj.eu)

### **ADJ PRODUCTS GROUP Mexico**

AV Santa Ana 30 Parque Industrial Lerma, Lerma, Mexico 52000

+52 (728) 282-7070

**WARNING!** This unit is intended for indoor use only! Do not expose to rain or moisture!

**CAUTION!** There are no user serviceable parts inside this unit. Do not attempt any repairs yourself, as doing so will void your manufacturer's warranty. In the unlikely event your unit may require service, please contact ADJ Products, LLC.

*Do not discard the shipping carton in the trash. Please recycle when ever possible.*

## LIMITED WARRANTY (USA ONLY)

- A. ADJ Products, LLC hereby warrants, to the original purchaser, ADJ Products, LLC products to be free of manufacturing defects in material and workmanship for a prescribed period from the date of purchase (see specific warranty period on reverse). This warranty shall be valid only if the product is purchased within the United States of America, including possessions and territories. It is the owner's responsibility to establish the date and place of purchase by acceptable evidence, at the time service is sought.
- B. For warranty service, you must obtain a Return Authorization number (RA#) before sending the product back—please contact ADJ Products, LLC Service Department at 800-322-6337. Send the product only to the ADJ Products, LLC factory. All shipping charges must be prepaid. If the requested repairs or service (including parts replacement) are within the terms of this warranty, ADJ Products, LLC will pay return shipping charges only to a designated point within the United States. If the entire instrument is sent, it must be shipped in its original package and packaging material. No accessories should be shipped with the product. If any accessories are shipped with the product, ADJ Products, LLC shall incur no liability whatsoever for loss of or damage to any such accessories, nor for the safe return thereof.
- C. This warranty is void if the product serial number and/or labels are altered or removed; if the product is modified in any manner which ADJ Products, LLC concludes, after inspection, affects the reliability of the product; if the product has been repaired or serviced by anyone other than the ADJ Products, LLC factory unless prior written authorization was issued to purchaser by ADJ Products, LLC; if the product is damaged because it was not properly maintained as set forth in the product instructions, guidelines and/or user manual.
- D. This is not a service contract, and this warranty does not include maintenance, cleaning, or periodic checkup. During the period specified above, ADJ Products, LLC will replace defective parts at its expense with new or refurbished parts, and will absorb all expenses for warranty service and repair labor by reason of defects in material or workmanship. The sole responsibility of ADJ Products, LLC under this warranty shall be limited to the repair of the product, or replacement thereof, including parts, at the sole discretion of ADJ Products, LLC. All products covered by this warranty were manufactured after August 15, 2012, and bear identifying marks to that effect.
- E. ADJ Products, LLC reserves the right to make changes in design and/or improvements upon its products without any obligation to include these changes in any products theretofore manufactured.
- F. No warranty, whether expressed or implied, is given or made with respect to any accessory supplied with products described above. Except to the extent prohibited by applicable law, all implied warranties made by ADJ Products, LLC in connection with this product, including warranties of merchantability or fitness, are limited in duration to the warranty period set forth above. And all warranties, whether expressed or implied, including warranties of merchantability or fitness, are limited in duration to the warranty period set forth above. The consumer's and/or dealer's sole remedy shall be such repair or replacement as is expressly provided above; and under no circumstances shall ADJ Product, LLC be liable for any loss and/or damage, direct and/or consequential arising out of the use of, and/or inability to use this product.
- G. This warranty is the only written warranty applicable to ADJ Products, LLC products, and supersedes all prior warranties and written descriptions of warranty terms and conditions heretofore published.

### MANUFACTURER'S LIMITED WARRANTY PERIODS:

- Non-LED Lighting Products = 1-Year (365 Days) (Including Special Effect Lighting, Intelligent Lighting, UV lighting, Strobes, Fog Machines, Bubble Machines, Mirror Balls, Par Cans, Trussing, Lighting Stands, Power/Data Distribution, etc. excluding LED and lamps)
- Laser Products = 1-Year (365 Days) (excluding laser diodes which have a 6-Month Limited Warranty)
- LED Products = 2-Year (730 Days) (excluding batteries which have a 180 Day Limited Warranty)
- NOTE: 2-Year (730 Days) Limited Warranty ONLY applies to product purchased within the United States.
- StarTec Series = 1-Year (365 Days) (excluding batteries which have a 180 Day Limited Warranty)
- ADJ DMX Controllers = 2 Year (730 Days)
- American Audio Products = 1 Year (365 Days)

## **FEATURES**

- Motorized Focus
- 2 Frost Filters to create wash effects
- Motorized Zoom: 9~28 degrees
- 2 Prism FX: Rotating 6-facet Linear & Rotating 6-facet Circular
- Motorized Iris
- Motorized Shutter
- GOBO Morphing
- 0-100% smooth dimming
- Various strobe speeds
- USB firmware update port

## **INCLUDED ITEMS**

- Locking Power Cord (x1)
- Omega Bracket (x2)

## **WARRANTY REGISTRATION**

The Focus Spot 6Z carries a 2 year limited warranty. Please fill out the enclosed warranty card to validate your purchase. All returned service items, whether under warranty or not, must be freight pre-paid and accompanied by a return authorization (R.A.) number. The R.A. number must be clearly written on the outside of the return package. A brief description of the problem as well as the R.A. number must also be written down on a piece of paper included in the shipping carton. If the unit is under warranty, you must provide a copy of your proof of purchase invoice. You may obtain an R.A. number by contacting our customer support team. All packages returned to the service department not displaying an R.A. number on the outside of the package will be returned to the shipper.

## SAFETY PRECAUTIONS



**PROTECTION CLASS 1 - FIXTURE MUST BE PROPERLY GROUNDED.**



**THERE ARE NO USER SERVICEABLE PARTS INSIDE THIS UNIT. DO NOT ATTEMPT ANY REPAIRS YOURSELF, AS DOING SO WILL VOID YOUR MANUFACTURER'S WARRANTY. DAMAGES RESULTING FROM MODIFICATIONS TO THIS FIXTURE AND/OR THE DISREGARD OF SAFETY INSTRUCTIONS AND GUIDELINES IN THIS MANUAL VOID THE MANUFACTURER'S WARRANTY AND ARE NOT SUBJECT TO ANY WARRANTY CLAIMS AND/OR REPAIRS.**



**NEVER LOOK DIRECTLY INTO THE LIGHT SOURCE!  
RETINA INJURY RISK - MAY INDUCE BLINDNESS!  
SENSITIVE PERSONS MAY SUFFER AN EPILEPTIC SHOCK!**

- **Maximum ambient operating temperature is 113° F (45° C)!**
- DO NOT TOUCH the fixture housing during operation. Disconnect the power and allow approximately 15 minutes for the fixture to cool down before servicing.
- DO NOT shake the fixture, and avoid brute force when installing and/or operating the fixture.
- DO NOT operate the fixture if the power cord has become frayed, crimped and/or damaged. If the power cord is damaged, replace immediately with a new one of the same power rating.
- DO NOT attempt to remove or break off the ground prong from the electrical cord. This prong is used to reduce the risk of electrical shock and fire in case of an internal short.
- DO NOT attempt to operate this unit if it has been damaged in any way.
- DO NOT spill water or other liquids into or on to your unit.
- This unit is intended for indoor use only. Use of this product outdoors voids all warranties.
- To reduce the risk of electrical shock or fire, do not expose this unit rain or moisture.
- Disconnect from main power before making any type of connection.
- DO NOT block any air ventilation slots. All fan and air inlets must remain clean and never blocked. Allow approx. 6" (15cm) between fixture and other devices or a wall for proper cooling.
- Always be sure to mount this unit in an area that will allow proper ventilation. Allow about 6" (15cm) between this device and a wall.
- During the initial operation of this fixture, a light smoke or smell may emit from the interior of the fixture. This is a normal process and is caused by excess paint in the interior of the casing burning off from the heat. This will decrease gradually over time.
- DO NOT remove the cover under for any reason.
- When installing fixture in a suspended environment, always use mounting hardware that is no less than M10 x 25mm, and always install fixture with an appropriately rated safety cable.
- Never plug this unit in to a dimmer pack.
- During long periods of non-use, disconnect the unit's main power.
- Always mount this unit in safe and stable matter.
- Power-supply cords should be routed so that they are not likely to be walked on or pinched by items placed upon or against them, paying particular attention to the point where they exit from the unit.
- Cleaning - The fixture should be cleaned only as recommended by the manufacturer.
- Heat - The appliance should be situated away from heat sources such as radiators, heat registers, stoves, or other appliances (including amplifiers) that produce heat.
- The fixture should be serviced by qualified service personnel when:
  - A. The power-supply cord or the plug have been damaged.
  - B. Objects have fallen onto, or liquid has been spilled into, the fixture.
  - C. The fixture has been exposed to rain or water.
  - D. The fixture does not appear to operate normally or exhibits a marked change in performance.
  - E. The fixture has fallen and/or has been subjected to extreme handling.

## INSTALLATION



**DO NOT INSTALL THE FIXTURE IF YOU ARE NOT QUALIFIED TO DO SO!**

Fixture **MUST** be installed following all local, national, and country commercial electrical and construction codes and regulations.

Before rigging/mounting a single fixture to any metal truss/structure or placing the fixture(s) on any surface, a professional equipment installer **MUST** be consulted to determine if the metal truss/structure or surface is properly certified to safely hold the combined weight of the fixture(s), clamps, cables, and accessories.

Maximum ambient operating temperature is **-113°F (45°C)**.

Fixture(s) should be installed in areas outside walking paths, seating areas, or areas where unauthorized personnel might reach the fixture by hand.

**NEVER** stand directly below the fixture(s) when rigging, removing, or servicing.

Overhead fixture installation must always be secured with a secondary safety attachment, such as an appropriately rated safety cable that can hold 10 times the weight of the fixture. Allow approximately 15 minutes for the fixture to cool down before serving.

# INSTALLATION

## POTENTIAL INTERNAL FIXTURE DAMAGE FROM EXTERNAL SOURCES OF LIGHT BEAMS

External sources of light beams from direct sunlight, lighting and moving head fixtures, and lasers, which are focused directly towards the exterior housing and/or penetrate the front lens opening of ADJ lighting fixtures, can cause severe internal damage including burning of optics, dichroic color filters, glass and metal gobos, prisms, animation wheels, frost filters, iris, shutters, motors, belts, wiring, discharge lamps, and LEDs.

This issue is not specific only to ADJ lighting fixtures, but rather it is a common issue with lighting fixtures from all manufacturers. Although there is no true way to fully prevent this issue from happening, the guidelines below can reduce the risk of potential damage. Contact ADJ Service for more details.

**DO NOT EXPOSE THE FIXTURE AND/OR FRONT LENS OPENING TO LIGHT BEAMS FROM DIRECT SUNLIGHT, OTHER LIGHTING OR MOVING HEAD FIXTURES, AND LASERS DURING UNPACKING, INSTALLATION, USE, AND EXTENDED IDLE TIMES OUTDOORS. DO NOT FOCUS A LIGHT BEAM FROM ONE LIGHTING FIXTURE DIRECTLY TOWARDS ANOTHER.**

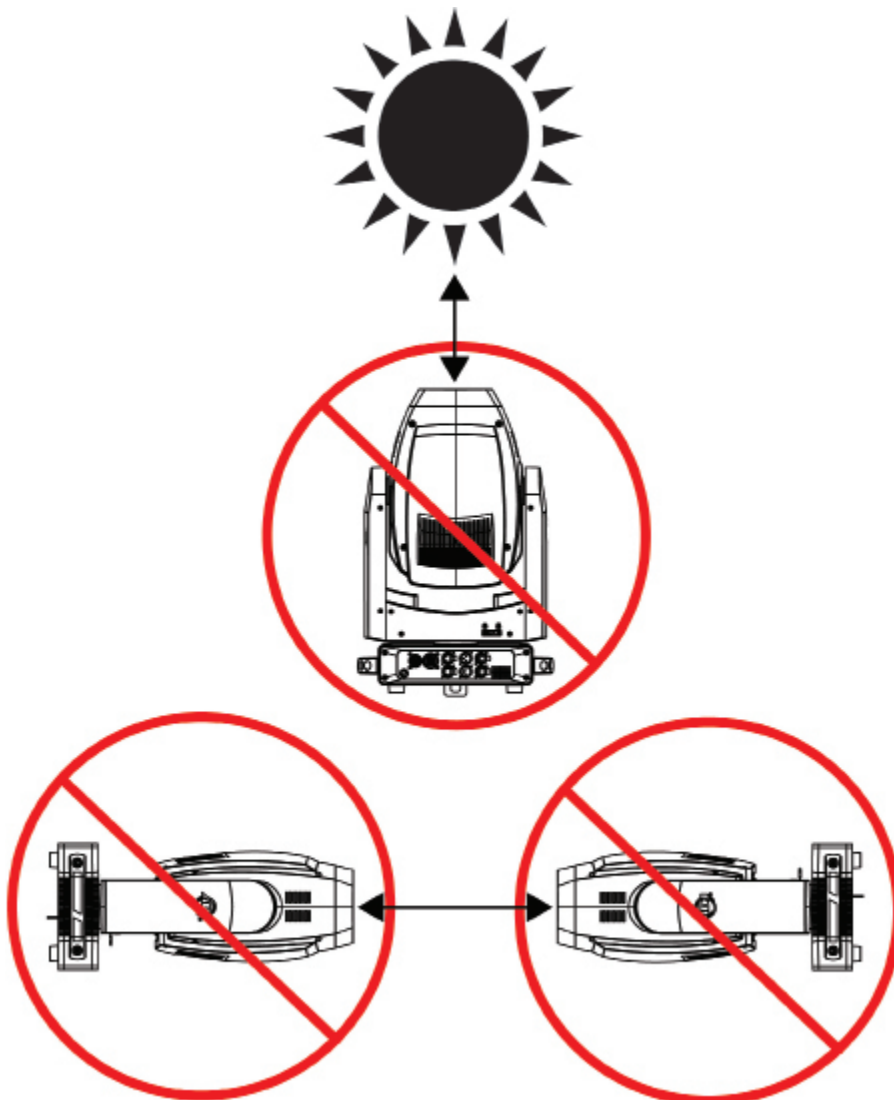

## INSTALLATION

Screw one clamp into each Omega bracket using an M12 screw and nut. Insert the quick-lock fasteners of the Omega holders into the respective holes on the bottom of the unit. Tighten the quick-lock fasteners fully clockwise. Pull the safety cable through the openings located on the base plate and over the trussing system or a safe fixation spot. Insert the end in the carabine and tighten the safety screw.

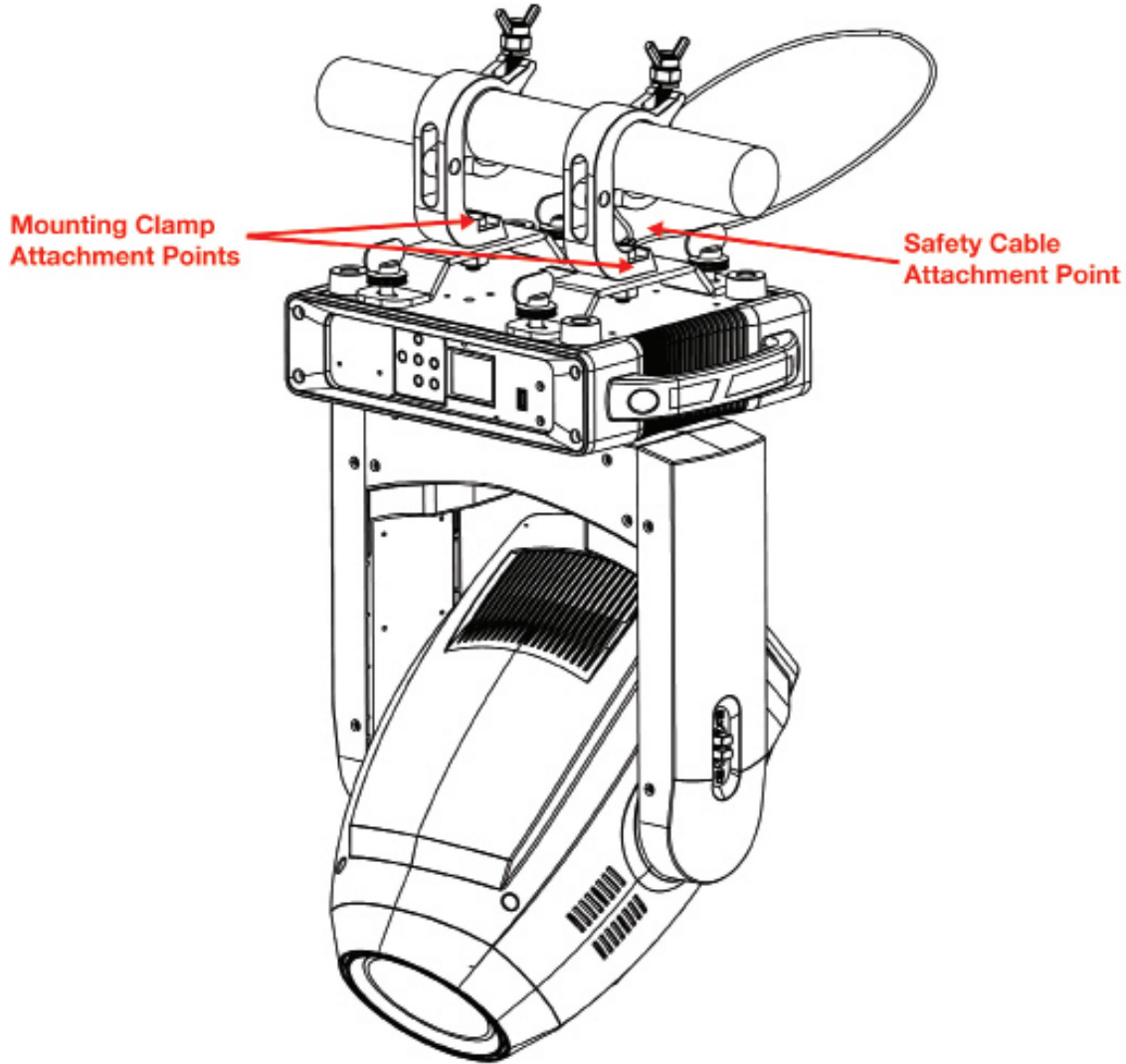

When installing the unit, the trussing or area of installation must be able to hold 10 times the weight of the unit and any attached accessories without any deformation. The unit must be secured with a secondary safety attachment, e.g. an appropriately-rated safety cable. Never stand directly below the unit when mounting, removing, or servicing the unit.

Overhead mounting requires extensive experience, including calculating working load limits, knowledge of installation material being used, and periodic safety inspection of all installation material as well as the unit itself. If you lack these qualifications, do not attempt the installation yourself.

The installation should be checked by a skilled person once a year.

## INSTALLATION

**NOTICE:** The maximum ambient operational temperature for this lighting fixture is **113° F (45° C)**. Do not place this lighting fixture in an environment where the temperatures exceed this value. This will allow the fixture to run at its best and help prolong the fixture life.

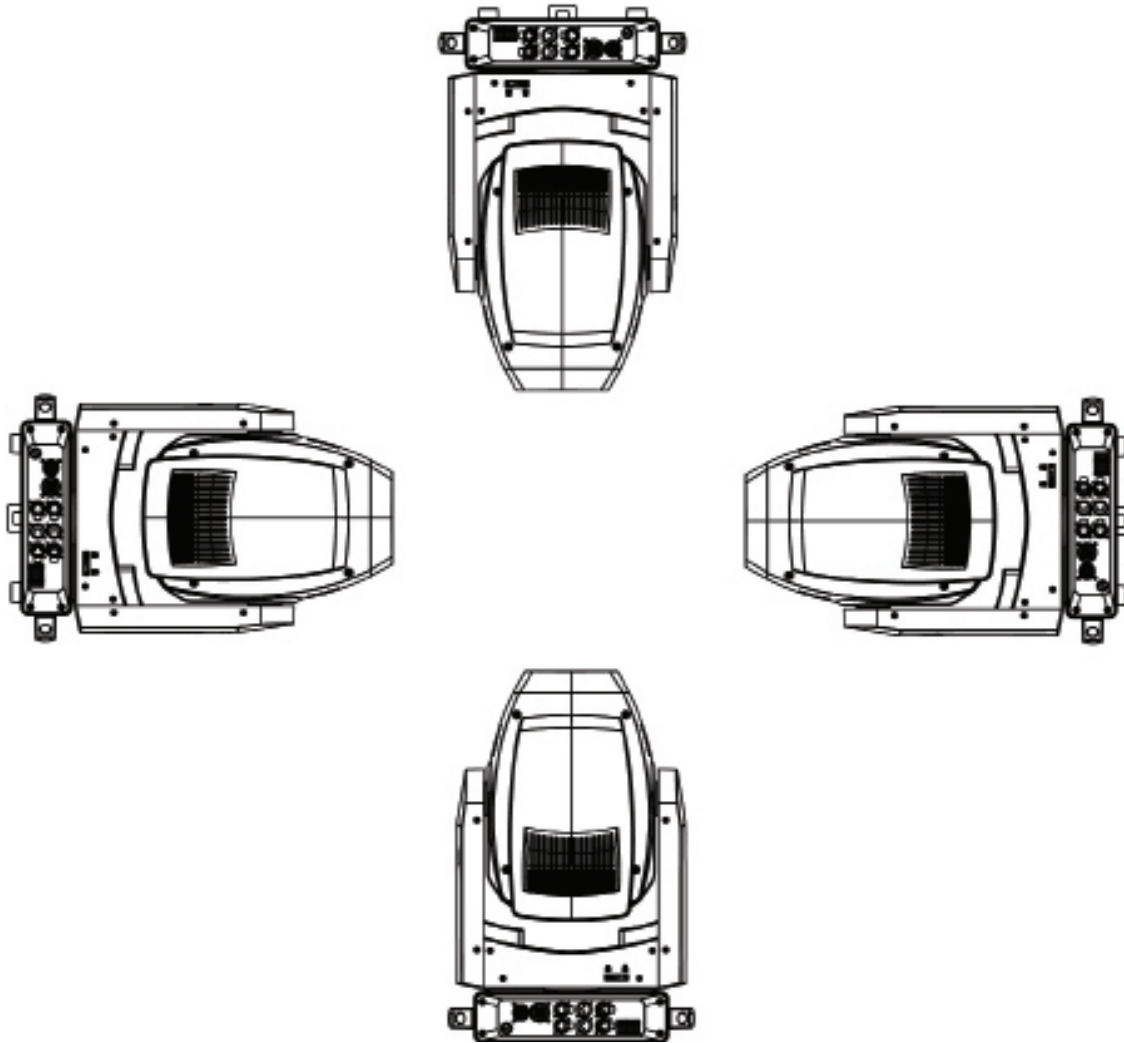

The unit is fully operational in three different mounting positions: hanging upside-down from the ceiling or trussing, sideways on trussing, or set on a flat level surface. Be sure this fixture is kept at least 12m (40ft) away from any flammable materials (decorations, etc). Always use and install a safety cable (not included) as a safety measure to prevent accidental damage and/or injury in the event the clamp fails. Never use the carrying handles for secondary attachment.

## REMOTE DEVICE MANAGEMENT (RDM)

**NOTE: In order for RDM to work properly, RDM enabled equipment must be used throughout the entire system, including DMX data splitters and wireless systems.**

Remote Device Management (RDM) is a protocol that sits on top of the DMX512 data standard for lighting, allowing the DMX systems of the fixtures to be modified and monitored remotely. This protocol is ideal for instances in which a unit is installed in a location that is not easily accessible.

With RDM, the DMX512 system becomes bi-directional, allowing a compatible RDM enabled controller to send out a signal to devices on the wire, as well as allowing the fixture to respond (known as a *GET* command). The controller can then use its *SET* command to modify settings that would typically have to be changed or viewed directly via the unit's display screen, including the DMX Address, DMX Channel Mode, and Temperature Sensors.

### FIXTURE RDM INFORMATION:

RDM Code	Device ID	Device Model ID	Personality ID
0x1900	0002	4166	001 Standard (25) 002 Basic (21) 003 Extend (29)

**Please be aware that not all RDM devices support all RDM features**, and therefore it is important to check beforehand to ensure that the equipment that you are considering includes all of the features that you require.

The following parameters are accessible in RDM on this device:

Proxied Device Count	Clear Status ID	Realtime Clock
Sensor Definition	Lamp Hours	Power State
Sensor Value	Lamp Strikes	Preset Playback
Device Model Description	Lamp State	Default Slot Value
Manufacturer Label	Lamp Mode	Language
Device Label	Device Power Cycles	Language Capabilites
DMX Personality	Pan Invert	Boot Software Version Label
DMX Personality Description	Tilt Invert	Boot Software Version ID
Device Hours	Pan Tilt Swap	Product Detail ID List
Comms Status	Display Invert	Status Messages
Status ID Description	Display Level	Reset Device

# MAINTENANCE GUIDELINES



**DISCONNECT POWER BEFORE PERFORMING ANY MAINTENANCE!**

## CLEANING

Frequent cleaning is recommended to ensure proper function, optimized light output, and an extended life. The frequency of cleaning depends on the environment in which the fixture operates: damp, smoky, or particularly dirty environments can cause greater accumulation of dirt on the fixture's optics. Clean the external lens surface regularly with a soft cloth to avoid dirt/debris accumulation.

**NEVER** use alcohol, solvents, or ammonia-based cleaners.

## MAINTENANCE

Regular inspections are recommended to ensure proper function and extended life. There are no user serviceable parts inside this fixture. Please refer all other service issues to an authorized ADJ service technician. Should you need any spare parts, please order genuine parts from your local ADJ dealer.

Please refer to the following points during routine inspections:

- A. A detailed electrical check by an approved electrical engineer every three months, to make sure the circuit contacts are in good condition and prevent overheating.
- B. Be sure all screws and fasteners are securely tightened at all times. Loose screws may fall out during normal operation, resulting in damage or injury as larger parts could fall.
- C. Check for any deformations on the housing, color lenses, rigging hardware, and rigging points (ceiling, suspension, trussing). Deformations in the housing could allow for dust to enter into the fixture. Damaged rigging points or unsecured rigging could cause the fixture to fall and seriously injure a person(s).
- D. Electric power supply cables must not show any damage, material fatigue, or sediments.

**NEVER** remove the ground prong from the power cable.

## FUSE REPLACEMENT

Unplug the unit from any power source it may be connected to. Once the power has been disconnected, use a flat head screw driver to unscrew the fuse holder located next to the power input. Remove the bad fuse and replace with a new one, and screw the fuse holder back in. Only replace fuse with a new fuse of the same type and rating.

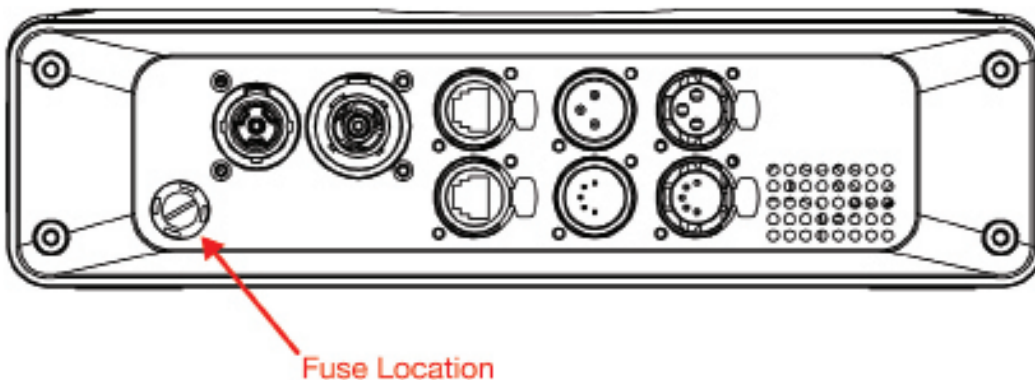

## OVERVIEW

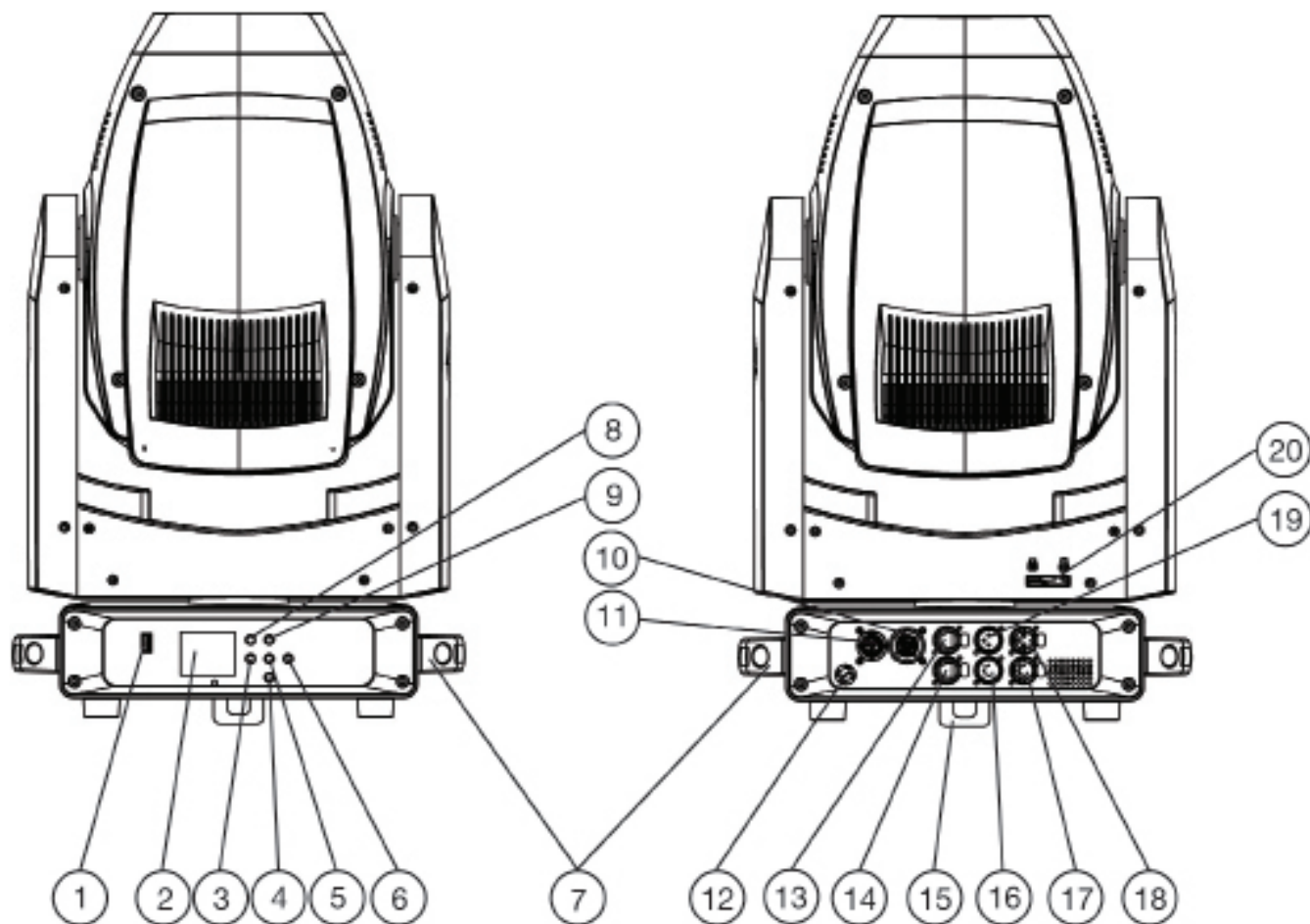

1. Service Port
2. Display Screen
3. Left Button
4. Down Button
5. Enter Button
6. Right Button
7. Carry Handles
8. Mode Button
9. Up Button
10. Power Out

11. Power In
12. Fuse T5A/250V
13. Net In
14. Net Out
15. Safety Cable Attachment Point
16. 5-pin DMX In
17. 5-pin DMX Out
18. 3-pin DMX Out
19. 3-pin DMX In
20. Pan Lock

# DMX SET UP

**DMX-512:** DMX is short for Digital Multiplex. This is a universal protocol used as a form of communication between intelligent fixtures and controllers. A DMX controller sends DMX data instructions from the controller to the fixture. DMX data is sent as serial data that travels from fixture to fixture via the DATA “IN” and DATA “OUT” XLR terminals located on all DMX fixtures (most controllers only have a DATA “OUT” terminal).

**DMX Linking:** DMX is a language allowing all makes and models of different manufacturers to be linked together and operate from a single controller, as long as all fixtures and the controller are DMX compliant. To ensure proper DMX data transmission, try to use the shortest cable path possible when linking several DMX fixtures. The order in which fixtures are connected in a DMX line does not influence the DMX addressing. For example, a fixture assigned a DMX address of 1 may be placed anywhere in a DMX line: at the beginning, at the end, or anywhere in the middle. When a fixture is assigned a DMX address of 1, the DMX controller knows to send DATA assigned to address 1 to that unit, no matter where it is located in the DMX chain.

**Data Cable (DMX Cable) Requirements (For DMX Operation):** This unit can be controlled via DMX-512 protocol. The DMX address is set on the front panel of the unit. Your unit and your DMX controller require a standard 3-pin XLR connector for data input and data output. We recommend Accu-Cable DMX cables. If you are making your own cables, be sure to use standard 110-120 Ohm shielded cable (This cable may be purchased at almost all pro lighting stores). Your cables should be made with a male XLR connector at one end and a female XLR connector at the other. Also remember that DMX cable must be daisy chained and cannot be split.

**Notice:** Be sure to follow figures 1 and 2 when making your own cables. Do not use the ground lug on the XLR connector. Do not connect the cable’s shield conductor to the ground lug or allow the shield conductor to come in contact with the XLR’s outer casing. Grounding the shield could cause a short circuit and erratic behavior.

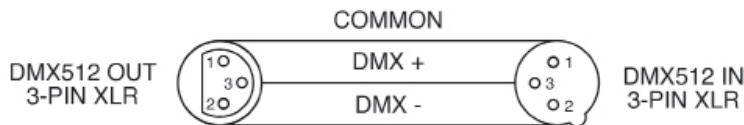

Figure 1

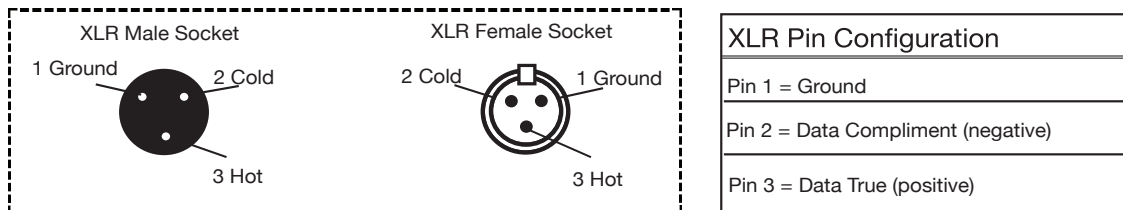
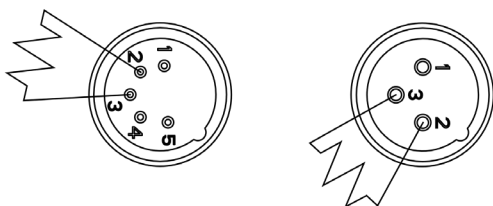

Figure 2

## DMX SET UP

**Special Note: Line Termination.** When longer runs of cable are used, you may need to use a terminator on the last unit to avoid erratic behavior. A terminator is a 110-120 ohm 1/4 watt resistor which is connected between pins 2 and 3 of a male XLR connector (DATA + and DATA -). This unit is inserted in the female XLR connector of the last unit in your daisy chain to terminate the line. Using a cable terminator (ADJ part number Z-DMX/T) will reduce the risk of erratic behavior.



A DMX512 terminator reduces signal errors, avoiding most signal reflection interference. Connect PIN 2 (DMX-) and PIN 3 (DMX+) of the last fixture in series with a 120 Ohm, 1/4 W Resistor to terminate the DMX512.

**5-Pin XLR DMX Connectors.** Some manufacturers use 5-pin DMX-512 data cables for DATA transmission in place of 3-pin. 5-pin DMX fixtures may be implemented in a 3-pin DMX line by using a cable adaptor. These adaptors are readily available at most electric stores. The chart below details a proper cable conversion.

3-Pin XLR to 5-Pin XLR Conversion		
Conductor	3-Pin XLR Female (Out)	5-Pin XLR Male (In)
Ground/Shield	Pin 1	Pin 1
Data Compliment (- signal)	Pin 2	Pin 2
Data True (+ signal)	Pin 3	Pin 3
Not Used		Do Not Use
Not Used		Do Not Use

## DMX ADDRESSING

All fixtures should be given a DMX starting address when using a DMX controller, so the correct fixture responds to the correct control signal. This digital starting address is the channel number from which the fixture starts to “listen” to the digital control signal sent out from the DMX controller. The assignment of this starting DMX address is achieved by setting the correct DMX address on the digital control display on the fixture.

You can set the same starting address for all fixtures or a group of fixtures, or set different addresses for each individual fixture. Setting all fixtures to the same DMX address will cause all fixtures to react in the same way. In other words, changing the settings of one channel will affect all the fixtures simultaneously.

If you set each fixture to a different DMX address, each unit will start to “listen” to the channel number you have set, based on the quantity of DMX channels of each fixture. That means changing the settings of one channel will only affect the selected fixture.

For example, when this unit is operating in 21 channel mode, you should set the starting DMX address of the first unit to 1, the second unit to 22 (1 + 21), the third unit to 43 (1 + 21 + 21), and so on. See the chart below for more details.

CHANNEL MODE	UNIT 1 ADDRESS	UNIT 2 ADDRESS	UNIT 3 ADDRESS	UNIT 4 ADDRESS
21 Ch	1	22	41	64
25 Ch	1	26	51	76
29 Ch	1	30	59	88

# DMX TRAITS

CHANNEL			DMX VALUES	FUNCTION
BASIC	STANDARD	EXT		
1	1	1	000 - 255	<b>Pan Movement</b> , 8-bit
	2	2	000 - 255	<b>Pan Fine</b> , 16-bit
2	3	3	000 - 255	<b>Tilt Movement</b> , 8-bit
	4	4	000 - 255	<b>Tilt Fine</b> , 16-bit
3	5	5		<b>Color Wheel 1</b>
			000 - 015	Open / white
			016 - 031	Red
			032 - 047	Orange
			048 - 063	Green
			064 - 079	Light Blue
			080 - 095	Purple
			096 - 111	Magenta
			112 - 127	Yellow
			128 - 189	Clockwise, fast to slow
			190 - 193	No rotation
			194 - 255	Counter-clockwise, slow to fast
4	6	6		<b>Color Wheel 2</b>
			000 - 015	Open / white
			016 - 031	Orange Red
			032 - 047	Yellow Green
			048 - 063	Peacock Blue
			064 - 079	CTO
			080 - 095	CTB
			096 - 111	Fluorescent Blue
			112 - 127	Light Yellow
			128 - 189	Clockwise, fast to slow
			190 - 193	No rotation
			194 - 255	Counter-clockwise, slow to fast
5	7	7		<b>Gobo 1, Continuous Rotation</b>
			000 - 009	Open
			010 - 019	Gobo 1
			020 - 029	Gobo 2
			030 - 039	Gobo 3
			040 - 049	Gobo 4
			050 - 059	Gobo 5
			060 - 069	Gobo 6

CONTINUED ON NEXT PAGE

# DMX TRAITS

CHANNEL			DMX VALUES	FUNCTION
BASIC	STANDARD	EXT		
5	7	7		<b><i>Gobo 1, Continuous Rotation (continued)</i></b>
			070 - 079	Gobo 7
			080 - 094	Gobo 1 Shake, slow to fast
			095 - 109	Gobo 2 Shake, slow to fast
			110 - 124	Gobo 3 Shake, slow to fast
			125 - 139	Gobo 4 Shake, slow to fast
			140 - 154	Gobo 5 Shake, slow to fast
			155 - 169	Gobo 6 Shake, slow to fast
			170 - 189	Gobo 7 Shake, slow to fast
			190 - 221	Clockwise, fast to slow
			222 - 223	No rotation
			224 - 255	Counter-clockwise, slow to fast
			6	8
000 - 127	Indexing			
128 - 189	Clockwise, fast to slow			
190 - 193	No rotation			
7	9	9		<b><i>Gobo 2, Continuous Rotation</i></b>
			000 - 009	Open
			010 - 019	Gobo 1
			020 - 029	Gobo 2
			030 - 039	Gobo 3
			040 - 049	Gobo 4
			050 - 059	Gobo 5
			060 - 069	Gobo 6
			070 - 079	Gobo 7
			080 - 094	Gobo 1 Shake, slow to fast
			095 - 109	Gobo 2 Shake, slow to fast
			110 - 124	Gobo 3 Shake, slow to fast
			125 - 139	Gobo 4 Shake, slow to fast
			140 - 154	Gobo 5 Shake, slow to fast
			155 - 169	Gobo 6 Shake, slow to fast
170 - 189	Gobo 7 Shake, slow to fast			
190 - 221	Clockwise, fast to slow			
222 - 223	No rotation			
224 - 255	Counter-clockwise, slow to fast			

CONTINUED ON NEXT PAGE

# DMX TRAITS

CHANNEL			DMX VALUES	FUNCTION
BASIC	STANDARD	EXT		
8	10	10		<b>Gobo 2 Rotation</b>
			000 - 127	Indexing
			128 - 189	Clockwise, fast to slow
			190 - 193	No rotation
			194 - 255	Counter-clockwise, slow to fast
9	11	11		<b>Shutter, Strobe</b>
			000 - 031	No function (shutter closed)
			032 - 063	Shutter open
			064 - 095	Strobe, slow to fast
			096 - 127	Shutter open
			128 - 159	Pulse effect, slow to fast
			160 - 191	Shutter open
			192 - 223	Random strobe, slow to fast
224 - 255	Shutter open			
10	12	12	000 - 255	<b>Dimmer Intensity</b> , 0% to 100%
		13	000 - 255	<b>Dimmer Fine</b> , 0% to 100%
11	13	14		<b>Prism 1</b>
			000 - 031	Open
			032 - 255	6 facet prism
12	14	15		<b>Prism 1 Indexing and Rotation</b>
			000 - 127	Indexing
			128 - 189	Clockwise, fast to slow
			190 - 193	No rotation
			194 - 255	Counter-clockwise, slow to fast
		16	000 - 255	<b>Prism 1 Fine Indexing</b>
13	15	17		<b>Prism 2</b>
			000 - 031	Open
			032 - 255	5 Linear Prism
14	16	18		<b>Prism 2 Indexing and Rotation</b>
			000 - 127	Indexing
			128 - 189	Clockwise, fast to slow
			190 - 193	No rotation
			194 - 255	Counter-clockwise, slow to fast
		19	000 - 255	<b>Prism 2 Fine Indexing</b>
15	17	20	000 - 255	<b>Focus Adjustment</b> , far to near
16	18	21	000 - 255	<b>Zoom</b> , minimum to maximum beam angle

CONTINUED ON NEXT PAGE

# DMX TRAITS

CHANNEL			DMX VALUES	FUNCTION
BASIC	STANDARD	EXT		
		22	000 - 255	<b><i>Zoom Fine Indexing</i></b>
17	19	23		<b><i>Iris</i></b>
			000 - 191	Indexing
			192 - 223	Pulse Open, slow to fast
			224 - 255	Pulse Close, fast to slow
18	20	24	000 - 255	<b><i>Frost Filter 1</i></b> , 0% to 100%
19	21	25	000 - 255	<b><i>Frost Filter 2</i></b> , 0% to 100%
	22	26		<b><i>Dim Modes</i></b>
			000 - 020	Standard
			021 - 040	Stage
			041 - 060	TV
			061 - 080	Architectural
			081 - 100	Theatre
			101 - 120	Stage 2
				<b><i>Dimming Speed</i></b>
			121	0.1 s
			122	0.2 s
			123	0.3 s
			124	0.4 s
			125	0.5 s
			126	0.6 s
			127	0.7 s
			128	0.8 s
			129	0.9 s
			130	1.0 s
			131	1.5 s
			132	2.0 s
			133	3.0 s
			134	4.0 s
			135	5.0 s
			136	6.0 s
137	7.0 s			
138	8.0 s			
139	9.0 s			
140	10.0 s			
141 - 255	Default to unit setting			

CONTINUED ON NEXT PAGE

# DMX TRAITS

CHANNEL			DMX VALUES	FUNCTION
BASIC	STANDARD	EXT		
	23	27		<b><i>Dim Curves</i></b>
			000 - 020	Linear
			021 - 040	Square
			041 - 060	Inv. Squa
			061 - 080	S. Curve
			081 - 255	No function
20	24	28	000 - 255	<b><i>Pan/Tilt Speed</i></b> , maximum to minimum
21	25	29		<b><i>LED Refresh Rate</i></b>
			000 - 010	Default LED Refresh Rate
			011	900 Hz
			012	910 Hz
			013	920 Hz
			014	930 Hz
			015	940 Hz
			016	950 Hz
			017	960 Hz
			018	970 Hz
			019	980 Hz
			020	990 Hz
			021	1000 Hz
			022	1010 Hz
			023	1020 Hz
			024	1030 Hz
			025	1040 Hz
			026	1050 Hz
			027	1060 Hz
			028	1070 Hz
			029	1080 Hz
030	1090 Hz			
031	1100 Hz			
032	1110 Hz			
033	1120 Hz			
034	1130 Hz			
035	1140 Hz			
036	1150 Hz			
037	1160 Hz			

CONTINUED ON NEXT PAGE

# DMX TRAITS

CHANNEL			DMX VALUES	FUNCTION
BASIC	STANDARD	EXT		
21	25	29		<i>LED Refresh Rate (continued)</i>
			038	1170 Hz
			039	1180 Hz
			040	1190 Hz
			041	1210 Hz
			042	1220 Hz
			043	1230 Hz
			044	1240 Hz
			045	1250 Hz
			046	1260 Hz
			047	1270 Hz
			048	1280 Hz
			049	1290 Hz
			050	1300 Hz
			051	1310 Hz
			052	1320 Hz
			053	1330 Hz
			054	1340 Hz
			055	1350 Hz
			056	1360 Hz
			057	1370 Hz
			058	1380 Hz
			059	1390 Hz
			060	1400 Hz
			061	1410 Hz
			062	1420 Hz
			063	1430 Hz
			064	1440 Hz
			065	1450 Hz
			066	1460 Hz
			067	1470 Hz
			068	1480 Hz
			069	1490 Hz
			070	1500 Hz
			071	2500 Hz
072	4000 Hz			

CONTINUED ON NEXT PAGE

# DMX TRAITS

CHANNEL			DMX VALUES	FUNCTION
BASIC	STANDARD	EXT		
21	25	29		<b><i>LED Refresh Rate (continued)</i></b>
			073	5000 Hz
			074	6000 Hz
			075	10,000 Hz
			076	15,000 Hz
			077	20,000 Hz
			078	25,000 Hz
			079	Disable LED Refresh Rate
				<b><i>Function</i></b>
			080 - 089	Enable blackout while pan/tilt moving
			090 - 099	Disable blackout while pan/tilt moving
			100 - 109	Enable blackout while color changing
			110 - 119	Disable blackout while color changing
			120 - 129	Enable blackout while gobo changing
			130 - 139	Disable blackout while gobo changing
				<b><i>Reset</i></b>
			140 - 149	Reset All
			150 - 159	Reset Pan/Tilt
			160 - 169	Reset Color and Gobo
			170 - 179	Reset Effects and Focus
				<b><i>Internal Programs</i></b>
			180 - 185	Internal Program 1 (Scenes 1-8)
			186 - 191	Internal Program 2 (Scenes 9-16)
			192 - 197	Internal Program 3 (Scenes 17-24)
			198 - 199	Internal Program 4 (Scenes 25-32)
200 - 205	Internal Program 5 (Scenes 33-40)			
206 - 211	Internal Program 6 (Scenes 41-48)			
212 - 216	Internal Program 7 (Scenes 49-56)			
	<b><i>Fan Modes</i></b>			
217 - 227	Fan Mode Low			
228 - 238	Fan Mode High			
239 - 249	Fan Mode Auto			
250 - 255	No Function			

# SYSTEM MENU

## CONTROL PANEL

The fixture includes an easy to navigate system menu control panel display where all necessary settings and adjustments can be made. See image below for reference. During normal operation, pressing the MENU button once will access the fixture's main menu. Once in the main menu, you can navigate through the different functions and access the sub-menus with the UP and DOWN buttons. When you reach a field that requires adjusting, press the ENTER button to access that field and use the UP and DOWN buttons to adjust the field. Pressing the ENTER button once more will confirm your setting. You may exit the main menu at any time without making any adjustments by pressing the MENU button.

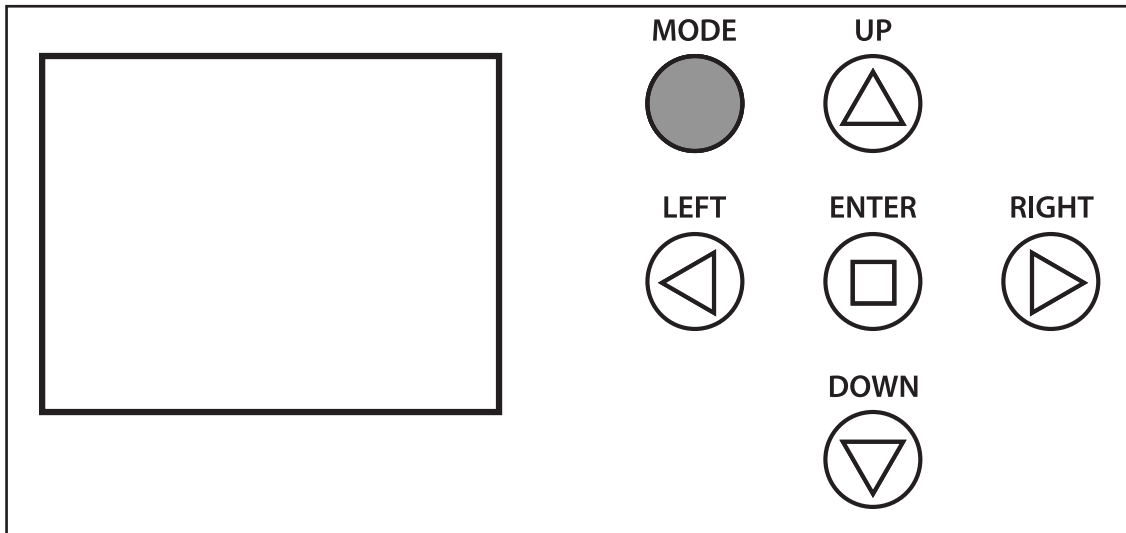

## LCD CONTROL PANEL LOCKOUT

When the Key Lock function is activated, the control panel will automatically lock after the time set under the Display submenu "Screen Saver Delay".

When the Key Lock function is set to ON, the control panel will lock. Press and hold the MODE button for 3 seconds to unlock.

When the Key Lock function is set to ON1, the control panel will lock, and will require a code to unlock. To unlock the display, press UP, DOWN, UP, DOWN, ENTER in that order. If the button sequence was entered correctly, the display and control panel will unlock. Otherwise, the display will revert to displaying the DMX address.

# SYSTEM MENU

<b>DMX SETTINGS</b>	Set Address	<b>A001</b> - Axxx			
	DMX Channel Mode	Basic (21-ch)			
		Standard (25-ch)			
		Extended (29-ch)			
	No DMX Status	<b>Hold Last</b>			
		Blackout			
Manual					
<b>PERSONALITY</b>	Primary	On / Off			
	Secondary	On / Off			
	Status Settings	Pan Degree	<b>540</b> / 630		
		Pan Invert	On / <b>Off</b>		
		Tilt Invert	On / <b>Off</b>		
		P/T Feedback	<b>On</b> / Off		
		P/T Speed	<b>Speed 1</b>		
			Speed 2		
		Hibernation	Off, 01-99 min		Default = <b>15 min</b>
	Fixture ID	Service PIN	Password = 050		
		Universe	000 - 255		
		Unit IP Addr			
		Mask Addr			
	Protocol Set	<b>ArtNet</b>			
		sACN			
	Net Switch	<b>On</b> / Off			
	Fan Settings	Head	<b>Auto</b>		
			High		
			Silent		
	Dim Modes	Standard			
		Stage			
TV					
Architectural					
Theatre					
Stage 2					
Dim Speed		0.1s - 10s			
LED Refresh Rate	900 - 1500 Hz, 2500 Hz, 4000 Hz, 5000 Hz, 6000 Hz, 10 KHz, 15 KHz, 20 KHz, 25 KHz		Default = <b>10 KHz</b>		

CONTINUED ON NEXT PAGE

# SYSTEM MENU

<b>PERSONALITY (continued)</b>	Gamma	1.0			
		<b>2.0</b>			
		2.2			
		2.4			
		2.6			
		2.8			
	Reset Motors	Reset All Motors	Yes / <b>No</b>		
		Pan/Tilt Reset	Yes / <b>No</b>		
		Effect Reset	Yes / <b>No</b>		
		Shutter Reset	Yes / <b>No</b>		
	Display	Intensity	1 - <b>10</b>		
		Display Invert	Yes / <b>No</b>		
		Screen Saver Delay	Off - 10min		
		Key Lock	Off / On		
	Service	Effect Adjust	Pan, Tilt, Color Wheel 1, Color Wheel 2..., Zoom, Iris, Frost1, Frost2		
		USB Port Power	On / <b>Off</b>		
Update Software		Yes / <b>No</b>			
Factory Restore		Yes / <b>No</b>		Passcode = 011	
<b>MANUAL CONTROL</b>	Pan	000 - 255			
	Pan Fine	000 - 255			
	Tilt	000 - 255			
	Tilt Fine	000 - 255			
	...	...			
	P/T Speed	000 - 255			
	Special Function	000 - 255			
<b>INTERNAL PROGRAMS</b>	Program 1	Speed	000 - 255		
		Fade	000 - 255		
	Program 2	Speed	000 - 255		
		Fade	000 - 255		
	Program 3	Speed	000 - 255		
		Fade	000 - 255		
	Program 4	Speed	000 - 255		
		Fade	000 - 255		
	Program 5	Speed	000 - 255		
		Fade	000 - 255		
CONTINUED ON NEXT PAGE					

# SYSTEM MENU

<b>INTERNAL PROGRAMS (continued)</b>	Program 6	Speed	000 - 255	
		Fade	000 - 255	
	Program 7	Speed	000 - 255	
		Fade	000 - 255	
<b>INFORMATION</b>	Fixture Life Time	Power On Time		Lifetime fixture run time, non resettable.
		P-On Time-R		Fixture run time since last reset.
		P-On Time Reset	Passcode = 050	Reset fixture run time.
	Total LED Time	LED On Time		Lifetime LED run time, non-resettable.
		LED On Resettable Time		LED run time since last reset.
		LED Hours Reset	Passcode = 050	Reset LED run time.
	Fixture Temps	LEDs	Current	
			Max Resettable	
			Max Not Resettable	
		Reset LED Temp	Yes / No	Passcode = 050
	Fan Info	LED Fan		
	DMX Values	Pan		Display current DMX value of selected channel.
		Tilt		
		...		
		Special Function		
	Error Logs	Fixture Errors		Displays errors one at a time.
Reset Error Log		Yes / No	Passcode = 050	
Software Version	x.x.x			

## PRIMARY-SECONDARY SET UP

This function allows you to link units together to run in a Primary-Secondary set-up, in which one unit will act as the controlling unit and the others will react to the controlling unit's built-in programs. Any unit can be configured to act as a Primary or as a Secondary, but only one unit in a given system can be programmed to act as the Primary.

### ***Primary-Secondary Connections and Settings:***

1. Daisy chain your units via the XLR connectors on the rear panels of each unit. Use standard XLR data cables to link your units together. Remember that the male XLR connector is the input and the female XLR connector is the output. The first unit in the chain (primary) will use the female XLR connector only. The last unit in the chain will use the male XLR connector only.
2. Primary Unit: Use the display screen and control panel to navigate to Personality > Primary. Select this sub-menu using the ENTER button, and use the arrows to toggle between ON and OFF. Press ENTER to confirm your selection.
3. Secondary Unit(s): Use the display screen and control panel to navigate to Personality > Secondary. Select this sub-menu using the ENTER button, and use the arrows to toggle between ON and OFF. Press ENTER to confirm your selection. Repeat this step for all units that will operate in the slave mode setting.
4. The secondary units will now follow the behavior of the primary unit.

# DIMMER MODES

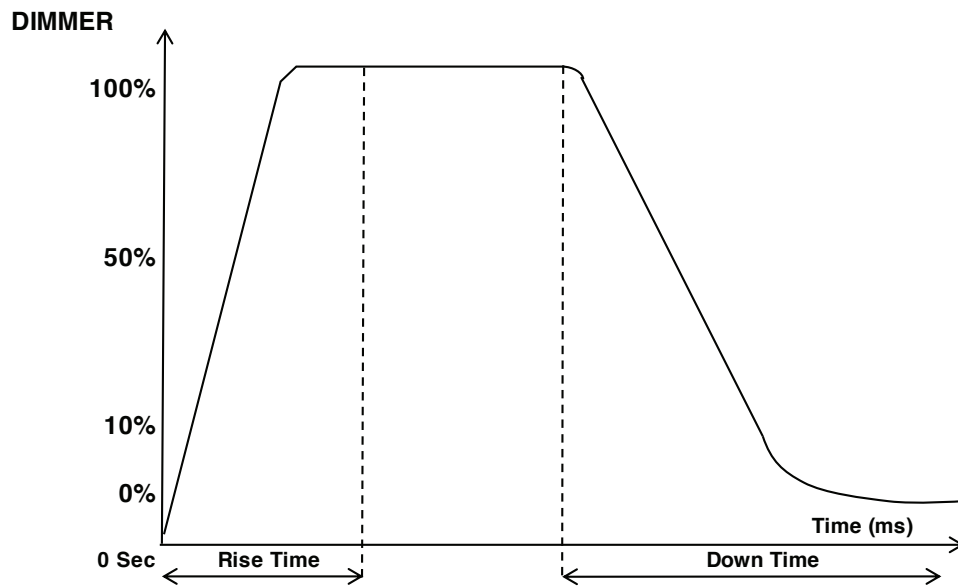

Dimming Curve Ramp Effect	0 sec Fade Time		1 sec Fade Time	
	Rise Time (ms)	Down Time (ms)	Rise Time (ms)	Down Time (ms)
Standard (default)	0	0	0	0
Stage	780	1100	1540	1660
TV	1180	1520	1860	1940
Architectural	1380	1730	2040	2120
Theatre	1580	1940	2230	2280
Stage 2	0	1100	0	1660

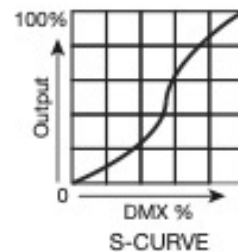
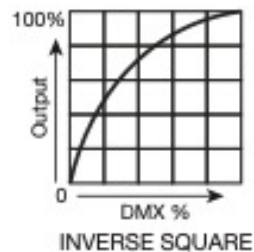
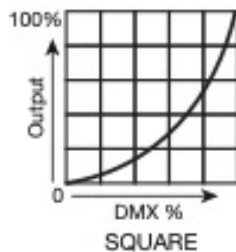
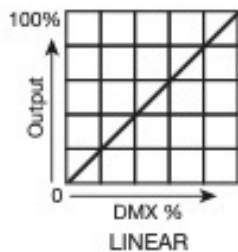

## GOBO REPLACEMENT

This unit features interchangeable gobos. Proceed with caution when changing gobos, as gobos are fragile and can be easily bent, scratched, or otherwise damaged.

**Caution! Never open the unit when in use. Always disconnect the main power before attempting to change the gobos.**

1. Engage both the pan and tilt locks. Unscrew the four (4) screws that secure the cover to the head, then remove the safety clip that attaches near the bottom of the head and remove the cover.



2. Locate the gobo wheels and color wheels. They are positioned near the second large silver thumb screw on each side of the head. Turn the color wheel to that the open slot is facing towards you, and then turn the gobo wheel until the gobo you wish to replace is aligned with the open slot of the color wheel.

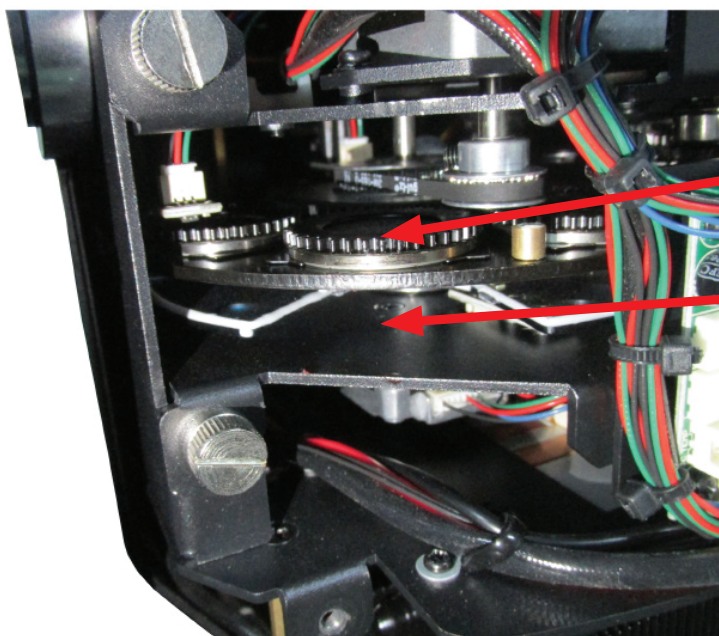

**Gobo being changed is aligned to open slot in color wheel**

**Open slot in color wheel pointing towards user**

## GOBO REPLACEMENT

3. Gently push the gobo holder upwards from below (left). When the silver part of the gobo holder clears the face of the gobo wheel, gently grasp the black geared portion of the gobo holder with your fingers and pull the gobo holder away from the gobo wheel (right). The gobo holder should come away easily. **DO NOT USE EXCESSIVE FORCE WHEN PERFORMING THIS STEP!**

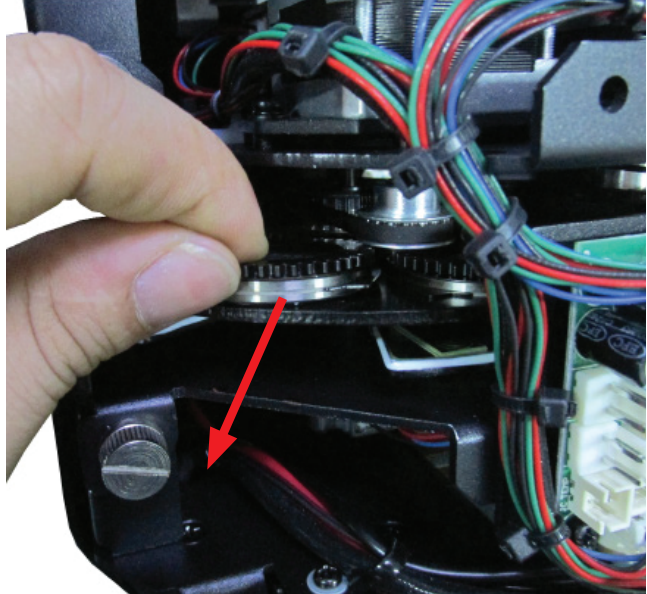
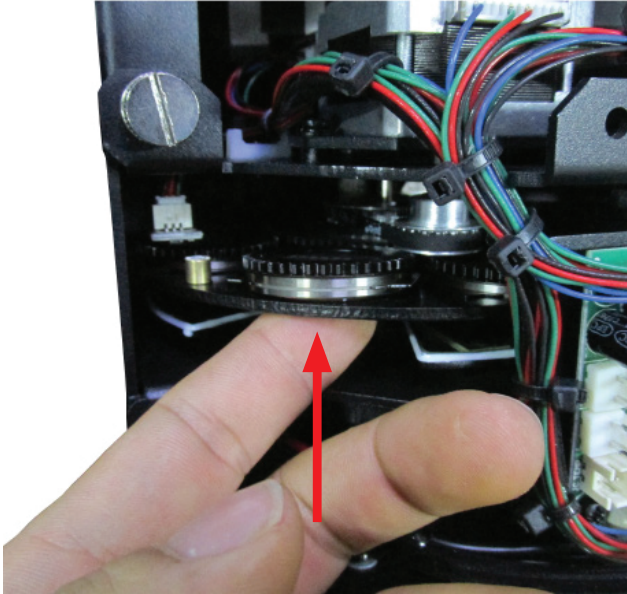

4. Place the gobo holder with the black gear side down. Using a set of tweezers, remove the retaining spring by grasping the end of the spring with the bent tip (right).



**BENT TIP OF SPRING**



5. Remove both the retaining spring and the gobo from the gobo holder.



## GOBO REPLACEMENT

- Place the new gobo in the gobo holder with the black side facing downward. Re-install the retaining spring with the un-bent end of the spring in contact with the gobo.

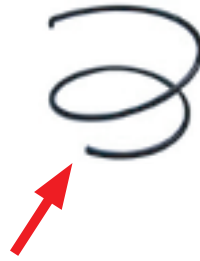

**UN-BENT TIP OF SPRING**

- Turn the gobo holder over so that the black geared side is facing you. Rotate the geared portion of the gobo holder until the mark on the face of the geared portion is aligned with the clip of the gobo holder.

**MARK ON GEARED PORTION ALIGNED WITH CLIP**

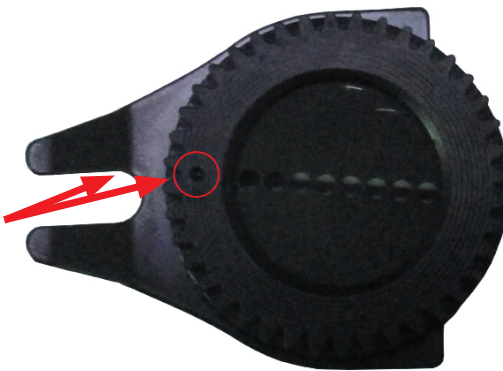

- Locate the large gear on the gobo wheel that meshes with the geared parts of the gobo holders. Rotate the gobo wheel to turn this large gear until the small, circular magnet on this large gear is pointing outwards.

**LARGE GOBO WHEEL GEAR**

**MAGNET**

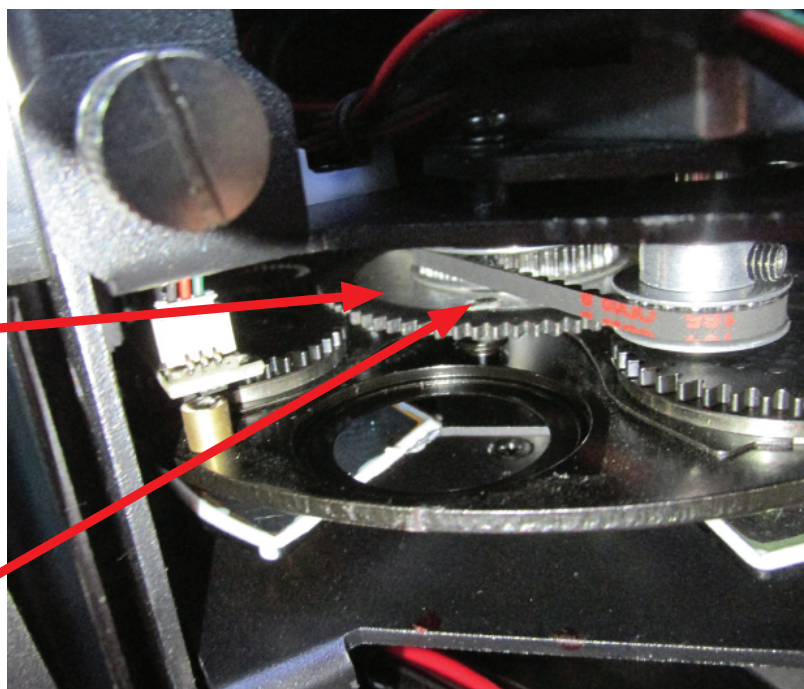

## GOBO REPLACEMENT

9. Making sure that the mark on the geared portion of the gobo holder is still aligned with the gobo holder clip, insert the clip of the gobo holder onto the attachment point on the gobo wheel. You should hear an audible click as the gobo holder snaps into place.

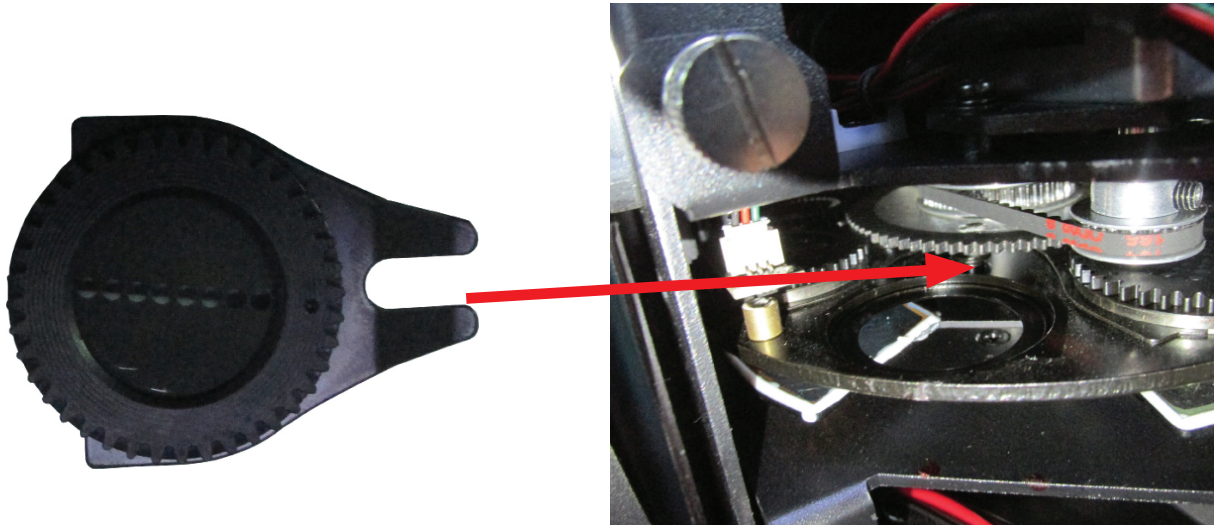

10. Gently push the gobo holder upwards from below, until the silver portion of the gobo holder clears the surface of the gobo wheel. Hold the gobo holder in this position and rotate the gobo holder so that the mark on the black geared portion is aligned with the small circular magnet on the large gobo wheel gear.

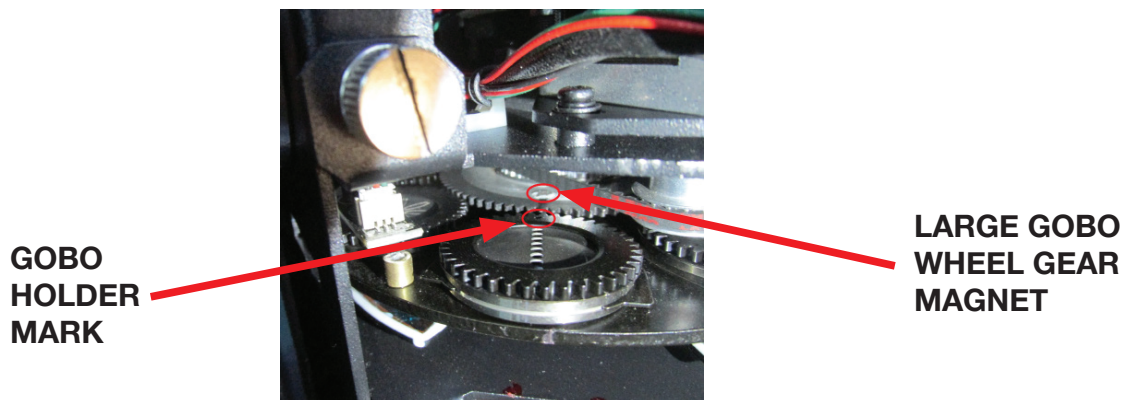

11. Re-attached the safety clip from the cover to the attachment point at the base of the head. Put the cover back in place and tighten the four (4) screws to secure the cover in place.
12. Power the fixture on. Calibrate the newly installed gobo by going to the following location: **Personality > Service > Effect Adjust**. Select the gobo that was just replaced to calibrate. "Gobo1Rot1" represents Gobo Wheel 1, Gobo 1 Rotation; "Gobo1Rot2" represents Gobo Wheel 1, Gobo 2 Rotation, etc. Refer to the Gobos section for the assigned value of each gobo as installed by the factory.

# GOBOS

GOBO WHEEL 1

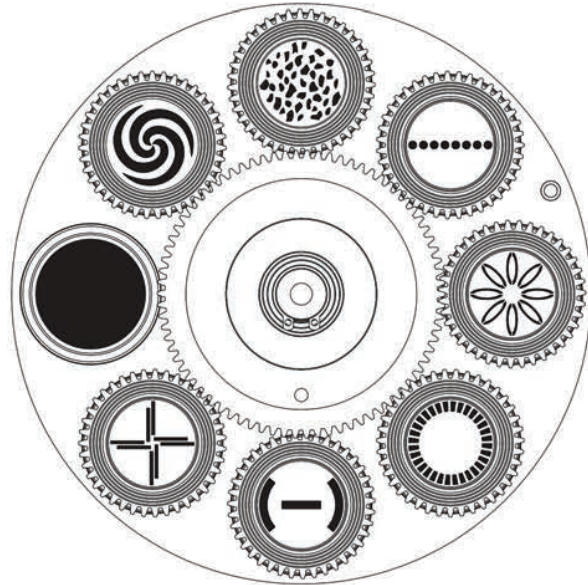

GOBO1



GOBO2

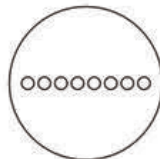

GOBO3



GOBO4



GOBO5

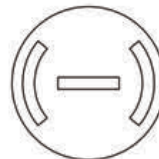

GOBO6



GOBO7

GOBO WHEEL 2



GOBO1



GOBO2



GOBO3



GOBO4



GOBO5



GOBO6



GOBO7

# COLOR WHEELS

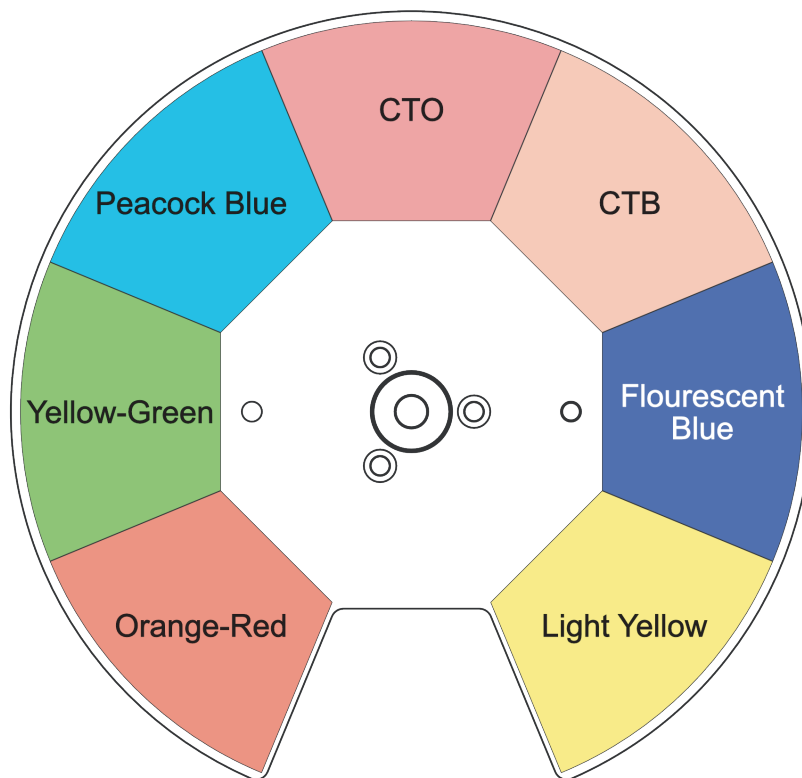

**COLOR WHEEL 1**

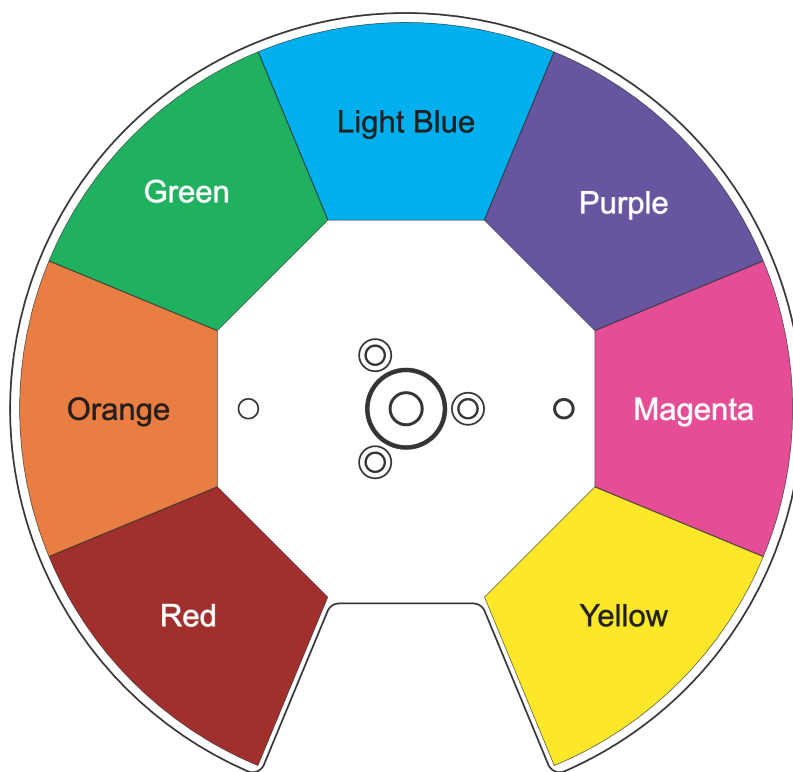

**COLOR WHEEL 2**

## MULTI UNIT POWER LINKING

With this feature you can connect the fixtures to one another using the power cable input and output sockets.

***NOTE: USE CAUTION WHEN POWER LINKING OTHER FIXTURES AS THE POWER CONSUMPTION OF OTHER MODEL FIXTURES MAY EXCEED THE MAX POWER OUTPUT ON THIS FIXTURE! CHECK SILK SCREEN FOR MAX AMPS.***

## TROUBLE SHOOTING

Listed below is a common problem that the user may encounter, with solutions.

### ***Unit not responding to DMX:***

Check that the DMX cables are connected and wired correctly. Also, check that all cables are connected to the right connectors, as connecting the inputs and outputs in the correct order is crucial for proper operation.

## CLEANING

Due to fog residue, smoke, and dust, cleaning the internal and external optical lenses must be carried out periodically to optimize light output.

- Use normal glass cleaner and a soft cloth to wipe down the outside casing.
- Clean the external optics with glass cleaner and a soft cloth every 20 days.
- Always be sure to dry all parts completely before plugging the unit back in.
- Cleaning frequency depends on the environment in which the fixture operates. Heavy exposure to smoke, fog residue, dust, dew, etc. may mean that more frequent cleaning is required.

## SOFTWARE UPDATES

**ONLY QUALIFIED TECHNICIANS SHOULD PERFORM THIS FUNCTION! NOTE ALL MENU SETTINGS BEFORE UPDATING SOFTWARE!**

**FIXTURE SOFTWARE CAN NOT BE DOWNGRADED!**

**DOWNLOAD FIXTURE SOFTWARE TO PC ONLY! (NO MAC SUPPORT) PLEASE CONTACT ADJ CUSTOMER SERVICE FOR FURTHER INFORMATION.**

1. Contact ADJ customer service to obtain the updated software, and download the software to a USB flash drive. In order to minimize the risk of downloading the incorrect software to your device, make sure that the desired update files are the only files on the USB flash drive.
2. Disconnect any DMX connections from your device. Insert the USB flash drive into the service port on your device.
3. Use the display screen control panel to navigate to Personality > Service > USB Port Power. See the **System Menu** section of this manual for detailed instructions. Enter the passcode when prompted, and switch the USB Port Power setting to ON.
4. Highlight the desired file and press ENTER to select it and begin the download.
5. The unit will then update, run an automatic software check, and reset. This may take some time.
6. Repeat this process for each software update file.
7. Verify by navigating to Information > Software Version and confirming that the correct software version number is shown there. See the **System Menu** section of this manual for detailed instructions.

## DIMENSIONAL DRAWINGS

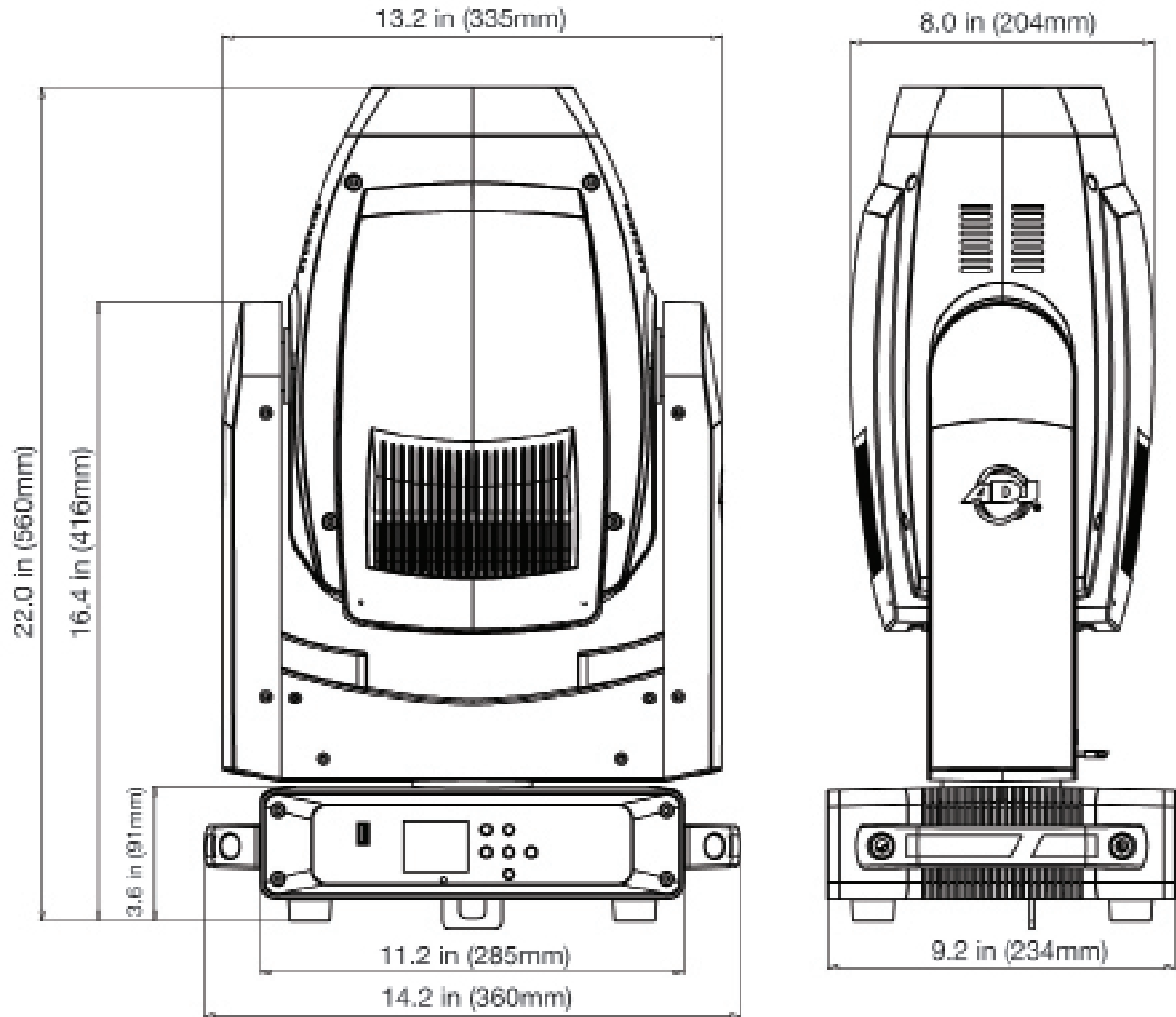

**Drawings may not be shown to scale.**

# SPECIFICATIONS

## Light Source:

- 300W Cool White LED Engine (50,000 hr.)

## Features:

- Motorized Focus
- 2 Frost Filter to create wash effects
- Motorized Zoom: 9~28-degrees
- 2 Prism FX: Rotating 6-facet Linear & rotating 6-facet Circular
- Motorized Iris
- GOBO Morphing
- 0-100% smooth dimming
- Various strobe speeds
- USB firmware update port
- (2) Two Focus Spot 6Z fit inside the DRC MHX road case

## Color Wheels:

- Color Wheel 1: 7 dichroic colors + white
- Color Wheel 2: 7 dichroic colors (includes CTO & CTB)

## GOBO Wheels:

- GOBO Wheel 1: 7 GOBOS + open
- GOBO Wheel 2: 7 GOBOS + open
- GOBO Morphing
- GOBO Shake Effect
- Metal GOBO Size: 23mm (outer), 19mm (viewable), 0.5mm (thickness)
- Glass GOBO Size: 23mm (outer), 19mm (viewable), 1.6mm (thickness)

## Prism Wheel:

- Prism Wheel 1: Rotatable 6-facet Linear
- Prism Wheel 2: Rotatable 6-facet Circular
- Each Prism is indexable

## Frost Filters:

- Frost 1: Heavy frost for wash effect
- Frost 2: Light frost creates lightly blurred edges for GOBO and Prism FX

## Control:

- 3 DMX Channel Modes: 21/25/29 Channels
- Color LCD display with 6-button function menu
- Control Mode: DMX512 or internal programs
- 6 Dimming Curve Modes: Standard, Stage, TV, Architectural, Theatre, Stage 2
- 0-100% smooth dimming
- Various strobe speeds
- USB firmware update port
- With Wired Digital Communication Network
- RDM (Remote Device Management)

## Pan/Tilt:

- Pan: 540/630 degrees
- Tilt: 270 degrees
- 16-bit fine pan & tilt
- Pan & Tilt locks

## Connections:

- DMX Connections: 3-pin & 5-pin XLR In/Out
- Power Connections: PowerLock In/Out to daisy chain power
- RJ45 In/Out connections for Art-Net & sACN control

## Electrical:

- Multi-voltage operation: AC 90-240V, 50/60Hz
- Max power consumption: 380W

## Dimensions & Weight:

- Dimensions (LxWxH): 14.18" x 9.21" x 22.04" / 360 x 234 x 560mm
- Weight: 42.4 lbs. / 19.4 kg

## Approvals/Ratings:

- ETL Approved I CE Certified



*Please Note: Specifications and improvements in the design of this unit and this manual are subject to change without any prior written notice.*



