

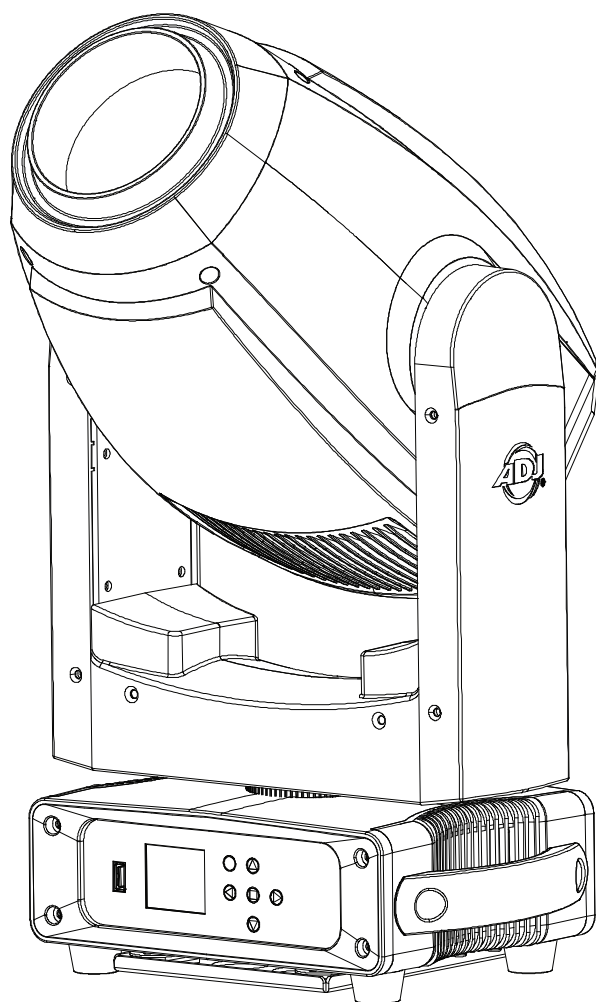

FOCUS HYBRID



User Manual

©2022 ADJ Products, LLC all rights reserved. Information, specifications, diagrams, images, and instructions herein are subject to change without notice. ADJ Products, LLC logo and identifying product names and numbers herein are trademarks of ADJ Products, LLC. Copyright protection claimed includes all forms and matters of copyrightable materials and information now allowed by statutory or judicial law or hereinafter granted. Product names used in this document may be trademarks or registered trademarks of their respective companies and are hereby acknowledged. All non-ADJ Products, LLC brands and product names are trademarks or registered trademarks of their respective companies.

ADJ Products, LLC and all affiliated companies hereby disclaim any and all liabilities for property, equipment, building, and electrical damages, injuries to any persons, and direct or indirect economic loss associated with the use or reliance of any information contained within this document, and/or as a result of the improper, unsafe, insufficient and negligent assembly, installation, rigging, and operation of this product.

DOCUMENT VERSION



Due to additional product features and/or enhancements, an updated version of this document may be available online.

Please check www.adj.com for the latest revision/update of this manual before beginning installation and/or programming.

Date	Document Version	DMX Channels	Notes
09/23/2022	1.0	19 / 23 / 25 ch.	Initial Release
01/30/2023	1.1	N/C	Updated Dimensions/Specs.

Europe Energy Saving Notice

Energy Saving Matters (EuP 2009/125/EC)

Saving electric energy is a key to help protecting the environment. Please turn off all electrical products when they are not in use. To avoid power consumption in idle mode, disconnect all electrical equipment from power when not in use. Thank you!

TABLE OF CONTENTS

Introduction	4
Limited Warranty (USA Only)	5
Warranty Registration Features	6
Safety Precautions	7
Overview	8
Installation	9
Accessory Installation	12
Remote Device Management (RDM)	13
Wifly	14
Color Wheel	15
Gobos	16
Control Panel	19
System Menu	20
DMX Set Up	23
DMX Traits	25
Dim Speeds	33
Dim Modes	34
Primary-Secondary Set Up Multi Unit Power Linking	35
Maintenance Guidelines	36
Error Codes	37
Dimensional Drawings	38
Specifications	39

INTRODUCTION

Unpacking: Thank you for purchasing the Focus Hybrid by ADJ Products, LLC. Every device has been thoroughly tested and has been shipped in perfect operating condition. Carefully check the shipping carton for damage that may have occurred during shipping. If the carton appears to have been damaged, carefully inspect your fixture for any damage and be sure all accessories necessary to operate the unit have arrived intact. In the event that damage has been found or parts are missing, please contact our toll free customer support number for further instructions. Do not return this unit to your dealer without first contacting customer support.

Introduction: ADJ's Focus Hybrid is a professional beam, spot, and wash capable moving head lighting fixture powered by a 200-Watt LED engine. **This product is intended to be used by professionally trained personnel only and is not suitable for private use.**

Customer Support: Contact ADJ Service for any product related service and support needs. Also visit forums.adj.com with questions, comments or suggestions.

Parts: To purchase parts online visit:

<http://parts.adj.com> (US)

<http://www.adjparts.eu> (EU)

ADJ SERVICE USA - Monday - Friday 8:00am to 4:30pm PST

Voice: 800-322-6337 | Fax: 323-582-2941 | support@adj.com

ADJ SERVICE EUROPE - Monday - Friday 08:30 to 17:00 CET

Voice: +31 45 546 85 60 | Fax: +31 45 546 85 96 | support@americandj.eu

ADJ PRODUCTS LLC USA

6122 S. Eastern Ave. Los Angeles, CA. 90040

323-582-2650 | Fax 323-532-2941 | www.adj.com | info@adj.com

ADJ SUPPLY Europe B.V

Junostraat 2 6468 EW Kerkrade, The Netherlands

+31 (0)45 546 85 00 | Fax +31 45 546 85 99

www.americandj.eu | info@americandj.eu

ADJ PRODUCTS GROUP Mexico

AV Santa Ana 30 Parque Industrial Lerma, Lerma, Mexico 52000

+52 (728) 282-7070

CAUTION! To avoid the risk of shock or fire, do NOT expose this unit to rain or moisture! This unit is intended only for dry, indoor environments!

CAUTION! There are no user serviceable parts inside this unit. Do not attempt any repairs yourself, as doing so will void your manufacturer's warranty. In the unlikely event your unit may require service, please contact ADJ Products, LLC.

Do not discard the shipping carton in the trash. Please recycle when ever possible.

LIMITED WARRANTY (USA ONLY)

- A. ADJ Products, LLC hereby warrants, to the original purchaser, ADJ Products, LLC products to be free of manufacturing defects in material and workmanship for a prescribed period from the date of purchase (see specific warranty period on reverse). This warranty shall be valid only if the product is purchased within the United States of America, including possessions and territories. It is the owner's responsibility to establish the date and place of purchase by acceptable evidence, at the time service is sought.
- B. For warranty service, you must obtain a Return Authorization number (RA#) before sending the product back—please contact ADJ Products, LLC Service Department at 800-322-6337. Send the product only to the ADJ Products, LLC factory. All shipping charges must be prepaid. If the requested repairs or service (including parts replacement) are within the terms of this warranty, ADJ Products, LLC will pay return shipping charges only to a designated point within the United States. If the entire instrument is sent, it must be shipped in its original package and packaging material. No accessories should be shipped with the product. If any accessories are shipped with the product, ADJ Products, LLC shall incur no liability whatsoever for loss of or damage to any such accessories, nor for the safe return thereof.
- C. This warranty is void if the product serial number and/or labels are altered or removed; if the product is modified in any manner which ADJ Products, LLC concludes, after inspection, affects the reliability of the product; if the product has been repaired or serviced by anyone other than the ADJ Products, LLC factory unless prior written authorization was issued to purchaser by ADJ Products, LLC; if the product is damaged because it was not properly maintained as set forth in the product instructions, guidelines and/or user manual.
- D. This is not a service contract, and this warranty does not include maintenance, cleaning, or periodic check-up. During the period specified above, ADJ Products, LLC will replace defective parts at its expense with new or refurbished parts, and will absorb all expenses for warranty service and repair labor by reason of defects in material or workmanship. The sole responsibility of ADJ Products, LLC under this warranty shall be limited to the repair of the product, or replacement thereof, including parts, at the sole discretion of ADJ Products, LLC. All products covered by this warranty were manufactured after August 15, 2012, and bear identifying marks to that effect.
- E. ADJ Products, LLC reserves the right to make changes in design and/or improvements upon its products without any obligation to include these changes in any products theretofore manufactured.
- F. No warranty, whether expressed or implied, is given or made with respect to any accessory supplied with products described above. Except to the extent prohibited by applicable law, all implied warranties made by ADJ Products, LLC in connection with this product, including warranties of merchantability or fitness, are limited in duration to the warranty period set forth above. And all warranties, whether expressed or implied, including warranties of merchantability or fitness, are limited in duration to the warranty period set forth above. The consumer's and/or dealer's sole remedy shall be such repair or replacement as is expressly provided above; and under no circumstances shall ADJ Product, LLC be liable for any loss and/or damage, direct and/or consequential arising out of the use of, and/or inability to use this product.
- G. This warranty is the only written warranty applicable to ADJ Products, LLC products, and supersedes all prior warranties and written descriptions of warranty terms and conditions heretofore published.

MANUFACTURER'S LIMITED WARRANTY PERIODS:

- Non-LED Lighting Products = 1-Year (365 Days) (Including Special Effect Lighting, Intelligent Lighting, UV lighting, Strobes, Fog Machines, Bubble Machines, Mirror Balls, Par Cans, Trussing, Lighting Stands, Power/Data Distribution, etc. excluding LED and lamps)
- Laser Products = 1-Year (365 Days) (excluding laser diodes which have a 6-Month Limited Warranty)
- LED Products = 2-Year (730 Days) (excluding batteries which have a 180 Day Limited Warranty)
- NOTE: 2-Year (730 Days) Limited Warranty ONLY applies to product purchased within the United States. StarTec Series = 1-Year (365 Days) (excluding batteries which have a 180 Day Limited Warranty)
- ADJ DMX Controllers = 2 Year (730 Days)
- American Audio Products = 1 Year (365 Days)

WARRANTY REGISTRATION

Please fill out the enclosed warranty card to validate your purchase. All returned service items, whether under warranty or not, must be freight pre-paid and accompanied by a return authorization (R.A.) number. The R.A. number must be clearly written on the outside of the return package. A brief description of the problem as well as the R.A. number must also be written down on a piece of paper included in the shipping carton. If the unit is under warranty, you must provide a copy of your proof of purchase invoice. You may obtain an R.A. number by contacting our customer support team. All packages returned to the service department not displaying an R.A. number on the outside of the package will be returned to the shipper.

FEATURES

- 200W LED Engine
- 8-Facet Circular & 6-Facet Linear Rotating Prisms
- Replaceable Frost Filter (Heavy Frost Default)
- Motorized Zoom (2° to 24°)
- Motorized Focus
- Electronic Dimming & Strobe (1-20Hz)
- Color Wheel with 11 dichroic colors, includes 3200 CTO Filter
- 7 Interchangeable Rotating-Indexing Gobos
- 15 Static Stamped Gobos

INCLUDED ITEMS

- Omega Brackets (x2)
- Medium Frost Filter (x1)
- Locking Power Cable (x1)

SAFETY PRECAUTIONS



PROTECTION CLASS 1 - FIXTURE MUST BE PROPERLY GROUNDED.



THERE ARE NO USER SERVICEABLE PARTS INSIDE THIS UNIT. DO NOT ATTEMPT ANY REPAIRS YOURSELF, AS DOING SO WILL VOID YOUR MANUFACTURER'S WARRANTY. DAMAGES RESULTING FROM MODIFICATIONS TO THIS FIXTURE AND/OR THE DISREGARD OF SAFETY INSTRUCTIONS AND GUIDELINES IN THIS MANUAL VOID THE MANUFACTURER'S WARRANTY AND ARE NOT SUBJECT TO ANY WARRANTY CLAIMS AND/OR REPAIRS.



DO NOT EXPOSE THIS UNIT TO RAIN AND/OR MOISTURE! THIS FIXTURE IS INTENDED FOR USE IN DRY, INDOOR ENVIRONMENTS ONLY!



**NEVER LOOK DIRECTLY INTO THE LIGHT SOURCE!
RETINA INJURY RISK - MAY INDUCE BLINDNESS!
SENSITIVE PERSONS MAY SUFFER AN EPILEPTIC SHOCK!**

- **Maximum ambient operating temperature is 113° F (45° C)!**
- DO NOT TOUCH the fixture housing during operation. Disconnect the power and allow approximately 15 minutes for the fixture to cool down before servicing.
- DO NOT shake the fixture, and avoid brute force when installing and/or operating the fixture.
- DO NOT operate the fixture if the power cord has become frayed, crimped and/or damaged. If the power cord is damaged, replace immediately with a new one of the same power rating.
- DO NOT attempt to remove or break off the ground prong from the electrical cord. This prong is used to reduce the risk of electrical shock and fire in the event of an internal short.
- DO NOT attempt to operate this unit if it has been damaged in any way.
- DO NOT spill water or other liquids into or on to your unit.
- Disconnect from main power before making any type of connection.
- DO NOT block any air ventilation slots. All fan and air inlets must remain clean and never blocked. Allow approx. 6" (15cm) between fixture and other devices or a wall for proper cooling.
- Always be sure to mount this unit in an area that will allow proper ventilation.
- DO NOT remove the cover under for any reason.
- When installing fixture in a suspended environment, always use mounting hardware that is no less than M10 x 25mm, and always install fixture with an appropriately rated safety cable.
- Never plug this unit in to a dimmer pack.
- During long periods of non-use, disconnect the unit's main power.
- Always mount this unit in safe and stable matter.
- Power-supply cords should be routed so that they are not likely to be walked on or pinched by items placed upon or against them, paying particular attention to the point where they exit the unit.
- Cleaning - The fixture should be cleaned only as recommended by the manufacturer.
- Heat - The appliance should be situated away from heat sources such as radiators, heat registers, stoves, or other appliances (including amplifiers) that produce heat.
- The fixture should be serviced by qualified service personnel when:
 - A. The power-supply cord or the plug have been damaged.
 - B. Objects have fallen onto, or liquid has been spilled into, the fixture.
 - C. The fixture does not appear to operate normally or exhibits a marked change in performance.
 - D. The fixture has fallen and/or has been subjected to extreme handling.

OVERVIEW

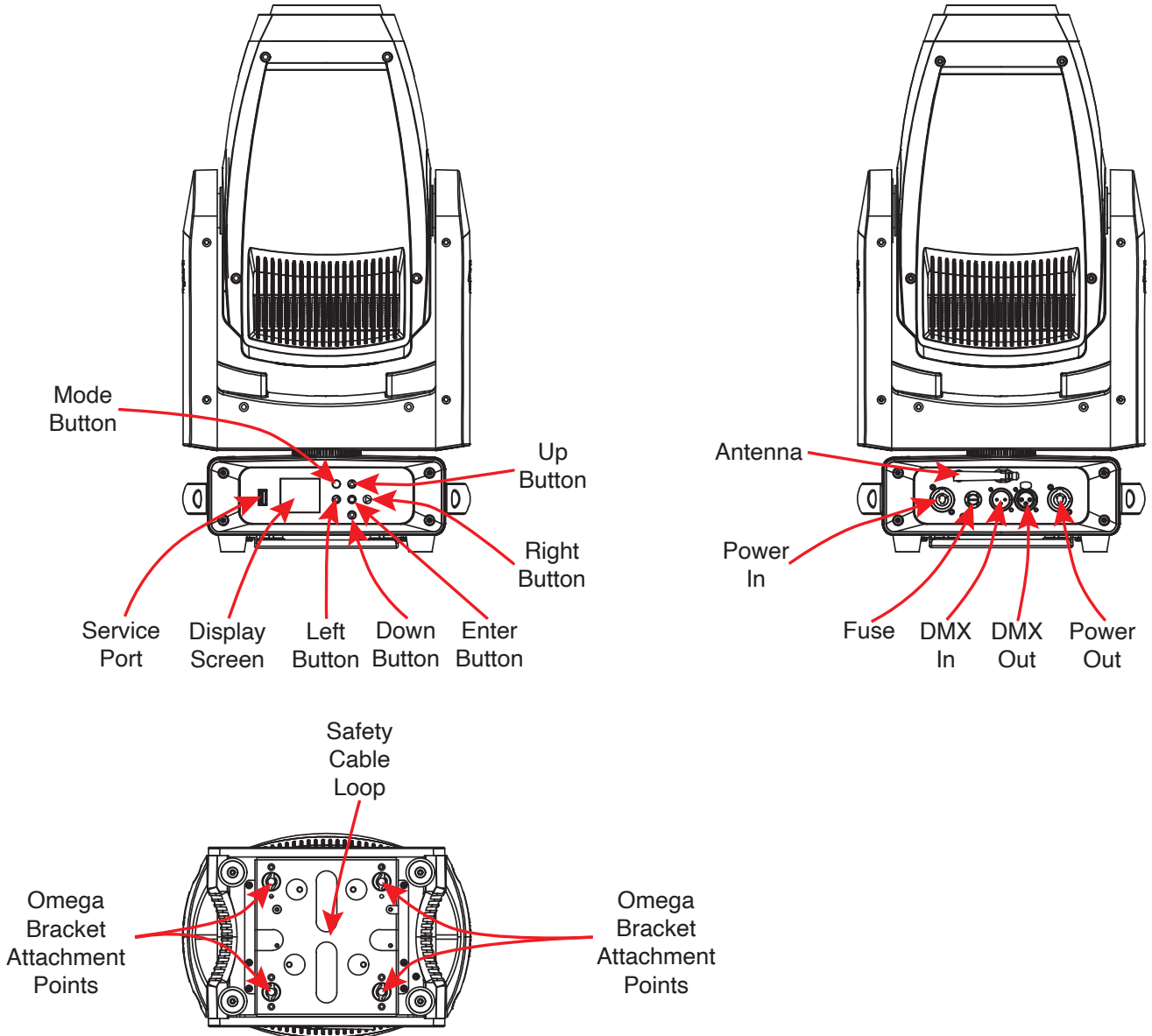

INSTALLATION



DO NOT INSTALL THE FIXTURE IF YOU ARE NOT QUALIFIED TO DO SO!

Fixture **MUST** be installed following all local, national, and country commercial electrical and construction codes and regulations.

When installing the unit, the trussing or area of installation must be able to support at least 10 times the weight of the unit and any attached accessories without any deformation. The unit must be secured with a secondary safety attachment, e.g. an appropriately-rated safety cable.

Before rigging/mounting a fixture to any metal truss/structure or placing the fixture(s) on any surface, a professional equipment installer **MUST** be consulted to determine if the metal truss/structure or surface is properly certified to safely hold the combined weight of the fixture(s), clamps, cables, and accessories.

Maximum ambient operating temperature is **-113° F (45° C)**.

Fixture(s) should be installed away from walking paths, seating areas, or areas where unauthorized personnel might reach the fixture by hand.

NEVER stand directly below the fixture(s) when rigging, removing, or servicing.

Overhead fixture installation must always be secured with a secondary safety attachment, such as an appropriately rated safety cable that can hold at least 10 times the weight of the fixture.

Overhead mounting requires extensive experience, including calculating working load limits, knowledge of installation material being used, and periodic safety inspection of all installation material as well as the unit itself. If you lack these qualifications, do not attempt the installation yourself.

The installation should be checked by a skilled person once a year.

INSTALLATION

CLAMP MOUNTING

This fixture features mounting points on the underside for the attachment of two Omega brackets. Additionally, the unit also features a safety cable loop on the underside, between the Omega bracket mounting points (see the illustration below). When mounting the fixture to a truss or any other suspended or overhead installation, be sure to secure appropriately rated mounting clamps (not included) to each Omega bracket. **Please note that two Omega brackets and two mounting clamps are needed to safely support the fixture in a suspended installation.** Attach a separate **SAFETY CABLE** of the appropriate weight rating to the provided safety cable loop. **NEVER** use carry handles as an attachment point for the safety cable.

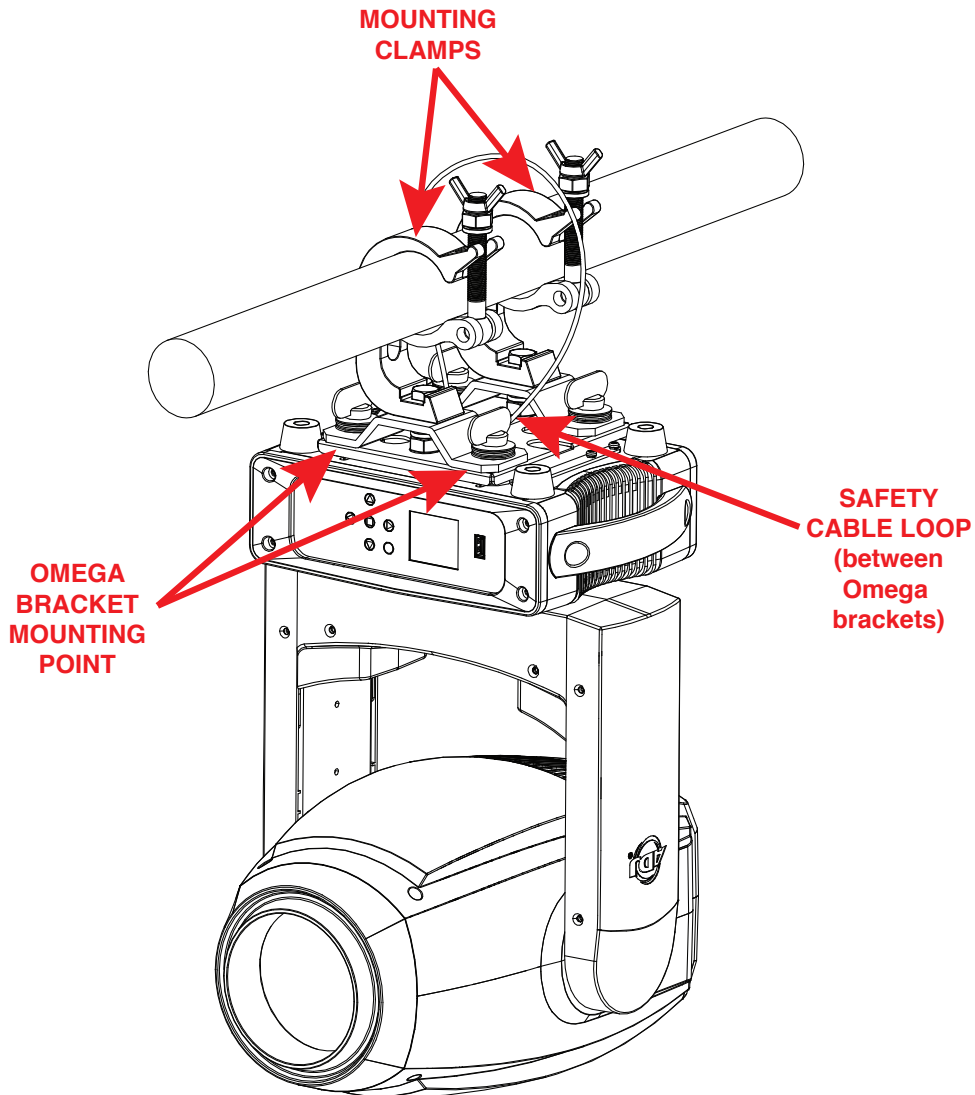

SAFETY CABLE:

ALWAYS ATTACH A SAFETY CABLE WHENEVER INSTALLING THIS FIXTURE IN A SUSPENDED ENVIRONMENT TO ENSURE THAT THE FIXTURE WILL NOT FALL IF THE CLAMP FAILS.



INSTALLATION

POTENTIAL INTERNAL FIXTURE DAMAGE FROM EXTERNAL SOURCES OF LIGHT BEAMS

External sources of light beams from direct sunlight, lighting and moving head fixtures, and lasers, which are focused directly towards the exterior housing and/or penetrate the front lens opening of ADJ lighting fixtures, can cause severe internal damage including burning of optics, dichroic color filters, glass and metal gobos, prisms, animation wheels, frost filters, iris, shutters, motors, belts, wiring, discharge lamps, and LEDs.

This issue is not specific only to ADJ lighting fixtures, but rather it is a common issue with lighting fixtures from all manufacturers. Although there is no true way to fully prevent this issue from happening, the guidelines below can reduce the risk of potential damage. Contact ADJ Service for more details.

DO NOT EXPOSE THE FIXTURE AND/OR FRONT LENS OPENING TO LIGHT BEAMS FROM DIRECT SUNLIGHT, OTHER LIGHTING OR MOVING HEAD FIXTURES, AND LASERS DURING UNPACKING, INSTALLATION, USE, AND EXTENDED IDLE TIMES OUTDOORS. DO NOT FOCUS A LIGHT BEAM FROM ONE LIGHTING FIXTURE DIRECTLY TOWARDS ANOTHER.

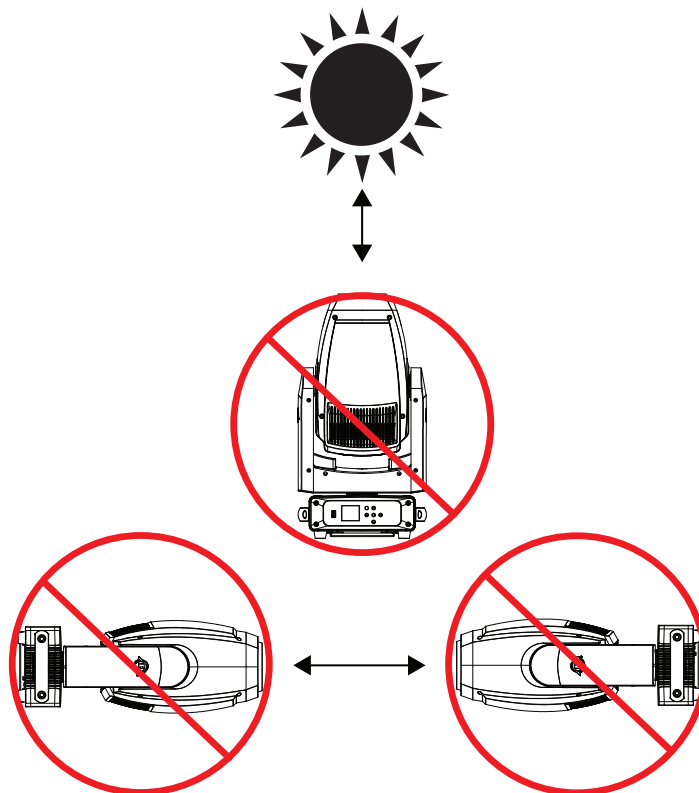

The hibernation function is an existing feature that puts the unit into a 'sleep state' to save power (this is a state where only the electronics remain on, and all other functions are turned off, functions such as motors lamps etc). This state is automatically activated when no DMX signal is present for the set time (1-99min or off). The hibernation feature can be deactivated either from the System Menu or via the DMX channel for Special Functions. Refer to the **System Menu** and **DMX Traits** section of this manual for detailed information.

ACCESSORY INSTALLATION

FROST FILTER

1. Place the device on a flat, stable surface, and allow the device to cool down for at least 1 hour before beginning this procedure.
2. Remove the screws holding the head covers in place, and detach the clips for the head cover security cables. Remove the head covers.
3. Locate the frost filter, which is positioned on the top-most module. Remove the screws that hold the frost filter in place, then remove from the module. Refer to the illustration below.

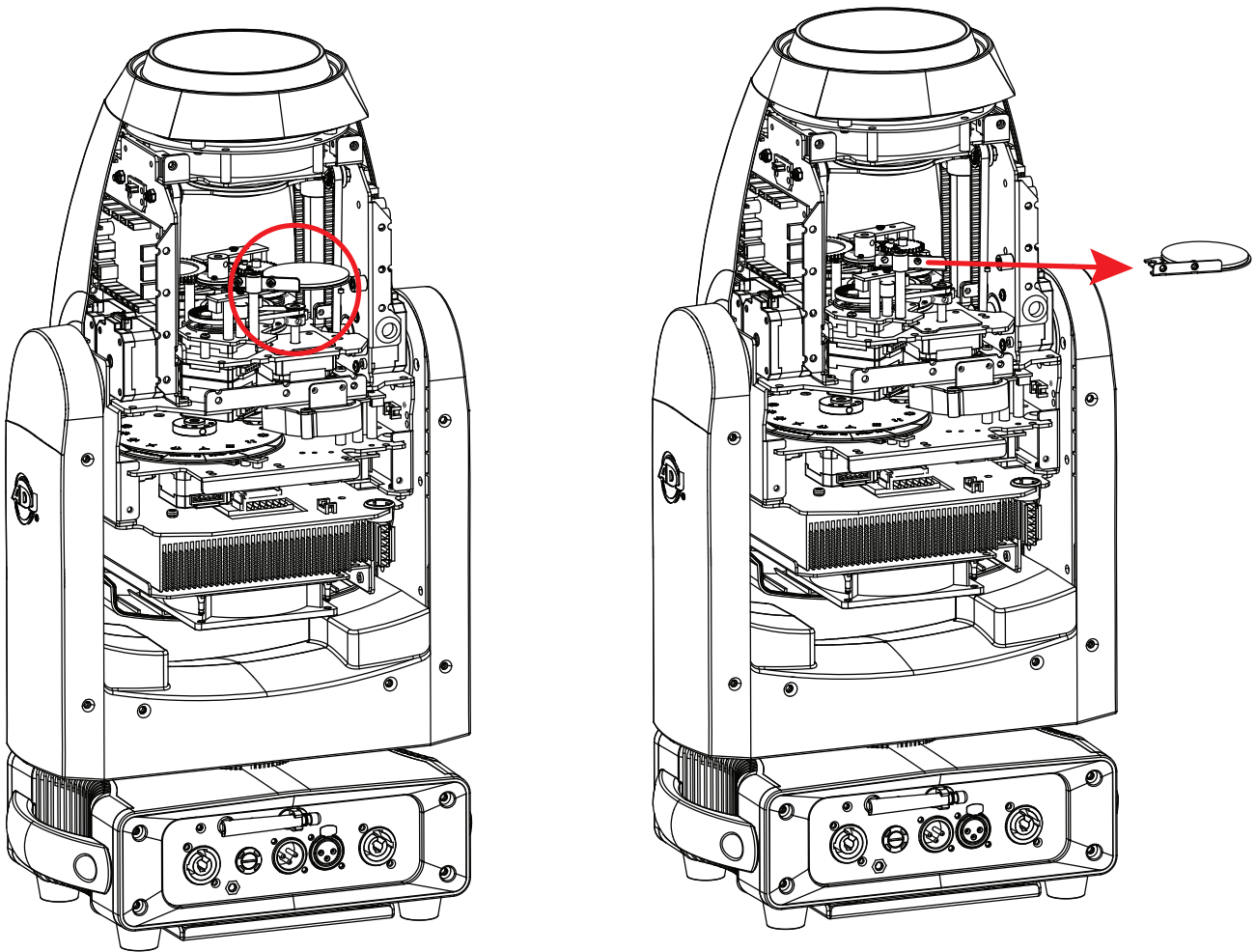

4. Install the new frost filter in place and secure it with the screws that were removed in step 3. Reinstall the head covers.

REMOTE DEVICE MANAGEMENT (RDM)

NOTE: In order for RDM to work properly, RDM enabled equipment must be used throughout the entire system, including DMX data splitters and wireless systems.

Remote Device Management (RDM) is a protocol that sits on top of the DMX512 data standard for lighting, allowing the DMX systems of the fixtures to be modified and monitored remotely. This protocol is ideal for instances in which a unit is installed in a location that is not easily accessible.

With RDM, the DMX512 system becomes bi-directional, allowing a compatible RDM enabled controller to send out a signal to devices on the wire, as well as allowing the fixture to respond (known as a *GET* command). The controller can then use its *SET* command to modify settings that would typically have to be changed or viewed directly via the unit's display screen, including the DMX Address, DMX Channel Mode, and Temperature Sensors.

FIXTURE RDM INFORMATION:

RDM Code	Device ID	Device Model ID	Personality ID
0x1900	002B	43	001: Basic (19) 002: Standard (23) 003 Extended (25)

Please be aware that not all RDM devices support all RDM features, and therefore it is important to check beforehand to ensure that the equipment that you are considering includes all of the features that you require.

The following parameters are accessible in RDM on this device:

[0x0200] Sensor Definition	[0x0500] Display Invert
[0x0201] Sensor Value	[0x0501] Display Level
[0x0080] Device Model Description	[0x0603] Realtime Clock
[0x0081] Manufacturer Label	[0x1010] Power State
[0x0082] Device Label	[0x1031] Preset Playback
[0x00E0] DMX Personality	[0x0120] Slot Information
[0x00E1] DMX Personality Description	[0x0121] Slot Description
[0x0400] Device Hours	[0x0122] Default Slot Value
[0x0015] Comms Status	[0x00B0] Language
[0x0031] Status ID Description	[0x00A0] Language Capabilites
[0x0032] Clear Status ID	[0x00C2] Boot Software Version Label
[0x0405] Device Power Cycles	[0x00C1] Boot Software Version ID
[0x0600] Pan Invert	[0x0070] Product Detail ID List
[0x0601] Tilt Invert	[0x0030] Status Messages
[0x0602] Pan Tilt Swap	

WIFLY

There are many factors that can affect and/or interrupt a wireless signal, including walls, glass, metal, objects, and people. Therefore, the following guidelines are recommended in order to maximize the chances of having a clear path for the wireless signal to reach the device:

- Install the device a minimum of 9.8 ft (3m) above audiences and/or ground level.
- Arrange the wireless antenna in an upright, vertical position.
- Position devices in direct line of sight of the transmitting controller.

Careful planning and testing of the selected installation location is critical to ensure optimum and reliable wireless operation.

9.8 ft (3m)
Above Ground



To enable Wifly, open the system menu and navigate to Personality > Wifly Settings > Enable Wifly, and then use the UP or DOWN button to toggle to the “On” setting.

Various other Wifly settings can be configured from the Personality > Wifly Settings sub-menu, as well. For detailed information, please refer to the **System Menu** section of this manual.

COLOR WHEEL

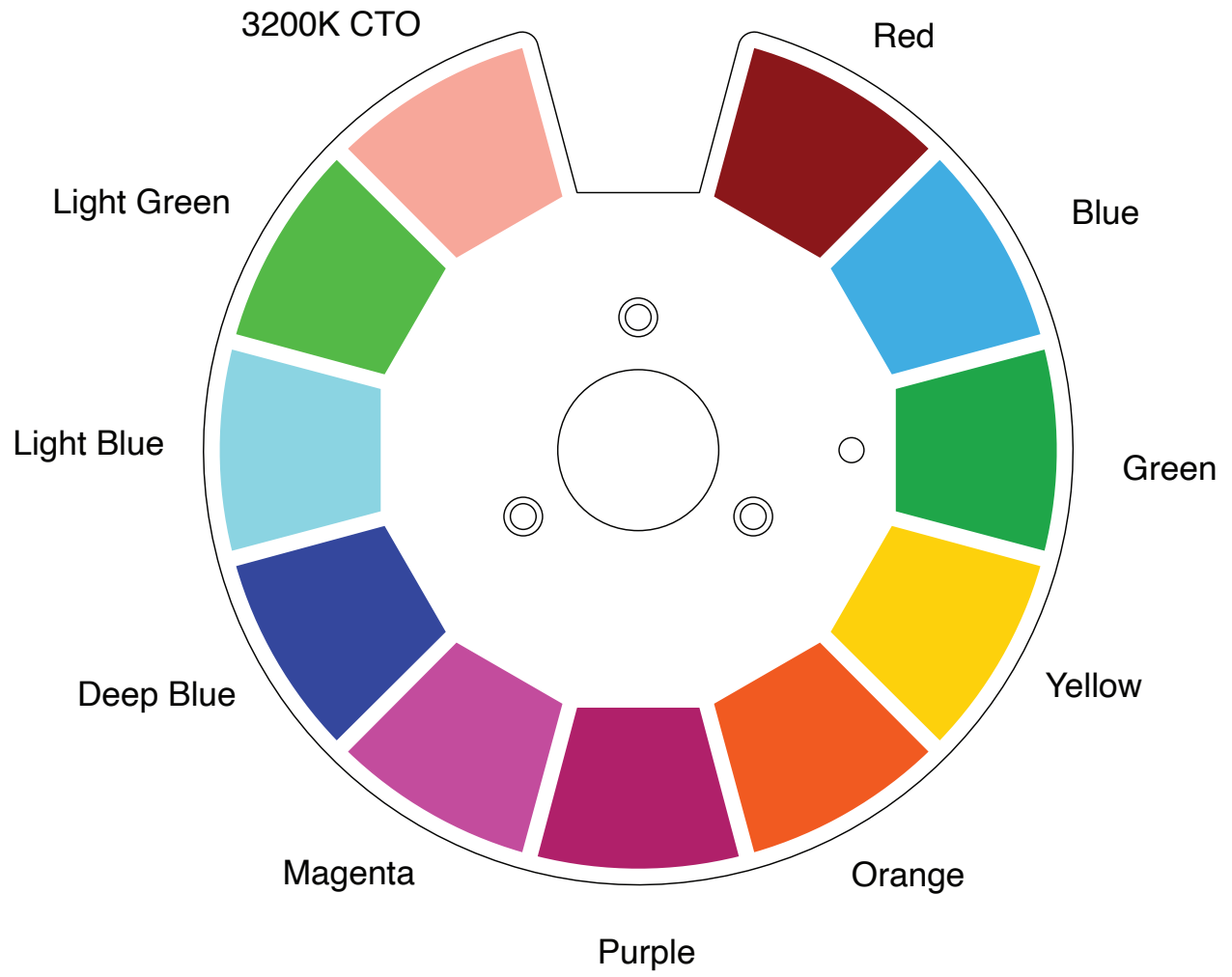

GOBOS

DESIGNS

FIXED GOBOS

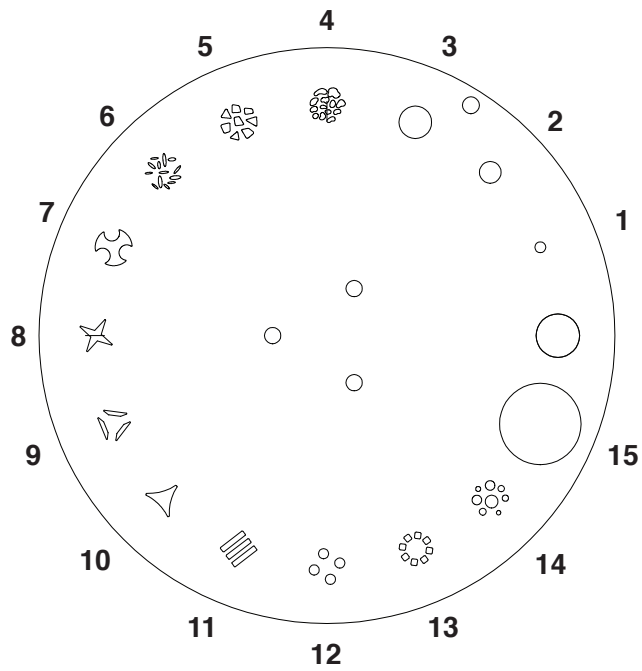

ROTATING GOBOS

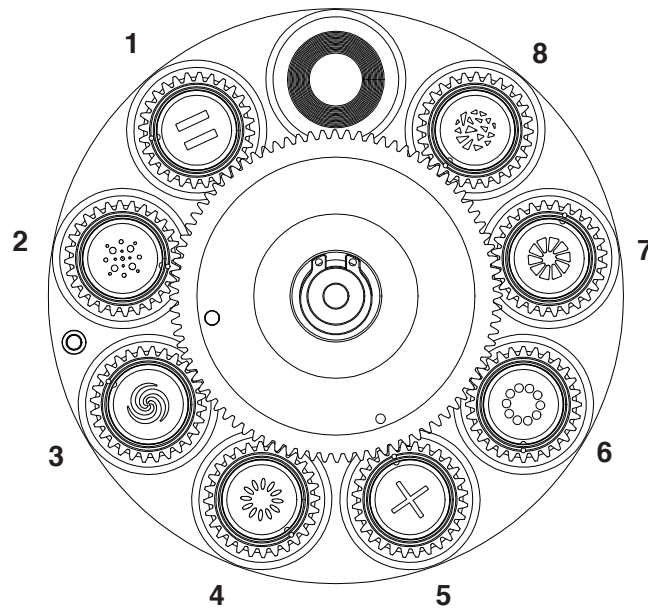

GOBO DIMENSIONS		
Thickness	Inner (Viewable) Diameter	Outer Diameter
0.02in (0.5mm)	0.35in (9.0mm)	0.650in ⁰ _{0.007} (16.5mm ⁰ _{0.2})

GOBOS

GOBO HOLDER DIM DRAWING

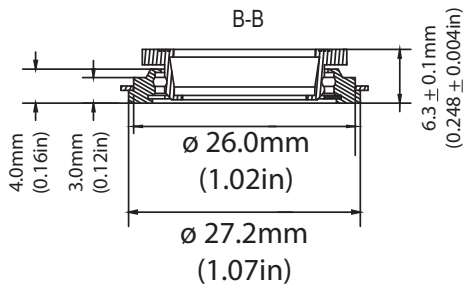
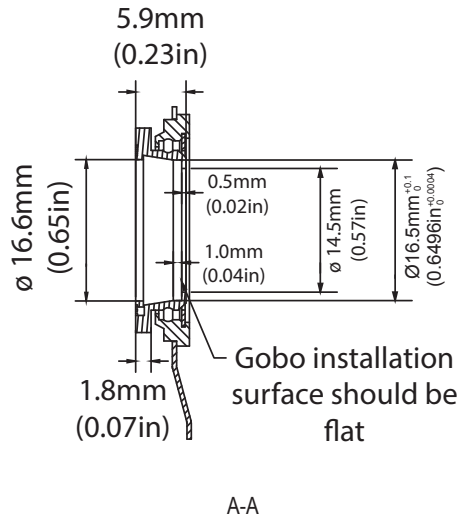
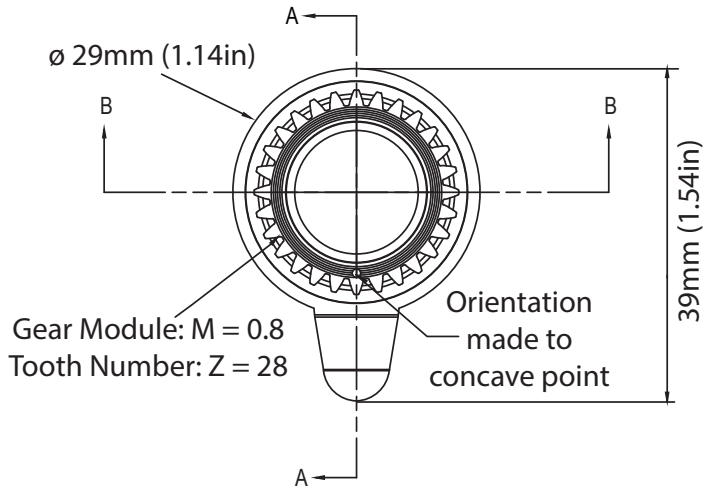

Ensure that gobo ring, gobo, and retainer are securely installed before inserting gobo holder back onto gobo wheel.

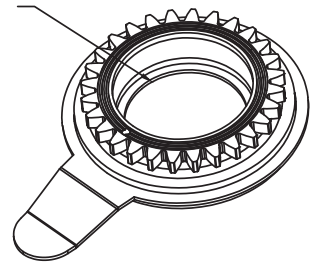

GOBOS

REPLACEMENT PROCEDURE

1. Place the device on a flat, stable surface, and allow the device to cool down for at least 1 hour before beginning this procedure.
2. Remove the screws holding the head covers in place, and detach the clips for the head cover security cables. Remove the head covers.
3. Locate the gobo module, which is the second module from the bottom, as shown in the illustration below. Disconnect any electrical connectors linking the module to the fixture head, and remove the screws holding the module in place. Slide the module out of the head.

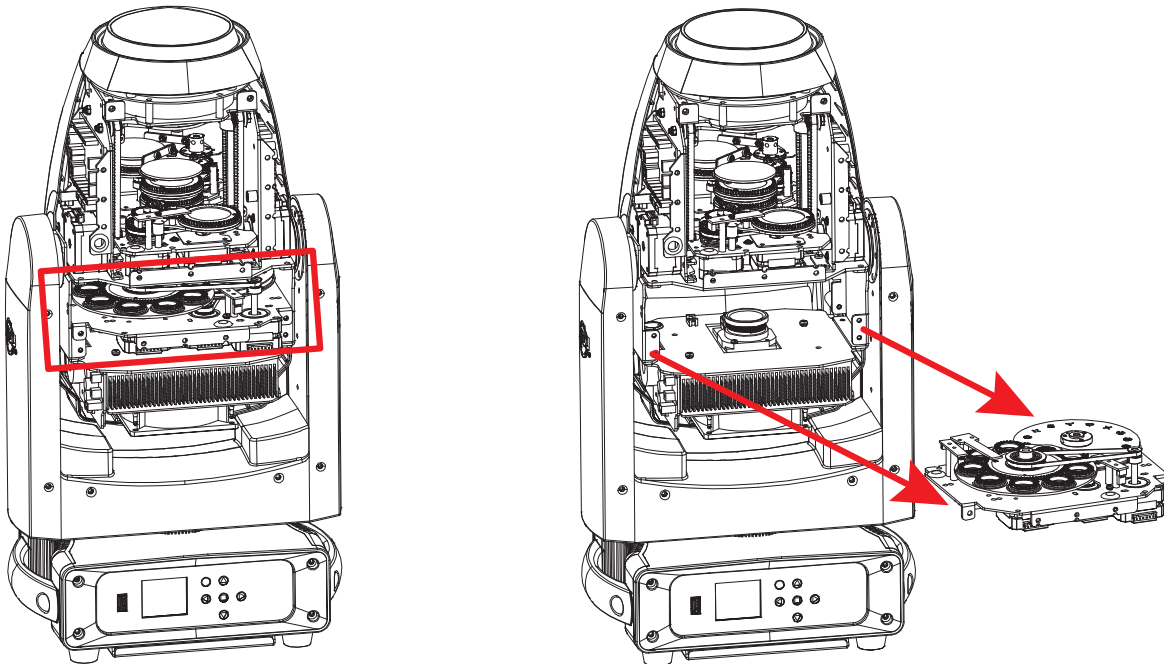

4. Pull the gobo holder away from the gobo wheel, then gently slide it outwards. Use a pair of needle nose pliers to carefully remove the retainer spring from the gobo holder. The gobo can now be removed from the gobo holder, and replaced with a new gobo. Reassemble by reversing these steps.

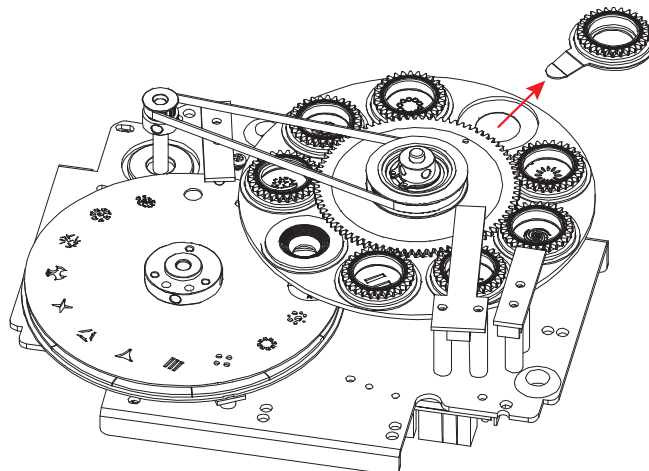

CONTROL PANEL

The Focus Hybrid features a display screen with a 6-button control pad, which can be used to easily adjust any device settings.

- The MODE button cycles through main menu options, or returns to the previous menu without making changes.
- The ENTER button is used to select the highlighted option, or to confirm a selection.
- The UP, DOWN, LEFT, and RIGHT buttons are used to navigate and adjust menu options and settings displayed on the screen.

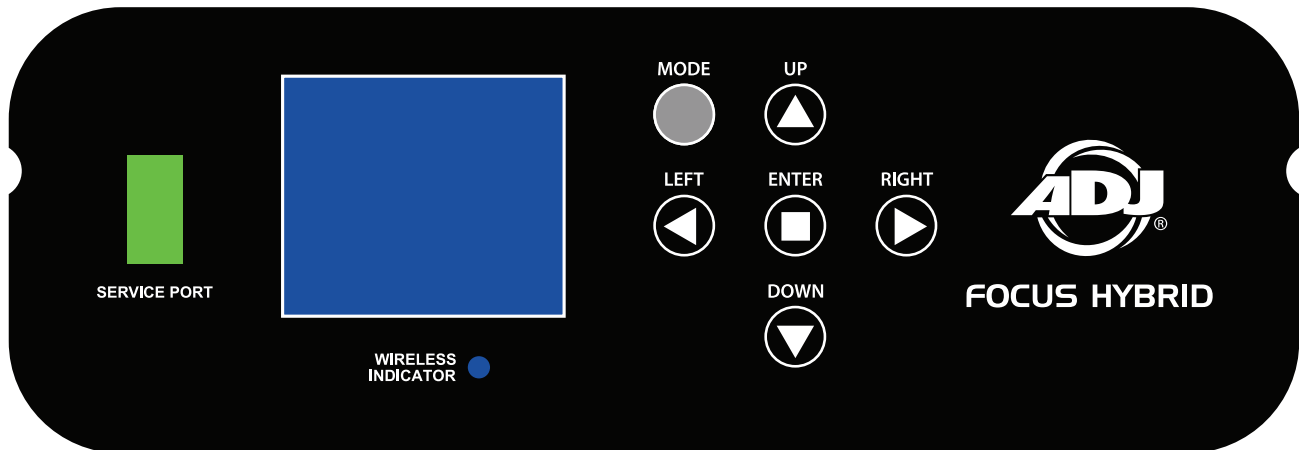

KEY LOCK

This function allows the user to configure whether or not the display screen and control panel keys will lock after a certain period of inactivity. It can be accessed by navigating to *Personality > Display > Key Lock* in the system menu. The setting options are described below:

- **OFF:** The display screen and control panel keys remain active at all times.
- **ON:** The display screen and control panel keys automatically lock after a certain period of inactivity, which can be set under *Personality > Display > Screen Saver Delay*. To unlock, press and hold the MODE button for 10 seconds.
- **ON1:** The display screen and control panel keys automatically lock after a certain period of inactivity, which can be set under *Personality > Display > Screen Saver Delay*. To unlock, press UP, DOWN, UP, DOWN, ENTER in that order.

SOFTWARE UPDATES

The control panel features a Service Port for use in updating this fixture's software. Please contact ADJ service for instructions and software updates.

SYSTEM MENU

DMX SETTINGS	DMX Address	001 - xxx			
	DMX Channel Mode	Basic 19			
		Standard 23			
		Extended 25			
	No DMX Status	Hold Last			
		Blackout			
Manual					
Internal Programs					
PERSONALITY	Prim/Sec Mode	Primary / Secondary			
	Select Signal	DMX or Wifly		DMX has priority; green LED when Wifly is connected, red LED when Wifly is connected	
		Wifly and DMX Out		DMX XLR output sends DMX signal out	
	Wifly Settings	Wifly Enable	On / Off		When Wifly is enabled and connected, a signal strength indicator bar will be shown
		Set Wifly Channel	00 - 14		
	Status Settings	Pan Degree	540 / 630		
		Pan Invert	On / Off		
		Tilt Invert	On / Off		
		P/T Feedback	On / Off		
		P/T Speed	Speed 1		
			Speed 2		
	Speed 3				
	Hibernation	Off, 01min - 99min		Default = 15min	
	Fan Settings	Head Fan	Auto		
			High		
			Low		
		Base Fan	Auto		
			High		
			Low		
	Zoom Speed	Standard			
Fast					

CONTINUED ON NEXT PAGE

SYSTEM MENU

PERSONALITY (continued)	Dim Modes	Standard			
		Stage			
		TV			
		Architectural			
		Theatre			
		Stage 2			
		Dim Speed	0.1s - 10.0s		
	LED Refresh Rate	900-1500 Hz, 2500 Hz, 4000 Hz, 5000 Hz, 6000 Hz, 10 KHz, 15 KHz, 20 KHz, 25 KHz		Default = 1200 Hz	
	Dim Curve	Square			
		Linear			
		Inv Squa			
		S Curve			
	Reset Motors	Reset All Motors	Yes / No		
		Pan/Tilt Reset	Yes / No		
			
		Effect Reset	Yes / No		
	Display	Intensity	1 - 10		
		Display Invert	Yes / No		
		Screen Saver Delay	Off - 10min		
		Key Lock	Off		
			On		
			On1		
	Service	Passcode = 050	Effect Adjust (Calibration)	Pan 000 - 255	
				Tilt 000 - 255	
				Color1 000 - 255	
				...	
Update Software		Off / On			
Factory Restore Passcode = 011		Off / On			
MANUAL CONTROL	Pan	000 - 255			
	Pan Fine	000 - 255			
	Tilt	000 - 255			
	Tilt Fine	000 - 255			
			
INTERNAL PROGRAMS	Program 1	Speed	000 - 255		
		Fade	000 - 255		
		
	Program 7	Speed	000 - 255		
		Fade	000 - 255		

CONTINUED ON NEXT PAGE

SYSTEM MENU

INFORMATION	Fixture Life Time	Power On Time	xxxxxx Hours		Total time fixture has been powered on over its entire life	
		P-On Time-R	xxxxxx Hours		Time fixture has been powered on since last reset	
		P-On Time-Reset	Passcode = 050		Reset P-On Time-R	
	Total LED Time	LED On Time	xxxxxx Hours		Total time LED has been powered on over fixture's entire life	
		LED On Time-R	xxxxxx Hours		Time LED has been powered on since last reset	
		LED Hours Reset	Passcode = 050		Reset LED On Time-R	
	Fixture Temps	LEDs	Current	xxx F / xxx C		Current LED temperature
			Max Resettable	xxx F / xxx C		Max LED temperature since last rest
		Base Temp	Current	xxx F / xxx C		Current base temperature
			Max Resettable	xxx F / xxx C		Max base temperature since last reset
		Reset LED Temp	Yes / No	Passcode = 050		
		Reset Base Temp	Yes / No	Passcode = 050		
	Fan Info (RPM)	LED Fan	xxxx RPM LED			
		Base Fan	xxxx RPM			
	DMX Values	Pan				
		Pan Fine				
		...				
	Error Logs	xxxxx				Lists errors one by one
		Reset Error Log	Yes / No	Passcode = 050		
	Software Version	V: xxx				

DMX SET UP

DMX-512: DMX is short for Digital Multiplex. This is a universal protocol used as a form of communication between intelligent fixtures and controllers. A DMX controller sends DMX data instructions from the controller to the fixture. DMX data is sent as serial data that travels from fixture to fixture via the DATA “IN” and DATA “OUT” XLR terminals located on all DMX fixtures (most controllers only have a DATA “OUT” terminal).

DMX Linking: DMX is a language allowing all makes and models of different manufacturers to be linked together and operate from a single controller, as long as all fixtures and the controller are DMX compliant. To ensure proper DMX data transmission, try to use the shortest cable path possible when linking several DMX fixtures. The order in which fixtures are connected in a DMX line does not influence the DMX addressing. For example, a fixture assigned a DMX address of 1 may be placed anywhere in a DMX line: at the beginning, at the end, or anywhere in the middle. When a fixture is assigned a DMX address of 1, the DMX controller knows to send DATA assigned to address 1 to that unit, no matter where it is located in the DMX chain.

Data Cable (DMX Cable) Requirements (For DMX Operation): This unit can be controlled via DMX-512 protocol. The DMX address is set on the rear panel of the unit. Your unit and your DMX controller require a standard 5-pin XLR connector for data input and data output. We recommend Accu-Cable DMX cables. If you are making your own cables, be sure to use standard 110-120 Ohm shielded cable (This cable may be purchased at almost all pro lighting stores). Your cables should be made with a male XLR connector at one end and a female XLR connector at the other. Also remember that DMX cable must be daisy chained and cannot be split.

Notice: Be sure to follow the diagram below when making your own cables. Do not use the ground lug on the XLR connector. Do not connect the cable’s shield conductor to the ground lug or allow the shield conductor to come into contact with the XLR’s outer casing. Grounding the shield could cause a short circuit and erratic behavior.

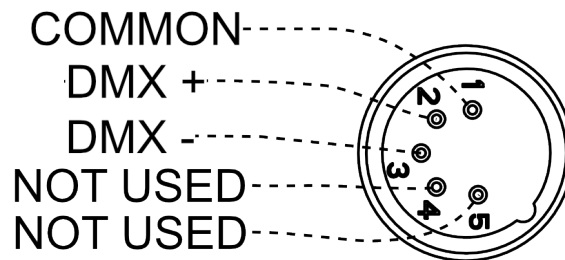

Special Note: Line Termination. When longer runs of cable are used, you may need to use a terminator on the last unit to avoid erratic behavior. A terminator is a 110-120 ohm 1/4 watt resistor which is connected between pins 2 and 3 of a male XLR connector (DATA + and DATA -). This unit is inserted in the female XLR connector of the last unit in your daisy chain to terminate the line. Using a cable terminator (ADJ part number Z-DMX/T) will reduce the risk of erratic behavior.

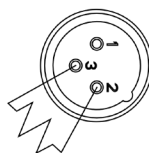
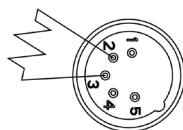

A DMX512 terminator reduces signal errors, avoiding most signal reflection interference. Connect PIN 2 (DMX-) and PIN 3 (DMX+) of the last fixture in series with a 120 Ohm, 1/4 W Resistor to terminate the DMX512.

DMX SET UP

DMX ADDRESSING.

All fixtures should be given a DMX starting address when using a DMX controller, so the correct fixture responds to the correct control signal. This digital starting address is the channel number from which the fixture starts to “listen” to the digital control signal sent out from the DMX controller. The assignment of this starting DMX address is achieved by setting the correct DMX address on the digital control display on the fixture.

You can set the same starting address for all fixtures or a group of fixtures, or set different addresses for each individual fixture. Setting all fixtures to the same DMX address will cause all fixtures to react in the same way. In other words, changing the settings of one channel will affect all the fixtures simultaneously.

If you set each fixture to a different DMX address, each unit will start to “listen” to the channel number you have set, based on the quantity of DMX channels of each fixture. That means changing the settings of one channel will only affect the selected fixture.

For example, when this unit is operating in 19 channel mode, you should set the starting DMX address of the first unit to 1, the second unit to 20 (1 + 19), the third unit to 39 (1 + 19 + 19), and so on. See the chart below for more details.

CHANNEL MODE	UNIT 1 ADDRESS	UNIT 2 ADDRESS	UNIT 3 ADDRESS	UNIT 4 ADDRESS
19 Ch	1	20	39	58
23 Ch	1	24	47	70
25 Ch	1	26	51	76

DMX TRAITS

CHANNEL			DMX VALUES	FUNCTION
19 CH	23 CH	25 CH		
1	1	1	000 - 255	Pan Movement (540/630)
	2	2	000 - 255	Pan Fine
2	3	3	000 - 255	Tilt Movement (270)
	4	4	000 - 255	Tilt Fine
3	5	5		Color Wheel
			000 - 008	Open / White
			009 - 013	Red
			014 - 018	Blue
			019 - 023	Green
			024 - 028	Yellow
			029 - 033	Orange
			034 - 038	Purple
			039 - 043	Magenta
			044 - 048	Dark Blue
			049 - 053	Light Blue
			054 - 058	Light Green
			059 - 063	3200K CTO
			064 - 127	Color Mixing
			128 - 189	Clockwise Color Wheel Rotation, fast to slow
190 - 193	No Rotation			
194 - 255	Counter-Clockwise Color Wheel Rotation, slow to fast			
4	6	6		Rotating Gobo Wheel
			000 - 005	Open
			006 - 014	Gobo 1
			015 - 023	Gobo 2
			024 - 032	Gobo 3
			033 - 041	Gobo 4
			042 - 050	Gobo 5
			051 - 059	Gobo 6
			060 - 068	Gobo 7
			069 - 077	Gobo 8
			078 - 091	Gobo 1 shake, slow to fast
			092 - 105	Gobo 2 shake, slow to fast
			106 - 119	Gobo 3 shake, slow to fast
			120 - 133	Gobo 4 shake, slow to fast
			134 - 147	Gobo 5 shake, slow to fast
			148 - 161	Gobo 6 shake, slow to fast
			162 - 175	Gobo 7 shake, slow to fast
176 - 189	Gobo 8 shake, slow to fast			

CONTINUED ON NEXT PAGE

DMX TRAITS

CHANNEL			DMX VALUES	FUNCTION
19 CH	23 CH	25 CH		
4	6	6		<i>Rotating Gobo Wheel (continued)</i>
			190 - 221	Clockwise Gobo Wheel Rotation, fast to slow
			222 - 223	No Rotation
			224 - 255	Counter-Clockwise Gobo Wheel Rotation, slow to fast
5	7	7		<i>Gobo Rotation</i>
			000 - 127	Indexing
			128 - 189	Clockwise Gobo Rotation, fast to slow
			190 - 192	No Rotation
6	8	8		<i>Static Gobos</i>
			000 - 009	Open (8mm)
			010 - 013	Gobo 1
			014 - 017	Gobo 2
			018 - 021	Gobo 3
			022 - 025	Gobo 4
			026 - 029	Gobo 5
			030 - 033	Gobo 6
			034 - 037	Gobo 7
			038 - 041	Gobo 8
			042 - 045	Gobo 9
			046 - 049	Gobo 10
			050 - 053	Gobo 11
			054 - 057	Gobo 12
			058 - 061	Gobo 13
			062 - 065	Gobo 14
			066 - 069	Gobo 15 (open 15mm)
			070 - 077	Gobo 1 shake, slow to fast
			078 - 085	Gobo 2 shake, slow to fast
			086 - 093	Gobo 3 shake, slow to fast
			094 - 101	Gobo 4 shake, slow to fast
			102 - 109	Gobo 5 shake, slow to fast
			110 - 117	Gobo 6 shake, slow to fast
			118 - 125	Gobo 7 shake, slow to fast
			126 - 133	Gobo 8 shake, slow to fast
			134 - 141	Gobo 9 shake, slow to fast
142 - 149	Gobo 10 shake, slow to fast			
150 - 157	Gobo 11 shake, slow to fast			
158 - 165	Gobo 12 shake, slow to fast			
166 - 173	Gobo 13 shake, slow to fast			

CONTINUED ON NEXT PAGE

DMX TRAITS

CHANNEL			DMX VALUES	FUNCTION
19 CH	23 CH	25 CH		
6	8	8		Static Gobos (continued)
			174 - 181	Gobo 14 shake, slow to fast
			182 - 189	Gobo 15 shake, slow to fast
			190 - 221	Clockwise Gobo Wheel Rotation, fast to slow
			222 - 223	No Rotation
			224 - 255	Counter-Clockwise Gobo Wheel Rotation, slow to fast
7	9	9		Shutter
			000 - 031	Shutter closed
			032 - 063	Shutter open
			064 - 095	Strobe, slow to fast
			096 - 127	Shutter open
			128 - 159	Pulse Effect, slow to fast
			160 - 191	Shutter open
			192 - 223	Random Strobe, slow to fast
			224 - 255	Shutter open
8	10	10	000 - 255	Dimmer Intensity , 0% to 100%
	11	11	000 - 255	Dimmer Intensity Fine
9	12	12		Prism 1
			000 - 031	Open
			032 - 255	8 Facet Circular Prism
10	13	13		Prism 1 Index / Rotation
			000 - 005	Prism Rotation Off
			006 - 128	Prism Indexing, 0...540°
			129 - 191	Clockwise Prism Rotation, fast to slow
			192	No Rotation
			193 - 255	Counter-Clockwise Prism Rotation, slow to fast
11	14	14		Prism 1 / Gobo Macros
			000 - 014	No Prism - Open
			015 - 029	Macro 1
			030 - 044	Macro 2
			045 - 059	Macro 3
			060 - 074	Macro 4
			075 - 089	Macro 5
			090 - 104	Macro 6
			105 - 119	Macro 7
			120 - 134	Macro 8
			135 - 149	Macro 9
			150 - 164	Macro 10
			165 - 179	Macro 11

CONTINUED ON NEXT PAGE

DMX TRAITS

CHANNEL			DMX VALUES	FUNCTION
19 CH	23 CH	25 CH		
11	14	14		<i>Prism 1 / Gobo Macros (continued)</i>
			180 - 194	Macro 12
			195 - 209	Macro 13
			210 - 224	Macro 14
			225 - 239	Macro 15
		240 - 255	Macro 16	
12	15	15		<i>Prism 2</i>
			000 - 031	Open
			032 - 255	6 Facet Linear Prism
13	16	16		<i>Prism 2 Index / Rotation</i>
			000 - 005	Prism Rotation Off
			006 - 128	Prism Indexing, 0...540°
			129 - 191	Clockwise Prism Rotation, fast to slow
			192	No Rotation
		193 - 255	Counter-Clockwise Prism Rotation, slow to fast	
14	17	17		<i>Prism 2 / Gobo Macros</i>
			000 - 014	No Prism - Open
			015 - 029	Macro 1
			030 - 044	Macro 2
			045 - 059	Macro 3
			060 - 074	Macro 4
			075 - 089	Macro 5
			090 - 104	Macro 6
			105 - 119	Macro 7
			120 - 134	Macro 8
			135 - 149	Macro 9
			150 - 164	Macro 10
			165 - 179	Macro 11
			180 - 194	Macro 12
			195 - 209	Macro 13
210 - 224	Macro 14			
225 - 239	Macro 15			
240 - 255	Macro 16			
15	18	18	000 - 255	<i>Focus</i> , 0% to 100%
16	19	19	000 - 255	<i>Zoom</i> , narrow to wide
		20	000 - 255	<i>Zoom Fine</i>
17	20	21	000 - 255	<i>Frost</i> , open to full frost
CONTINUED ON NEXT PAGE				

DMX TRAITS

CHANNEL			DMX VALUES	FUNCTION
19 CH	23 CH	25 CH		
	21	22		<i>Dimmer Modes</i>
			000 - 020	Default to Unit Setting
			021 - 040	Standard
			041 - 060	Stage
			061 - 080	TV
			081 - 100	Architectural
			101 - 120	Theater
			121 - 140	Stage 2
			141 - 160	Dim Speed, fast to slow (0.1s - 10.0s)
		161 - 255	Default to Unit Setting	
		23		<i>Dim Curves</i>
			000 - 020	Square
			021 - 040	Linear
			041 - 060	Inv. Squa
			061 - 080	S. Curve
		081 - 255	No function	
18	22	24		<i>Pan/Tilt Speed</i>
			000 - 225	Pan/Tilt Speed, fast to slow
			226 - 235	Blackout by movement
			236 - 245	Blackout by all wheel changing
		246 - 255	No function	
19	23	25		<i>Special Functions</i>
			000 - 029	No function
			030 - 039	Fan Control - Mute (hold 3s)
			040 - 049	Fan Control - Low (hold 3s)
			050 - 059	Fan Control - High (hold 3s)
			060 - 069	Fan Control - Auto (default) (hold 3s)
			070 - 074	All Motor Reset (hold 3s)
			075 - 079	Pan/Tilt Reset (hold 3s)
			080 - 084	Color Reset (hold 3s)
			085 - 089	Gobo Reset (hold 3s)
			090 - 094	Focus and Zoom Reset (hold 3s)
			095 - 099	Shutter Reset (hold 3s)
			100 - 104	Prism Reset
			105 - 109	Other Motors Reset (hold 3s)
			110 - 148	No function
149 - 150	Wifly On (default) (hold 3s)			
151 - 152	Wifly Off (hold 5s)			
153 - 154	Hibernation Enable (hold 3s)			

CONTINUED ON NEXT PAGE

DMX TRAITS

CHANNEL			DMX VALUES	FUNCTION
19 CH	23 CH	25 CH		
19	23	25		<i>Special Functions (continued)</i>
			155 - 156	Hibernation Off (hold 5s)
			157 - 158	Display Backlight On (hold 3s)
			159 - 160	Display Backlight Off (hold 5s)
			161 - 162	Pan/Tilt Speed 1 (default) (hold 5s)
			163 - 164	Pan/Tilt Speed 2
			165 - 166	Invert Pan On (hold 3s)
			167 - 168	Invert Pan Off (hold 5s)
			169 - 170	Invert Tilt On (hold 3s)
			171 - 172	Invert Tilt Off (hold 5s)
				<i>LED Refresh Rate (hold 1s)</i>
			173	900 Hz
			174	910 Hz
			175	920 Hz
			176	930 Hz
			177	940 Hz
			178	950 Hz
			179	960 Hz
			180	970 Hz
			181	980 Hz
			182	990 Hz
			183	1000 Hz
			184	1010 Hz
			185	1020 Hz
			186	1030 Hz
			187	1040 Hz
			188	1050 Hz
			189	1060 Hz
			190	1070 Hz
			191	1080 Hz
192	1090 Hz			
193	1100 Hz			
194	1110 Hz			
195	1120 Hz			
196	1130 Hz			
197	1140 Hz			
198	1150 Hz			
199	1160 Hz			
200	1170 Hz			

CONTINUED ON NEXT PAGE

DMX TRAITS

CHANNEL			DMX VALUES	FUNCTION
19 CH	23 CH	25 CH		
19	23	25		<i>LED Refresh Rate (hold 1s) (continued)</i>
			201	1180 Hz
			202	1190 Hz
			203	1210 Hz
			204	1220 Hz
			205	1230 Hz
			206	1240 Hz
			207	1250 Hz
			208	1260 Hz
			209	1270 Hz
			210	1280 Hz
			211	1290 Hz
			212	1300 Hz
			213	1310 Hz
			214	1320 Hz
			215	1330 Hz
			216	1340 Hz
			217	1350 Hz
			218	1360 Hz
			219	1370 Hz
			220	1380 Hz
			221	1390 Hz
			222	1400 Hz
			223	1410 Hz
			224	1420 Hz
			225	1430 Hz
			226	1440 Hz
			227	1450 Hz
			228	1460 Hz
			229	1470 Hz
			230	1480 Hz
			231	1490 Hz
			232	1500 Hz
			233	2500 Hz
			234	4000 Hz
			235	5000 Hz
			236	6000 Hz
			237	10,000 Hz
238	15,000 Hz			
CONTINUED ON NEXT PAGE				

DMX TRAITS

CHANNEL			DMX VALUES	FUNCTION
19 CH	23 CH	25 CH		
19	23	25		<i>LED Refresh Rate (hold 1s) (continued)</i>
			239	20,000 Hz
			240	25,000 Hz
				<i>Internal Programs (hold 3s)</i>
			241	Program 1 (scenes 1-8)
			242	Program 2 (scenes 9-16)
			243	Program 3 (scenes 17-24)
			244	Program 4 (scenes 25-32)
			245	Program 5 (scenes 33-40)
			246	Program 6 (scenes 41-48)
			247	Program 7 (scenes 49-56)
			248 - 255	No function

DIM SPEEDS

DMX VALUES	DELAY TIME
141	0.1 sec
142	0.2 sec
143	0.3 sec
144	0.4 sec
145	0.5 sec
146	0.6 sec
147	0.7 sec
148	0.8 sec
149	0.9 sec
150	1.0 sec
151	1.5 sec
152	2.0 sec
153	3.0 sec
154	4.0 sec
155	5.0 sec
156	6.0 sec
157	7.0 sec
158	8.0 sec
159	9.0 sec
160	10.0 sec

DIM MODES

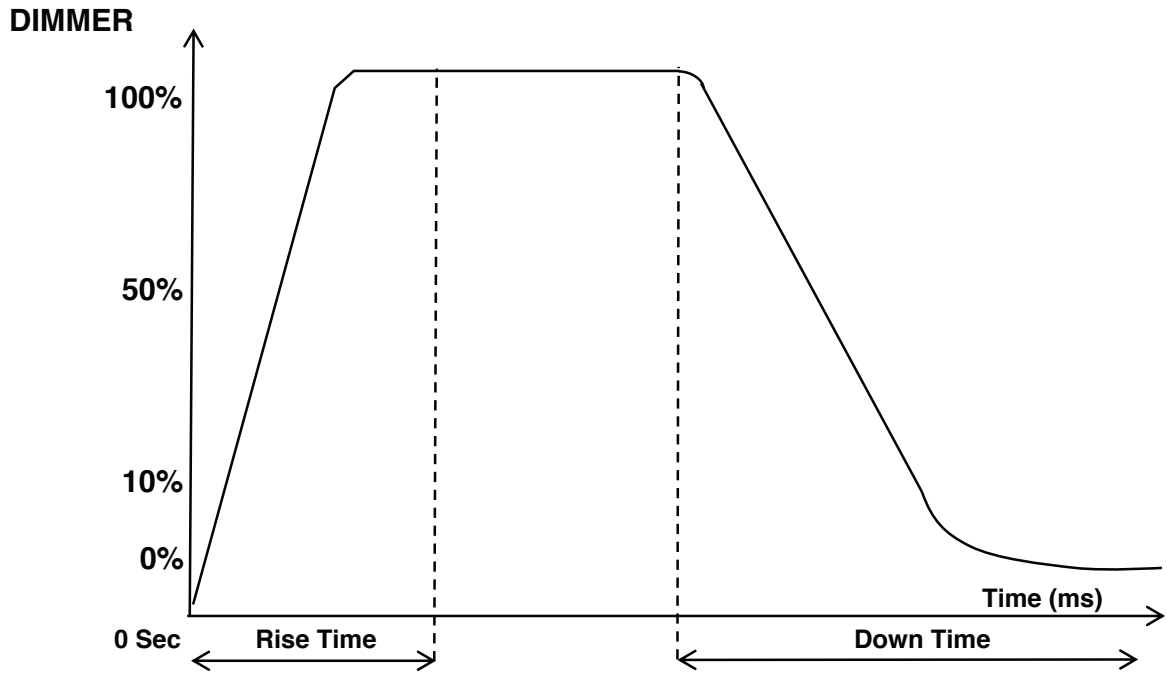

Dimming Curve Ramp Effect	0 sec Fade Time		1 sec Fade Time	
	Rise Time (ms)	Down Time (ms)	Rise Time (ms)	Down Time (ms)
Standard (default)	0	0	0	0
Stage	780	1100	1540	1660
TV	1180	1520	1860	1940
Architectural	1380	1730	2040	2120
Theatre	1580	1940	2230	2280
Stage 2	0	1100	0	1660

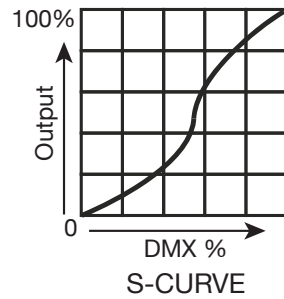
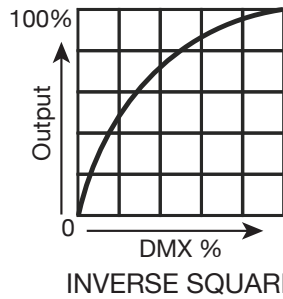
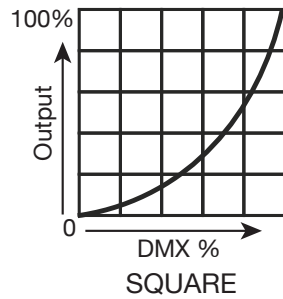
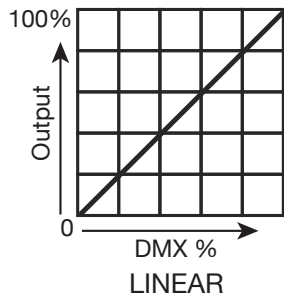

PRIMARY-SECONDARY SET UP

This function allows you to link units together to run in a Primary-Secondary set-up, in which one unit will act as the controlling unit and the others will react to the controlling unit's built-in programs. Any unit can be configured to act as a Primary or as a Secondary, but only one unit in a given system can be programmed to act as the Primary.

Primary-Secondary Connections and Settings:

1. Daisy chain your units via the XLR connectors on the rear panels of each unit. Use standard XLR data cables to link your units together. Remember that the male XLR connector is the input and the female XLR connector is the output. The first unit in the chain (primary) will use the female XLR connector only, while the last unit in the chain will use the male XLR connector only.
2. Use the display screen and control panel to navigate to Personality > Prim/Sec Mode. Select this sub-menu using the ENTER button, and use the arrows to toggle between "Primary" and "Secondary". Press ENTER to confirm your selection.
3. Repeat Step 2 for each unit in the system. Make sure that only one unit is designated as the Primary, while all other units are designated as Secondaries.
4. The secondary units will now follow the behavior of the primary unit.

MULTI UNIT POWER LINKING

This feature allows you to connect the fixtures to one another using the power cable input and output sockets.

The maximum number of units that can be linked in this manner is as follows:

- 2 units when running on 120V power.
- 6 units when running on 240V power.

DO NOT EXCEED THIS MAXIMUM NUMBER WHEN POWER LINKING UNITS!

All linked units must be of the same make and model type. Do not mix and match units!

MAINTENANCE GUIDELINES



DISCONNECT POWER BEFORE PERFORMING ANY MAINTENANCE!

CLEANING

Frequent cleaning is recommended to ensure proper function, optimized light output, and an extended life. The frequency of cleaning depends on the environment in which the fixture operates: damp, smoky, or particularly dirty environments can cause greater accumulation of dirt on the fixture's optics. Clean the external lens surface regularly with a soft cloth to avoid dirt/debris accumulation.

NEVER use alcohol, solvents, or ammonia-based cleaners.

MAINTENANCE

Regular inspections are recommended to ensure proper function and extended life. There are no user serviceable parts inside this fixture. Please refer all other service issues to an authorized ADJ service technician. Should you need any spare parts, please order genuine parts from your local ADJ dealer.

Please refer to the following points during routine inspections:

- A. A detailed electrical check by an approved electrical engineer every three months, to make sure the circuit contacts are in good condition and prevent overheating.
- B. Be sure all screws and fasteners are securely tightened at all times. Loose screws may fall out during normal operation, resulting in damage or injury as larger parts could fall.
- C. Check for any deformations on the housing, color lenses, rigging hardware, and rigging points (ceiling, suspension, trussing). Deformations in the housing could allow for dust to enter into the fixture. Damaged rigging points or unsecured rigging could cause the fixture to fall and seriously injure a person(s).
- D. Electric power supply cables must not show any damage, material fatigue, or sediments.

NEVER remove the ground prong from the power cable.

SOFTWARE UPDATES

For software updates, please contact ADJ service to obtain a software uploader and detailed instructions. Refer to the ***Introduction*** section of this manual for contact information.

ERROR CODES

When power is applied, the unit will automatically enter a “**Reset/Test**” mode. This mode brings all the internal motors to a home position. If there is an internal problem with one or more of the motors, an error code will flash in the display, as described in the chart below. For example, when the display shows “Pan” it means there is some type of error with the Pan motor. If there are multiple errors during the start-up process, they will all flash in the display. For example: if the fixtures have errors on Pan, Tilt, and Color Wheel all at the same time, you will see the error message “Pan”, “Tilt”, and “Color Wheel” flash in sequence. The error sequence will repeat 5 times.

If an error does occur during the initial start-up procedure, the fixture will self-generate a second reset signal and try to realign all the motors and correct the errors. If the error persists after a second attempt, a third attempt will be made. If after a third attempt all the errors have not been corrected, the fixture will make the following determinations:

- **3 or More Errors:** The fixture cannot function properly with three or more errors. Therefore the fixture will place itself in a stand-by mode until subsequent repairs can be made.
- **Less Than 3 Errors:** The fixture has less than 3 errors. Therefore, most other functions will work properly. The fixture will attempt to operate normally until the errors can be correct by a technician. The errors in question will remain flashing in the display as a reminder of internal errors.

Error Code	Description
Pan	Pan Error
Tilt	Tilt Error
Color Wheel	Color Wheel Error
Rot Gobo	Rotating Gobo Error
Fixed Gobo	Fixed Gobo Error
Zoom	Zoom Error
Focus	Focus Error
Prism 1	Prism 1 Error
Prism 1 Rot	Prism 1 Rotation Error
Prism 2	Prism 2 Error
Prism 2 Rot	Prism 2 Rotation Error
LED Fan	LED Fan Error
Gobo Fan	Gobo Fan Error
Base Fan	Base Fan Error
Head Temp	Head Temperature Error
Base Temp	Base Temperature Error

DIMENSIONS

DRAWINGS NOT TO SCALE

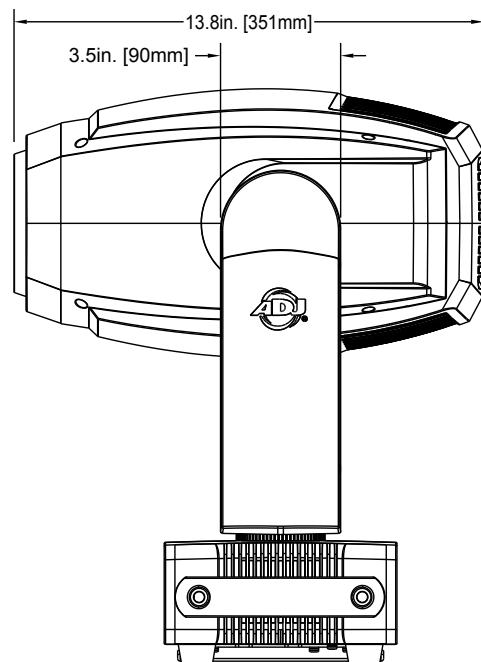
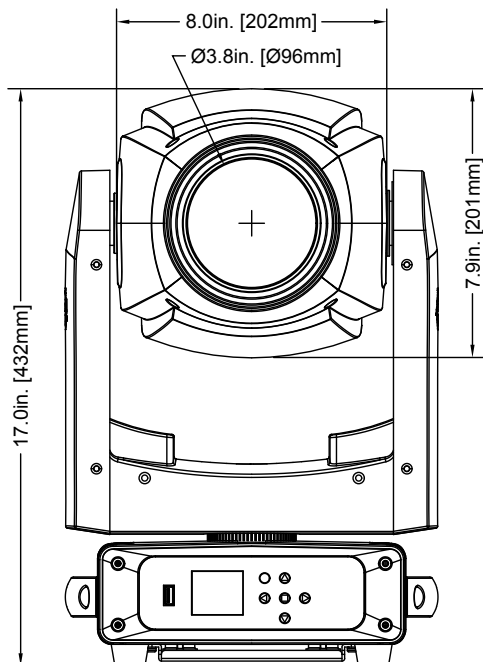
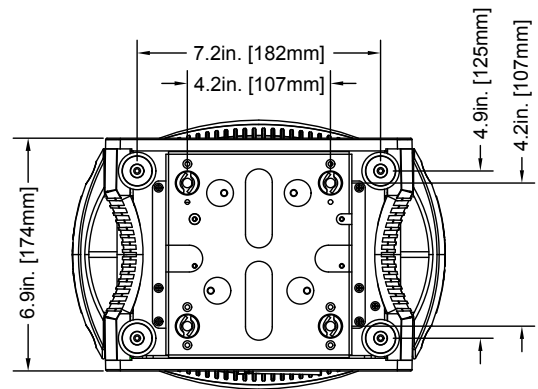
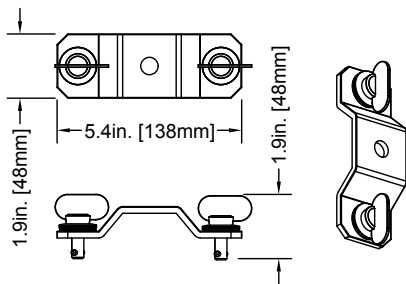
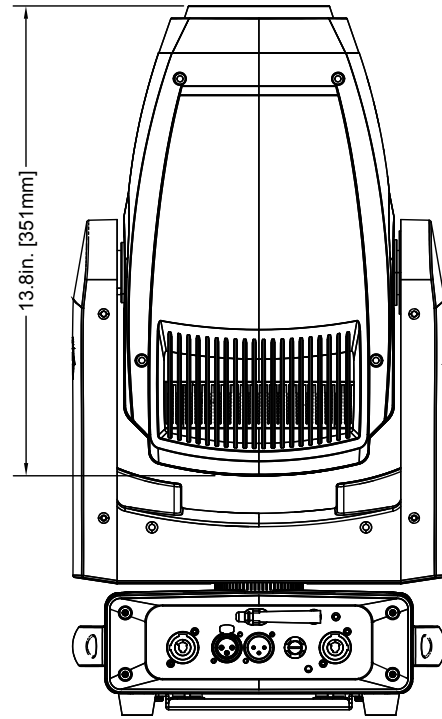
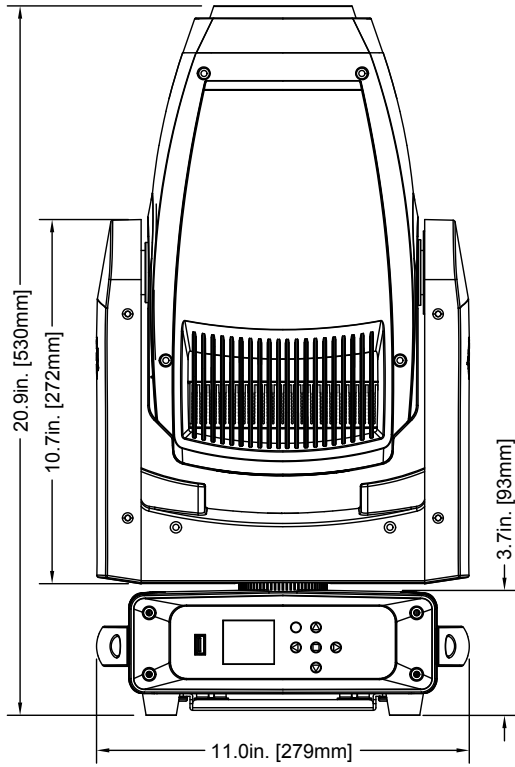

SPECIFICATIONS

SOURCE

200W LED Engine
50,000 Hour Average LED Life

PHOTOMETRIC DATA

4,100 Total Lumens
7,500K, >70CRI
57,433 LUX 5,336 FC @16.4' (5m) (3.1° Beam)
1,293 LUX 120 FC @16.4' (5m) (23.8° Beam)

EFFECTS

8-Facet Circular & 6-Facet Linear Rotating Prisms
Prism Layering
Replaceable Frost Filter (Heavy Frost Default)
Motorized Zoom (2° to 24°)
Motorized Focus
Electronic Dimming & Strobe (1-20Hz)

COLOR

Color Wheel with 11 dichroic colors, includes 3200 CTO Filter

GOBOS

(2) Gobo Wheels
#1 - (7) Interchangeable Rotating-Indexing Gobos
#2 - (15) Static-Stamped Gobos

CONTROL / CONNECTIONS

(3) DMX Channel Modes (19 / 23 / 25)
WiFLY EXR Wireless DMX Built-in (2500 ft. 700M line of sight)
RDM (Remote Device Management)
6 Button Touch Control Panel
Full Color 180° Reversible LCD Menu Display
8 / 16 Bit Resolution Adjustable Movement
5 pin XLR DMX In/Out
Locking In/Thru power connections
Antenna on rear for WiFLY EXR Wireless DMX connection
With Wired Digital Communication Network

PAN / TILT

Pan: 540-degrees
Tilt: 270-degrees

SIZE / WEIGHT

Length: 13.8" (351mm)
Width: 11.0" (279mm)
Vertical Height: 20.9" (530mm)
Weight: 31 lbs. (14kg)

ELECTRICAL / THERMAL

AC 100-240V - 50/60Hz
Max Power Consumption: 335W
Max ambient temperature: -13°F to 113°F (-25°C to 45°C)
Max housing temperature: 136°F (58°C)

TECHNICAL DATA

DB Rating @ 3ft.: 43.2dB
BTU: 0.32
BTU/H: 1,142.35

APPROVALS / RATINGS

CE I ETL (Pending)
IP20

INCLUDED ACCESSORIES

(1) Power cable
(2) Omega brackets
(1) Medium frost filter

Specifications and documentation subject to change without notice.

