



# ENCORE LBI5IP

## User Manual

©2023 ADJ Products, LLC all rights reserved. Information, specifications, diagrams, images, and instructions herein are subject to change without notice. ADJ Products, LLC logo and identifying product names and numbers herein are trademarks of ADJ Products, LLC. Copyright protection claimed includes all forms and matters of copyrightable materials and information now allowed by statutory or judicial law or hereinafter granted. Product names used in this document may be trademarks or registered trademarks of their respective companies and are hereby acknowledged. All non-ADJ Products, LLC brands and product names are trademarks or registered trademarks of their respective companies.

**ADJ Products, LLC** and all affiliated companies hereby disclaim any and all liabilities for property, equipment, building, and electrical damages, injuries to any persons, and direct or indirect economic loss associated with the use or reliance of any information contained within this document, and/or as a result of the improper, unsafe, insufficient and negligent assembly, installation, rigging, and operation of this product.

**ADJ PRODUCTS LLC World Headquarters**

6122 S. Eastern Ave. | Los Angeles, CA 90040 USA

Tel: 800-322-6337 | Fax: 323-582-2941 | [www.adj.com](http://www.adj.com) | [lsupport@adj.com](mailto:lsupport@adj.com)

**ADJ Supply Europe B.V.**

Junostraat 2 | 6468 EW Kerkrade | Netherlands

Tel: +31 45 546 85 00 | Fax: +31 45 546 85 99 | [www.americandj.eu](http://www.americandj.eu) | [service@americandj.eu](mailto:service@americandj.eu)

Europe Energy Saving Notice

Energy Saving Matters (EuP 2009/125/EC)

Saving electric energy is a key to help protecting the environment. Please turn off all electrical products when they are not in use. To avoid power consumption in idle mode, disconnect all electrical equipment from power when not in use. Thank you!

**DOCUMENT VERSION**



Due to additional product features and/or enhancements, an updated version of this document may be available online.

Please check [www.adj.com](http://www.adj.com) for the latest revision/update of this manual before beginning installation and/or programming.

Date	Document Version	Software Version	DMX Channels	Notes
05/31/2022	1.0	1.03	4 / 7 / 8 / 13 / 16 / 60 / 63 / 69 / 72 / 120 ch.	Initial Release.
08/04/2022	1.5	N/C	N/C	Updated Dimension Drawings
01/18/2023	2.0	1.04	N/C	Updated RDM System Menu and DMX Traits; added IP65 Rated.

# CONTENTS

Introduction	4
IP65 Rated	5
Limited Warranty (USA Only)	6
Warranty Registration   Features	7
Safety Guidelines	8
Overview	9
Installation	10
Manual Tilt Adjustment	13
Accessory Installation	14
Remote Device Management (RDM)	15
Wifly Guidelines	16
Control Panel	17
System Menu	18
DMX Setup	22
DMX Traits	24
Pixel Zones	31
Color Macro Chart	32
Dimmer Modes	33
Daisy Chain Power Linking   Cleaning and Maintenance	34
Specifications	35
Dimensions	36

# INFORMATION

## INTRODUCTION

The ADJ Encore LB15IP is a DMX intelligent, IP65-rated LED bar. To optimize the performance of this product, please read these operating instructions carefully to familiarize yourself with the basic operations of this unit. These instructions contain important safety information regarding the use and maintenance of this unit. Please keep this manual with the unit for future reference.

## UNPACKING

Every device has been thoroughly tested and has been shipped in perfect operating condition. Carefully check the shipping carton for damage that may have occurred during shipping. If the carton is damaged, carefully inspect the device for damage, and be sure all accessories necessary to install and operate the device have arrived intact. In the event damage has been found or parts are missing, please contact our customer support team for further instructions. Please do not return this device to your dealer without first contacting customer support. Please do not discard the shipping carton in the trash. Please recycle whenever possible.

## FEATURES

The ADJ Encore LB15IP is a versatile LED bar with fifteen (15) 20W Quad LEDs (4-IN-1: Red, Green, Blue & Lime), and a 12.4-degree beam angle. It is IP65 outdoor rated to protect against, rain, snow and dust for temporary outdoor events. It offers flicker free operation for TV and film and linear color temperature control from 2700K - 7000K.

## INCLUDED ITEMS

- Double Faced Frost Filter (x1)
- Glare Shield (x1)
- Power Cable (x1)

**Parts:** To purchase parts online visit:

<http://parts.adj.com> (US)

<http://www.adjparts.eu> (EU)

**ADJ SERVICE USA** - Monday - Friday 8:00am to 4:30pm PST

Voice: 800-322-6337 | Fax: 323-582-2941 | [support@adj.com](mailto:support@adj.com)

**ADJ SERVICE EUROPE** - Monday - Friday 08:30 to 17:00 CET

Voice: +31 45 546 85 60 | Fax: +31 45 546 85 96 | [support@adj.eu](mailto:support@adj.eu)

## ADJ PRODUCTS LLC USA

6122 S. Eastern Ave. Los Angeles, CA. 90040

323-582-2650 | Fax 323-532-2941 | [www.adj.com](http://www.adj.com) | [info@adj.com](mailto:info@adj.com)

## ADJ SUPPLY Europe B.V

Junostraat 2 6468 EW Kerkrade, The Netherlands

+31 (0)45 546 85 00 | Fax +31 45 546 85 99

[www.americandj.eu](http://www.americandj.eu) | [info@americandj.eu](mailto:info@americandj.eu)

## ADJ PRODUCTS GROUP Mexico

AV Santa Ana 30 Parque Industrial Lerma, Lerma, Mexico 52000

+52 (728) 282-7070

**Warning! This unit is intended for indoor use only! Do not expose to rain or moisture!**

**CAUTION! There are no user serviceable parts inside this unit. Do not attempt any repairs yourself, as doing so will void your manufacturer's warranty. In the unlikely event your unit may require service, please contact ADJ Products, LLC.**

Do not discard the shipping carton in the trash. Please recycle when ever possible.

# IP65 RATED

The International Protection (IP) rating system is commonly expressed as “IP” (Ingress Protection) followed by two numbers (i.e. IP65), where the numbers define the degree of protection. The first digit (Foreign Bodies Protection) indicates the extent of protection against particles entering the fixture, and the second digit (Water Protection) indicates the extent of protection against water entering the fixture. **An IP65 rated lighting fixture is designed and tested to protect against the ingress of dust (6), and low-pressure water jets from any direction (5).**

**NOTE: THIS FIXTURE IS INTENDED FOR TEMPORARY OUTDOOR USE ONLY!**

**Maritime/Coastal Environment Installations:** A coastal environment is seaside adjacent, and caustic to electronics through exposure to atomized salt-water and humidity, whereas maritime is anywhere within 5-miles of a coastal environment.



**NOT suitable for maritime/coastal environment installations. Installing this fixture in a maritime/coastal environment may cause corrosion and/or excessive wear to the interior and/or exterior components of the fixture. Damages and/or performance issues resulting from installation in a maritime/coastal environment will void the manufactures warranty, and will NOT be subject to any warranty claims and/or repairs.**

Maritime installations require additional preparation, and additional service intervals may be needed given the maritime use. In general, IP ratings presuppose freshwater conditions VS maritime conditions, which are typically more “caustic” to IP fixtures (both internally and externally). A duty-cycle may also be needed when units are not in use. During times of high humidity and colder temperatures, condensation may occur internally so the fixture may require a duty-cycle to bring it up to running temperature, allowing any accumulation of moisture to be expelled via the vent valve. Recommendations can change based on installation environmental circumstances. A waterproof dome or similar device is recommended for use in permanent outdoor installations. When using a dome, refer to manufacturer recommendations for duty-cycle.

**NOTE: NOT ALL FEATURES LISTED ARE AVAILABLE ON ALL FIXTURES; THE FOLLOWING INSTRUCTIONS MAY NOT APPLY. CONTACT SUPPORT FOR ADDITIONAL DETAILS.**

**Exterior Maintenance:** Inspect the exterior every 30-days. The unit must be powered off/disconnected. Inspect optics to determine if the lens is obstructed, then clean optics and chassis accordingly. Based on initial finding, schedule maintenance accordingly, keeping in mind that exterior maintenance will be required. Even if the luminaires are NOT in use, maintenance will still be needed given its location (exterior use). The use of a durable type of wax on the chassis is recommended since it will help prevent contaminant build up. Inspect both power and data lines for any signs of contaminants or corrosion. Periodically reapplying di-electric grease, especially in coastal environments. If any signs of corrosion/contaminants are present, clean thoroughly, and/or replace connectors, then reapply di-electric grease. Typically, this should be done annually, or any time an opportunity presents itself. As a preventive measure, annual replacement of both vent valves is recommended. The vent valve membrane can become contaminated and/or clogged causing improper venting of humidity within the luminaire. Inspect all mounting hardware as a precaution.

**Interior Maintenance:** Inspect the interior every 30-days, and perform any of the following items that apply to this device. The unit must be powered off/disconnected.

- Inspect zoom/focus mechanism, clean optics, lubricate linear bearings (Krytox oil) as needed, inspect belts for wear
- Inspect all rotating effect wheels, manually rotate them, note any resistance
- Inspect all remaining rotating belts for any wear
- Inspect all fans, clean as needed, check rotation, check connections
- Inspect CMY module, manually move flags and check for signs of resistance, and if needed, clean guide rods first, then reapply a thin layer of grease (moly lube)
- Clean interior with low-volume compressed air, then clean optics prior to reassembly of head covers

Although the base has limited moving parts, the pan belt should also be inspected for wear. Remember to always perform an IP test anytime a cover is removed.

There is no specific time frame regarding the routine replacement of parts such as belts/stepper motors, PCBs, or LEDs. These items should only be replaced on an as needed bases, except for cooling fans, which should be replaced once the luminaries reach 10,000-hours. This is a prophylactic measure intended to keep the unit running as cool as possible, insuring proper function of all internal components. A complete service breakdown is available, please contact [service@adj.com](mailto:service@adj.com) for any needed parts or manuals.

# LIMITED WARRANTY (USA ONLY)

- A. ADJ Products, LLC hereby warrants, to the original purchaser, ADJ Products, LLC products to be free of manufacturing defects in material and workmanship for a prescribed period from the date of purchase (see specific warranty period on reverse). This warranty shall be valid only if the product is purchased within the United States of America, including possessions and territories. It is the owner's responsibility to establish the date and place of purchase by acceptable evidence, at the time service is sought.
- B. For warranty service, you must obtain a Return Authorization number (RA#) before sending back the product-please contact ADJ Products, LLC Service Department at 800-322-6337. Send the product only to the ADJ Products, LLC factory. All shipping charges must be pre-paid. If the requested repairs or service (including parts replacement) are within the terms of this warranty, ADJ Products, LLC will pay return shipping charges only to a designated point within the United States. If the entire instrument is sent, it must be shipped in its original package. No accessories should be shipped with the product. If any accessories are shipped with the product, ADJ Products, LLC shall have no liability whatsoever for loss of or damage to any such accessories, or for the safe return thereof.
- C. This warranty is void if the serial number has been altered or removed; if the product is modified in any manner which ADJ Products, LLC concludes, after inspection, affects the reliability of the product, if the product has been repaired or service by anyone other than ADJ Products, LLC factory unless prior written authorization was issued to purchaser by ADJ Products, LLC; if the product is damaged because not properly maintained as set forth in the instruction manual.
- D. This is not a service contract, and this warranty does not include maintenance, cleaning or periodic check up. During the period specified above, ADJ Products, LLC will replace defective parts at its expense with new or refurbished parts, and will absorb all expenses for warranty service and repair labor by reason of defects in material or workmanship. The sole responsibility of ADJ Products, LLC under this warranty shall be limited to the repair of the product, or replacement thereof, including parts, at the sole discretion of ADJ Products, LLC. All products covered by this warranty were manufactured after August 15, 2012, and bear identifying marks to that effect.
- E. ADJ Products, LLC reserves the right to make changes in design and/or improvements upon its products without any obligation to include these changes in any products theretofore manufactured.
- F. No warranty, whether expressed or implied, is given or made with respect to any accessory supplied with products described above. Except to the extent prohibited by applicable law, all implied warranties made by ADJ Products, LLC in connection with this product, including warranties of merchantability or fitness, are limited in duration to the warranty period set forth above. And no warranties, whether expressed or implied, including warranties of merchantability or fitness, shall apply to this product after said period has expired. The consumer's and/or Dealer's sole remedy shall be such repair or replacement as is expressly provided above; and under no circumstances shall ADJ Products, LLC be liable for any loss or damage, direct or consequential, arising out of the use of, or inability to use, this product.
- G. This warranty is the only written warranty applicable to ADJ Products, LLC Products and supersedes all prior warranties and written descriptions of warranty terms and conditions heretofore published.

## LIMITED WARRANTY PERIODS

- **Non L.E.D. Lighting Products = 1-year (365 days) Limited Warranty** (Such as: Special Effect Lighting, Intelligent Lighting, UV lighting, Strobes, Fog Machines, Bubble Machines, Mirror Balls, Par Cans, Trussing, Lighting Stands etc. excluding LED and lamps)
- **Laser Products = 1 Year (365 Days) Limited Warranty** (excludes laser diodes which have 6 month limited warranty)
- **L.E.D. Products = 2-year (730 days) Limited Warranty** (excluding batteries which have a 180 day limited warranty)  
Note: 2 Year Warranty only applies to purchases within the United States.
- **StarTec Series = 1 Year Limited Warranty** (excluding batteries which have a 180 day limited warranty)
- **ADJ DMX Controllers = 2 Year (730 Days) Limited Warranty**

# WARRANTY REGISTRATION

The Encore FR Pro Color carries a 2 year limited warranty. Please fill out the enclosed warranty card to validate your purchase. All returned service items, whether under warranty or not, must be freight pre-paid and accompanied by a return authorization (R.A.) number. The R.A. number must be clearly written on the outside of the return package. A brief description of the problem as well as the R.A. number must also be written down on a piece of paper included in the shipping carton. If the unit is under warranty, you must provide a copy of your proof of purchase invoice. You may obtain an R.A. number by contacting our customer support team on our customer support number. All packages returned to the service department not displaying an R.A. number on the outside of the package will be returned to the shipper.

# SAFETY GUIDELINES

THIS FIXTURE IS COMPOSED OF SOPHISTICATED ELECTRONIC COMPONENTS. TO GUARANTEE SMOOTH OPERATION, IT IS IMPORTANT TO FOLLOW ALL INSTRUCTIONS AND GUIDELINES IN THIS MANUAL. ADJ PRODUCTS, LLC IS NOT RESPONSIBLE FOR INJURY AND/OR DAMAGES RESULTING FROM THE MISUSE OF THIS FIXTURE DUE TO THE DISREGARD OF THE INFORMATION PRINTED IN THIS MANUAL. ONLY QUALIFIED AND/OR CERTIFIED PERSONNEL SHOULD PERFORM INSTALLATION OF THIS FIXTURE AND ONLY THE ORIGINAL RIGGING PARTS INCLUDED WITH THIS FIXTURE SHOULD BE USED FOR INSTALLATION. ANY MODIFICATIONS TO THE FIXTURE AND/OR THE INCLUDED MOUNTING HARDWARE WILL VOID THE ORIGINAL MANUFACTURER'S WARRANTY AND INCREASE THE RISK OF DAMAGE AND/OR PERSONAL INJURY. ONLY CERTIFIED PERSONNEL SHOULD PERFORM INSTALLATION OF THIS FIXTURE.

- PROTECTION CLASS 1 - FIXTURE MUST BE PROPERLY GROUNDED.
- THERE ARE NO USER SERVICEABLE PARTS INSIDE THIS UNIT.
- DO NOT ATTEMPT ANY REPAIRS YOURSELF; DOING SO WILL VOID YOUR MANUFACTURER'S WARRANTY. DAMAGES RESULTING FROM MODIFICATIONS TO THIS FIXTURE AND/OR THE DISREGARD OF SAFETY INSTRUCTIONS AND GUIDELINES IN THIS MANUAL VOID THE MANUFACTURER'S WARRANTY AND ARE NOT SUBJECT TO ANY WARRANTY CLAIMS AND/OR REPAIRS.
- DO NOT PLUG FIXTURE INTO A DIMMER PACK!
- NEVER OPEN THIS FIXTURE WHILE IN USE!
- UNPLUG POWER BEFORE SERVICING FIXTURE!
- NEVER TOUCH FIXTURE DURING OPERATION, AS IT MAY BE HOT!
- KEEP FLAMMABLE MATERIALS AWAY FROM FIXTURE!
- NEVER LOOK DIRECTLY INTO THE LIGHT SOURCE!
- RETINA INJURY RISK - MAY INDUCE BLINDNESS!
- SENSITIVE PERSONS MAY SUFFER AN EPILEPTIC SHOCK!
- MINIMUM DISTANCE TO OBJECTS/SURFACES IS 6.6 FEET (2 METERS)
- **MAXIMUM AMBIENT TEMPERATURE IS 113° F (45°C). DO NOT OPERATE THE DEVICE WHEN AMBIENT TEMPERATURE EXCEEDS THIS VALUE.**
- **MINIMUM DISTANCE TO FLAMMABLE MATERIALS FROM THE SURFACE IS 1.6 FEET (0.5 METER).** DO NOT TOUCH the fixture housing during operation. Turn OFF the power and allow approximately 60 minutes for the fixture to cool down before servicing.
- DO NOT shake fixture, and avoid brute force when installing and/or operating fixture.
- DO NOT operate fixture if the power cord is frayed, crimped, damaged and/or if any of the power cord connectors are damaged and do not insert into the fixture securely with ease. NEVER force a power cord connector into the fixture. If the power cord or any of its connectors are damaged, replace it immediately with a new one of the same power rating.
- DO NOT block any air ventilation slots. All fan and air inlets must remain clean and never blocked. Allow approx. 6" (15cm) between fixture and other devices or a wall for proper cooling.
- When installing fixture in a suspended environment, always use mounting hardware that is no less than M10 x 25 mm, and always install fixture with an appropriately rated safety cable.
- Always disconnect fixture from main power source before performing any type of service and/or cleaning procedure.
- Only handle the power cord by the plug end. Never pull out the plug by tugging the wire portion of the cord.
- During the initial operation of this fixture, a light smoke or smell may emit from the interior of the fixture. This is a normal process and is caused by excess paint in the interior of the casing burning off from the heat associated with the lamp and will decrease gradually over time.
- Consistent operational breaks will ensure fixture will function properly for many years.
- ONLY use original packaging and materials to transport the fixture for service.

# OVERVIEW

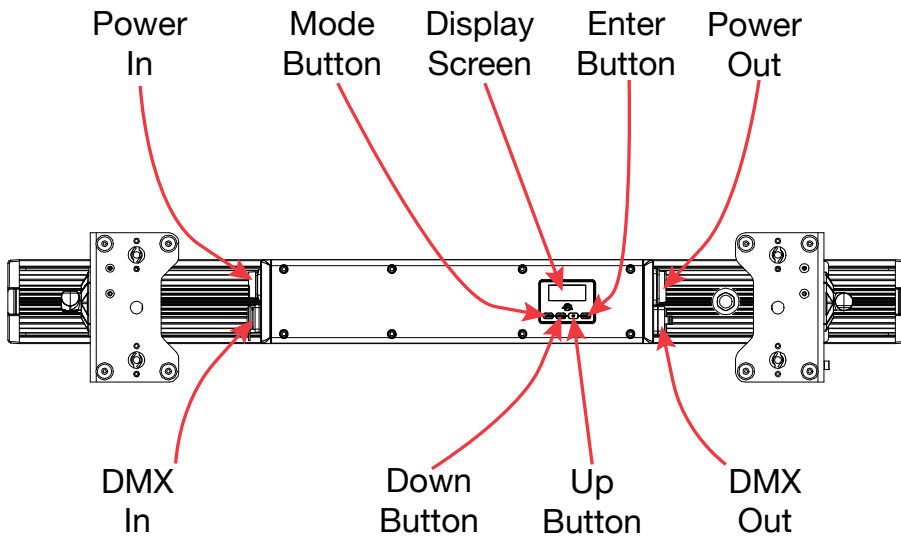
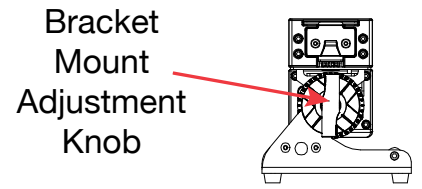
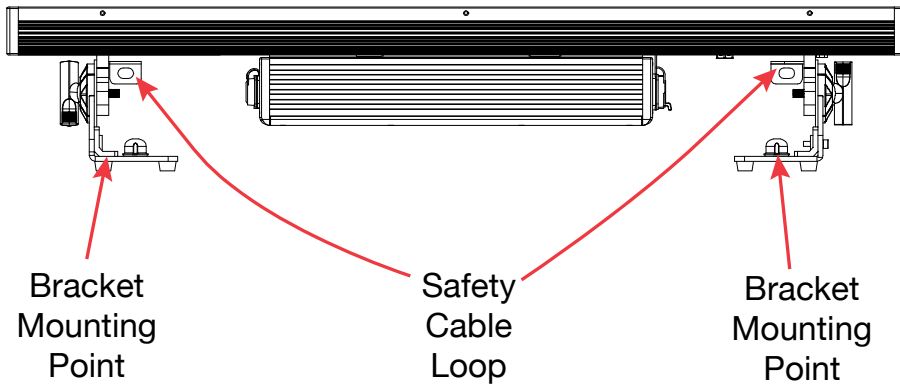

# INSTALLATION



## **FLAMMABLE MATERIAL WARNING**

Keep fixture minimum 5.0 feet (1.5m) away from flammable materials and/or pyrotechnics.



## **ELECTRICAL CONNECTIONS**

A qualified electrician should be used for all electrical connections and/or installations.



## **MINIMUM DISTANCE TO OBJECTS/SURFACES IS 6.6 FEET (2 METERS).**

**MINIMUM DISTANCE OF FLAMMABLE MATERIALS FROM THE SURFACE IS 1.6 FEET (0.5 METER)**

## **DO NOT INSTALL THE FIXTURE IF YOU ARE NOT QUALIFIED TO DO SO!**

- Fixture **MUST** be installed following all local, national, and country commercial electrical and construction codes and regulations.
- Before rigging/mounting a single fixture or multiple fixtures to any metal truss/structure or placing the fixture(s) on any surface, a professional equipment installer **MUST** be consulted to determine if the metal truss/structure or surface is properly certified to safely hold the combined weight of the fixture(s), clamps, cables, and accessories.
- Maximum fixture ambient operating temperature is **113°F (45°C)**. Do not use operate the fixture when ambient temperature exceeds this value!
- Fixture(s) should be installed outside walking paths, seating areas, or areas were unauthorized personnel might reach the fixture by hand.
- **NEVER** stand directly below the fixture(s) when rigging, removing, or servicing.
- Overhead fixture installation must always be secured with a secondary safety attachment, such as an appropriately rated safety cable.
- Allow approximately 60 minutes for the fixture to cool down before servicing.

## **IP RATING**

**This device is IP65 rated. This means that the unit is dust-tight, and protected against low-pressure jets of water from any direction.**

## **RIGGING**

**Overhead rigging requires extensive experience, including calculating working load limits, knowledge about installation materials being used, and periodic safety inspection of all installation material and the fixture, among other skills. If you lack these qualifications, do not attempt the installation yourself. Improper installation can result in bodily injury.**

## **END CAP CONNECTIONS**

**Ensure ALL connections and end caps are properly sealed with a non-conductive dielectric grease (available at most electrical suppliers) to prevent water ingress/condensation and/or corrosion.**

# INSTALLATION

## CLAMP INSTALLATION

This fixture features an attachment point for a mounting clamp located at the top the mounting bracket. There is also a loop for the attachment of a safety cable located on the rear of the fixture, just above the carrying handle (see the illustration below). When mounting the fixture to a truss or any other suspended or overhead installation, be sure to secure an appropriately rated clamp (not included) to the mounting bracket, and attach a separate **SAFETY CABLE** of the appropriate weight rating to the safety cable loop. **Please note that when the available barndoor is fitted, the barndoor must be secured with its own separate safety cable.**

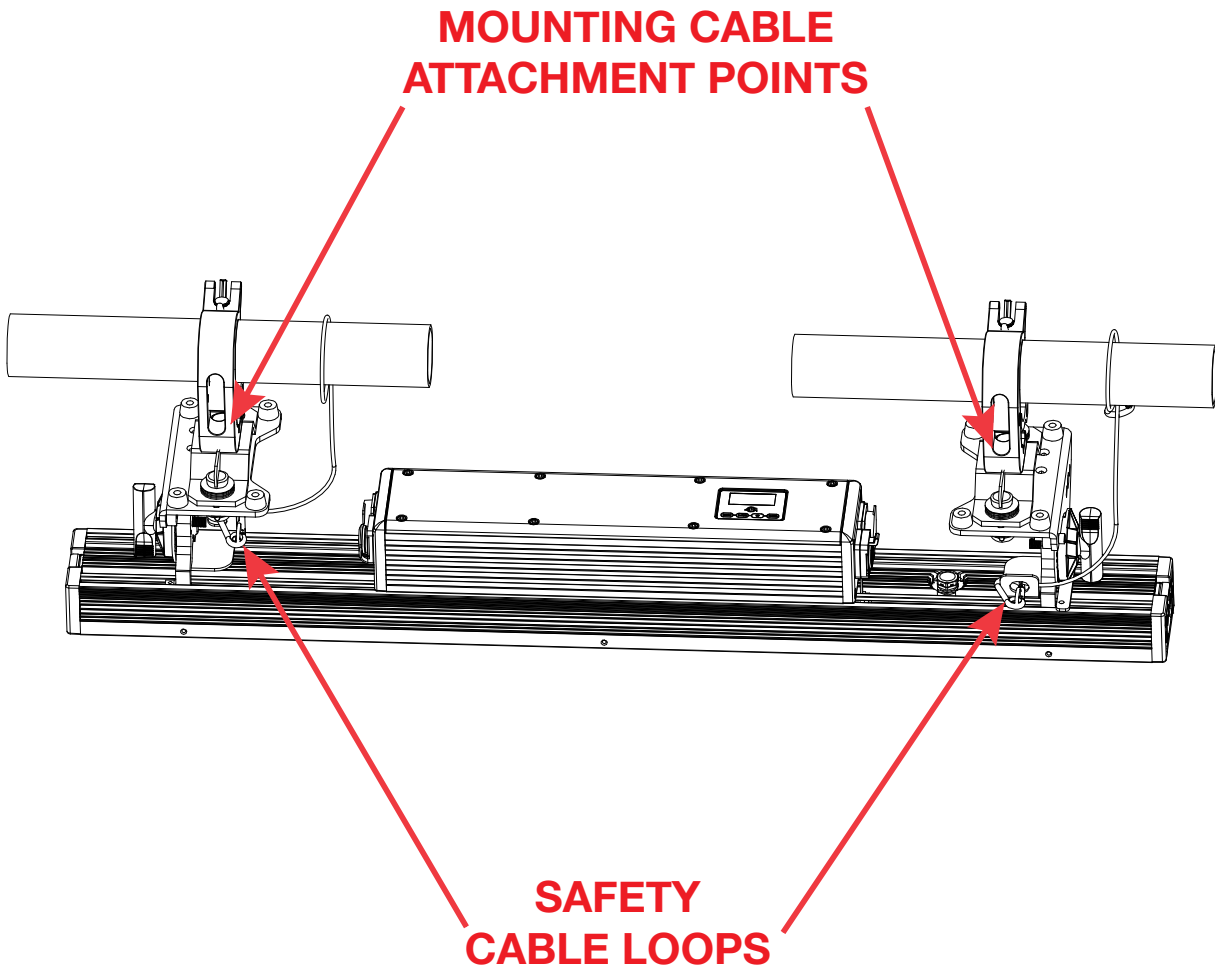

**SAFETY CABLE:  
ALWAYS ATTACH A SAFETY CABLE WHENEVER INSTALLING THIS FIXTURE  
IN A SUSPENDED ENVIRONMENT TO ENSURE THAT THE FIXTURE WILL NOT  
FALL IF THE CLAMP FAILS.**

# INSTALLATION

## POTENTIAL INTERNAL FIXTURE DAMAGE FROM EXTERNAL SOURCES OF LIGHT BEAMS

External sources of light beams from direct sunlight, lighting moving head fixtures, and lasers which are focused directly towards the exterior housing and/or penetrate the front lens opening of ADJ lighting fixtures can cause severe internal damage, including burning of optics, dichroic color filters, glass and metal gobos, prisms, animation wheels, frost filters, irises, shutters, motors, belts, wiring, discharge lamps, and LEDs.

This issue is not unique to ADJ lighting fixtures, but rather it is a common issue with lighting fixtures from all manufacturers. Although there is no true way to completely prevent this issue from occurring, the guidelines below can reduce the risk of any potential damage if followed. Contact ADJ Service for more details.

**DO NOT EXPOSE THE FIXTURE AND/OR FRONT LENS OPENING TO LIGHT BEAMS FROM DIRECT SUNLIGHT, OTHER LIGHTING OR MOVING HEAD FIXTURES, AND LASERS DURING UNPACKING, INSTALLATION, USE, AND EXTENDED IDLE TIMES OUTDOORS. DO NOT FOCUS A LIGHT BEAM FROM ONE LIGHTING FIXTURE DIRECTLY TOWARDS ANOTHER.**

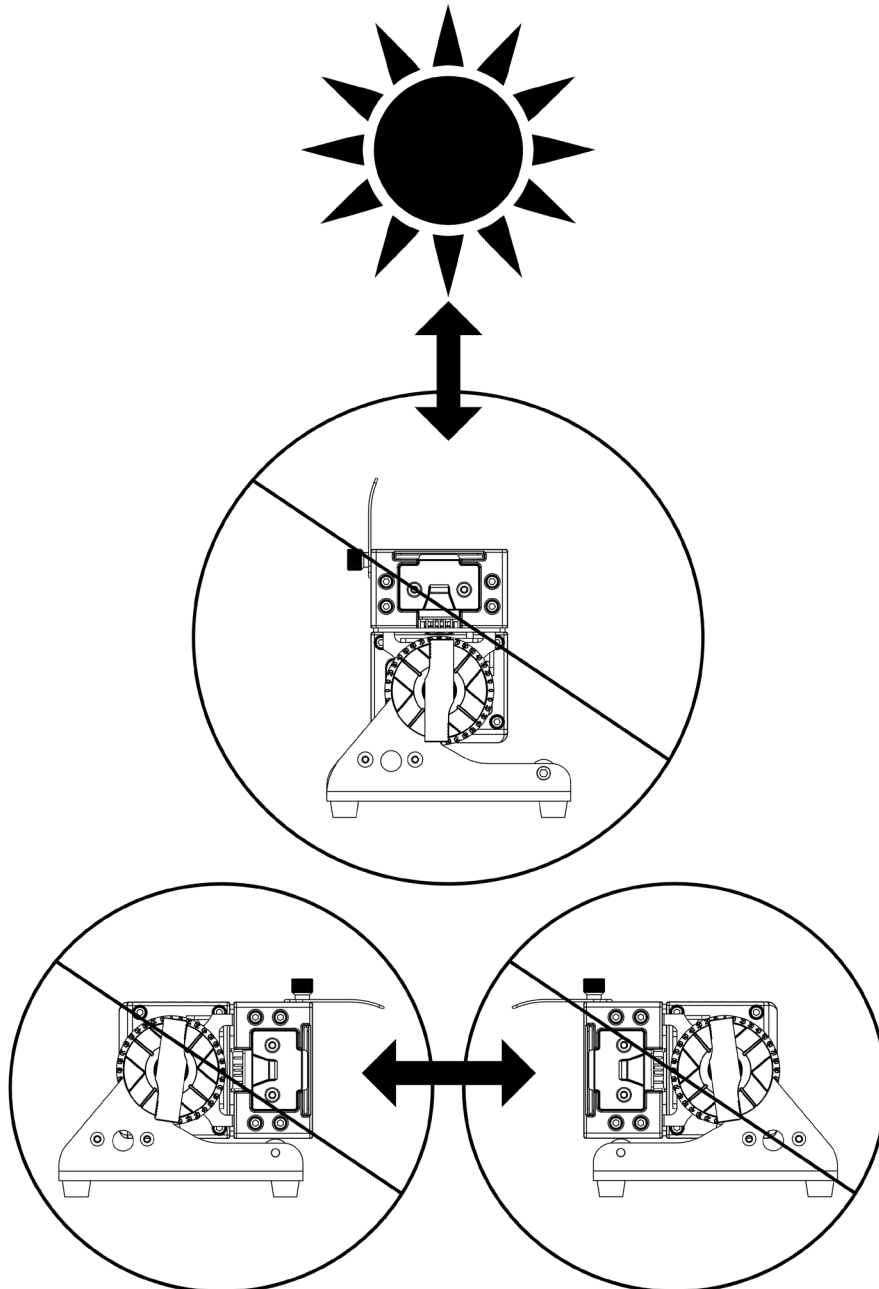

# MANUAL TILT ADJUSTMENT

The bar angle is adjustable manually using the brackets located on each side of the unit. Simply loosen the tilt adjustment knobs attached to each mounting bracket and adjust the bracket accordingly. After making your desired set up, securely tighten the tilt adjustment knobs. The image below illustrates a 90-degree configuration.

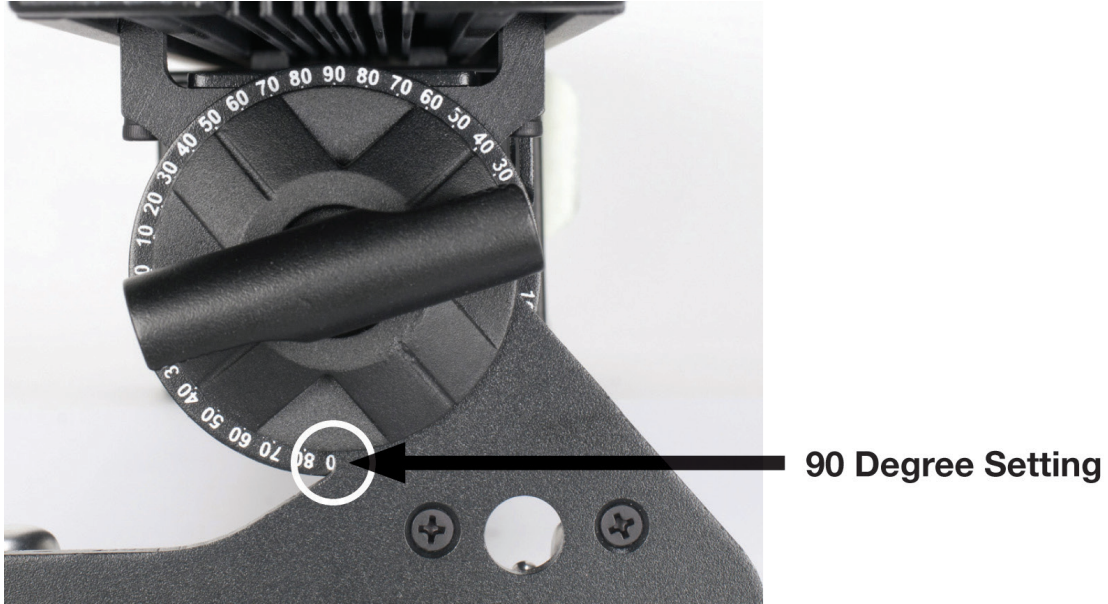

# ACCESSORY INSTALLATION

## FROST FILTER

In order to install the included frost filter, find the latch located at the end of the light bar. Press down on the latch, and continue to hold it down as the frost filter is inserted into place in the lens frame slot, as shown in the illustration below. When the frost filter has been fully inserted, release the latch to secure the frost filter in place.

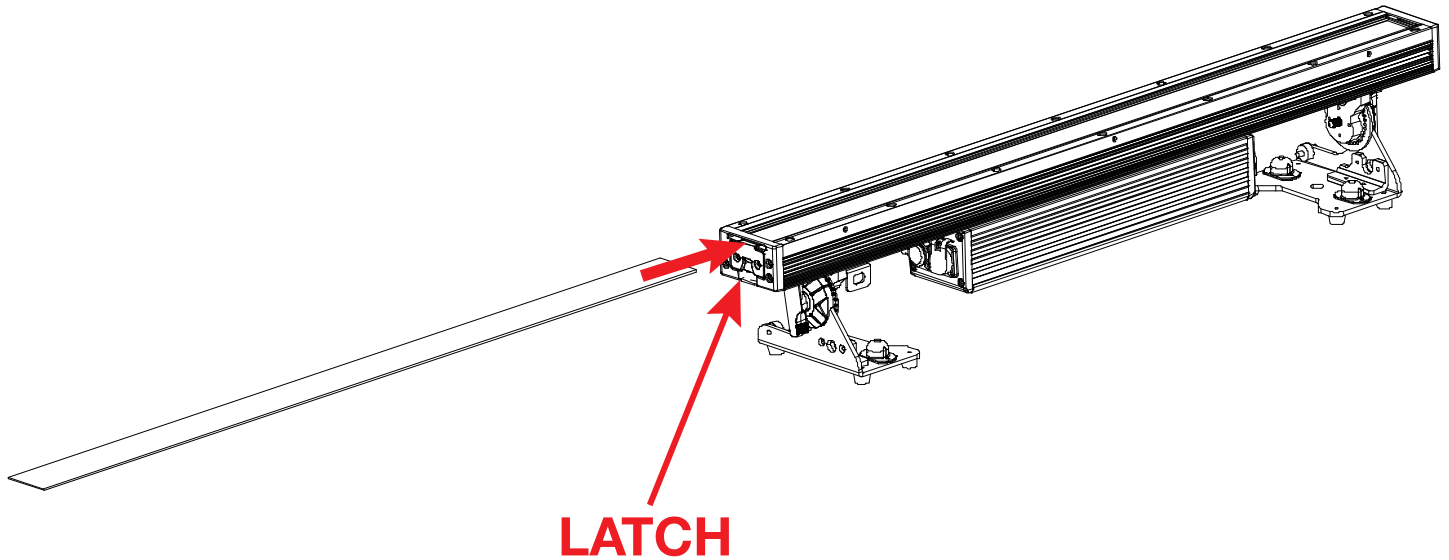

## GLARE SHIELD

In order to install the included glare shield, begin by locating the three (3) screw holes located along the long side of the lens frame. Align these lens frame holes with the holes on the glare shield, then insert a screw through each hole. Tighten the screws to secure the glare shield in place.

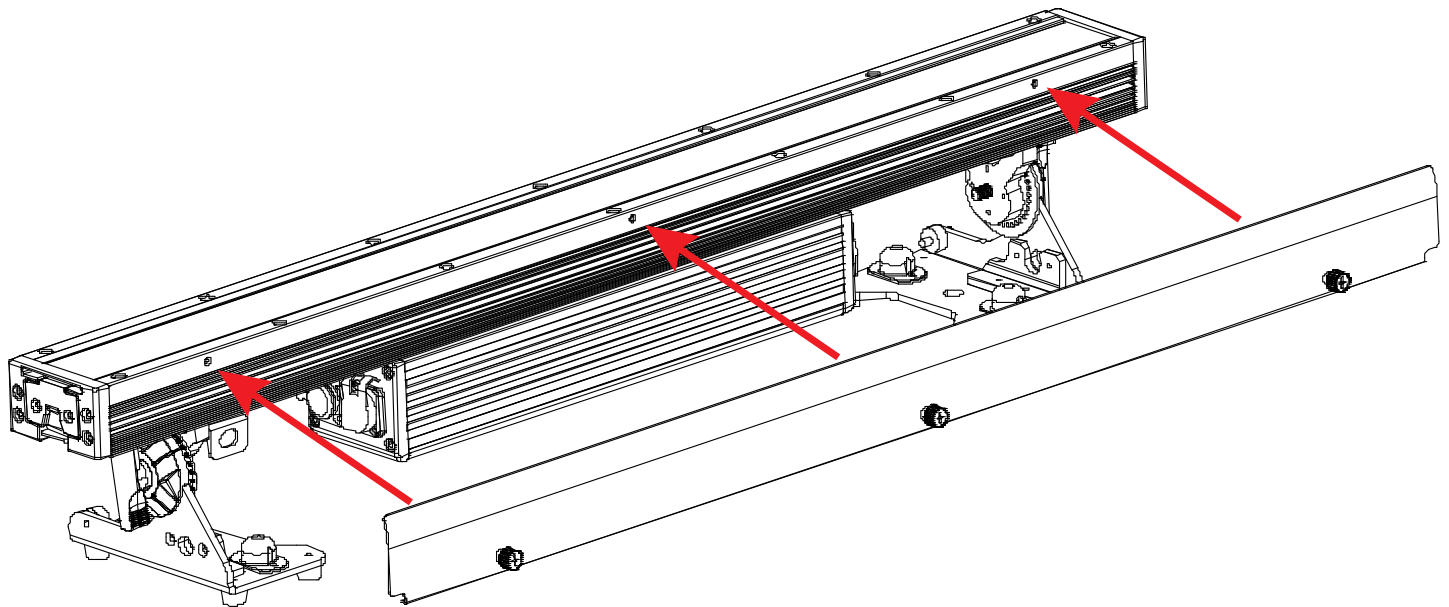

# REMOTE DEVICE MANAGEMENT (RDM)

**NOTE: In order for RDM to work properly, RDM enabled equipment must be used throughout the entire system, including DMX data splitters and wireless systems.**

Remote Device Management (RDM) is a protocol that sits on top of the DMX512 data standard for lighting, allowing the DMX systems of the fixtures to be modified and monitored remotely. This protocol is ideal for instances in which a unit is installed in a location that is not easily accessible.

With RDM, the DMX512 system becomes bi-directional, allowing a compatible RDM enabled controller to send out a signal to devices on the wire, as well as allowing the fixture to respond (known as a GET command). The controller can then use its SET command to modify settings that would typically have to be changed or viewed directly via the unit's display screen, including the DMX Address, DMX Channel Mode, and Temperature Sensors.

## FIXTURE RDM INFORMATION

RDM Code	Device ID	Model ID	Personality ID
1900	0051 xxxx	81	[001] 4ch, [002] 7ch, [003] 8ch, [004] 14ch, [005] 16ch, [006] 60ch, [007] 63ch, [008] 69ch, [009] 72ch, [010] 120ch

Please be aware that **not all RDM devices support all RDM features**, and therefore it is important to check beforehand to ensure that the equipment that you are considering includes all of the features that you require.

The following parameters are accessible in RDM on this device:

[0x0011] Proxied Device Count	[0x0405] Device Power Cycles
[0x0200] Sensor Definition	[0x0600] Pan Invert
[0x0201] Sensor Value	[0x0601] Tilt Invert
[0x0080] Device Model Description	[0x0602] Pan Tilt Swap
[0x0081] Manufacturer Label	[0x0500] Display Invert
[0x0082] Device Label	[0x0501] Display Level
[0x00E0] DMX Personality	[0x0603] Realtime Clock
[0x00E1] DMX Personality Description	[0x1010] Power State
[0x0400] Device Hours	[0x1031] Preset Playback
[0x0015] Comms Status	[0x0122] Default Slot Value
[0x0031] Status ID Description	[0x00B0] Language
[0x0032] Clear Status ID	[0x00A0] Language Capabilities
[0x0401] Lamp Hours	[0x00C2] Boot Software Version Label
[0x0402] Lamp Strikes	[0x00C1] Boot Software Version ID
[0x0403] Lamp State	[0x0070] Product Detail ID List
[0x0404] Lamp Mode	

# WIFLY GUIDELINES

## WIRELESS SETUP

There are many factors that can affect and/or interrupt a wireless signal, including walls, glass, metal, objects, and people. Therefore, the following guidelines are recommended in order to maximize the chances of having a clear path for the wireless signal to reach the device:

- Install the device a minimum of 9.8 ft (3m) above audiences and/or ground level.
- Arrange the wireless antenna in an upright, vertical position.
- Position devices in direct line of sight of the transmitting controller.

Careful planning and testing of the selected installation location is critical in order to ensure optimized, reliable wireless operation.

**9.8 ft (3m)  
Above Ground**

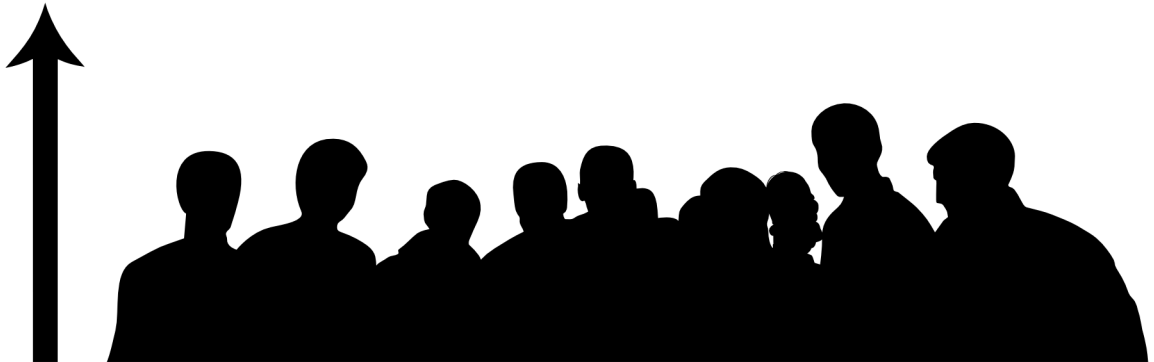

# CONTROL PANEL

The fixture includes an easy to navigate system menu control panel display where all necessary settings and adjustments are made. (See image below)

- **MODE:** Cycles through the main menu options and/or return to previous menu without making changes.
- **DOWN/UP:** Scroll through options in the selected menu.
- **ENTER:** Select highlighted option and/or confirm selection.

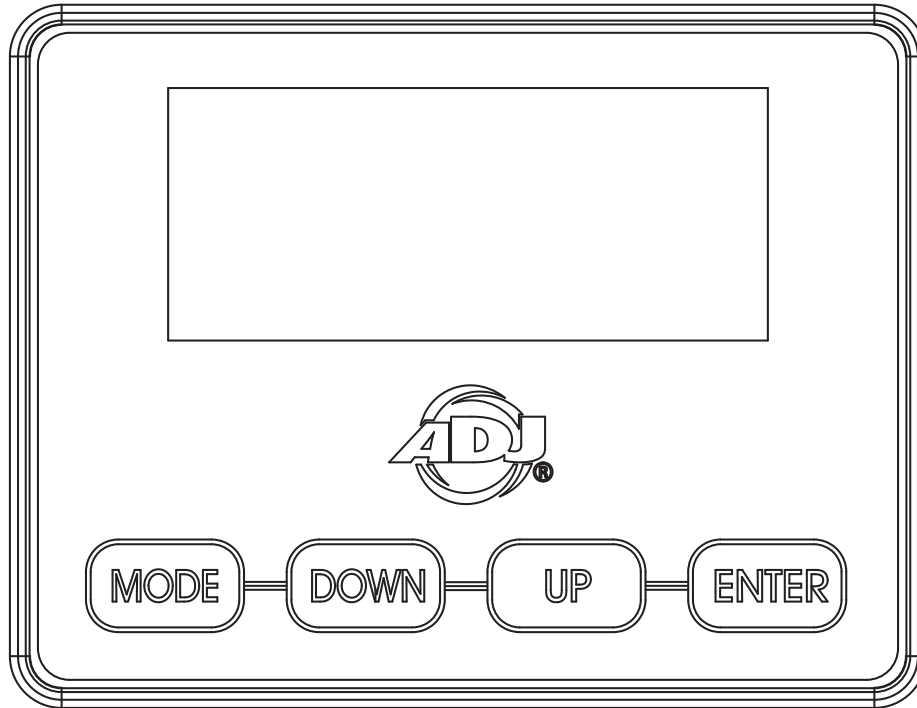

## DISPLAY SCREEN LOCK

When the Display Lock setting is set to 1~10min, the display screen will automatically lock if there is no activity for the specified length of time. To unlock the display screen, simply press and hold the MODE button for 3 seconds.

Alternately, when the Display Lock setting is set to OFF, the display screen will never automatically lock. However, it can still be manually locked by pressing and holding the MODE button for 2 seconds. To unlock, press and hold the MODE button for 3 seconds.

# SYSTEM MENU

DMX SET	Address	<b>001</b> - 512		Set DMX address	
	Ch. Mode	4ch		Set DMX channel mode	
		7ch			
		8ch			
		<b>13ch</b>			
		16ch			
		60ch			
		63ch			
		69ch			
		72ch			
		120ch			
	No DMX	<b>Hold</b>		Holds last settings if DMX signal is lost	
		Blackout		Takes all channels to 0 if DMX signal is lost	
		Manual		Defaults to manual mode setting if DMX signal is lost	
Internal Programs		Defaults to most recently selected internal program if DMX signal is lost			
PERSONALITY	Prim/Sec Mode	Primary / <b>Secondary</b>			
	Select Signal	DMX or Wifly		DMX has priority; green LED = Wifly connected; red LED = Wifly not connected	
		Wifly and DMX Out		DMX XLR shall send signal out; green LED = Wifly connected	
	Wifly Settings	Wifly Enable	<b>On</b> / Off		
		Set Wifly Channel	00 - 14		
	Pixel Flip	<b>1-15</b>		Pixel Flip off	
		15-1		Pixel Flip on	
	Fan Set	<b>Auto</b>			
		High			
		Silent			

# SYSTEM MENU

<b>PERSONALITY (continued)</b>	Dim Mode	<b>Standard</b>			
		Stage			
		TV			
		Archi.			
		Theatre			
		Stage 2			
		Dim Speed	0.1s ~ 10s		
	Dim Curve	Linear			
		<b>Square</b>			
		Inv. Squa.			
		S. Curve			
	LED Rfrsh	900Hz, 1000Hz, 1100Hz, <b>1200Hz</b> , 1300Hz, 1400Hz, 1500Hz, 2500Hz, 4000Hz, 5000Hz, 10KHz, 15KHz, 20KHz, 25KHz			
	Display	Save Dlay	1-10		
		Lock	<b>Off</b> , 1min-10min		
	Service	Passcode = 050	Calibrat	All Red 000 - 255	
				All Green 000 - 255	
				All Blue 000 - 255	
				All Lime 000 - 255	
				Red1 000 - 255	
				Green1 000 - 255	
Blue1 000 - 255					
Lime1 000 - 255					
...					
Red15 000 - 255					
Green15 000 - 255					
Blue15 000 - 255					
Lime15 000 - 255					

# SYSTEM MENU

<b>PERSONALITY (continued)</b>	Service (continued)	Passcode = 050	USB Power	On / <b>Off</b>		
			Software Update	Yes / <b>No</b>		
			Restore	Yes / <b>No</b>		
<b>MANUAL</b>	Red	000 - 255		Manually adjust red		
	Blue	000 - 255		Manually adjust green		
	Green	000 - 255		Manually adjust blue		
	Lime	000 - 255		Manually adjust lime		
	ClrMacro	00 - 64		Select color macro		
	ClrTemp	000 - 255		Set color temperature		
	Strobe	000 - 255		Select strobe setting		
	MastrDim	000 - 255		Set master dimmer		
	AutoProg	000 - 255		Select Auto Program		
	ProgSpd	000 - 255		Set program speed		
	ProgFade	000 - 255		Set program fade		
<b>INTPROGS</b>	Prog 0	Speed	000 - 255			
		Fade	000 - 255			
		Sound	On / <b>Off</b>	000 - 255		
	Prog 1	Speed	000 - 255			
		Fade	000 - 255			
		Sound	On / <b>Off</b>	000 - 255		
	...	...	...			
	Prog 13	Speed	000 - 255			
		Fade	000 - 255			
		Sound	On / <b>Off</b>	000 - 255		
	<b>INFO</b>	Hours	PwrOnHr1	xxxxxx Hours		Total hours fixture has been powered on. Non resettable
			PwrOnHr2	xxxxxx Hours		Number of hours fixture has been powered on since last reset. Resettable
PwrOnRst			Passcode = 050		Reset power on time	
Temp		xxx°	xxx F / xxx C		Current LED temp	
		MaxTemp1	xxx F / xxx C		Current max LED temp since last reset. Resettable	
		MaxTemp2	xxx F / xxx C		All time max LED temp. Non resettable	
		Temp Rst.	Yes / <b>No</b>	Passcode = 050	Reset LED temp	
Humidity		xxx %		Current head humidity		

# SYSTEM MENU

<b>INFO (continued)</b>	Fan Info	Fan1 RPM	xxxx	
		Fan2 RPM	xxxx	
	DMX Values	Red		Displays current DMX value for each channel
		Green		
		...		
	AutoProg			
	SoftVers	x.xx		

# DMX SETUP

**DMX-512:** DMX is short for Digital Multiplex. This is a universal protocol used as a form of communication between intelligent fixtures and controllers. A DMX controller sends DMX data instructions from the controller to the fixture. DMX data is sent as serial data that travels from fixture to fixture via the DATA “IN” and DATA “OUT” XLR terminals located on all DMX fixtures (most controllers only have a DATA “OUT” terminal).

**DMX Linking:** DMX is a language allowing all makes and models of different manufacturers to be linked together and operate from a single controller, as long as all fixtures and the controller are DMX compliant. To ensure proper DMX data transmission, try to use the shortest cable path possible when using several DMX fixtures. The order in which fixtures are connected in a DMX line does not influence the DMX addressing. For example, a fixture assigned a DMX address of 1 may be placed anywhere in a DMX line: at the beginning, at the end, or anywhere in the middle. When a fixture is assigned a DMX address of 1, the DMX controller knows to send DATA assigned to address 1 to that unit, no matter where it is located in the DMX chain.

**Data Cable (DMX Cable) Requirements (For DMX Operation):** The Encore LB15IP can be controlled via DMX-512 protocol, and features multiple DMX channel modes. Your unit and your DMX controller require a 5-pin XLR connector for data input and data output. If you are making your own cables, be sure to use standard 110-120 Ohm shielded cable (This cable may be purchased at almost all professional lighting stores). Your cables should be made with a male XLR connector at one end and a female XLR connector at the other. Also remember that DMX cable must be daisy chained and cannot be split.

**Special Note: Line Termination.** When longer runs of cable are used, you may need to use a terminator on the last unit to avoid erratic behavior. A terminator is a 110-120 ohm 1/4 watt resistor which is connected between pins 2 and 3 of a male XLR connector (DATA + and DATA -). This unit is inserted in the female XLR connector of the last unit in your daisy chain to terminate the line. Using a cable terminator (ADJ part number Z-DMX/T) will decrease the chances of erratic behavior.

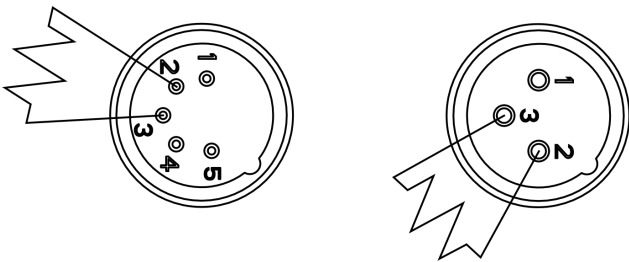

A DMX512 terminator reduces signal errors, avoiding most signal reflection interference. Connect PIN 2 (DMX-) and PIN 3 (DMX+) of the last fixture in series with a 120 Ohm, 1/4 W Resistor to terminate the DMX512.

# DMX SETUP

## DMX ADDRESSING

All fixtures should be given a DMX starting address when operating with a DMX controller, in order to ensure that the correct fixture responds to the correct control signal. This digital starting address is the channel number from which the fixture starts to “listen” to the digital control signal sent out from the DMX controller. The starting DMX address is configured by setting the correct DMX address on the control panel display on the fixture.

You can set the same starting address for multiple fixtures, or set different addresses for each individual fixture. Setting multiple fixtures to the same DMX address will cause all those fixtures to react in the same way. In this case, please note that changing the settings of one channel will affect all the fixtures simultaneously.

If you set each fixture to a different DMX address, each unit will start to “listen” to the channel number you have set, based on the quantity of DMX channels of each fixture. That means changing the settings of one channel will only affect the selected fixture.

As an example, when operating this device in 4 channel mode, you should set the starting DMX address of the first unit to 1, the second unit to 5 (1 + 4), the third unit to 9 (1 + 4 + 4), and so on. (See the chart below for more details.)

Channel Mode	Unit 1 Address	Unit 2 Address	Unit 3 Address	Unit 4 Address
4 Channels	1	5	9	13
7 Channels	1	8	15	22
8 Channels	1	9	17	25
13 Channels	1	14	27	40
16 Channels	1	17	33	49
60 Channels	1	61	121	181
63 Channels	1	64	127	190
69 Channels	1	70	139	208
72 Channels	1	73	145	217
120 Channels	1	121	241	361

# DMX TRAITS

CHANNEL										DMX VALUE	FUNCTION
4 CH	7 CH	8 CH	13 CH	16 CH	60 CH	63 CH	69 CH	72 CH	120 CH		
1	1	1	1	1						000 - 255	<b>All Red</b> , 0% to 100%
		2								000 - 255	<b>All Red Fine</b>
2	2	3	2	2						000 - 255	<b>All Green</b> , 0% to 100%
		4								000 - 255	<b>All Green Fine</b>
3	3	5	3	3						000 - 255	<b>All Blue</b> , 0% to 100%
		6								000 - 255	<b>All Blue Fine</b>
4	4	7	4	4						000 - 255	<b>All Lime</b> , 0% to 100%
		8								000 - 255	<b>All Lime Fine</b>
					1	1	1	1	1	000 - 255	<b>Red1</b> , 0% to 100%
									2	000 - 255	<b>Red1 Fine</b>
					2	2	2	2	3	000 - 255	<b>Green1</b> , 0% to 100%
									4	000 - 255	<b>Green1 Fine</b>
					3	3	3	3	5	000 - 255	<b>Blue1</b> , 0% to 100%
									6	000 - 255	<b>Blue1 Fine</b>
					4	4	4	4	7	000 - 255	<b>Lime1</b> , 0% to 100%
									8	000 - 255	<b>Lime1 Fine</b>
					5	5	5	5	9	000 - 255	<b>Red2</b> , 0% to 100%
									10	000 - 255	<b>Red2 Fine</b>
					6	6	6	6	11	000 - 255	<b>Green2</b> , 0% to 100%
									12	000 - 255	<b>Green2 Fine</b>
					7	7	7	7	13	000 - 255	<b>Blue2</b> , 0% to 100%
									14	000 - 255	<b>Blue2 Fine</b>
					8	8	8	8	15	000 - 255	<b>Lime2</b> , 0% to 100%
									16	000 - 255	<b>Lime2 Fine</b>
					9	9	9	9	17	000 - 255	<b>Red3</b> , 0% to 100%
									18	000 - 255	<b>Red3 Fine</b>
					10	10	10	10	19	000 - 255	<b>Green3</b> , 0% to 100%
									20	000 - 255	<b>Green3 Fine</b>
					11	11	11	11	21	000 - 255	<b>Blue3</b> , 0% to 100%
									22	000 - 255	<b>Blue3 Fine</b>
					12	12	12	12	23	000 - 255	<b>Lime3</b> , 0% to 100%
									24	000 - 255	<b>Lime3 Fine</b>
					13	13	13	13	25	000 - 255	<b>Red4</b> , 0% to 100%
									26	000 - 255	<b>Red4 Fine</b>
					14	14	14	14	27	000 - 255	<b>Green4</b> , 0% to 100%

CONTINUED ON NEXT PAGE

# DMX TRAITS

CHANNEL										DMX VALUES	FUNCTION
4 CH	7 CH	8 CH	13 CH	16 CH	60 CH	63 CH	69 CH	72 CH	120 CH		
									28	000 - 255	<b>Green4 Fine</b>
					15	15	15	15	29	000 - 255	<b>Blue4, 0% to 100%</b>
									30	000 - 255	<b>Blue4 Fine</b>
					16	16	16	16	31	000 - 255	<b>Lime4, 0% to 100%</b>
									32	000 - 255	<b>Lime4 Fine</b>
					17	17	17	17	33	000 - 255	<b>Red5, 0% to 100%</b>
									34	000 - 255	<b>Red5 Fine</b>
					18	18	18	18	35	000 - 255	<b>Green5, 0% to 100%</b>
									36	000 - 255	<b>Green5 Fine</b>
					19	19	19	19	37	000 - 255	<b>Blue5, 0% to 100%</b>
									38	000 - 255	<b>Blue5 Fine</b>
					20	20	20	20	39	000 - 255	<b>Lime5, 0% to 100%</b>
									40	000 - 255	<b>Lime5 Fine</b>
					21	21	21	21	41	000 - 255	<b>Red6, 0% to 100%</b>
									42	000 - 255	<b>Red6 Fine</b>
					22	22	22	22	43	000 - 255	<b>Green6, 0% to 100%</b>
									44	000 - 255	<b>Green6 Fine</b>
					23	23	23	23	45	000 - 255	<b>Blue6, 0% to 100%</b>
									46	000 - 255	<b>Blue6 Fine</b>
					24	24	24	24	47	000 - 255	<b>Lime6, 0% to 100%</b>
									48	000 - 255	<b>Lime6 Fine</b>
					25	25	25	25	49	000 - 255	<b>Red7, 0% to 100%</b>
									50	000 - 255	<b>Red7 Fine</b>
					26	26	26	26	51	000 - 255	<b>Green7, 0% to 100%</b>
									52	000 - 255	<b>Green7 Fine</b>
					27	27	27	27	53	000 - 255	<b>Blue7, 0% to 100%</b>
									54	000 - 255	<b>Blue7 Fine</b>
					28	28	28	28	55	000 - 255	<b>Lime7, 0% to 100%</b>
									56	000 - 255	<b>Lime7 Fine</b>
					29	29	29	29	57	000 - 255	<b>Red8, 0% to 100%</b>
									58	000 - 255	<b>Red8 Fine</b>
					30	30	30	30	59	000 - 255	<b>Green8, 0% to 100%</b>
									60	000 - 255	<b>Green8 Fine</b>
					31	31	31	31	61	000 - 255	<b>Blue8, 0% to 100%</b>
									62	000 - 255	<b>Blue8 Fine</b>

CONTINUED ON NEXT PAGE

# DMX TRAITS

CHANNEL										DMX VALUES	FUNCTION
4 CH	7 CH	8 CH	13 CH	16 CH	60 CH	63 CH	69 CH	72 CH	120 CH		
					32	32	32	32	63	000 - 255	<b>Lime8</b> , 0% to 100%
									64	000 - 255	<b>Lime8 Fine</b>
					33	33	33	33	65	000 - 255	<b>Red9</b> , 0% to 100%
									66	000 - 255	<b>Red9 Fine</b>
					34	34	34	34	67	000 - 255	<b>Green9</b> , 0% to 100%
									68	000 - 255	<b>Green9 Fine</b>
					35	35	35	35	69	000 - 255	<b>Blue9</b> , 0% to 100%
									70	000 - 255	<b>Blue9 Fine</b>
					36	36	36	36	71	000 - 255	<b>Lime9</b> , 0% to 100%
									72	000 - 255	<b>Lime9 Fine</b>
					37	37	37	37	73	000 - 255	<b>Red10</b> , 0% to 100%
									74	000 - 255	<b>Red10 Fine</b>
					38	38	38	38	75	000 - 255	<b>Green10</b> , 0% to 100%
									76	000 - 255	<b>Green10 Fine</b>
					39	39	39	39	77	000 - 255	<b>Blue10</b> , 0% to 100%
									78	000 - 255	<b>Blue10 Fine</b>
					40	40	40	40	79	000 - 255	<b>Lime10</b> , 0% to 100%
									80	000 - 255	<b>Lime10 Fine</b>
					41	41	41	41	81	000 - 255	<b>Red11</b> , 0% to 100%
									82	000 - 255	<b>Red11 Fine</b>
					42	42	42	42	83	000 - 255	<b>Green11</b> , 0% to 100%
									84	000 - 255	<b>Green11 Fine</b>
					43	43	43	43	85	000 - 255	<b>Blue11</b> , 0% to 100%
									86	000 - 255	<b>Blue11 Fine</b>
					44	44	44	44	87	000 - 255	<b>Lime11</b> , 0% to 100%
									88	000 - 255	<b>Lime11 Fine</b>
					45	45	45	45	89	000 - 255	<b>Red12</b> , 0% to 100%
									90	000 - 255	<b>Red12 Fine</b>
					46	46	46	46	91	000 - 255	<b>Green12</b> , 0% to 100%
									92	000 - 255	<b>Green12 Fine</b>
					47	47	47	47	93	000 - 255	<b>Blue12</b> , 0% to 100%
									94	000 - 255	<b>Blue12 Fine</b>
					48	48	48	48	95	000 - 255	<b>Lime12</b> , 0% to 100%
									96	000 - 255	<b>Lime12 Fine</b>
					49	49	49	49	97	000 - 255	<b>Red13</b> , 0% to 100%

CONTINUED ON NEXT PAGE

# DMX TRAITS

CHANNEL										DMX VALUES	FUNCTION
4 CH	7 CH	8 CH	13 CH	16 CH	60 CH	63 CH	69 CH	72 CH	120 CH		
									98	000 - 255	<b>Red13 Fine</b>
					50	50	50	50	99	000 - 255	<b>Green13, 0% to 100%</b>
									100	000 - 255	<b>Green13 Fine</b>
					51	51	51	51	101	000 - 255	<b>Blue13, 0% to 100%</b>
									102	000 - 255	<b>Blue13 Fine</b>
					52	52	52	52	103	000 - 255	<b>Lime13, 0% to 100%</b>
									104	000 - 255	<b>Lime13 Fine</b>
					53	53	53	53	105	000 - 255	<b>Red14, 0% to 100%</b>
									106	000 - 255	<b>Red14 Fine</b>
					54	54	54	54	107	000 - 255	<b>Green14, 0% to 100%</b>
									108	000 - 255	<b>Green14 Fine</b>
					55	55	55	55	109	000 - 255	<b>Blue14, 0% to 100%</b>
									110	000 - 255	<b>Blue14 Fine</b>
					56	56	56	56	111	000 - 255	<b>Lime14, 0% to 100%</b>
									112	000 - 255	<b>Lime14 Fine</b>
					57	57	57	57	113	000 - 255	<b>Red15, 0% to 100%</b>
									114	000 - 255	<b>Red15 Fine</b>
					58	58	58	58	115	000 - 255	<b>Green15, 0% to 100%</b>
									116	000 - 255	<b>Green15 Fine</b>
					59	59	59	59	117	000 - 255	<b>Blue15, 0% to 100%</b>
									118	000 - 255	<b>Blue15 Fine</b>
					60	60	60	60	119	000 - 255	<b>Lime15, 0% to 100%</b>
									120	000 - 255	<b>Lime15 Fine</b>
			5	5			61	61		000 - 255	<b>Color Macros</b> , please refer to the <b>Color Macros Chart</b> section of this manual
			6	6			62	62		000 - 255	<b>Color Temperature, 2700K - 7000K Linear</b>
											<b>Color Temperature Macros</b>
										000	Off
										001 - 042	2700K
										043 - 085	3200K
										086 - 128	4000K
										129 - 171	5600K
										172 - 214	6500K
										215 - 255	7000K

CONTINUED ON NEXT PAGE

# DMX TRAITS

CHANNEL										DMX VALUES	FUNCTION
4 CH	7 CH	8 CH	13 CH	16 CH	60 CH	63 CH	69 CH	72 CH	120 CH		
	5		8	8		61	64	64			<b>Shutter, Strobe</b>
										000 - 031	LEDs Off
										032 - 063	LEDs On
										064 - 095	Strobe effect, slow to fast
										096 - 127	LEDs On
										128 - 159	Pulse effect in sequences
										160 - 191	LEDs On
										192 - 223	Random strobe effect, slow to fast
										224 - 255	LEDs On
	6		9	9		62	65	65		000 - 255	<b>Dimmer Intensity</b> , 0% to 100%
	7		10	10		63	66	66		000 - 255	<b>Dimmer Fine</b>
											<b>Auto Programs</b>
										000 - 010	Off
										011 - 026	Auto Program 1
										027 - 043	Auto Program 2
										044 - 060	Auto Program 3
										061 - 076	Auto Program 4
										077 - 093	Auto Program 5
										094 - 110	Auto Program 6
				11					67	111 - 126	Auto Program 7
										127 - 143	Auto Program 8
										144 - 160	Auto Program 9
										161 - 176	Auto Program 10
										177 - 193	Auto Program 11
										194 - 210	Auto Program 12
										211 - 226	Auto Program 13
										227 - 241	Auto Program 14
										242-255	Auto Program 15
				12					68	000 - 255	<b>Auto Programs Speed</b> , slow to fast
				13					69	000 - 255	<b>Auto Programs Fade</b> , least to most

CONTINUED ON NEXT PAGE

# DMX TRAITS

CHANNEL										DMX VALUES	FUNCTION		
4 CH	7 CH	8 CH	13 CH	16 CH	60 CH	63 CH	69 CH	72 CH	120 CH				
												<b><i>Dim Mode</i></b>	
												000 - 020	Default to unit setting
												021 - 040	Standard
												041 - 060	Stage
												061 - 080	TV
												081 - 100	Architectural
												101 - 120	Theatre
												121 - 140	Stage 2
													<b><i>Dim Speed</i></b>
												141	0.1s
												142	0.2s
												143	0.3s
												144	0.4s
												145	0.5s
			11	14								146	0.6s
												147	0.7s
												148	0.8s
												149	0.9s
												150	1.0s
												151	1.5s
												152	2.0s
												153	3.0s
												154	4.0s
												155	5.0s
												156	6.0s
												157	7.0s
												158	8.0s
												159	9.0s
												160	10.0s
												161 - 255	Default to unit setting

CONTINUED ON NEXT PAGE

# DMX TRAITS

CHANNEL										DMX VALUES	FUNCTION
4 CH	7 CH	8 CH	13 CH	16 CH	60 CH	63 CH	69 CH	72 CH	120 CH		
			12	15			68	71			<b><i>Dim Curves</i></b>
											000 - 020 Linear
											021 - 040 Square
											041 - 060 Inv. Squa.
											061 - 080 S. Curve
											081 - 255 No function
			13	16			69	72			<b><i>Refresh Rates</i></b>
											000 - 015 Default to unit setting
											016 - 030 900 Hz
											031 - 045 1000 Hz
											046 - 060 1100 Hz
											061 - 075 1200 Hz
											076 - 090 1300 Hz
											091 - 105 1400 Hz
											106 - 120 1500 Hz
											121 - 135 2500 Hz
											136 - 150 4000 Hz
											151 - 165 5000 Hz
											166 - 180 10000 Hz
											181 - 195 15000 Hz
											196 - 210 20000 Hz
											211 - 225 25000 Hz
											226 - 255 No function

# PIXEL ZONES

## PIXEL FLIP OFF

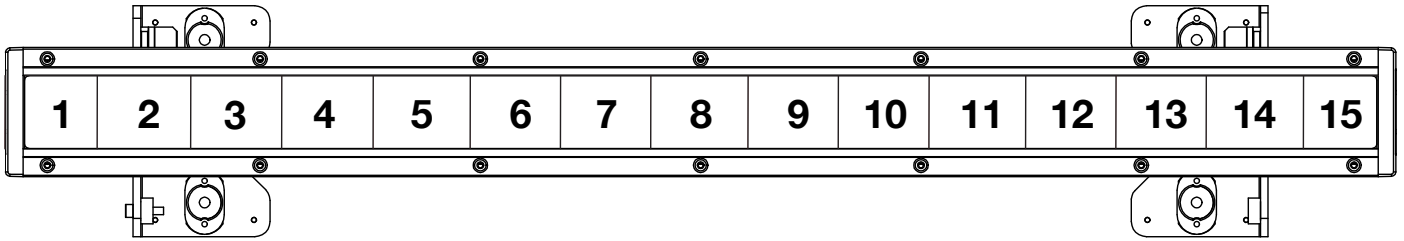

## PIXEL FLIP ON

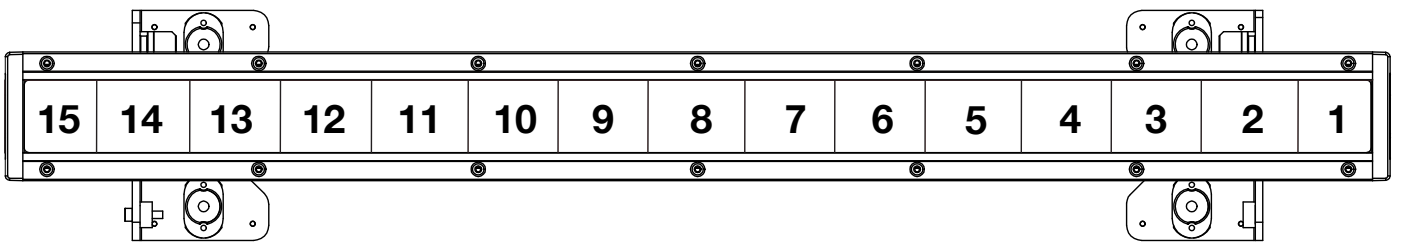

# COLOR MACRO CHART

Color	DMX Value	RGBW COLOR INTENSITY				Color	DMX Value	RGBW COLOR INTENSITY			
		RED	GREEN	BLUE	W/A			RED	GREEN	BLUE	WHITE
Off	0	0	0	0	0	Color Macro 33	129-132	255	206	143	0
Color Macro 1	1-4	80	255	234	80	Color Macro 34	133-136	254	177	153	0
Color Macro 2	5-8	80	255	164	80	Color Macro 35	137-140	254	192	138	0
Color Macro 3	9-12	77	255	112	77	Color Macro 36	141-144	254	165	98	0
Color Macro 4	13-16	117	255	83	83	Color Macro 37	145-148	254	121	0	0
Color Macro 5	17-20	160	255	77	77	Color Macro 38	149-152	176	17	0	0
Color Macro 6	21-24	223	255	83	83	Color Macro 39	153-156	96	0	11	0
Color Macro 7	25-28	255	243	77	77	Color Macro 40	157-160	234	139	171	0
Color Macro 8	29-32	255	200	74	74	Color Macro 41	161-164	224	5	97	0
Color Macro 9	33-36	255	166	77	77	Color Macro 42	165-168	175	77	173	0
Color Macro 10	37-40	255	125	74	74	Color Macro 43	169-172	119	130	199	0
Color Macro 11	41-44	255	97	77	71	Color Macro 44	173-176	147	164	212	0
Color Macro 12	45-48	255	74	77	71	Color Macro 45	177-180	88	2	163	0
Color Macro 13	49-52	255	83	134	83	Color Macro 46	181-184	0	38	86	0
Color Macro 14	53-56	255	93	182	93	Color Macro 47	185-188	0	142	208	0
Color Macro 15	57-60	255	96	236	96	Color Macro 48	189-192	52	148	209	0
Color Macro 16	61-64	238	93	255	93	Color Macro 49	193-196	1	134	204	0
Color Macro 17	65-68	163	87	255	87	Color Macro 50	197-200	0	145	212	0
Color Macro 18	69-72	150	90	255	90	Color Macro 51	201-204	0	121	192	0
Color Macro 19	73-76	100	77	255	77	Color Macro 52	205-208	0	129	184	0
Color Macro 20	77-80	77	100	255	77	Color Macro 53	209-212	0	83	115	0
Color Macro 21	81-84	67	148	255	67	Color Macro 54	213-216	0	97	166	0
Color Macro 22	85-88	77	195	255	77	Color Macro 55	217-220	1	100	167	0
Color Macro 23	89-92	77	234	255	77	Color Macro 56	221-224	0	40	86	0
Color Macro 24	93-96	158	255	144	144	Color Macro 57	225-228	209	219	182	0
Color Macro 25	97-100	255	251	153	153	Color Macro 58	229-232	42	165	85	0
Color Macro 26	101-104	255	175	147	147	Color Macro 59	233-236	0	46	35	0
Color Macro 27	105-108	255	138	186	138	Color Macro 60	237-240	8	107	222	0
Color Macro 28	109-112	255	147	251	147	Color Macro 61	241-244	255	0	0	0
Color Macro 29	113-116	151	135	255	138	Color Macro 62	245-248	0	255	0	0
Color Macro 30	117-120	99	0	255	100	Color Macro 63	249-252	0	0	255	0
Color Macro 31	121-124	138	169	255	138	Color Macro 64	253-255	0	0	0	255
Color Macro 32	128-128	255	255	255	255						

# DIMMER MODES

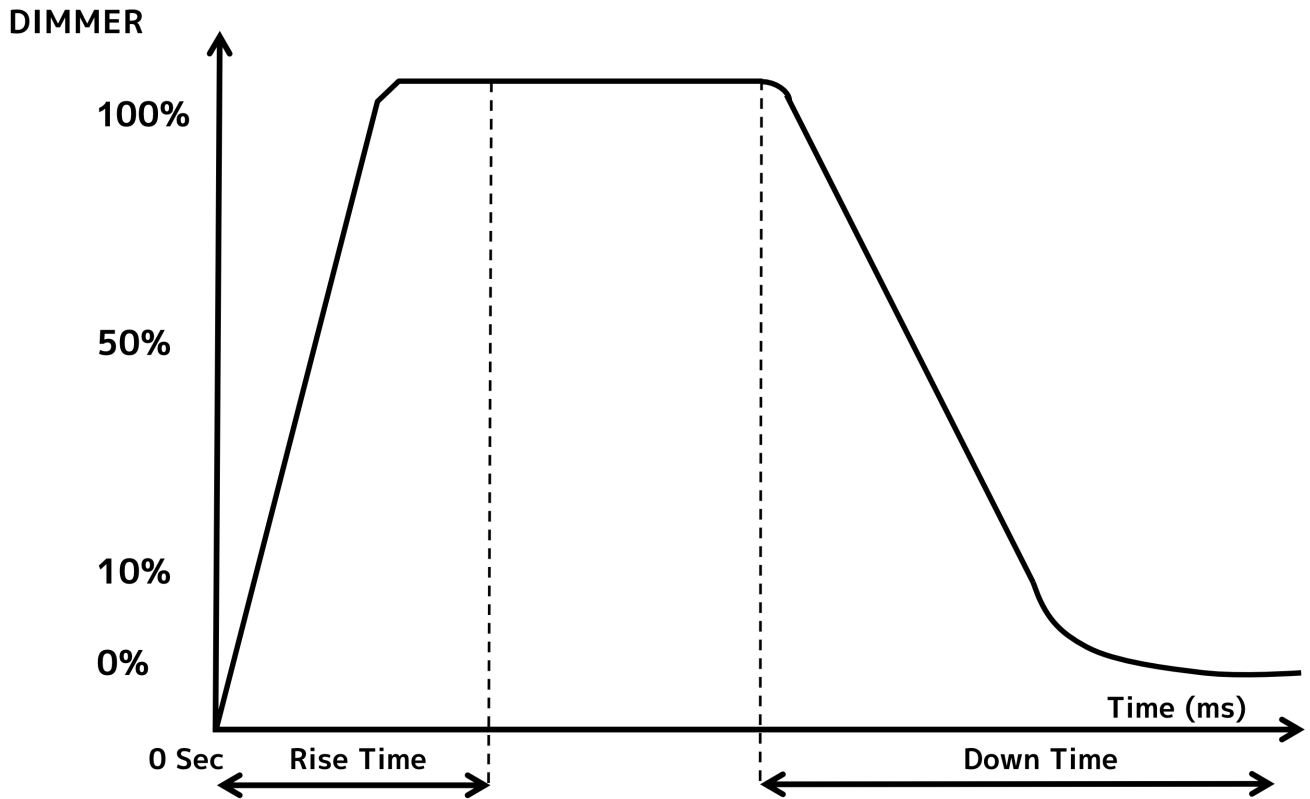

Dimming Curve Ramp Effect	0 sec Fade Time		1 sec Fade Time	
	Rise Time (ms)	Down Time (ms)	Rise Time (ms)	Down Time (ms)
Standard (default)	0	0	0	0
Stage	780	1100	1540	1660
TV	1180	1520	1860	1940
Architectural	1380	1730	2040	2120
Theatre	1580	1940	2230	2280
Stage 2	0	1100	0	1660

# DAISY CHAIN POWER LINKING

These units have the capability to be daisy chained together via the power in/out ports.

**The maximum number of units that can be linked together in this manner is as follows:**

- 2 units maximum when running on 110V power.
- 5 units maximum when running on 240V power.

**DO NOT EXCEED THE NUMBER OF UNITS LISTED ABOVE.**

**DO NOT MIX MAKE AND MODEL TYPES WHEN DAISY CHAINING!** All units that are connected in this manner must be of the same make and model type.

## CLEANING AND MAINTENANCE

**DISCONNECT POWER BEFORE PERFORMING ANY MAINTENANCE!**

### CLEANING

Frequent cleaning is recommended to ensure proper function, optimized light output, and an extended life. The frequency of cleaning depends on the environment in which the fixture operates: damp, smoky, or particularly dirty environments can cause greater accumulation of dirt on the fixture's optics. Clean the external lens surface periodically with a soft cloth to avoid dirt/debris accumulation.

**NEVER** use alcohol, solvents, or ammonia-based cleaners.

### MAINTENANCE

Regular inspections are recommended to ensure proper function and extended life. There are no user serviceable parts inside this fixture. Please refer all other service issues to an authorized ADJ service technician. Should you need any spare parts, please order genuine parts from your local ADJ dealer.

Please refer to the following points during routine inspections:

- A detailed electrical check by an approved electrical engineer every three months, to make sure the circuit contacts are in good condition and prevent overheating.
- Be sure all screws and fasteners are securely tightened at all times. Loose screws may fall out during normal operation, resulting in damage or injury as larger parts could fall.
- Check for any deformations on the housing, color lenses, rigging hardware, and rigging points (ceiling, suspension, trussing). Deformations in the housing could allow for dust or liquids to enter into the fixture. Damaged rigging points or unsecured rigging could cause fixture to fall and seriously injure a person(s).
- Electric power supply cables must not show any damage, material fatigue, or sediments.

**NEVER** remove the ground prong from the power cable.

# SPECIFICATIONS

## SOURCE:

- 15 x 20-Watt Quad RGBL LEDs (4-IN-1: Red, Green, Blue & Lime)

## PHOTMETRIC DATA:

- Beam angle: 11° (25° with diffusion filter attached)
- CRI: 89.3
- CRI R9: 69
- Lumens: 5982
- Linear Color Temperature Control (2700K to 7000K)
- Preset Color Temperatures (2700K, 3200K, 4000K, 5600K, 6500K and 7000K)

## EFFECTS:

- Individual Pixel Controllable
- 16-Bit Fine Color Control (Red, Green, Blue & Lime)
- 64 built-in Color Macros

## CONTROL / CONNECTIONS:

- 4-button, DMX digital display on rear panel
- 5 Operational modes: Static Color Mode, RGBL Dimmer Mode, Program Mode, Sound Active Mode and DMX Controlled
- Supports RDM (Remote Device Management)
- With Wired Digital Communication Network
- 6 selectable Dimming Modes (Standard, Stage, TV, Architectural, Theatre & Stage 2)
- 4 selectable Dim Curves (Linear, Square Inv. Squa, S-Curve)
- Adjustable Refresh Rate (14 presets from 900 – 25,000Hz)
- Flicker Free operation (No flickering on camera)
- LED pulse and strobe effect
- Electronic Dimming: 0 - 100%
- 10 DMX Modes: 4, 7, 8, 13, 16, 60, 63, 69, 72 & 120 channel
- Adjustable fan modes
- WiFLY EXR Wireless DMX built-in (2500 ft. / 700M line of sight)

## CONSTRUCTION:

- IP65 Rated: Ingress Protection against liquid, snow, dust and sand
- All metal construction
- IP Rated rubber covers protect In/Out Locking Power connectors and IP rated 5-pin sockets
- Locking, outdoor IN/Out Power connectors
- Data linkable via 5-pin DMX connections

## ELECTRICAL / THERMAL:

- Multi-voltage operation: AC 100-240V, 47/63Hz
- Daisy chain: 5 @ 120V, 10 @ 220V
- Max power: 198W

## DIMENSIONS / WEIGHT:

- Dimensions (LxWxH) 5.99" x 36.0" x 8.33" / 152 x 915.0 x 211.55mm
- Weight: 19.5 lbs. / 8.85 kg.

## APPROVALS / RATINGS:

- cETLus Pending
- IP65

## INCLUDED ACCESSORIES:

- Glare Shield
- 25-Degree Frost Filter
- 2x Omega Brackets
- Locking Outdoor Power Cord

## OPTIONAL ACCESSORIES:

- ELB15L20: 20° frost filter for Encore LB15IP
- ELB15L60: 60° frost filter for Encore LB15IP
- ELB15L100: 100° frost filter for Encore LB15IP

\*Specifications are subject to change without notice.

# DIMENSIONS

## WITH GLARE SHIELD INSTALLED

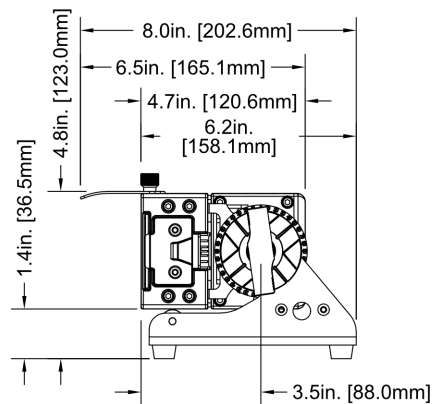
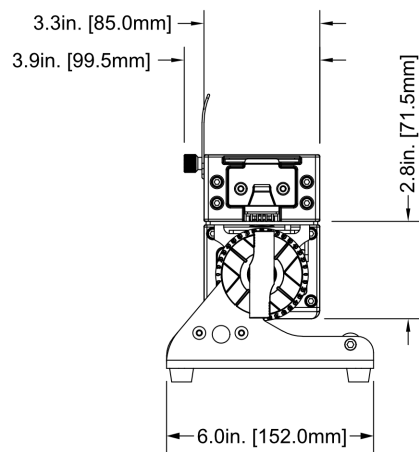
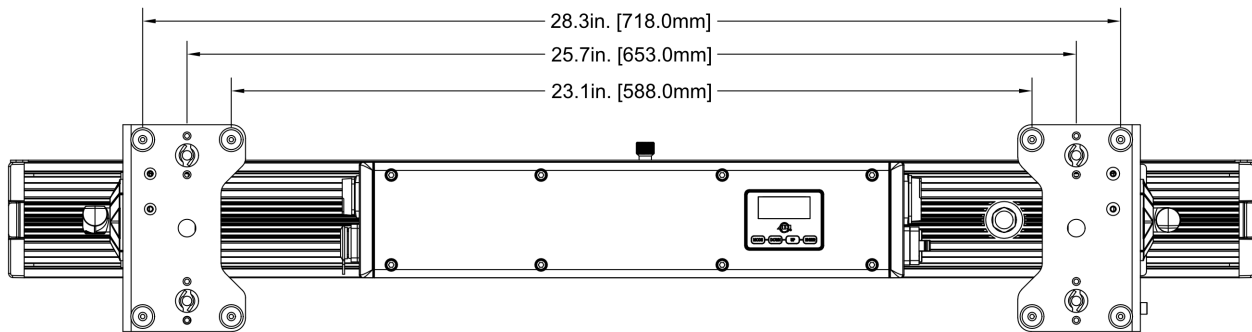
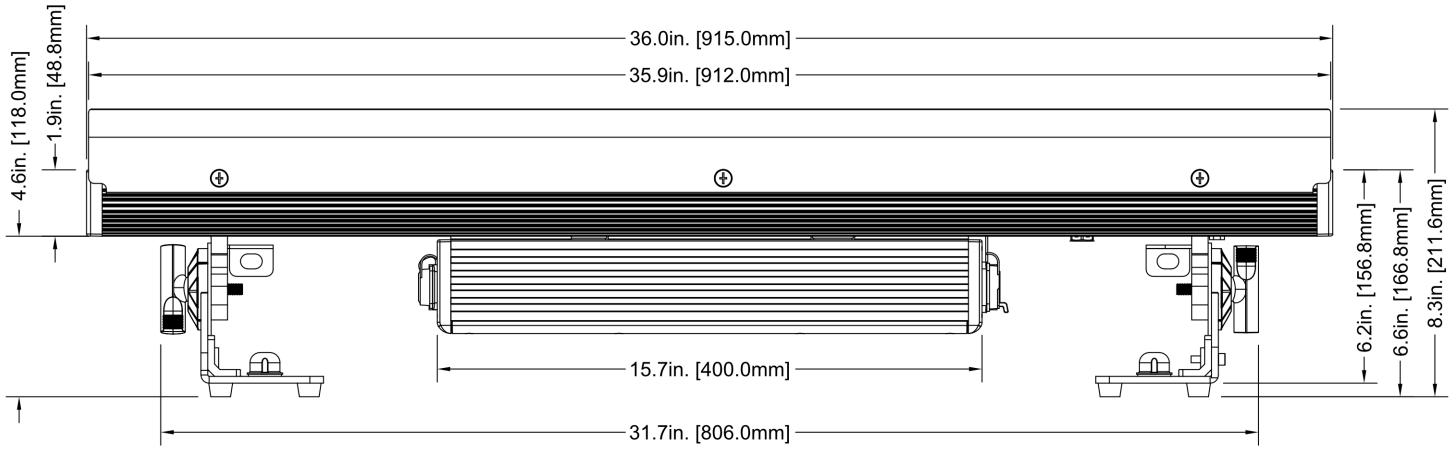

# DIMENSIONS

## WITHOUT GLARE SHIELD

