

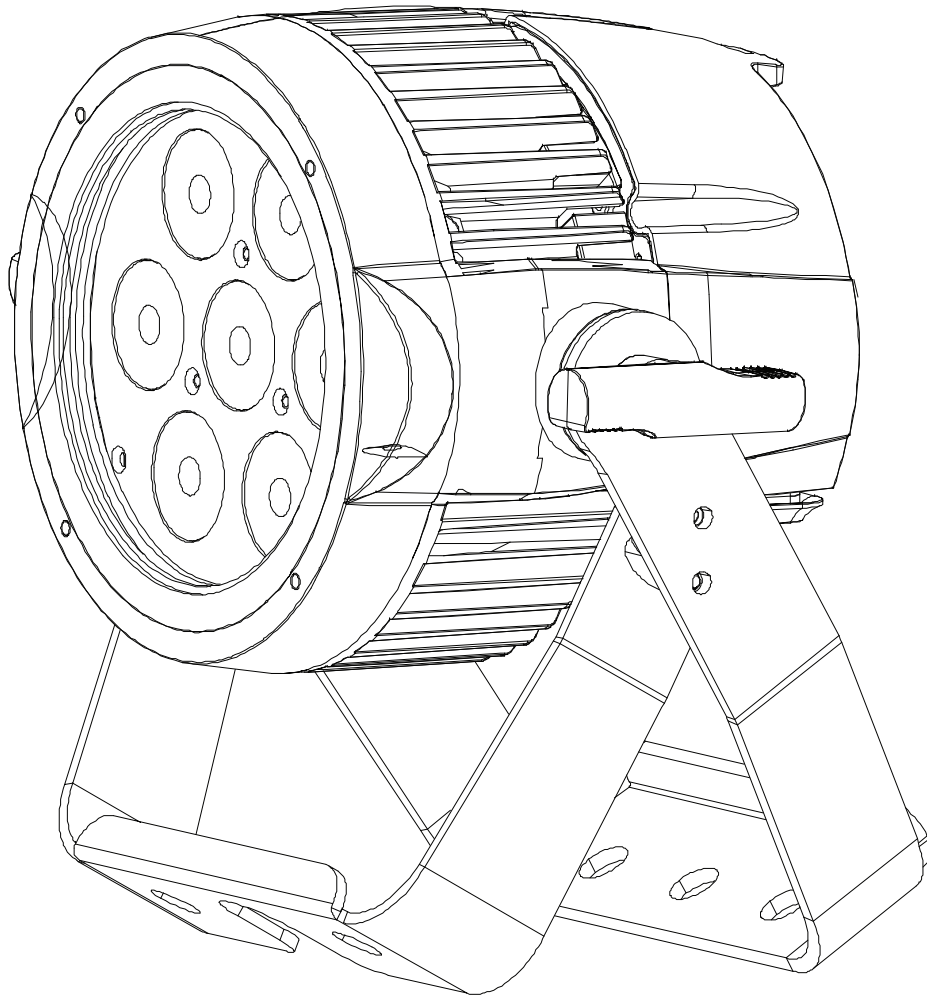

7P HEX IP



User Instructions

©2023 ADJ Products, LLC all rights reserved. Information, specifications, diagrams, images, and instructions herein are subject to change without notice. ADJ Products, LLC logo and identifying product names and numbers herein are trademarks of ADJ Products, LLC. Copyright protection claimed includes all forms and matters of copyrightable materials and information now allowed by statutory or judicial law or hereinafter granted. Product names used in this document may be trademarks or registered trademarks of their respective companies and are hereby acknowledged. All non-ADJ Products, LLC brands and product names are trademarks or registered trademarks of their respective companies.

ADJ Products, LLC and all affiliated companies hereby disclaim any and all liabilities for property, equipment, building, and electrical damages, injuries to any persons, and direct or indirect economic loss associated with the use or reliance of any information contained within this document, and/or as a result of the improper, unsafe, insufficient and negligent assembly, installation, rigging, and operation of this product.

FCC STATEMENT

This device complies with Part 15 of the FCC Rules. Operation is subject to the following two conditions: (1) this device may not cause harmful interference, and (2) this device must accept any interference received, including interference that may cause undesired operation.

FCC RADIO FREQUENCY INTERFERENCE WARNINGS & INSTRUCTIONS

This product has been tested and found to comply with the limits as per Part 15 of the FCC Rules. These limits are designed to provide reasonable protection against harmful interference in a residential installation. This device uses and can radiate radio frequency energy and, if not installed and used in accordance with the included instructions, may cause harmful interference to radio communications. However, there is no guarantee that interference will not occur in a particular installation. If this device does cause harmful interference to radio or television reception, which can be determined by turning the device off and on, the user is encouraged to try to correct the interference by one or more of the following methods:

- **Reorient or relocate the device.**
- **Increase the separation between the device and the receiver.**
- **Connect the device to an electrical outlet on a circuit different from which the radio receiver is connected.**
- **Consult the dealer or an experienced radio/TV technician for help.**

DOCUMENT VERSION

Due to additional product features and/or enhancements, an updated version of this document may be available online. Please check www.adj.com for the latest revision/update of this manual before beginning installation and/or programming.

Date	Document Version	Software Version ≥	DMX Channel Modes	Notes
05/30/18	1	1.04	6/7/8/13	Initial Version
06/13/18	1.2	1.05	N/C	Updated Color Macros
08/28/19	1.3	N/C	N/C	ETL Approval
10/11/19	1.4	1.07	N/C	Gamma Removed, Dim Curves Added
09/03/20	1.5	1.08	N/C	Updated primary/secondary
02/19/21	1.6	1.09	N/C	Updated system menu
11/29/23	1.7	N/C	N/C	Updated Specifications

Europe Energy Saving Notice

Energy Saving Matters (EuP 2009/125/EC)

Saving electric energy is a key to help protecting the environment. Please turn off all electrical products when they are not in use. To avoid power consumption in idle mode, disconnect all electrical equipment from power when not in use. Thank you!

TABLE OF CONTENTS

Introduction	3
Features Warranty Registration Installation	4
Safety Precautions	5
IP Notice	6
Layout	7
DMX Set Up	8
DMX Addressing	10
DMX Channel Modes	11
Color Macro Chart	13
System Menu	15
Operating Instructions	18
Primary-Secondary Configuration	21
Dimmer Mode Chart Dimmer Curve Chart	22
Dimensional Drawings	23
Power Linking Trouble Shooting Cleaning	24
Limited Warranty (USA Only)	25
Technical Specifications	26

INTRODUCTION

Unpacking: Thank you for purchasing the 7P Hex IP by ADJ Products, LLC. Every 7P Hex IP has been thoroughly tested and has been shipped in perfect operating condition. Carefully check the shipping carton for damage that may have occurred during shipping. If the carton appears to be damaged, carefully inspect your fixture for any damage and be sure all accessories necessary to operate the unit has arrived intact. In the case damage has been found or parts are missing, please contact our toll free customer support number for further instructions. Do not return this unit to your dealer without first contacting customer support.

Introduction: The 7P Hex IP is a DMX intelligent, IP rated LED par fixture. This fixture can be used in a stand alone mode or connected in a Primary/Secondary configuration. This par has five operating modes: RGBWA + UV dimmer mode, Static Color mode, Auto Run mode, Color Macro mode, and DMX control. ***This product is intended to be used by professionally trained personnel only and is not suitable for private use.***

These instructions contain important safety information regarding the use and maintenance of this unit. Please keep this manual with the unit, for future reference.

Customer Support: Contact ADJ Service for any product related service and support needs. Also visit forums.adj.com with questions, comments or suggestions.

Parts: To purchase parts online visit:

<http://parts.adj.com> (US)

<http://www.adjparts.eu> (EU)

ADJ SERVICE USA - Monday - Friday 8:00am to 4:30pm PST

Voice: 800-322-6337 | Fax: 323-582-2941 | support@adj.com

ADJ SERVICE EUROPE - Monday - Friday 08:30 to 17:00 CET

Voice: +31 45 546 85 60 | Fax: +31 45 546 85 96 | support@adj.eu

ADJ PRODUCTS LLC USA

6122 S. Eastern Ave. Los Angeles, CA. 90040

323-582-2650 | Fax 323-532-2941 | www.adj.com | info@adj.com

ADJ SUPPLY Europe B.V

Junostraat 2 6468 EW Kerkrade, The Netherlands

+31 (0)45 546 85 00 | Fax +31 45 546 85 99

www.adj.eu | info@adj.eu

ADJ PRODUCTS GROUP Mexico

AV Santa Ana 30 Parque Industrial Lerma, Lerma, Mexico 52000

+52 (728) 282-7070

Caution! There are no user serviceable parts inside this unit. Do not attempt any repairs yourself, doing so will void your manufactures warranty. In the unlikely event your unit may require service please contact ADJ Products, LLC.

PLEASE recycle the shipping carton when ever possible.

FEATURES

- Multi-Colors
- Five Operating Modes
- Electronic Dimming 0-100%
- DMX-512 protocol
- IP65 Locking 3-Pin XLR Connections In/Out
- Four DMX Modes: 6 Channel Mode, 7 Channel Mode, 8 Channel Mode, and 13 Channel Mode.
- Multiple Unit Power Linking (See page 24)

Included:

1 x IP65 Locking Power Cable

WARRANTY REGISTRATION

The 7P Hex IP carries a 2 year limited warranty. Please fill out the enclosed warranty card to validate your purchase. All returned service items whether under warranty or not, must be freight pre-paid and accompany a return authorization (R.A.) number. The R.A. number must be clearly written on the outside of the return package. A brief description of the problem as well as the R.A. number must also be written down on a piece of paper included in the shipping carton. If the unit is under warranty, you must provide a copy of your proof of purchase invoice. You may obtain a R.A. number by contacting our customer support team on our customer support number. All packages returned to the service department not displaying a R.A. number on the outside of the package will be returned to the shipper.

INSTALLATION

The unit should be mounted using a mounting clamp (not provided), affixing it to the mounting bracket that is provided with the unit. Always ensure that the unit is firmly fixed to avoid vibration and slipping while operating. Always ensure that the structure to which you are attaching the unit is secure and is able to support a weight of 10 times the unit's weight. Also, always use a safety cable that can hold 12 times the weight of the unit when installing the fixture.

The equipment must be installed by a professional, and it must be installed in a place where it is out of the reach of people's grasp.

Ensure ALL connections and end caps are properly sealed with a non-conductive dielectric grease (available at most electrical suppliers) to prevent water ingress/condensation and/or corrosion.

SAFETY PRECAUTIONS

- Do not attempt to operate this unit if the power cord has been frayed or broken. Do not attempt to remove or break off the ground prong from the electrical cord. This prong is used to reduce the risk of electrical shock and fire in case of an internal short.
- Disconnect from main power before making any type of connection.
- Do not remove the cover under any conditions. There are no user serviceable parts inside.
- Never operate this unit when it's cover is removed.
- Never plug this unit in to a dimmer pack
- Always be sure to mount this unit in an area that will allow proper ventilation. Allow about 6" (15cm) between this device and a wall.
- Do not attempt to operate this unit, if it becomes damaged.
- During long periods of non-use, disconnect the unit's main power.
- Always mount this unit in safe and stable matter.
- Power-supply cords should be routed so that they are not likely to be walked on or pinched by items placed upon or against them, paying particular attention to the point they exit from the unit.
- Cleaning -The fixture should be cleaned only as recommended by the manufacturer. See page 24 for cleaning details.
- Heat -The appliance should be situated away from heat sources such as radiators, heat registers, stoves, or other appliances (including amplifiers) that produce heat.
- The fixture should be serviced by qualified service personnel when:
 - A. The power-supply cord or the plug has been damaged.
 - B. Objects have fallen, or liquid has been spilled into the fixture.
 - C. The fixture does not appear to operate normally or exhibits a marked change in performance.
 - D. The fixture has fallen and/or subjected to extreme handling.

SAFETY PRECAUTIONS



RISK GROUP 3 - RISK OF EXPOSURE TO ULTRAVIOLET (UV) RADIATION!

FIXTURE EMITS HIGH INTENSITY ULTRAVIOLET (UV) LIGHT FROM THE UV LED.

WEAR PROPER EYE AND SKIN PROTECTION.

AVOID PROLONGED PERIODS OF EXPOSURE TO THE UV LED.

AVOID WEARING WHITE COLOR CLOTHING AND/OR USING (UV) PAINTS ON SKIN.

AVOID DIRECT EYE AND/OR SKIN EXPOSURE AT DISTANCES SHORTER THAN 11 feet (3.3m).

DO NOT OPERATE FIXTURE WITH DAMAGED OR MISSING EXTERNAL COVER.

DO NOT LOOK DIRECTLY INTO THE (UV) LIGHT AND/OR VIEW (UV) LIGHT DIRECTLY WITH OPTICAL INSTRUMENTS THAT MAY CONCENTRATE THE LIGHT/RADIATION OUTPUT.

INDIVIDUALS SUFFERING FROM A RANGE OF EYE CONDITIONS, SUNLIGHT EXPOSURE DISORDERS, OR INDIVIDUALS USING PHOTSENSITIVE MEDICATION, MAY RECEIVE DISCOMFORT IF EXPOSED TO THE ULTRAVIOLET (UV) LIGHT EMITTED FROM THIS FIXTURE.

IP NOTICE

IP65 RATED

An IP rated lighting fixture is one, which is commonly installed in outdoor environments and has been designed with an enclosure that effectively water. The **International Protection (IP)** rating system is commonly expressed as "**IP**" (Ingress Protection) followed by two numbers (i.e. IP65) where the numbers define the degree of protection. The first digit (Foreign Bodies Protection) indicates the extent of protection against particles entering the fixture and the second digit (Water Protection) indicates the extent of protection against water entering the fixture. An IP65 rated lighting fixture is one, which has been designed and tested to protect against the ingress of dust (6) and low-pressure water jets from any direction (5).

MARINE/COASTAL ENVIRONMENT INSTALLATIONS!



Please note although this fixture is IP rated, the fixture is NOT suitable for marine and/or coastal environment installations. Installing this fixture in a marine and/or coastal environment may cause corrosion and/or excessive wear to the interior and/or exterior components of the fixture. Damages and/or performance issues resulting from installation in a marine and/or coastal environment will void the manufactures warranty and will NOT be subject to any warranty claims and/or repairs.

OPTIONAL CORROSION-RESISTANT COATING

Optional Corrosion-Resistant Coatings may be available for this fixture. Please consult your **ADJ Products, LLC** sales representative for details.

LAYOUT

LCD Screen
Mode Button
Up Button
Down Button
Enter Button

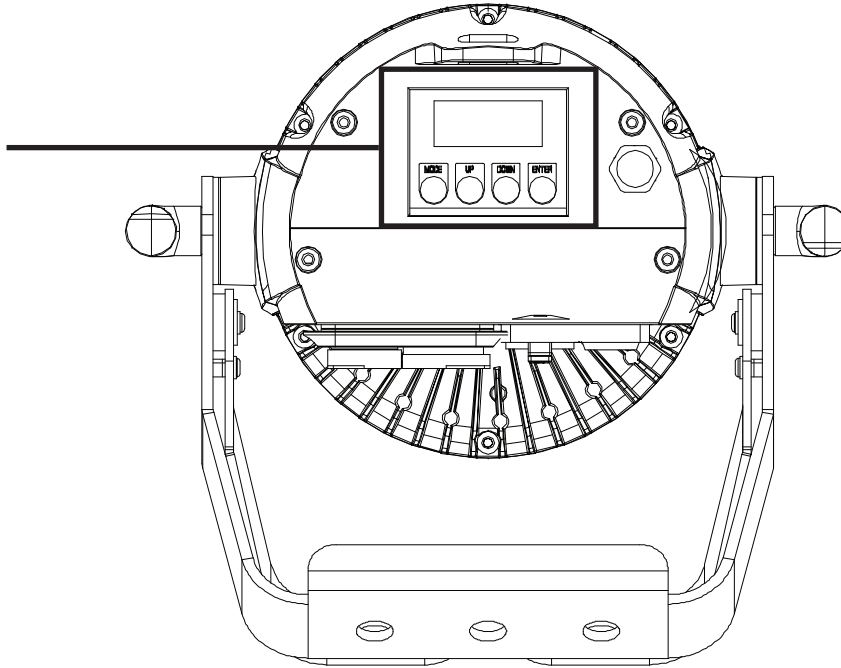

IP65 Locking Power
Connection In/Out
IP65 Locking 5-Pin
XLR Connector In/Out

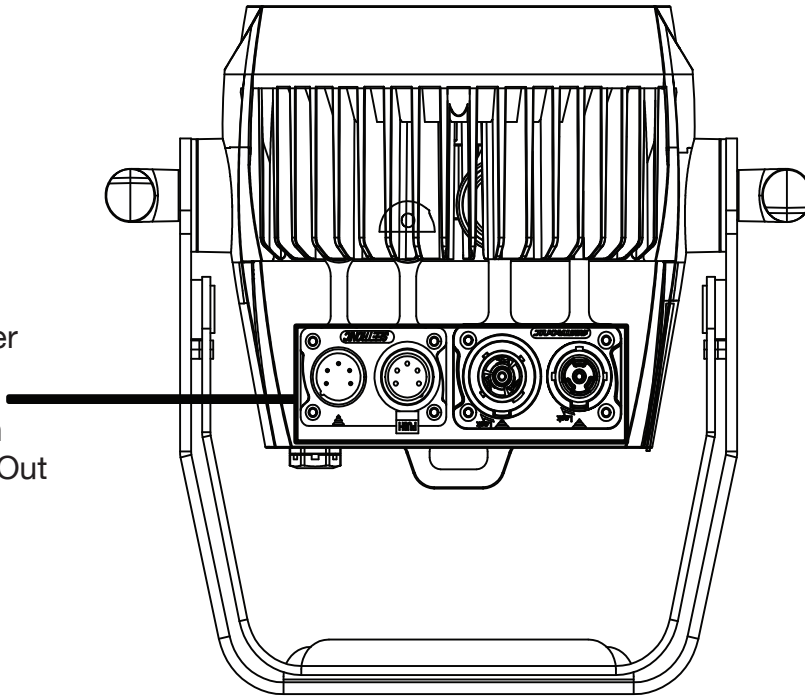

DMX SET UP

DMX-512: DMX is short for Digital Multiplex. This is a universal protocol used as a form of communication between intelligent fixtures and controllers. A DMX controller sends DMX data instructions from the controller to the fixture. DMX data is sent as serial data that travels from fixture to fixture via the DATA “IN” and DATA “OUT” XLR terminals located on all DMX fixtures (most controllers only have a DATA “OUT” terminal).

DMX Linking: DMX is a language allowing all makes and models of different manufactures to be linked together and operate from a single controller, as long as all fixtures and the controller are DMX compliant. To ensure proper DMX data transmission, when using several DMX fixtures try to use the shortest cable path possible. The order in which fixtures are connected in a DMX line does not influence the DMX addressing. For example; a fixture assigned a DMX address of 1 may be placed anywhere in a DMX line, at the beginning, at the end, or anywhere in the middle. When a fixture is assigned a DMX address of 1, the DMX controller knows to send DATA assigned to address 1 to that unit, no matter where it is located in the DMX chain.

Data Cable (DMX Cable) Requirements (For DMX Operation): The 7P Hex IP can be controlled via DMX-512 protocol. The 7P Hex IP has 4 DMX channel modes. The DMX address is set on the rear panel of the 7P Hex IP. Your unit requires a standard 5-pin XLR connector for data input and data output. We recommend Accu-Cable DMX cables. If you are making your own cables, be sure to use standard 110-120 Ohm shielded cable (This cable may be purchased at almost all pro lighting stores). Your cables should be made with a male and female XLR connector on either end of the cable. Also remember that DMX cable must be daisy chained and cannot be split.

DMX SET UP

Special Note: Line Termination. When longer runs of cable are used, you may need to use a terminator on the last unit to avoid erratic behavior. A terminator is a 110-120 ohm 1/4 watt resistor which is connected between pins 2 and 3 of a male XLR connector (DATA + and DATA -). This unit is inserted in the female XLR connector of the last unit in your daisy chain to terminate the line. Using a cable terminator (ADJ part number Z-DMX/T) will decrease the possibilities of erratic behavior.



Termination reduces signal errors and avoids signal transmission problems and interference. It is always advisable to connect a DMX terminal, (Resistance 120 Ohm 1/4 W) between PIN 2 (DMX-) and PIN 3 (DMX +) of the last fixture.

Figure 4

5-Pin XLR DMX Connectors. Some manufactures use 5-pin DMX-512 data cables for DATA transmission in place of 3-pin. 5-pin DMX fixtures may be implemented in a 3-pin DMX line. When inserting standard 5-pin data cables in to a 3-pin line a cable adaptor must be used, these adaptors are readily available at most electric stores. The chart below details a proper cable conversion.

3-Pin XLR to 5-Pin XLR Conversion		
Conductor	3-Pin XLR Female (Out)	5-Pin XLR Male (In)
Ground/Shield	Pin 1	Pin 1
Data Compliment (- signal)	Pin 2	Pin 2
Data True (+ signal)	Pin 3	Pin 3
Not Used		Do Not Use
Not Used		Do Not Use

DMX ADDRESSING

All fixtures should be given a DMX starting address when using a DMX controller, so the correct fixture responds to the correct control signal. This digital starting address is the channel number from which the fixture starts to “listen” to the digital control signal sent out from the DMX controller. The assignment of this starting DMX address is achieved by setting the correct DMX address on the digital control display on the fixture.

You can set the same starting address for all fixtures or a group of fixtures, or set different addresses for each individual fixture. Setting all fixtures to the same DMX address will cause all fixtures to react in the same way, in other words, changing the settings of one channel will affect all the fixtures simultaneously.

If you set each fixture to a different DMX address, each unit will start to “listen” to the channel number you have set, based on the quantity of DMX channels of each fixture. That means changing the settings of one channel will only affect the selected fixture.

In the case of the 7P Hex IP, when in 13 channel mode you should set the starting DMX address of the first unit to 1, the second unit to 14 (13 + 1), the third unit to 27 (14 + 13), and so on. (See chart below for more details.)

Channel Mode	Unit 1 Address	Unit 2 Address	Unit 3 Address	Unit 4 Address
6 channels	1	7	13	19
7 channels	1	8	15	22
8 channels	1	9	17	25
13 channels	1	14	27	40

DMX TRAITS & VALUES

6CH	7CH	8CH	13CH		
1	1	1	1	0-255	<u>Red</u> 0~100%
2	2	2	2	0-255	<u>Green</u> 0~100%
3	3	3	3	0-255	<u>Blue</u> 0~100%
4	4	4	4	0-255	<u>White</u> 0~100%
5	5	5	5	0-255	<u>Amber</u> 0~100%
6	6	6	6	0-255	<u>UV</u> 0~100%
	7	7	7	0-255	<u>Master Dimmer</u> 0 ~100%
		8	8	0 - 31 32 - 63 64 - 95 96 - 127 128 - 159 160 - 191 192 - 223 224 - 255	<u>Strobe</u> LED Off LED On Strobe Slow - Fast LED On Strobe Pulse Slow - Fast LED On Random Strobe LED On
			9	0 - 255	<u>Color Macro</u> See pages 13-14 for the Color Macro Chart
			10	0 - 19 20 - 39 40 - 59 60 - 79 80 - 99 100 - 119 120 - 139 140 - 159 160 - 179 180 - 199 200 - 219 220 - 239 240 - 255	<u>Auto Programs</u> No Function Program 1 Program 2 Program 3 Program 4 Program 5 Program 6 Program 7 Program 8 Program 9 Program 10 Program 11 Program 12
			11	0 - 255	<u>Auto Program Speed</u> From slow to fast
			12	0 - 255	<u>Auto Program Fade</u> From slow to fast
			13	0 - 20 21-40 41-60 61-80 81-100 101-255	<u>Dimmer Modes</u> Standard Stage TV Architectural Theatre Default to unit setting

COLOR MACRO CHART

Color No.	DMX VALUE	RGBWA+UV COLOR INTENSITY					
		RED	GREEN	BLUE	WHITE	AMBER	UV
OFF	0	0	0	0	0	0	0
Color1	1-4	80	255	234	80	0	0
Color2	5-8	80	255	164	80	0	0
Color3	9-12	77	255	112	77	0	0
Color4	13-16	117	255	83	83	0	0
Color5	17-20	160	255	77	77	0	0
Color6	21-24	223	255	83	83	0	0
Color7	25-28	255	243	77	77	0	0
Color8	29-32	255	200	74	74	0	0
Color9	33-36	255	166	77	77	0	0
Color10	37-40	255	125	74	74	0	0
Color11	41-44	255	97	77	74	0	0
Color12	45-48	255	71	77	71	0	0
Color13	49-52	255	83	134	83	0	0
Color14	53-56	255	93	182	93	0	0
Color15	57-60	255	96	236	96	0	0
Color16	61-64	238	93	255	93	0	0
Color17	65-68	196	87	255	87	0	0
Color18	69-72	150	90	255	90	0	0
Color19	73-76	100	77	255	77	0	0
Color20	77-80	77	100	255	77	0	0
Color21	81-84	67	148	255	67	0	0
Color22	85-88	77	195	255	77	0	0
Color23	89-92	77	234	255	77	0	0
Color24	93-96	158	255	144	144	0	0
Color25	97-100	255	251	153	153	0	0
Color26	101-104	255	175	147	147	0	0
Color27	105-108	255	138	186	138	0	0
Color28	109-112	255	147	251	147	0	0
Color29	113-116	151	138	255	138	0	0
Color30	117-120	100	138	255	138	0	0
Color31	121-124	138	169	255	138	0	0
Color32	125-128	255	255	255	255	0	0

COLOR MACRO CHART

Color No.	DMX VALUE	RGBWA+UV COLOR INTENSITY					
		RED	GREEN	BLUE	WHITE	AMBER	UV
Color33	129-132	255	206	143	0	0	0
Color34	133-136	254	177	153	0	0	0
Color35	137-140	254	192	138	0	0	0
Color36	141-144	254	165	98	0	0	0
Color37	145-148	254	121	0	0	0	0
Color38	149-152	176	17	0	0	0	0
Color39	153-156	96	0	11	0	0	0
Color40	157-160	234	139	171	0	0	0
Color41	161-164	224	5	97	0	0	0
Color42	165-168	175	77	173	0	0	0
Color43	169-172	119	130	199	0	0	0
Color44	173-176	147	164	212	0	0	0
Color45	177-180	88	2	163	0	0	0
Color46	181-184	0	38	86	0	0	0
Color47	185-188	0	142	208	0	0	0
Color48	189-192	52	148	209	0	0	0
Color49	193-196	0	46	35	0	0	0
Color50	197-200	8	107	222	0	0	0
Color51	201-204	107	156	231	0	0	0
Color52	205-208	165	198	247	0	0	0
Color53	209-212	0	83	115	0	0	0
Color54	213-216	0	97	166	0	0	0
Color55	217-220	1	100	167	0	0	0
Color56	221-224	0	40	86	0	0	0
Color57	225-228	209	219	182	0	0	0
Color58	229-232	42	165	85	0	0	0
Color59	233-236	255	0	0	0	0	0
Color60	237-240	0	255	0	0	0	0
Color61	241-244	0	0	255	0	0	0
Color62	245-248	0	0	0	255	0	0
Color63	249-252	0	0	0	0	255	0
Color64	253-255	0	0	0	0	0	255

SYSTEM MENU

Software Version
 ≤ V1.04

MENU	SUB MENU	OPTIONS/VALUES (DEFAULT SHADED)	DESCRIPTION	
Display Menu	Update Wait.. ADJ V1.04			
Menu Set ADDR	Set ADDR 001	001-506	DMX Addressing	
Menu User Mode	CH06	6/7/8/13	DMX Channel Modes	
Menu Function	DimCurve Standard	Standard/Stage/TV/Architec/Theatre	Dimmer Curve Setting	
	NODMX Hold	Hold/Blackout/Program	DMX Lost Setting	
	AUTO RUN FQN01	01~99	Auto Run Programs	
	1. STATC CL:R	R/G/B/RG/GB/RB/RGB/BLAC STR 000-255	Static Color Mode	
	Macros 00	00~64	Color Macro Mode	
	LCD.Set	Backlight Key Lock DisFlash	05~60m ON/ON1/OFF ON/OFF	LCD Display Settings
	DFSET OFF	ON/OFF	Default Reset	
	TEMP Fahren	Fahren Celsius	Temperature Display Setting	
	Settings WhiteBal	Red: 000~255 Green: 000~255 Blue : 000~255 White: 000~255 Amber: 000~255 UV : 000~255	White Balance Setting	
	Fre_hz 900	900/1000/1100/1200/1300/1400/1500/2500/4000/5000/10k/15k/20k/25k	Set LED Refresh Frequency Rate	
Gamma 2.0	2.0/2.2/2.4/2.8	Set Gamma Brightness		

SYSTEM MENU

Software Version
 ≥ V1.07

MENU	SUB MENU	OPTIONS/VALUES (DEFAULT SHADED)	DESCRIPTION	
Display Menu	Update Wait.. ADJ V1.07			
Menu Set ADDR	Set ADDR 001	001 -506	DMX Addressing	
Menu User Mode	CH06	6/7/8/13	DMX Channel Modes	
Menu Function	Dim Mode Standard	Standard /Stage/TV/Architec/Theatre	Dimmer Mode Setting	
	NODMX Hold	Hold /Blackout/Program	DMX Lost Setting	
	AUTO RUN FQN: 01	01 ~99	Auto Run Programs	
	1. STATC CL: R	R /G/B/RG/GB/RB/RGB/BLAC STR 000- 255	Static Color Mode	
	Macros 00	00 ~64	Color Macro Mode	
	LCD.Set	Backlight Key Lock DisFlash	05 ~60m ON/ON1/OFF ON/OFF	LCD Display Settings
	DFSET OFF	ON/ OFF	Default Reset	
	TEMP Fahren	Fahren Celsius	Temperature Display Setting	
	Settings WhiteBal	Red: 000~255 Green: 000~255 Blue : 000~255 White: 000~255 Ambei 000~255 UV : 000~255	White Balance Setting	
	Fre_hz 900	900 /1000/1100/1200/1300/1400/1500/2500/4000/5000/10k/15k/20k/25k	Set LED Refresh Frequency Rate	
DimCurve	Linear /Square/Inv. Squa/S-Curve	Set Dimming Curve		

SYSTEM MENU

Software Version
 ≤ V1.08

Menu Info	Info TimeInfo	TimeInfo Current TimeInfo TotalTim TimeInfo LastClea TimeInfo TimerPIN	Current Running Time (Hours) Total Time (Hours) Last Time The Running Time Was Cleared (Hours) Clear 0 Password: (Password=050) Total Time Clear 0: (Password=060)
	Info TempInfo	TempInfo XXX	Current Running Temperature
	Info Model Inf		Model Name
	Info Software	V1.03	Current Software Version
	Info ErrorInf	None	Error Information
Menu Secondary	Secondary		Secondary Setting
Menu Manual	ManCtrlDimmer 000~255 ManCtrlRed 000~255 ManCtrlGreen 000~255 ManCtrlBlue 000~255 ManCtrlWhite 000~255 ManCtrlAmber 000~255 ManCtrlPurple 000~255 ManCtrlStrobe 000~255		Manual Control

OPERATING INSTRUCTIONS

DMX Addressing:

Operating through a DMX controller gives the user the freedom to create their own programs tailored to their own individual needs. The 7P Hex IP has 4 DMX modes: 6 Channel mode, 7 Channel mode, 8 Channel mode, and a 12 Channel mode.

1. To run your fixture in DMX mode press the MODE button and press the UP or DOWN buttons until “**Menu Set Addr**” is displayed and press ENTER. The current DMX address will now be displayed. Use the UP or DOWN buttons to find your desired DMX address, and press ENTER .
2. Please see page 13 for DMX values and traits.

DMX Channel Mode - With this function, you can select your desired DMX channel mode.

1. Access the main menu, and press the UP or DOWN buttons so that “**Menu User Mode**” is highlighted, then press ENTER.
2. Press the UP or DOWN buttons to scroll through the 4 DMX channel modes. When you have found your desired DMX channel mode, press ENTER.
3. Press the MODE button to return to the main menu.

Dimmer Mode Setting:

1. Access the main menu, and press the UP or DOWN buttons so that “**Menu Function**” is highlighted, then press ENTER. Press the UP or DOWN buttons so that “**Dim Mode**” is highlighted.
2. There are 5 dimmer mode settings to choose from. Please see the Dimmer Mode Chart on page 22 to see the settings and their respective beginning and ending fade times.

DMX State:

This mode is used as a precaution mode, that in case the DMX signal is lost, the operating mode chosen in the setup is the running mode the fixture will go into when the DMX signal is lost. You can also set this as the operating mode you would like the unit to return to when power is applied.

1. Access the main menu, and press the UP or DOWN buttons so that “**Menu Function**” is highlighted, then press ENTER. Press the UP or DOWN buttons so that “**NODMX**” is highlighted.
2. Use the UP and DOWN buttons to scroll through the 3 DMX standing states.
 - “Hold” - If the DMX signal is lost or interrupted, the fixture will stay in the last DMX set up. If power is applied and this mode is set, the unit will automatically go into the last DMX set up.
 - “Blackout” - If the DMX signal is lost or interrupted, the unit will automatically go into stand by mode.
 - “Program” - If the DMX signal is lost or interrupted, the unit will automatically go into Auto Run mode.
3. Use the UP and DOWN buttons to find your desired DMX state and press ENTER to confirm and press MODE to exit.

Auto Run Mode:

1. Access the main menu, and press the UP or DOWN buttons so that “**Menu Function**” is highlighted, then press ENTER. Use the UP or DOWN buttons to highlight “**AUTO RUN FQN**” and press ENTER.
2. Use the UP or DOWN buttons to scroll through the 99 Auto Run programs. Press ENTER to confirm your selection.

OPERATING INSTRUCTIONS

Static Color Mode:

1. Access the main menu, and press the UP or DOWN buttons so that **“Menu Function”** is highlighted, then press ENTER. Use the UP or DOWN buttons to highlight **“1. STATC CL:X”** and press ENTER. “X” is the current color that is displayed.
2. Press ENTER to access 1 of 3 internal programs: 6 Color Change Mode, 30 Color Change Mode, or Color Fade Mode. Use the UP and DOWN buttons to scroll through the programs. Press ENTER to make your selection. After making your selection you are able to adjust running speed. Use the UP or DOWN buttons to adjust the running speed, and press ENTER.
3. You are now able to adjust the strobe rate using the UP or DOWN buttons. Press ENTER after you have made your desired adjustment.
4. If you would like to run a static color, press the UP or DOWN buttons until **“1. STATC CL”** is displayed again and press ENTER. Use the UP or DOWN buttons to scroll through the static colors.
5. Press ENTER again to enter the strobe function. Use the UP and DOWN buttons to adjust the strobe rate. Press ENTER after you have found your desired strobe rate.

Color Macro Mode:

1. Plug the fixture in and press the MODE button and press the UP or DOWN buttons until **“Menu Function”** is displayed, and press ENTER.
2. Press the UP or DOWN buttons until **“Macros”** is displayed and press ENTER.
3. There are 64 colors to choose from. Find your desired color using the UP and DOWN buttons.
4. Once you have found your desired color press ENTER.

LCD Display Settings:

1. Plug the fixture in and press the MODE button and press the UP or DOWN buttons until **“Menu Function”** is displayed, and press ENTER.
2. Press the UP or DOWN buttons until **“LCD.Set”** is displayed and press ENTER.
3. Use the UP and DOWN buttons to make adjustments, and press ENTER to move on to the next setting.
 - **“Backlight”** - This lets you set how long the backlight display will stay on.
 - **“Key Lock”** - This lets you control the key lock feature.
 - “ON”** - Press the MODE button for 10 seconds to unlock the keypad.
 - “OFF”** - The keypad is unlocked, simply press the MODE button to activate the keypad.
 - “ON1”** - This setting is used to prevent the accidental unlocking of the keypad. To unlock the keypad you will have to enter a passcode. Press the MODE button and the display will show **“LOCKED *****”**. To unlock the keypad press UP, DOWN, UP, DOWN, & ENTER in that order. Every press of these buttons will delete an asterisk.

Default Running Mode:

This is a default running mode. When this mode is activated all modes will return to their default settings.

1. Plug the fixture in and press the MODE button and press the UP or DOWN buttons until **“Menu Function”** is displayed, and press ENTER.
2. Press the UP or DOWN buttons until **“DFSET”** displayed, and press ENTER.
3. Use the UP or DOWN button to toggle between **“ON”** and **“OFF”**, press ENTER to make your selection. Press the MODE button to make no selection and exit.

OPERATING INSTRUCTIONS

Unit Temperature - With this function you can switch the temperature setting between celsius or fahrenheit.

1. Plug the fixture in and press the MODE button and press the UP or DOWN buttons until **“Menu Function”** is displayed, and press ENTER.
2. Press the UP or DOWN buttons until **“Temp”** is displayed and press ENTER.
3. Use the UP and DOWN buttons to switch between **“Fahren”** and **“Celsius”**.
4. Once you have found your desired setting press ENTER.

White Balance Settings - With this function you can adjust RGBWA & UV colors to balance the white color.

1. Plug the fixture in and press the MODE button and press the UP or DOWN buttons until **“Menu Function”** is displayed, and press ENTER.
2. Press the UP or DOWN buttons until **“Settings WhiteBal”** is displayed and press ENTER.
3. Use the UP and DOWN buttons to switch between the colors. When you have found the color you wish to adjust press ENTER. Use the UP or DOWN button to adjust the color values.
4. Once you have made your desired adjustment press ENTER.

Frequency Setting - With this function you can adjust the dimming frequency.

1. Plug the fixture in and press the MODE button and press the UP or DOWN buttons until **“Menu Function”** is displayed, and press ENTER.
2. Press the UP or DOWN buttons until **“Fre_hz”** is displayed and press ENTER.
3. Use the UP and DOWN buttons to scroll through different frequencies.
4. Once you have found your desired frequency press ENTER.

Gamma Brightness Setting - With this function you can adjust the gamma brightness.

Note: Removed from software version \leq V1.07.

1. Plug the fixture in and press the MODE button and press the UP or DOWN buttons until **“Menu Function”** is displayed, and press ENTER.
2. Press the UP or DOWN buttons until **“Gamma”** is displayed and press ENTER.
3. Use the UP and DOWN buttons to scroll through different settings.
4. Once you have found your desired setting press ENTER.

Dimmer Curve Setting:

Note: Added with software version \geq V1.07.

1. Access the main menu, and press the UP or DOWN buttons so that **“Menu Function”** is highlighted, then press ENTER. Press the UP or DOWN buttons so that **“Dim Mode”** is highlighted.
2. There are 4 dimmer curve settings to choose from. Please see the Dimmer Curve Chart on page 22.

OPERATING INSTRUCTIONS

Time Information:

1. Plug the fixture in and press the MODE button and press the UP or DOWN buttons until **“Menu Info”** is displayed, and press ENTER.
2. Press the UP or DOWN buttons to scroll through the different information menus. Press ENTER to access your desired menu.
3. Use the UP and DOWN buttons to scroll through time information menu.
 - **“TimeInfo Current”** - This will display the current running time of the fixture in hours.
 - **“TimeInfo TotalTim”** - This will display the total running time of the fixture in hours.
 - “TimeInfo LastClea”** - This will display the last time the running time was cleared.
 - “TimeInfo TimerPIN”** - This menu function will allow you to clear the running time.
 - “TemplInfo”** - This will display the current running temperature
 - “Model Inf”** - This will display the model name.
 - “ErrorInf”** - This will display any error information.

Secondary Setting - With this function you can set the unit as a “Secondary” in Primary-Secondary configuration.

1. Plug the fixture in and press the MODE button and press the UP or DOWN buttons until **“Secondary”** is displayed, and press ENTER.
2. The unit is now set as a “Secondary” in a Primary-Secondary configuration.

Manual Control - With this function you can manually adjust all colors to make your own desired color.

1. Plug the fixture in and press the MODE button and press the UP or DOWN buttons until **“Menu Manual”** is displayed, and press ENTER.
2. Press the UP or DOWN buttons to scroll through dimmer, the 6 colors, and strobe. Press ENTER and use the UP and DOWN buttons to make adjustments.
3. Once you have made your desired adjustments, press ENTER.

PRIMARY-SECONDARY CONFIGURATION

Primary-Secondary Configuration:

This function will allow you to link units together to run in a Primary-Secondary set-up. In a Primary-Secondary set up one unit will act as the controlling unit and the others will react to the controlling units built-in programs. Any unit can act as a Primary or as a Secondary however, only one unit can be programmed to act as the “Primary.”

Primary-Secondary Connections and Settings:

1. Daisy chain your units via the XLR connector on the rear of the unit. Use standard XLR data cables to link your units together. Remember that the Male XLR connector is the input and the Female XLR connector is the output. The first unit in the chain (*primary*) will use the female XLR connector only. The last unit in the chain will use the male XLR connector only.
2. Connect the first “Secondary” unit to the “Primary.”
3. Set the “Primary” unit to your desired mode of operation. On the “Secondary” unit’s press the MODE button and use the UP or DOWN buttons until **“Menu Secondary”** is displayed and press ENTER.

DIMMER MODE CHART

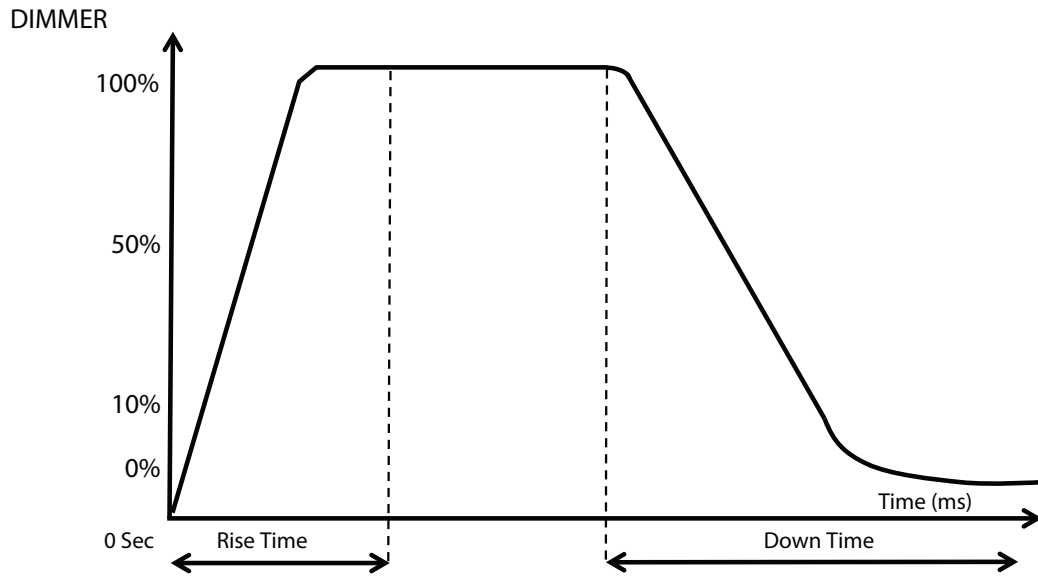

Dimming Mode Ramp Effect	0 sec Fade Time		1 sec Fade Time	
	Rise Time (ms)	Down Time (ms)	Rise Time (ms)	Down Time (ms)
Standard (default)	0	0	0	0
Stage	780	1100	1540	1660
TV	1180	1520	1860	1940
Architectural	1380	1730	2040	2120
Theatre	1580	1940	2230	2280

DIMMER CURVE CHART

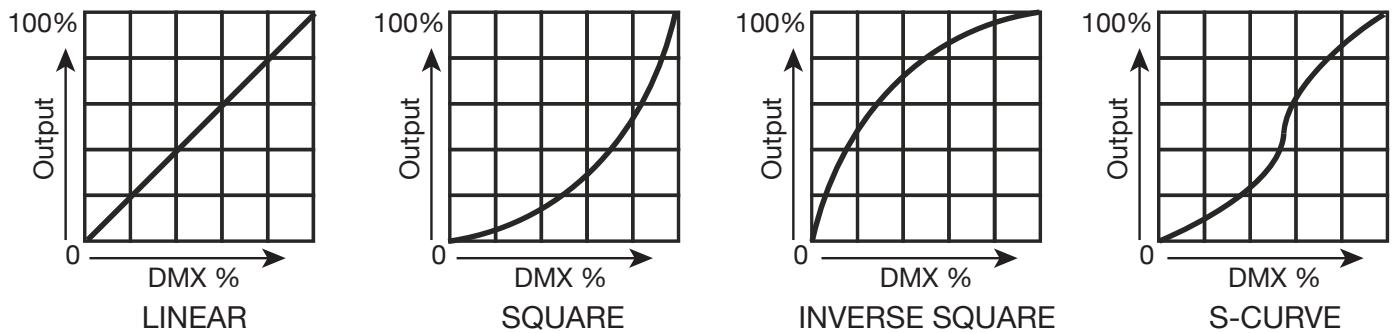

DIMENSIONAL DRAWING

***NOT TO SCALE**

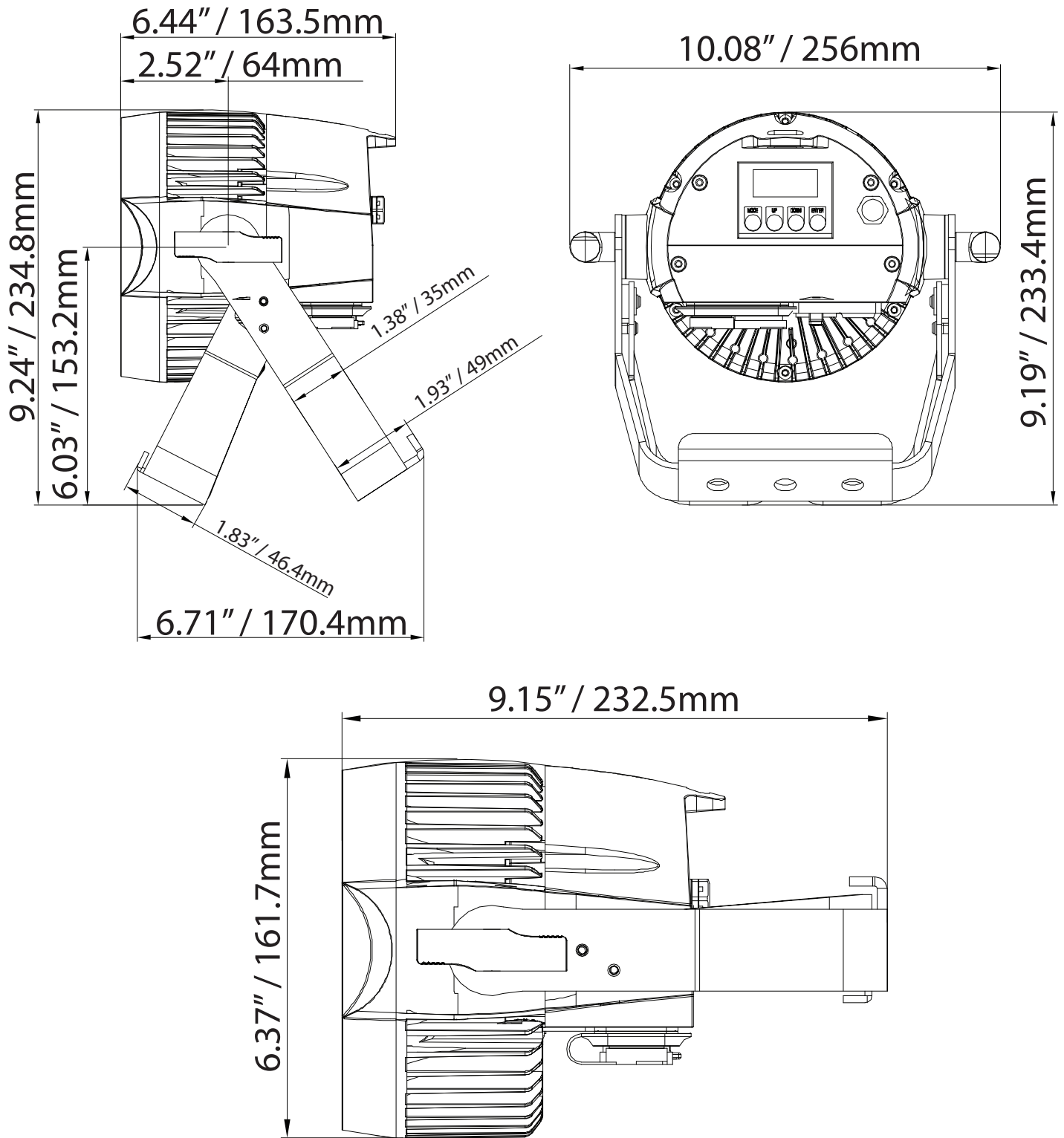

MULTIPLE UNIT POWER LINKING

With this feature you can connect the fixtures to one another using the power input and output sockets. The maximum that can be connected is 20 fixtures @ 120V and 37 fixtures @ 240V. After the maximum connected fixtures you will need to use a new power outlet.

NOTE: USE CAUTION WHEN POWER LINKING OTHER FIXTURES TO THE 7P HEX IP AS THE POWER CONSUMPTION OF OTHER LIGHTING FIXTURES WILL VARY!

TROUBLE SHOOTING

Unit not responding to DMX:

1. Check that the DMX cables are connected properly and are wired correctly (pin 3 is “hot”; on some other DMX devices pin 2 may be ‘hot’). Also, check that all cables are connected to the right connectors; it does matter which way the inputs and outputs are connected.

CLEANING

Due to fog residue, smoke, and dust cleaning the internal and external optical lenses must be carried out periodically to optimize light output.

1. Use normal glass cleaner and a soft cloth to wipe down the outside casing.
 2. Clean the external optics with glass cleaner and a soft cloth every 20 days.
 3. Always be sure to dry all parts completely before plugging the unit back in.
- Cleaning frequency depends on the environment in which the fixture operates (i.e. smoke, fog residue, dust, dew).

LIMITED WARRANTY (USA ONLY)

MANUFACTURER'S LIMITED WARRANTY

- A. ADJ Products, LLC hereby warrants, to the original purchaser, ADJ Products, LLC products to be free of manufacturing defects in material and workmanship for a prescribed period from the date of purchase (see specific warranty period on reverse). This warranty shall be valid only if the product is purchased within the United States of America, including possessions and territories. It is the owner's responsibility to establish the date and place of purchase by acceptable evidence, at the time service is sought.
- B. For warranty service you must obtain a Return Authorization number (RA#) before sending back the product—please contact ADJ Products, LLC Service Department at 800-322-6337. Send the product only to the ADJ Products, LLC factory. All shipping charges must be pre-paid. If the requested repairs or service (including parts replacement) are within the terms of this warranty, ADJ Products, LLC will pay return shipping charges only to a designated point within the United States. If the entire instrument is sent, it must be shipped in its original package. No accessories should be shipped with the product. If any accessories are shipped with the product, ADJ Products, LLC shall have no liability whatsoever for loss of or damage to any such accessories, nor for the safe return thereof.
- C. This warranty is void if the serial number has been altered or removed; if the product is modified in any manner which ADJ Products, LLC concludes, after inspection, affects the reliability of the product; if the product has been repaired or serviced by anyone other than the ADJ Products, LLC factory unless prior written authorization was issued to purchaser by ADJ Products, LLC; if the product is damaged because not properly maintained as set forth in the instruction manual.
- D. This is not a service contract, and this warranty does not include maintenance, cleaning or periodic check up. During the period specified above, ADJ Products, LLC will replace defective parts at its expense with new or refurbished parts, and will absorb all expenses for warranty service and repair labor by reason of defects in material or workmanship. The sole responsibility of ADJ Products, LLC under this warranty shall be limited to the repair of the product, or replacement thereof, including parts, at the sole discretion of ADJ Products, LLC. All products covered by this warranty were manufactured after August 15, 2012, and bear indentifying marks to that effect.
- E. ADJ Products, LLC reserves the right to make changes in design and/or improvements upon its products without any obligation to include these changes in any products theretofore manufactured.

No warranty, whether expressed or implied, is given or made with respect to any accessory supplied with products described above. Except to the extent prohibited by applicable law, all implied warranties made by ADJ Products, LLC in connection with this product, including warranties of merchantability or fitness, are limited in duration to the warranty period set forth above. And no warranties, whether expressed or implied, including warranties of merchantability or fitness, shall apply to this product after said period has expired. The consumer's and/or Dealer's sole remedy shall be such repair or replacement as is expressly provided above; and under no circumstances shall ADJ Products, LLC be liable for any loss or damage, direct or consequential, arising out of the use of, or inability to use, this product.

This warranty is the only written warranty applicable to ADJ Products, LLC Products and supersedes all prior warranties and written descriptions of warranty terms and conditions heretofore published.

MANUFACTURER'S LIMITED WARRANTY PERIODS:

- **Non L.E.D. Lighting Products = 1-year (365 days) Limited Warranty** (Such as: Special Effect Lighting, Intelligent Lighting, UV lighting, Strobes, Fog Machines, Bubble Machines, Mirror Balls, Par Cans, Trussing, Lighting Stands etc. excluding LED and lamps)
- **Laser Products = 1 Year (365 Days) Limited Warranty** (excluding laser diodes which have a 6 month limited warranty)
- **L.E.D. Products = 2-year (730 days) Limited Warranty** (excluding batteries which have a 180 day limited warranty).
Note: 2 Year Warranty only applies to purchases within the United States.
- **StarTec Series = 1 Year Limited Warranty** (excluding batteries which have a 180 day limited warranty).
- **ADJ DMX Controllers = 2 Year (730 Days) Limited Warranty**

TECHNICAL SPECIFICATIONS

Optical:

- Light Source: 7 x 12-Watt RGBAW + UV LEDs (Red, Green, Blue, Amber, White & UV LED) - Rated at approximately 50,000 hrs.)
- Beam angle: 25-degree

Features:

- 4 Operational modes: Static Color Mode, RGBAW & UV Dimmer Mode, Program Mode and DMX Controlled
- 63 built-in Color Macros
- Flicker Free operation (No flickering on camera)
- 5 selectable Dim Curves (Standard, Stage, TV, Architectural & Theatre)
- LED pulse and strobe effect
- Electronic Dimming: 0 - 100%
- Supports RDM (Remote Device Management)
- Scissor Yoke & safety eye

Connections:

- IP65 PowerLock AC In/Out connections
- IP65 Data linkable via 5-pin XLR cables
- Daisy chain: 16 units (120V); 34 units (220V)

Control:

- 4-button, DMX digital display on rear panel
- 4 DMX Modes: 6, 7, 8, & 13-channel

Dimensions / Weight:

- Dimensions (LxWxH): 10" x 6.5" x 9.25" / 256x161.7x232.5mm
- Weight: 7.5 lbs. / 3.3 kg.

Certifications:

- IP Rating: IP65 Outdoor Rated
- cETLus (Control # 4010765)

Included in Box:

- IP65 PowerLocking cable

Please Note: Specifications and improvements in the design of this unit and this manual are subject to change.